

Features

- Output Current in Excess of 0.5 Ampere
- Internal Thermal Overload Protection
- Internal Short-circuit Current Limiting
- High Power Dissipation Capability
- Moisture Sensitivity Level 1
- Halogen Free. "Green" Device (Note 1)
- Epoxy Meets UL 94 V-0 Flammability Rating
- Lead Free Finish/RoHS Compliant ("P" Suffix designates RoHS Compliant. See ordering information)

Maximum Ratings

Parameter	Symbol	Value	Unit
Input Voltage	V_I	10.5~25	V
Storage Temperature Range	T_{STG}	-65~150	°C

Note:

1. Halogen free "Green" products are defined as those which contain <900ppm bromine, <900ppm chlorine (<1500ppm total Br + Cl) and <1000ppm antimony compounds.

Three-Terminal Positive Voltage Regulators

DPAK(TO-252)

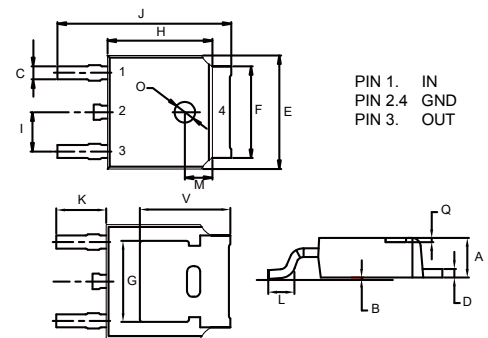

DIM	INCHES		MM		NOTE
	MIN	MAX	MIN	MAX	
A	0.087	0.094	2.20	2.40	
B	0.000	0.005	0.00	0.13	
C	0.026	0.034	0.66	0.86	
D	0.018	0.023	0.46	0.58	
E	0.256	0.264	6.50	6.70	
F	0.201	0.215	5.10	5.46	
G	0.190		4.83		TYP.
H	0.236	0.244	6.00	6.20	
I	0.086	0.094	2.18	2.39	
J	0.386	0.409	9.80	10.40	
K	0.114		2.90		TYP.
L	0.055	0.067	1.40	1.70	
M	0.063		1.60		TYP.
O	0.043	0.051	1.10	1.30	
Q	0.000	0.012	0.00	0.30	
V	0.211		5.35		TYP.

Electrical Characteristics

 ($V_i=10V$, $I_o=350mA$, $0^\circ C < T_j < 125^\circ C$, $C_i=0.33\mu F$, $C_o=0.1\mu F$, Unless Otherwise Specified)

Parameter	Symbol	Test Conditions	Min	Typ	Max	Unit
Output Voltage	V_o	$T_j=25^\circ C$	7.7	8.0	8.3	V
		$10.5V \leq V_i \leq 23V, 5mA \leq I_o \leq 350mA$	7.6	8.0	8.4	V
Load Regulation	ΔV_o	$5mA \leq I_o \leq 500mA, T_j=25^\circ C$	-	-	160	mV
		$5mA \leq I_o \leq 200mA, T_j=25^\circ C$	-	-	80	mV
Line Regulation	ΔV_o	$11.0V \leq V_i \leq 25V, I_o=0.2A$	-	-	100	mV
		$10.5V \leq V_i \leq 25V, I_o=0.2A$	-	-	50	mV
Quiescent Current	I_q	$T_j=25^\circ C$	-	-	6.0	mA
Quiescent Current Change	ΔI_q	$10.5V \leq V_i \leq 25V, I_o=200mA,$ $5mA \leq I_o \leq 350mA$	-	-	0.8	mA
			-	-	0.5	mA
Output Noise Voltage	V_N	$10Hz \leq f \leq 100Hz$	-	52	-	μV
Dropout Voltage	V_d	$T_j=25^\circ C$	-	2.0	-	V

Typcial Application

