

Features

- Maximum Output Current is 1.0A
- Range of Operation Input Voltage: Max 30V
- Line Regulation: 0.03%/V (typ.)
- Standby Current: 2mA (typ.)
- Load Regulation: 0.2%/A (typ.)
- Environment Temperature: -40°C~ 85°C
- Moisture Sensitivity Level 3
- Epoxy Meets UL 94 V-0 Flammability Rating
- Halogen Free. "Green" Device (Note 1)
- Lead Free Finish/RoHS Compliant ("P" Suffix designates RoHS Compliant. See ordering information)

Applications

- Power Management for Computer Mother Board, Graphic Card
- CD Monitor and LCD TV
- DVD Decode Board
- ADSL Modem
- Post Regulators For Switching Supplies

Description

MCT1117C is a series of low dropout three-terminal regulators with a dropout of 1.3V at 1A load current. MCT1117C features a very low standby current 2mA compared to 5mA of competitor.

Other than a fixed version, $V_{out} = 1.2V, 1.5V, 1.8V, 2.5V, 2.85V, 3.3V,$ and 5V, MCT1117C has an adjustable version, which can provide an output voltage from 1.25 to 12V with only two external resistors.

MCT1117C offers thermal shut down function, to assure the stability of chip and power system. And it uses trimming technique to guarantee output voltage accuracy within 2%. Other output voltage accuracy can be customized on demand, such as 1%.

MCC Part Number	Device Marking ⁽²⁾
MCT1117C-1.2	1117 1.2 YYWW
MCT1117C-1.5	1117 1.5 YYWW
MCT1117C-1.8	1117 1.8 YYWW
MCT1117C-2.5	1117 2.5 YYWW
MCT1117C-2.85	1117 2.8 YYWW
MCT1117C-3.3	1117 3.3 YYWW
MCT1117C-5.0	1117 5.0 YYWW
MCT1117C-ADJ	1117 ADJ YYWW

Note: 1. Halogen free "Green" products are defined as those which contain <900ppm bromine, <900ppm chlorine (<1500ppm total Br + Cl) and <1000ppm antimony compounds.
2. YYWW: Date Code.

Low Dropout Linear Regulator

SOT-223

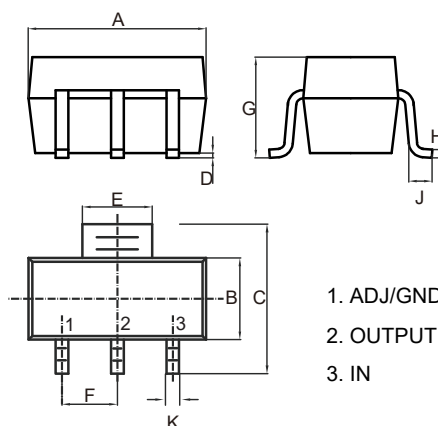

DIMENSIONS

DIM	INCHES		MM		NOTE
	MIN	MAX	MIN	MAX	
A	0.248	0.264	6.30	6.70	
B	0.130	0.146	3.30	3.70	
C	0.264	0.287	6.70	7.30	
D	0.001	0.004	0.02	0.10	
E	0.114	0.122	2.90	3.10	
F	0.091		2.30		TYP.
G	---	0.071	---	1.80	
H	0.009	0.014	0.23	0.35	
J	0.030	---	0.75	---	
K	0.026	0.033	0.66	0.84	

Suggested Solder Pad Layout

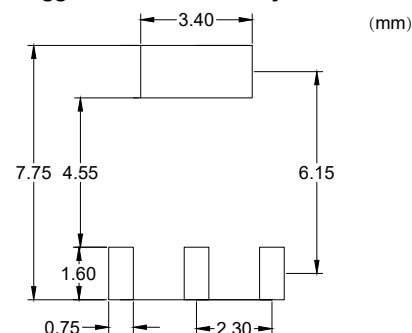

Functional Block Diagram

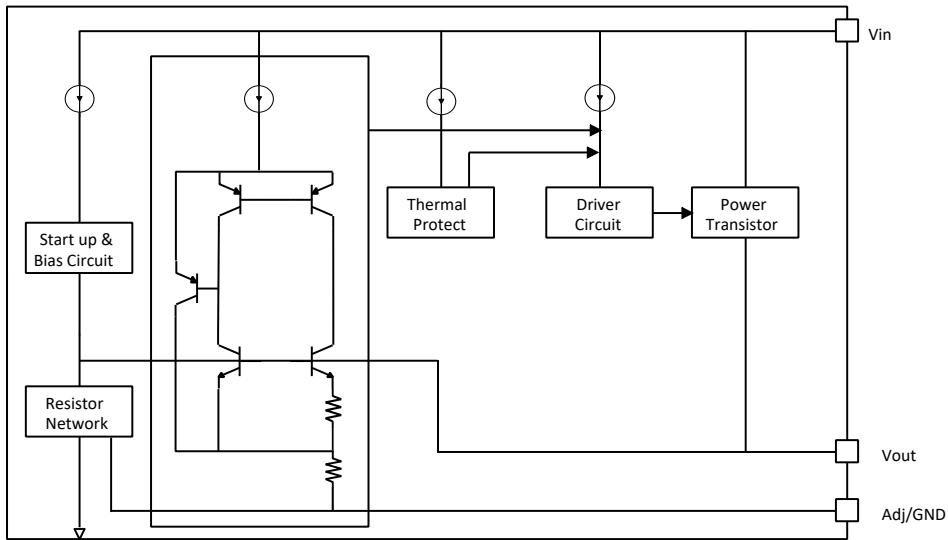

Typical Application Circuit

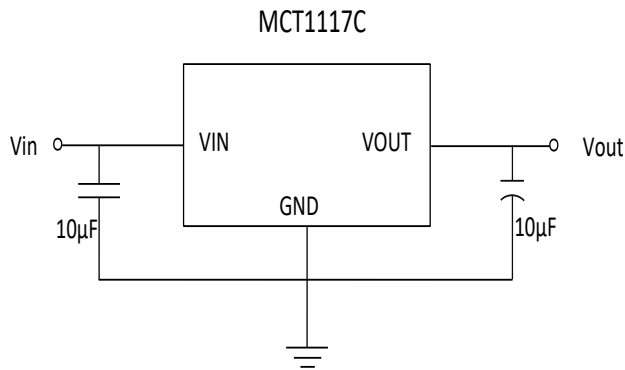

Application circuit of MCT1117C fixed version

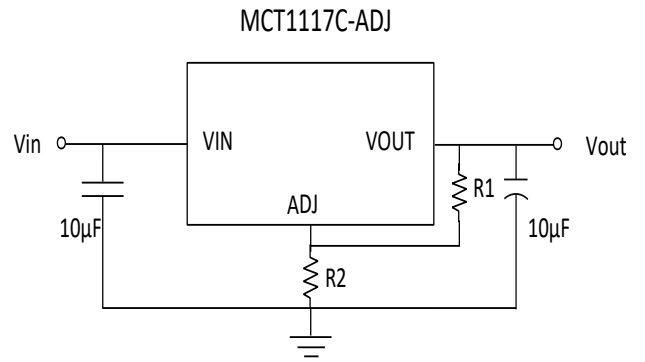

Application circuit of MCT1117C-ADJ

Absolute Maximum Ratings

- Max Input Voltage: 30V
- Max Operating Junction Temperature: 150°C
- Ambient Temperature Range: -40~+85°C
- Storage Temperature Range: -40~+150°C
- Lead Temperature & Time: 260°C, 10s

Caution: Exceed these limits to damage to the device. Exposure to absolute maximum rating conditions may affect device reliability.

Recommended Work Conditions

- Recommended Maximum Input Voltage: 18V
- Recommended Operating Junction Temperature: -20~+125°C

Package Thermal Resistance

- SOT-223 θ_{JC} : 20 °C/W
- SOT-223 θ_{JA} : 60 °C/W

Power Dissipation

- SOT-223 : 1.2W

Electrical Characteristics ($T_A=25^\circ\text{C}$, unless otherwise noted.)

Parameter	Symbol	Item	Test Conditions	Min	Typ	Max	Unit
Reference Voltage	Vref	ADJ	$10\text{mA} \leq I_{out} \leq 1\text{A}$, $V_{in}=3.25\text{V}$	1.225	1.25	1.275	V
Output Voltage	Vout	1.2V	$0 \leq I_{out} \leq 1\text{A}$, $V_{in}=3.2\text{V}$	1.176	1.2	1.224	V
		1.5V	$0 \leq I_{out} \leq 1\text{A}$, $V_{in}=3.5\text{V}$	1.47	1.5	1.53	
		1.8V	$0 \leq I_{out} \leq 1\text{A}$, $V_{in}=3.8\text{V}$	1.764	1.8	1.836	
		2.5V	$0 \leq I_{out} \leq 1\text{A}$, $V_{in}=4.5\text{V}$	2.45	2.5	2.55	
		2.85V	$0 \leq I_{out} \leq 1\text{A}$, $V_{in}=4.85\text{V}$	2.793	2.85	2.907	
		3.3V	$0 \leq I_{out} \leq 1\text{A}$, $V_{in}=5.3\text{V}$	3.234	3.3	3.366	
		5.0V	$0 \leq I_{out} \leq 1\text{A}$, $V_{in}=7\text{V}$	4.9	5	5.1	
Line Regulation	ΔV_{out}	ADJ	$I_{out}=10\text{mA}$, $2.75\text{V} \leq V_{in} \leq 12\text{V}$		0.03	0.2	%V
		1.2V	$I_{out}=10\text{mA}$, $2.7\text{V} \leq V_{in} \leq 10\text{V}$		0.03	0.2	
		1.5V	$I_{out}=10\text{mA}$, $3\text{V} \leq V_{in} \leq 10\text{V}$		0.03	0.2	
		1.8V	$I_{out}=10\text{mA}$, $3.3\text{V} \leq V_{in} \leq 12\text{V}$		0.03	0.2	
		2.5V	$I_{out}=10\text{mA}$, $4.0\text{V} \leq V_{in} \leq 12\text{V}$		0.03	0.2	
		2.85V	$I_{out}=10\text{mA}$, $4.35\text{V} \leq V_{in} \leq 12\text{V}$		0.03	0.2	
		3.3V	$I_{out}=10\text{mA}$, $4.8\text{V} \leq V_{in} \leq 12\text{V}$		0.03	0.2	
		5.0V	$I_{out}=10\text{mA}$, $6.5\text{V} \leq V_{in} \leq 12\text{V}$		0.03	0.2	

Electrical Characteristics ($T_A=25^{\circ}\text{C}$, unless otherwise noted.)

Parameter	Symbol	Item	Test Conditions	Min	Typ	Max	Unit	
Load Regulation	ΔV_{out}	ADJ	$V_{in} = 2.75\text{V}, 10\text{mA} \leq I_{out} \leq 1\text{A}$		2	8	mV	
		1.2V	$V_{in} = 2.7\text{V}, 10\text{mA} \leq I_{out} \leq 1\text{A}$		2	8		
		1.5V	$V_{in} = 3.0\text{V}, 10\text{mA} \leq I_{out} \leq 1\text{A}$		2	8		
		1.8V	$V_{in} = 3.3\text{V}, 10\text{mA} \leq I_{out} \leq 1\text{A}$		3	12		
		2.5V	$V_{in} = 4.0\text{V}, 10\text{mA} \leq I_{out} \leq 1\text{A}$		4	16		
		2.85V	$V_{in} = 4.35\text{V}, 10\text{mA} \leq I_{out} \leq 1\text{A}$		5	20		
		3.3V	$V_{in} = 4.8\text{V}, 10\text{mA} \leq I_{out} \leq 1\text{A}$		6	24		
		5.0V	$V_{in} = 6.5\text{V}, 10\text{mA} \leq I_{out} \leq 1\text{A}$		9	36		
Dropout Voltage	V_{drop}		$I_{out} = 100\text{mA}$		1.15	1.3	V	
			$I_{out} = 1\text{A}$		1.3	1.4		
Minimum Load Current	I_{min}	ADJ			2	10	mA	
Quiescent Current	I_q	1.2V	$V_{in} = 10\text{V}$		2	5	mA	
		1.5V	$V_{in} = 10\text{V}$		2	5		
		1.8V	$V_{in} = 12\text{V}$		2	5		
		2.5V	$V_{in} = 12\text{V}$		2	5		
		2.85V	$V_{in} = 12\text{V}$		2	5		
		3.3V	$V_{in} = 12\text{V}$		2	5		
		5.0V	$V_{in} = 12\text{V}$		2	5		
Adjust Pin Current	I_{adj}	ADJ	$V_{in} = 5\text{V}, 10\text{mA} \leq I_{out} \leq 1\text{A}$		55	120	μA	
I_{adj} Change	I_{change}	ADJ	$V_{in} = 5\text{V}, 10\text{mA} \leq I_{out} \leq 1\text{A}$		0.2	10	μA	
Temperature Coefficient	$\Delta V/\Delta T$		$V_{in} = 4.5\text{V}, I_{out} = 10\text{mA}, V_{OUT} = 3.3\text{V}$ $20^{\circ}\text{C} \leq T_a \leq 120^{\circ}\text{C}$		± 100		ppm	
Maximum Output Current	$I_{out(max)}$				1.0	1.2	A	
Power Supply Rejection Ratio	PSRR		Ripple 1.0 V_{p-p} $V_{IN} = V_{OUT} + 2\text{V},$ $I_{OUT} = 100\text{mA}$	$f = 120\text{Hz}$		60		dB
				$f = 1\text{KHz}$		62		dB
RMS Output Noise	V_{NOISE}		$10\text{Hz} \leq f \leq 100\text{kHz}, \text{No Load}$		0.005		%	
Thermal Shutdown Temperature	T_{OTSD}				220		$^{\circ}\text{C}$	
Thermal Shutdown Hysteresis	T_{HYOTSD}				20		$^{\circ}\text{C}$	

* All test are conducted under ambient temperature 25°C and within a short period of time 20ms.

* Load current smaller than minimum load current of MCT1117C-ADJ will lead to unstable or oscillation output.

Curve Characteristics

Fig.1 - MCT1117C-ADJ Line regulation

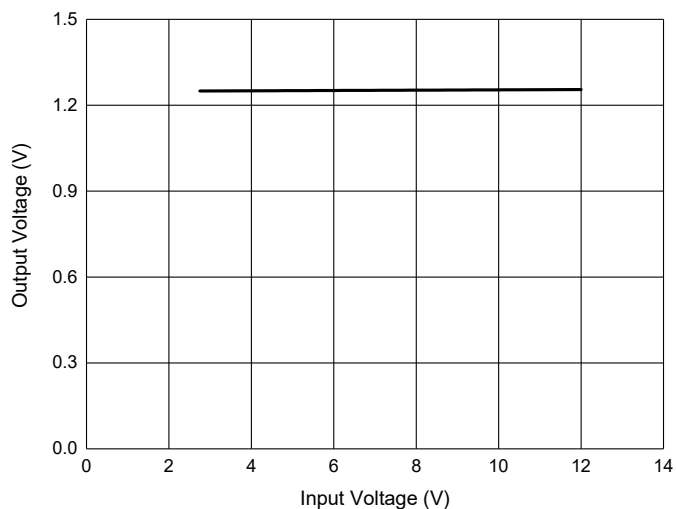

Fig.2 - MCT1117C-ADJ Load Regulation

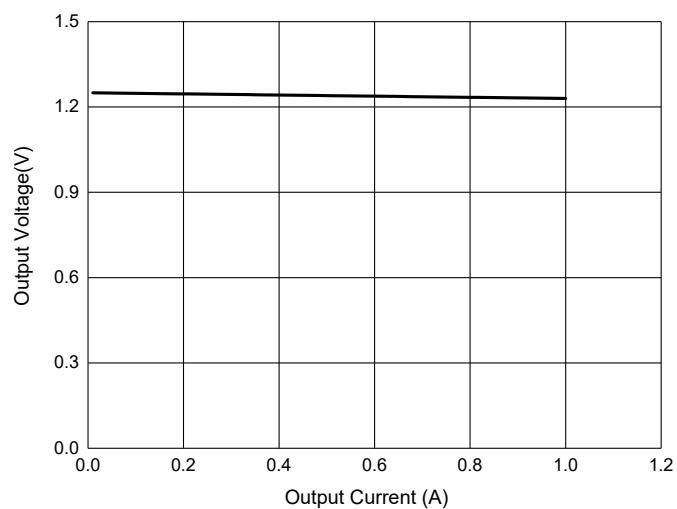

Fig.3 - MCT1117C-ADJ Dropout Voltage

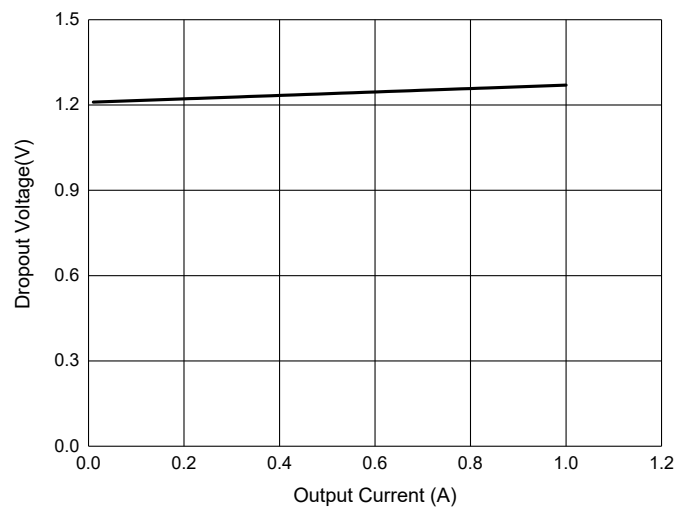

Fig. 4 - MCT1117C-ADJ Thermal Performance with OTP

