

# MCZ5303SG

## Starter IC

### Feature

- HV Startup
- Optimised burst mode control
- VW(max)=35V
- Internal regulator : 18.5V
- Input main line sensing
- Thermal shutdown
- Pb free
- RoHS:Yes

### Outline

House Name: SOP16



1 絶対最大定格(at Tc=25°C)

1 Absolute Maximum Ratings (at Tc=25°C)

1-1 熱規格

1-1 Thermal Ratings

項目 Item	記号 Symbol	規格値 Ratings	単位 Unit
保存温度 Storage temperature	Tstg	-55~150	°C
接合部温度 Junction temperature	Tj	-20~150	°C
許容損失 Total power dissipation	Pt	0.85	W
熱抵抗 Thermal resistance	$\theta_{ja}$	147(※1)	°C/W

※1 4-layerBoard

ガラスエポキシ基板: 114.3mm×76.2mm, 厚さ:1.6mm, 内面銅箔サイズ: 74.2mm×74.2mm, 厚さ35um

Glass-Epoxy Board: 114.3mm×76.2mm, Thickness: 1.6mm, Inside copper foil: 74.2mm×74.2mm, Thickness: 35um

1-2 電気的規格

1-2 Electrical Ratings

項目 Item	記号 Symbol	規格値 Ratings	単位 Unit
Vin端子 印加電圧 Vin voltage	Vin	-0.3~500	V
VW端子 印加電圧 VW voltage	VW	-0.3~35	V
VW端子 印加電流 VW current	I_VW	-1~200	mA
Vcc端子 印加電圧 Vcc voltage	Vcc	-0.3~24	V
LSin端子 印加電圧 LSin voltage	V_LSin	-0.3~10	V
LSout端子 印加電圧 LSout voltage	V_LSout	-0.3~4.2	V
COMPIn端子 印加電圧 COMPIn voltage	V_COMPIn	-0.3~4.2	V
COMPout端子 印加電圧 COMPout voltage	V_COMPout	-0.3~5	V
STBY端子 印加電圧 STBY voltage	V_STBY	-0.3~4.2	V
ASin端子 印加電圧 ASin voltage	V_ASin	-0.3~4.2	V
KAS端子 印加電圧 KAS voltage	V_KAS	-0.3~5	V
SSC端子 印加電圧 SSC voltage	V_SSC	-0.3~5	V
KSST端子 印加電圧 KSST voltage	V_KSST	-0.3~5	V

注意 : 本仕様書に記載されていない項目、使用条件、論理の組み合わせでの使用は保証していません。

記載されている以外の条件で使用する場合は必ず事前に当社担当営業部門までご相談下さい。

記載内容は改良などのためにお断り無しに変更することがあります。

Notes : Using with parameters, condition of use and logic controls that are not specified in the specifications are not assured.

When used with the conditions that are not specified, please consult us in advance.

The contents described herein are subject to change without notice.

## 2 推奨動作条件

### 2 Recommended Operation Conditions

項目 Item	記号 Symbol	推奨値 Recommended value			単位 Unit
		min	typ	max	
動作温度 Operating temperature	Top	-20	---	125	°C
Vin端子印加電圧 Vin applied voltage	Vin	95	---	450	V
VW端子印加電圧 VW applied voltage	VW	---	---	30	V
VCC端子印加電圧 VCC applied voltage	VCC	11	---	22	V
ASin端子印加電圧 ASin applied voltage	ASin	0	---	3.8	V
STBY端子印加電圧 STBY applied voltage	STBY	0	---	3.8	V

注意 : 上記の規格範囲内においても、製品寿命に関しましてはお客様の使用環境により異なりますので、長寿命を期待される製品にご使用される場合には Tj=100°C以下でご使用頂く事を推奨致します。

Notes : The product life depends on the condition of use even within the above operating conditions.  
Using at Tj = 100°C or less is recommended for the equipment where a long life is expected.

3-1 電氣的・熱的特性 (at Ta=25°C)

3-1 Electrical/Thermal Characteristics (at Ta=25°C)

項目 Item	記号 Symbol	条件 Condition	規格値 Ratings			単位 Unit
			min	typ	max	

ドレインキック機能(Drainkick section)

Vcc充電電流(起動時) Vcc cuurent (Starting)	Id_startup1	Vin=100V, Vcc=1V	2.2	2.7	3.2	mA
	Id_startup2	Vin=100V, Vcc=15V	11.5	14.5	17.5	mA
Vin消費電流(ドレインキックOFF) Vin current(Drainkick turn off)	Id_OFF	Vin=100V, VW=20V	---	12.0	20.0	uA
VW電圧(ドレインキック再起動) VW voltage(Drainkick restart)	VVW_DKON	Vin=100V,	7.0	7.5	8.0	V
VW電圧(ドレインキックOFF) VW voltage(Drainkick turn off)	VVW_DKOFF	Vin=100V,	Vcc+0.5	Vcc+1	Vcc+1.5	V

Dropper機能(Dropper section)

Vcc電圧 Vcc voltage	V_Vcc_H	VW=20V	18.0	18.5	19.0	V
VW-Vcc電圧降下 VW-Vcc voltage drop	V_drp_del	VW=15V	---	0.1	0.5	V
Vcc-VW間耐圧 Vcc-VW breakdown voltage	V_Vcc_Di	VW=0V	16.0	---	---	V
VW端子電流 VW cuurent	I_VW	VW=15V	---	290	---	uA

Vcc不足電圧保護回路(Vcc under voltage protection)

起動回路ON電圧 Start-Up circuit on voltege	Vcc(start)	VW=COMPIn=0V	9.0	10.0	11.0	V
起動回路OFF電圧 Start-Up circuit cut off voltage	Vcc(stop)	VW=COMPIn=0V	6.3	7.0	7.7	V
Vcc端子電流(起動前) Vcc current (before start-up)	I_VCC_stby	Vcc=8V	170	210	250	uA
Vcc端子電流(動作時) Vcc current(operating)	I_VCC_stt	Vcc=15V ,COMPIn=5V	208	260	312	uA

3-2 電氣的・熱的特性 (at Ta=25°C)

3-2 Electrical/Thermal Characteristics (at Ta=25°C)

項目 Item	記号 Symbol	条件 Condition	規格値 Ratings			単位 Unit
			min	typ	max	

MainMOSFET

ドレイン遮断電流 Drain breaking current	IDSS_Main	VW=20V, COMPin=5V	---	---	3	uA
ON抵抗 On-state resistance	Ron_Main	Vcc=15V, COMPin=0V, I_KVc1=30mA	---	20	---	Ω

バーストモード(BurstMode)

COMPin上限閾値電圧 COMPin upper threshold voltage	V_COMP_H	VW=15V,	1.02	1.06	1.1	V
COMPin下限閾値電圧 COMPin lower threshold voltage	V_COMP_L	VW=15V,	0.92	0.96	1.0	V
COMPout放電電流 COMPout discharge current	I_COMPout	COMPout=5V COMPin=0V	3.5	4.5	5.5	mA
KSST端子放電電流 KSST discharge current	I_SST	KSST=5V,COMPin=5V	14	16	18	mA

入力電圧監視機能(Detected input voltage section)

KVC1出力開始LS電圧 LS voltage of start KVC1 output	V_LS_stt	Vcc=15V,	1	1.05	1.1	V
KVC1出力停止LS電圧 LS voltage of start KVC1 output	V_LS_stp	Vcc=15V,	0.7	0.75	0.8	V
LSout放電電流 LSout discharge current	I_LSOin	LSout=5V, LSin=0V	14	16	18	mA
LSout充電電流 LSout charge current	I_LSOout	LSout=0V, LSin=2V	-3	-2	-1	mA

AS機能(AS section)

KAS出力短絡時AS電圧 AS voltage to KAS output short-circuit	V_AS_sht	Vcc=15V,STBY=0V	2.7	3.0	---	V
KAS出力開放時AS電圧 AS voltage to KAS open	V_AS_opn	Vcc=15V,STBY=0V	---	1.20	1.32	V
KAS放電電流 KAS discharge current	I_ASO	KAS=5V,ASin=5V	3.5	4.5	5.5	mA

3-3 電氣的・熱的特性 (at Ta=25°C)

3-3 Electrical/Thermal Characteristics (at Ta=25°C)

項目 Item	記号 Symbol	条件 Condition	規格値 Ratings			単位 Unit
			min	typ	max	

モード切替機能(Changing mode section)

バーストモード開始電圧 Burst mode start voltage	V_stby_bur	V <sub>cc</sub> =15V	2.7	3.0	---	V
通常モード開始電圧 Normal mode start voltage	V_stby_nor	V <sub>cc</sub> =15V	---	1.20	1.32	V

SSC機能(SSC section)

SSC放電電流 SSC discharge current	I <sub>SSC</sub>	V <sub>cc</sub> =15V	14.0	16.0	18.0	mA
----------------------------------	------------------	----------------------	------	------	------	----

過熱保護回路(Thermal shutdown section)

動作停止温度※1 Operating stop temperature	V_TSD_stt	V <sub>CC</sub> =15V	---	150	---	°C
動作復帰温度※1 Operating restart temperature	V_TSD_stp	V <sub>cc</sub> =15V	---	90	---	°C

※1 設計保証

※1 This parameter is not tested during production , by design it is guaranteed.

4.端子配置 & 端子機能

4.Pin assnment & Pin function

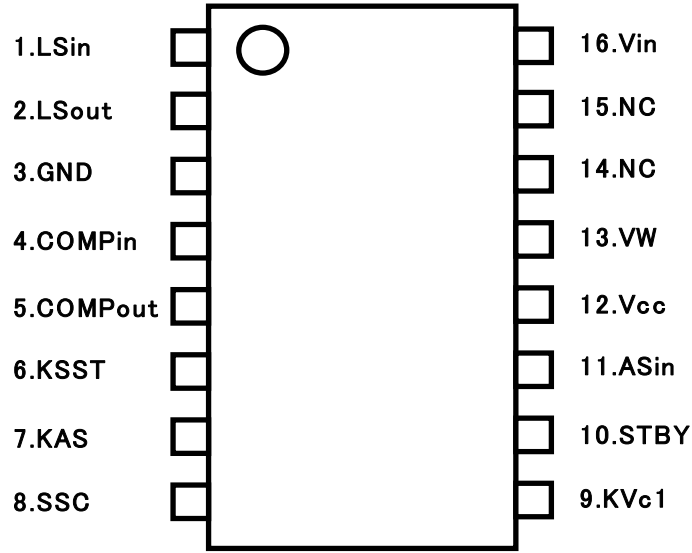

package : SOP16

記号 symbol	端子番号 number	端子名 terminal name
LSin	1	AC入力監視コンパレータ入力端子 Input terminal for AC input detection comp.
LSout	2	AC入力監視コンパレータ出力端子 Output terminal for AC input detection comp.
GND	3	GND端子 GND terminal.
COMPIn	4	バースト制御コンパレータ入力端子 Input terminal for burst control comp.
COMPout	5	バースト制御コンパレータ出力端子 Output terminal for burst control comp.
KSST	6	SST放電端子 Terminal for discharging SST
KAS	7	AS切り替え信号出力端子 Output terminal for changing AS signal
SSC	8	ソフトスタート回路切り替え端子 Terminal for changing SS condenser capacity
KVc1	9	Vc1供給端子 Terminal for supplying Vc1
STBY	10	スタンバイモード切り替え端子 Terminal for changing Stand-by mode
ASin	11	AS切り替え信号入力端子 Input terminal for changing AS signal
Vcc	12	電源端子 Terminal for a power supply
VW	13	制御巻き線電圧入力端子 Input terminal from supply inductor winding
NC	14,15	未使用端子 No connection terminal
Vin	16	起動回路入力端子 Start-up circuit input terminal

5.ブロック図  
5.Block diagram

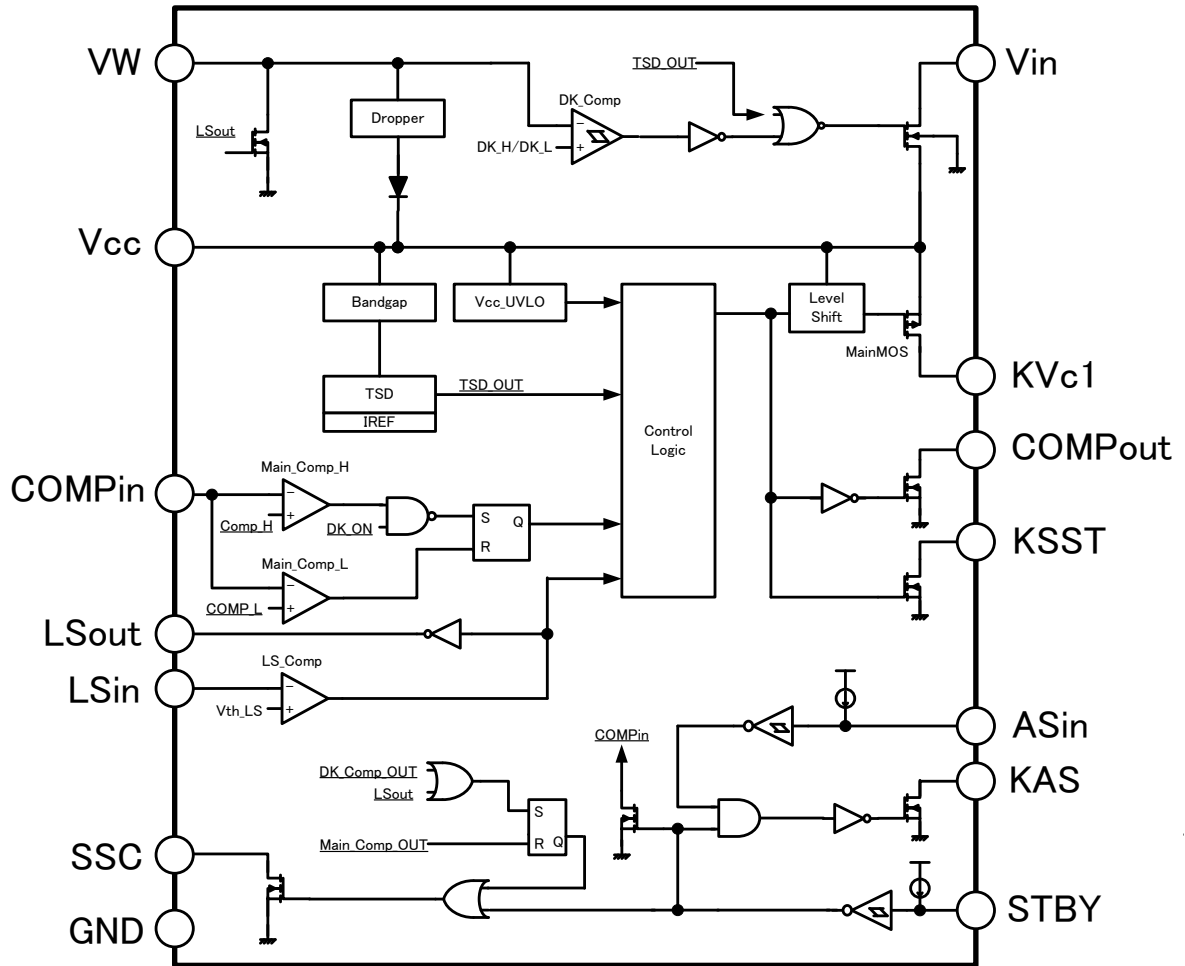



# Package Outline-Dimensions

unit : mm  
scale: 3/1

L5

JEDEC Code	-
JEITA Code	-
House Name	SOP16

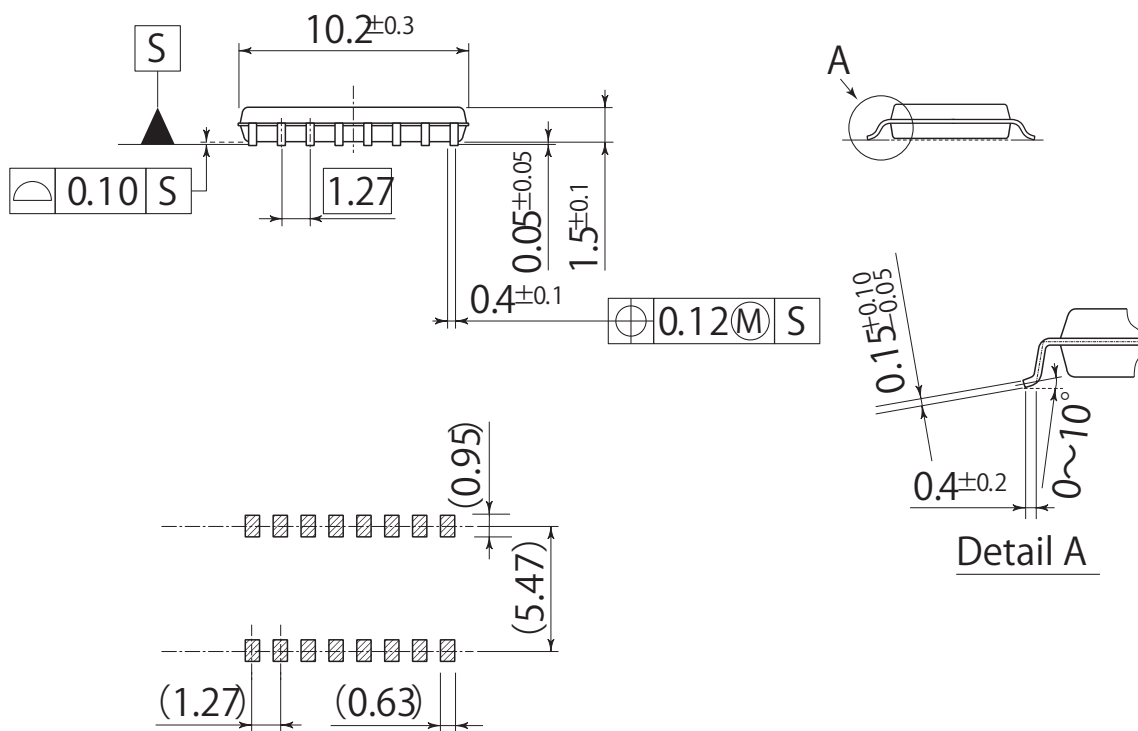
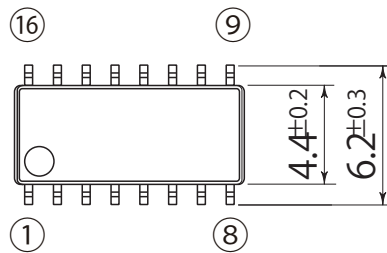

## Referential Soldering Pad

- 量産時には、適正化を図って下さい
- Optimize soldering pad to the board design and soldering condition.

- 本資料の記載内容は、改良のため予告なく変更することがあります
- ご使用にあたりましては、別途仕様書を必ずご請求下さい
- The content specified herein is subject to change for improvement without notice.
- If you wish to use any such products, please be sure to refer to the specifications.

U182(2019.02)