



MD2001FX

High voltage NPN power transistor for standard definition CRT display

Features

- State-of-the-art technology:
 - Diffused collector “Enhanced generation”
- Stable performances versus operating temperature variation
- Low base-drive requirements
- Tight h_{FE} range at operating collector current
- Fully insulated power package U.L. compliant

Applications

- Horizontal deflection output for monitor and real flat TV

Description

The MD2001FX is manufactured using Diffused Collector in Planar Technology adopting new and enhanced high voltage structure. The new MD product series show improved silicon efficiency bringing updated performance to the Horizontal Deflection stage.

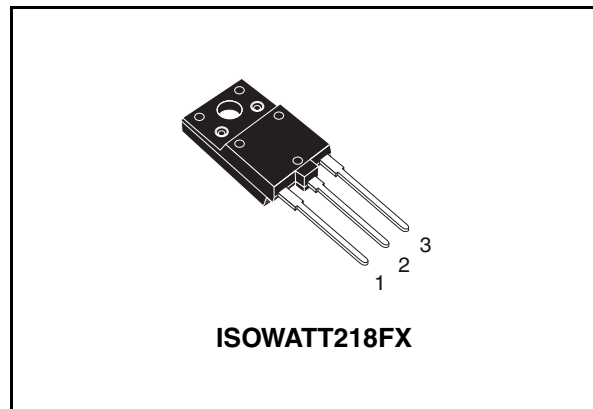

Figure 1. Internal schematic diagram

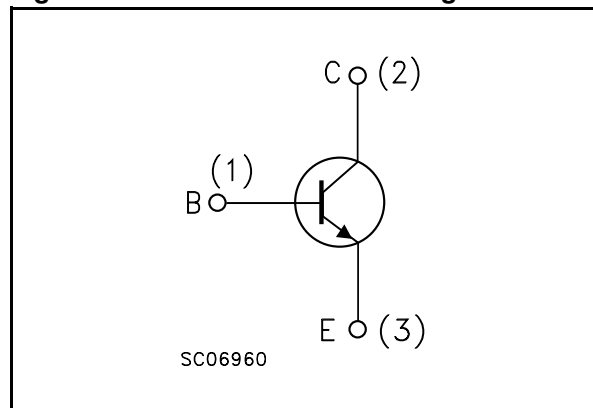

Table 1. Device summary

Order code	Marking	Package	Packaging
MD2001FX	MD2001FX	ISOWATT218FX	Tube

Content

1	Electrical ratings	3
2	Electrical characteristics	4
2.1	Electrical characteristics (curves)	5
2.2	Test circuits	7
3	Package mechanical data	8
4	Revision history	10

1 Electrical ratings

Table 2. Absolute maximum rating

Symbol	Parameter	Value	Unit
V_{CES}	Collector-emitter voltage ($V_{BE} = 0$)	1500	V
V_{CEO}	Collector-emitter voltage ($I_B = 0$)	700	V
V_{EBO}	Collector-base voltage ($I_C = 0$)	9	V
I_C	Collector current	12	A
I_{CM}	Collector peak current ($t_p < 5\text{ms}$)	18	A
I_B	Base current	6	A
P_{TOT}	Total dissipation at $T_C = 25^\circ\text{C}$	58	W
V_{ins}	Insulation withstand voltage (RMS) from all three leads to external heatsink	2500	V
T_{stg}	Storage temperature	-65 to 150	°C
T_J	Max. operating junction temperature	150	

Table 3. Thermal data

Symbol	Parameter	Value	Unit
$R_{thj-case}$	Thermal resistance junction-case	max 2.15	°C/W

2 Electrical characteristics

($T_{\text{case}} = 25^{\circ}\text{C}$ unless otherwise specified)

Table 4. Electrical characteristics

Symbol	Parameter	Test conditions	Min.	Typ.	Max.	Unit
I_{CES}	Collector cut-off current ($V_{\text{BE}} = 0$)	$V_{\text{CE}} = 1500\text{V}$ $V_{\text{CE}} = 1500\text{V}; T_{\text{C}} = 125^{\circ}\text{C}$			0.2 2	mA mA
I_{EBO}	Emitter cut-off current ($I_{\text{C}} = 0$)	$V_{\text{EB}} = 9\text{V}$			1	mA
$V_{\text{CEO(sus)}}^{(1)}$	Collector-emitter sustaining voltage ($I_{\text{C}} = 0$)	$I_{\text{C}} = 100\text{mA}$	700			V
$V_{\text{CE(sat)}}^{(1)}$	Collector-emitter saturation voltage	$I_{\text{C}} = 6\text{A}$ $I_{\text{B}} = 1.5\text{A}$			1.8	V
$V_{\text{BE(sat)}}^{(1)}$	Base-emitter saturation voltage	$I_{\text{C}} = 6\text{A}$ $I_{\text{B}} = 1.5\text{A}$			1.2	V
$h_{\text{FE}}^{(1)}$	DC current gain	$I_{\text{C}} = 6\text{A}$ $V_{\text{CE}} = 1\text{V}$ $I_{\text{C}} = 6\text{A}$ $V_{\text{CE}} = 5\text{V}$	4.5	4.5	7	
t_{s} t_{f}	Inductive load Storage time Fall time	$I_{\text{C}} = 5\text{A}$ $I_{\text{B(on)}} = 0.9\text{A}$ $V_{\text{BE(off)}} = -2.7\text{V}$ $f_{\text{h}} = 64\text{KHz}$ $L_{\text{BB(off)}} = 1.6\mu\text{H}$		2.6 0.2		μs μs

1. Pulsed: Pulse duration = 300 ms, duty cycle 1.5 %

2.1 Electrical characteristics (curves)

Figure 2. Safe operating area

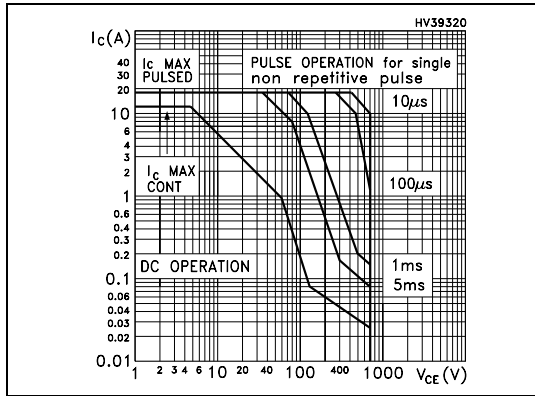

Figure 3. Derating curve

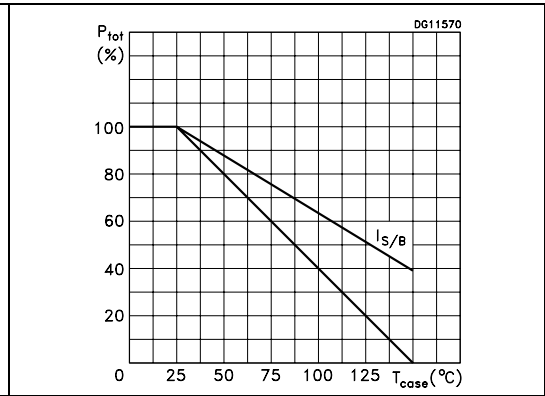

Figure 4. DC current gain

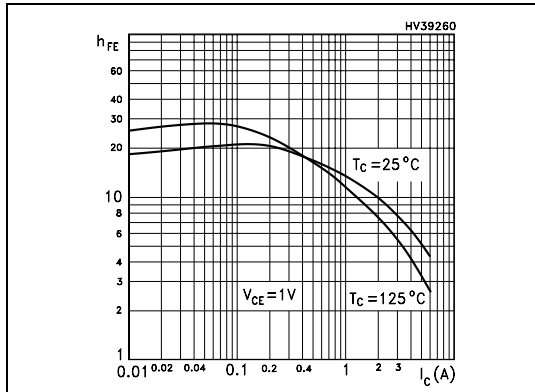

Figure 5. DC current gain

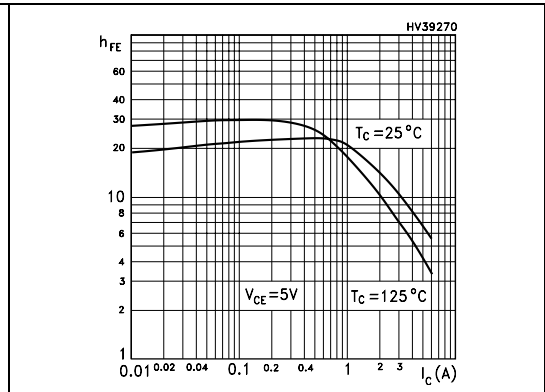

Figure 6. Collector-emitter saturation voltage

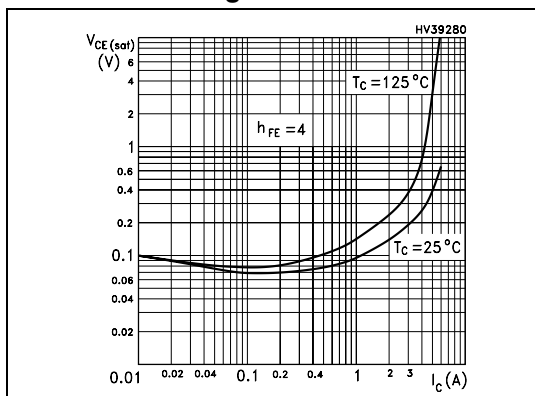

Figure 7. Base-emitter saturation voltage

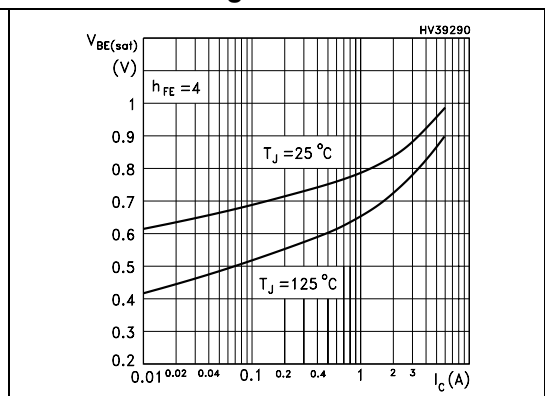
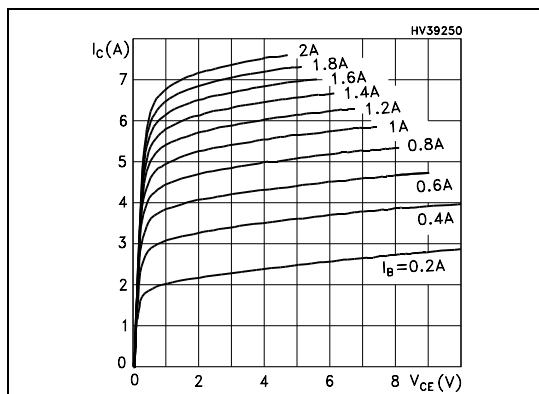

Figure 8. Output characteristics



2.2 Test circuits

Figure 9. Power losses and inductive load switching

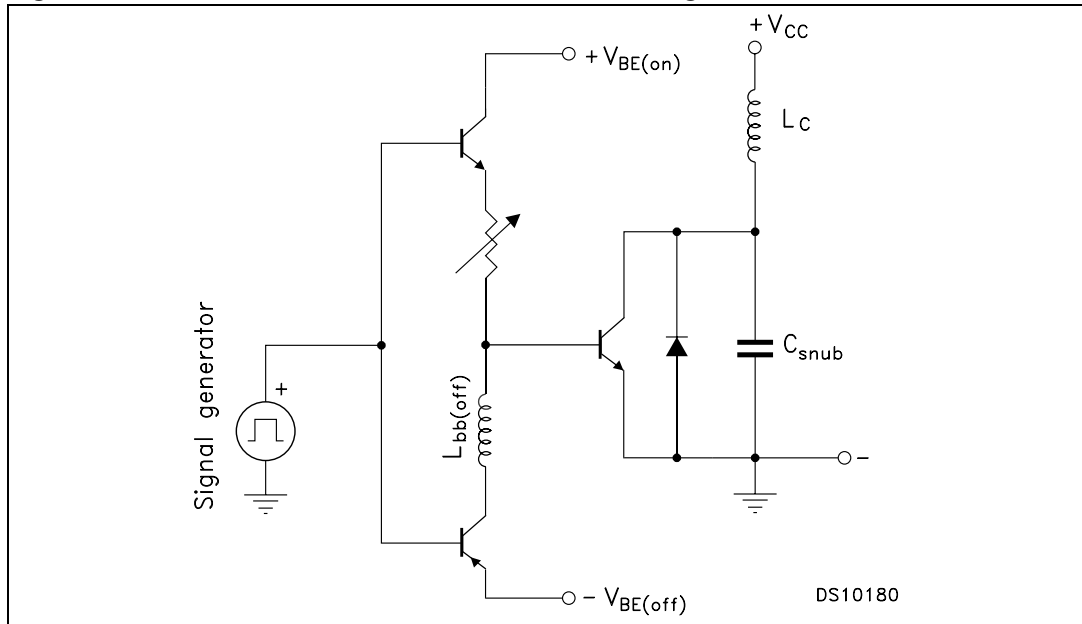
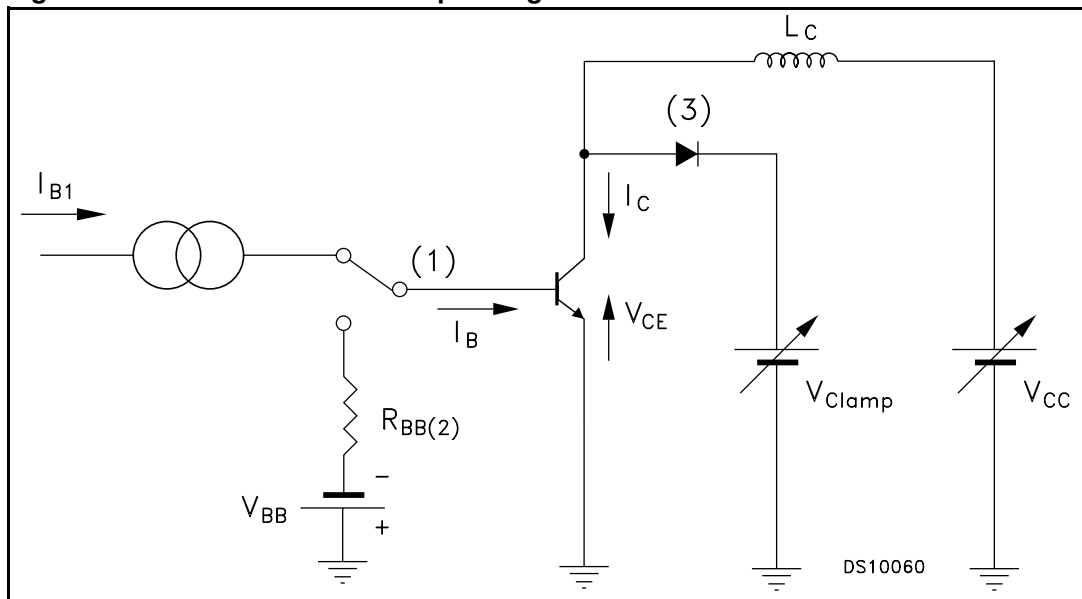

Figure 10. Reverse biased safe operating area



3 Package mechanical data

In order to meet environmental requirements, ST offers these devices in ECOPACK® packages. These packages have a Lead-free second level interconnect. The category of second level interconnect is marked on the package and on the inner box label, in compliance with JEDEC Standard JESD97. The maximum ratings related to soldering conditions are also marked on the inner box label. ECOPACK is an ST trademark. ECOPACK specifications are available at: www.st.com

4 Revision history

Table 5. Document revision history

Date	Revision	Changes
25-May-2007	1	Initial release.
14-Aug-2007	2	Complete document, added all curves (2.1: Electrical characteristics (curves))