



# MD2310FX

High voltage NPN power transistor for standard definition CRT display

## Features

- State-of-the-art technology:
  - diffused collector “enhanced generation”
- Stable performance versus operating temperature variation
- Low base drive requirement
- Tight  $h_{FE}$  range at operating collector current
- Fully insulated power package U.L. compliant

## Application

- Horizontal deflection output for monitor and real flat TV

## Description

The MD2310FX is manufactured using planar technology with diffused collector adopting new and enhanced high voltage structure. The MD product series show improved silicon efficiency bringing updated performance to the horizontal deflection stage.

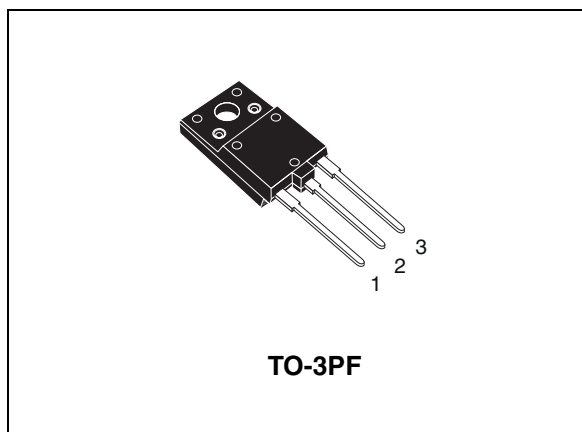

Figure 1. Internal schematic diagram

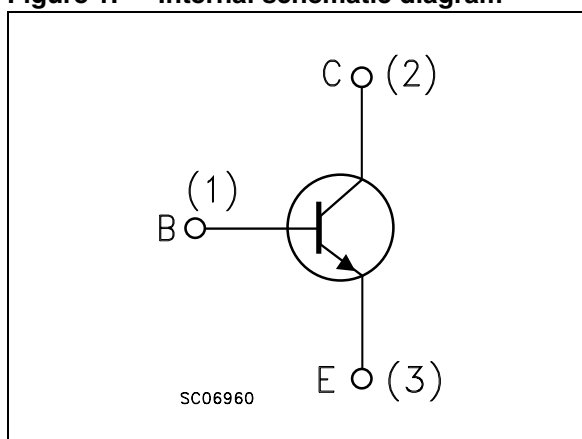

Table 1. Device summary

Order code	Marking	Package	Packing
MD2310FX	MD2310FX	TO-3PF	Tube

# 1 Electrical ratings

**Table 2. Absolute maximum ratings**

Symbol	Parameter	Value	Unit
$V_{CES}$	Collector-emitter voltage ( $V_{BE} = 0$ )	1500	V
$V_{CEO}$	Collector-emitter voltage ( $I_B = 0$ )	700	V
$V_{EBO}$	Emitter-base voltage ( $I_C = 0$ )	9	V
$I_C$	Collector current	14	A
$I_{CM}$	Collector peak current ( $t_P < 5$ ms)	21	A
$I_B$	Base current	7	A
$P_{TOT}$	Total dissipation at $T_c = 25$ °C	62	W
$V_{INS}$	Insulation withstand voltage (RMS) from all three leads to external heatsink	2500	V
$T_{STG}$	Storage temperature	-65 to 150	°C
$T_J$	Max. operating junction temperature	150	

**Table 3. Thermal data**

Symbol	Parameter	Value	Unit
$R_{thJC}$	Thermal resistance junction-case	Max 2	°C/W

## 2 Electrical characteristics

$T_{CASE} = 25\text{ °C}$ ; unless otherwise specified.

**Table 4. Electrical characteristics**

Symbol	Parameter	Test conditions	Min.	Typ.	Max.	Unit
$I_{CES}$	Collector cut-off current ( $V_{BE} = 0$ )	$V_{CE} = 1500\text{ V}$			0.2	mA
		$V_{CE} = 1500\text{ V}$ $T_c = 125\text{ °C}$			2	mA
$I_{EBO}$	Emitter cut-off current ( $I_C = 0$ )	$V_{EB} = 9\text{ V}$			1	mA
$V_{CEO(sus)}$	Collector-emitter sustaining voltage ( $I_B = 0$ )	$I_C = 100\text{ mA}$	700			V
$V_{CE(sat)}^{(1)}$	Collector-emitter saturation voltage	$I_C = 7\text{ A}$ $I_B = 1.75\text{ A}$			2.5	V
$V_{BE(sat)}^{(1)}$	Base-emitter saturation voltage	$I_C = 7\text{ A}$ $I_B = 1.75\text{ A}$			1.1	V
$h_{FE}^{(1)}$	DC current gain	$I_C = 1\text{ A}$ $V_{CE} = 5\text{ V}$		28		
		$I_C = 7\text{ A}$ $V_{CE} = 1\text{ V}$		5.5		
		$I_C = 7\text{ A}$ $V_{CE} = 5\text{ V}$	6		8.5	
$t_s$ $t_f$	INDUCTIVE LOAD	$I_C = 6\text{ A}$ $f_h = 64\text{ kHz}$				
	Storage time	$I_{B(on)} = 0.9\text{ A}$ $V_{BE(off)} = -2.7\text{ V}$		2.3	2.8	$\mu\text{s}$
	Fall time	$L_{BB(off)} = 1.6\text{ }\mu\text{H}$		0.12	0.25	$\mu\text{s}$

1. Pulse test: pulse duration  $\leq 300\text{ }\mu\text{s}$ , duty cycle  $\leq 2\%$ .

## 2.1 Typical characteristics

Figure 2. Safe operating area

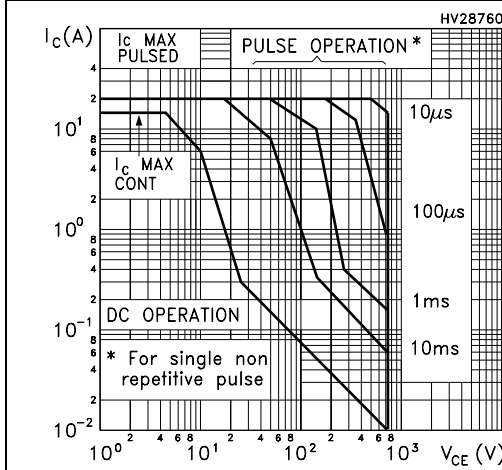

Figure 3. Derating curve

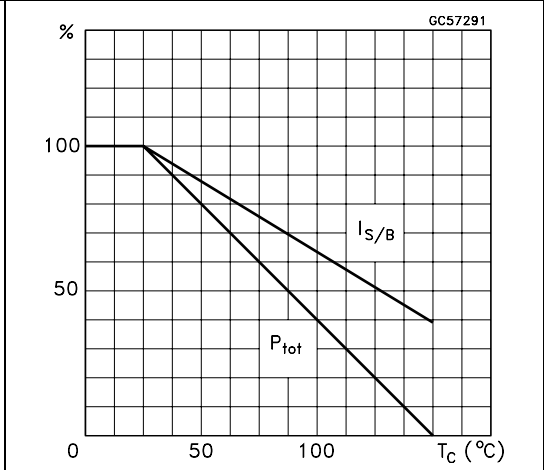

Figure 4. Output characteristics

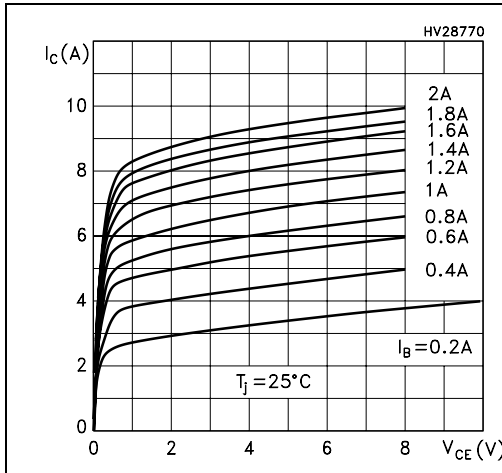

Figure 5. Reverse biased SOA

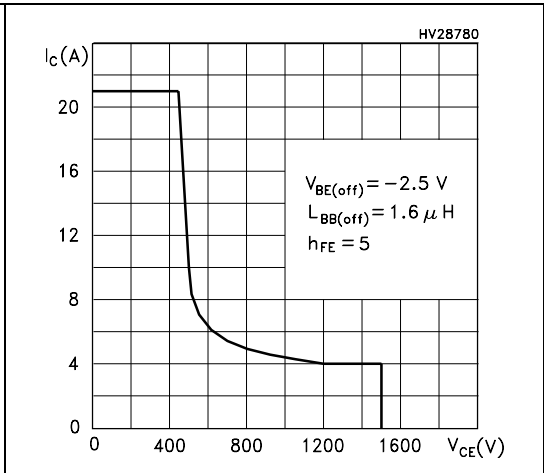

Figure 6. DC current gain ( $V_{CE} = 1$  V)

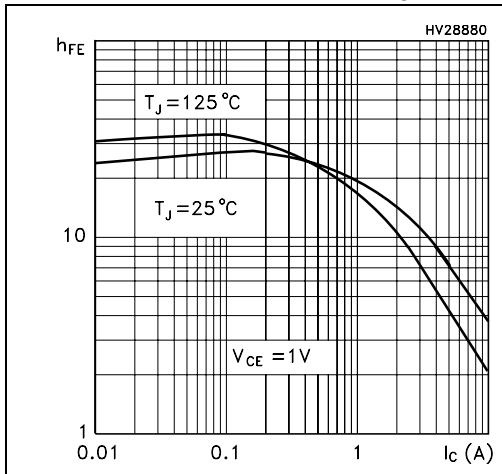
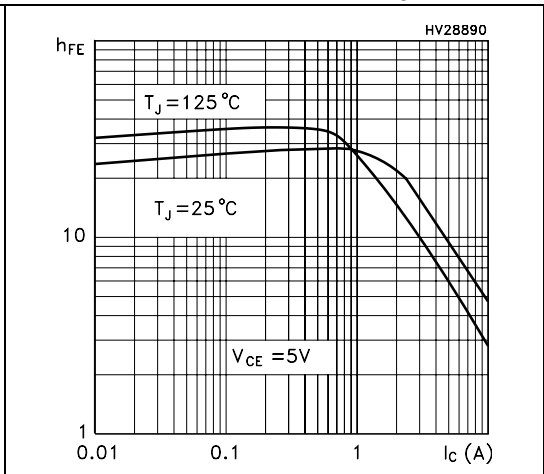
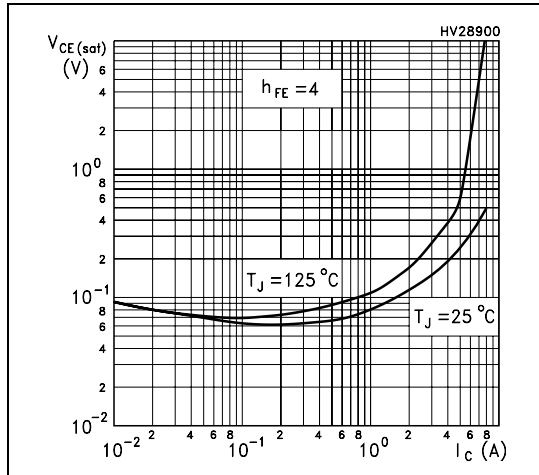

Figure 7. DC current gain ( $V_{CE} = 5$  V)



**Figure 8. Collector-emitter saturation voltage**



**Figure 9. Base-emitter saturation voltage**

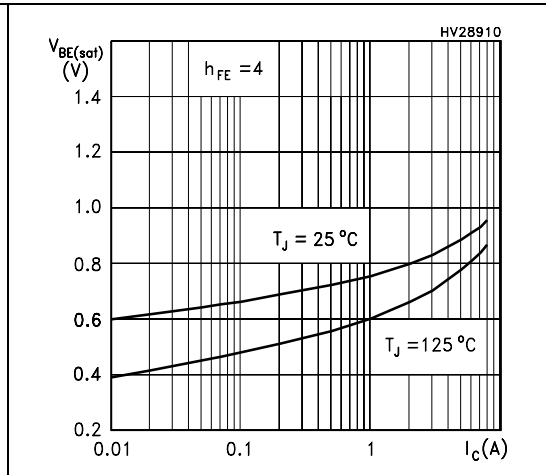

**Figure 10. Power losses**

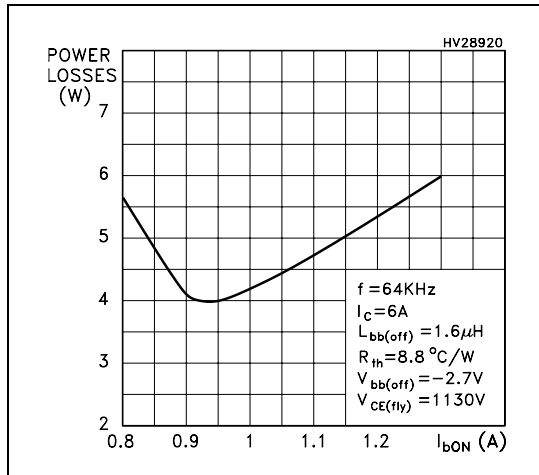

**Figure 11. Inductive load switching time**

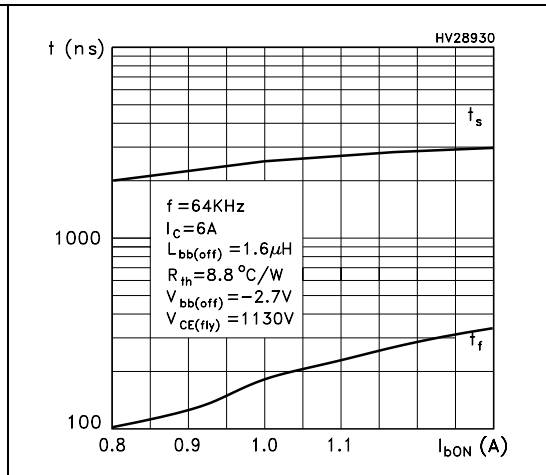

### 3 Test circuits

Figure 12. Power losses and inductive load switching test circuit

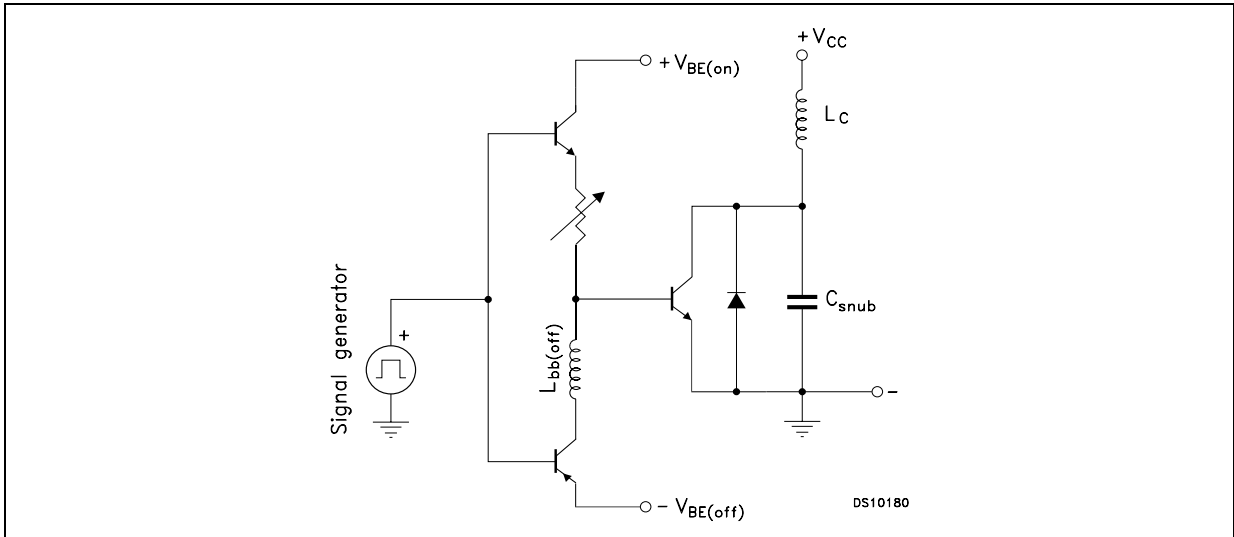
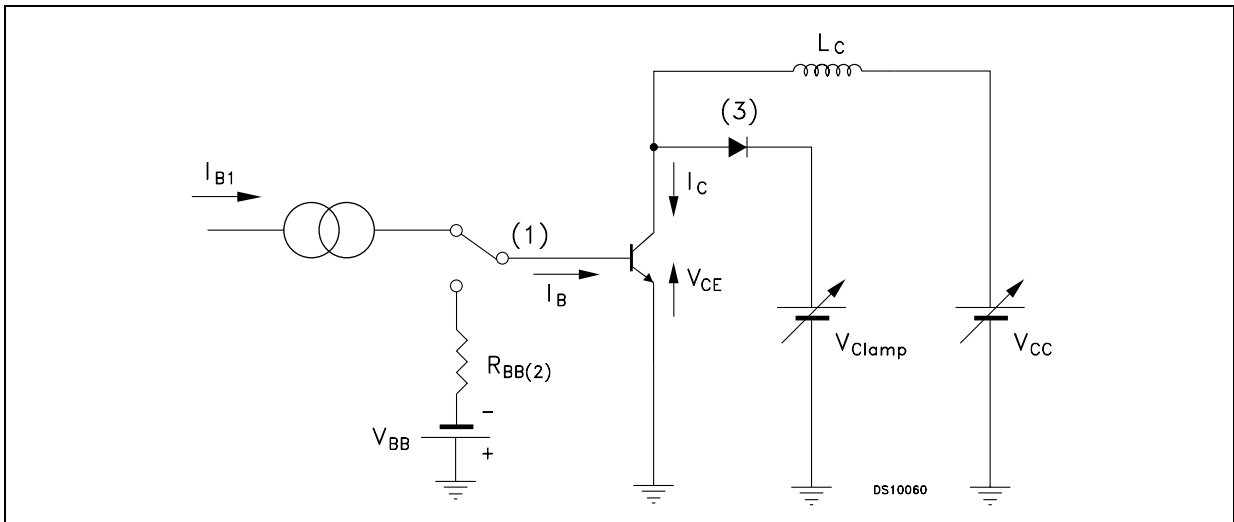

Figure 13. Reverse biased safe operating area test circuit



## 4 Package mechanical data

In order to meet environmental requirements, ST offers these devices in different grades of ECOPACK<sup>®</sup> packages, depending on their level of environmental compliance. ECOPACK<sup>®</sup> specifications, grade definitions and product status are available at: [www.st.com](http://www.st.com). ECOPACK<sup>®</sup> is an ST trademark.

**TO-3PF mechanical data**

DIM.	mm.		
	min.	typ	max.
A	5.30		5.70
C	2.80		3.20
D	3.10		3.50
D1	1.80		2.20
E	0.80		1.10
F	0.65		0.95
F2	1.80		2.20
G	10.30		11.50
G1		5.45	
H	15.30		15.70
L	9.80	10	10.20
L2	22.80		23.20
L3	26.30		26.70
L4	43.20		44.40
L5	4.30		4.70
L6	24.30		24.70
L7	14.60		15
N	1.80		2.20
R	3.80		4.20
Dia	3.40		3.80

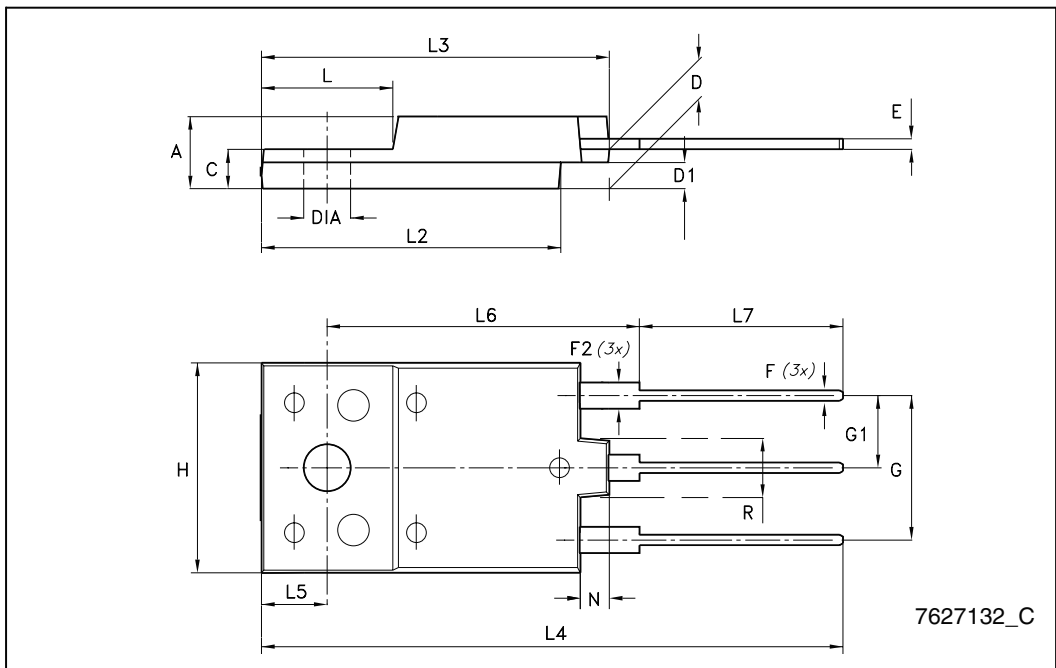



## 5 Revision history

**Table 5. Document revision history**

<b>Date</b>	<b>Revision</b>	<b>Changes</b>
18-Oct-2005	1	First release
25-Nov-2005	2	Complete datasheet
15-Dec-2005	3	Legal page inserted
29-Sep-2006	4	New $h_{FE}$ limit
27-Oct-2009	5	Updated TO-3PF package mechanical data