

ATLAS® Digital Amplifiers

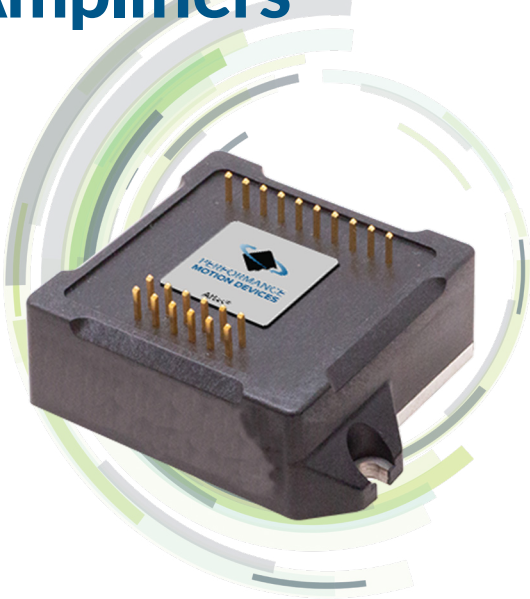

ATLAS® Digital Amplifiers are compact single-axis amplifiers that provide high performance torque control for DC Brush, Brushless DC, and step motors. They are packaged in a compact, solderable module and are ideal for use in positioning motion control, velocity control, and precision force control applications.

High Performance in an Ultra Compact Package

ATLAS Digital Amplifiers are used for direct control of motor torque, or in conjunction with higher level motion controllers. Their very compact size and high power output make them ideally suited for applications such as medical equipment, laboratory automation, scientific instruments, general purpose motion control, force feedback, and actuator controls. ATLAS Amplifiers are provided in vertical and horizontal mounting configurations, with three power levels, and two package sizes.

Advanced Amplifier Technology

ATLAS Digital Amplifiers utilize PMD's proprietary digital current control and switching technology for exceptional efficiency and quiet motor operation. Control features include user-programmable gain parameters, performance trace, field oriented control, and I²t current management. Atlas amplifiers are internally powered from a single motor supply voltage, and provide automatic protection from overcurrent, undervoltage, overvoltage, overtemperature, and short circuit faults.

Easy to Use

The ATLAS family has been designed to work seamlessly with PMD's Magellan motion control ICs. Alternatively, they can be used with dedicated FPGAs, digital signal processors, or general purpose microprocessors. Communication is via SPI (Serial Peripheral Interface) using a simple, packet-oriented protocol. For step motors, in addition to the SPI format a pulse and direction input mode is provided.

FEATURES

- Ultra efficient all digital solderable power amplifier
- Controls Brushless DC, step, and DC Brush motors
- Available in 75 W, 250 W, and 500 W power levels
- Operating supply voltage range of 12 V to 56 V
- Field oriented control
- Overcurrent, overvoltage, and undervoltage protection
- Single supply operation from motor bus voltage
- Fully digital current control
- I²t current foldback limiting
- On-board performance trace and motor parameter storage in NVRAM
- Multi-motor version allows motor type to be programmed by user
- SPI (Serial Peripheral Interface) eliminates analog +/- 10 V torque signals
- Pulse and direction input for step motor operation
- Internal temperature monitor
- Two different package sizes available
- Enable input and Fault output safety interlocks
- Works with Magellan® ICs, FPGAs or microprocessor-based controllers
- Comes in horizontal and vertical mount configurations
- Digital SPI torque command with checksum
- Industry leading efficiency and power density
- Full RoHS compliant and CE marked
- Up to 14A continuous, 25A peak motor output
- User programmable current loop gain values

CONFIGURATION

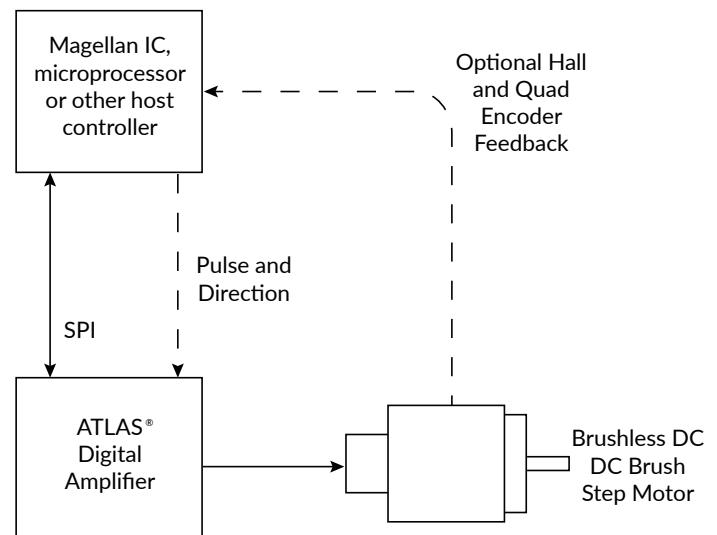

Technical Overview

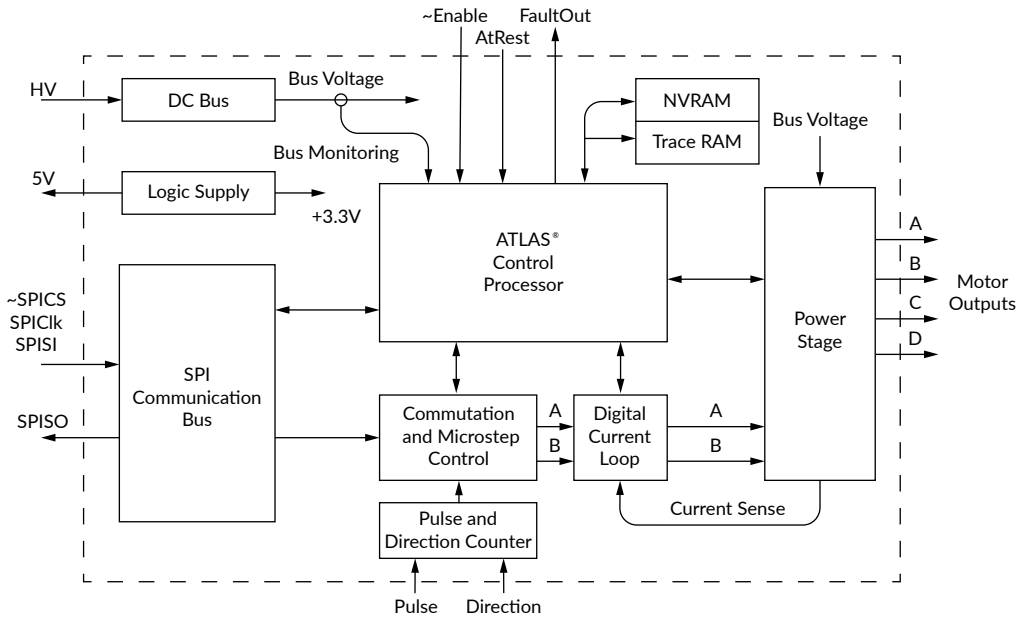

MECHANICAL DIMENSIONS

Horizontal Configuration

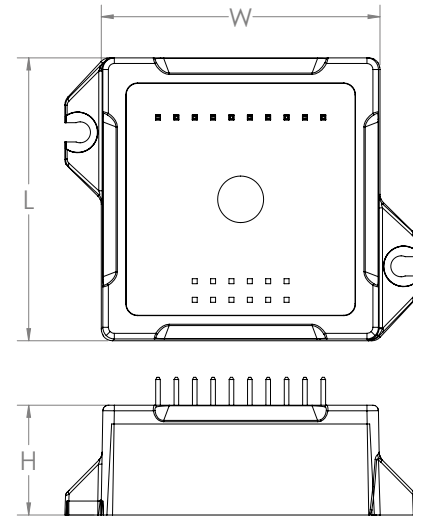

ATLAS FAMILY SPECIFICATIONS

Parameter	Value
Supported Motor Types	Brushless DC, step motor, DC Brush, and multi-motor
PWM frequency	20, 40, 80, 120 kHz
Current Loop rate	20 kHz
Microstepping resolution	256 microsteps per full step
User Programmability:	Non-volatile RAM user configuration storage
Trace Memory:	2 KB
I/Os:	FaultOut, Enable
Safety:	Short Circuit, OverCurrent, I ² t Current Foldback, SPI Watchdog, Overvoltage, Undervoltage
Operating Temperature:	0° - 40° C
Compliance:	RoHs, CE LVD:EN60204-1, EMC-D: EN61000-6-1, EN61000-6-3, EN55011
UL:	Designed to UL508C, UL840, and EN60204-1

Vertical Configuration

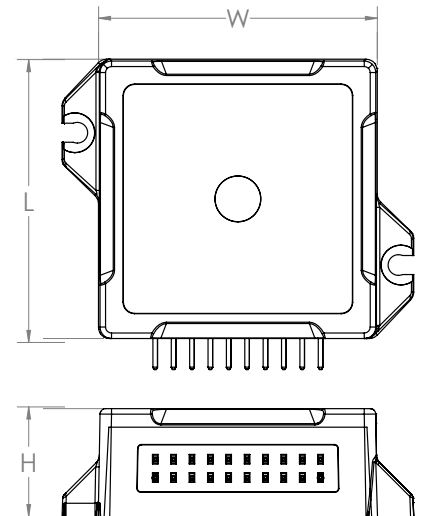

ATLAS MODELS SPECIFICATIONS

Model	Voltage Input	Peak Current	Continuous Current	Package
Low Power, brushless DC	12-48V	3.8 Amps	1.5 Arms	Ultra Compact
Low Power, step motor	12-48V	3.8 Amps	1.5 Arms	Ultra Compact
Low Power, DC brush	12-48V	3.8 Amps	1.5 ADC	Ultra Compact
Medium Power, brushless DC	12-48V	12.5 Amps	5.0 Arms	Ultra Compact
Medium Power, step motor	12-48V	12.5 Amps	4.5 Arms	Ultra Compact
Medium Power, DC brush	12-48V	12.5 Amps	7.0 ADC	Ultra Compact
High Power, brushless DC	12-56V	25.0 Amps	10.0 Arms	Compact
High Power, step motor	12-56V	25.0 Amps	9.0 Arms	Compact
High Power, DC brush	12-56V	25.0 Amps	14.0 ADC	Compact

Model	Length (L)	Width (W)	Height (H)
Ultra Compact Vertical	1.054 (in) 26.8 (mm)	1.051 (in) 26.7 (mm)	0.526 (in) 13.4 (mm)
Ultra Compact Horizontal	1.054 (in) 26.8 (mm)	1.051 (in) 26.7 (mm)	0.526 (in) 13.4 (mm)
Compact Vertical	1.520 (in) 38.6 (mm)	1.517 (in) 38.5 (mm)	0.600 (in) 15.2 (mm)
Compact Horizontal	1.520 (in) 38.6 (mm)	1.517 (in) 38.5 (mm)	0.600 (in) 15.2 (mm)

Development Tools

1 EASY START-UP Developers Kit

INCLUDES

- 1 or 4 axis configuration supports all Atlas unit types
- Pro-Motion software
- Includes rugged L-bracket hardware
- Complete manual set
- Complete cable and prototyping connector set



2 TUNE & CONFIGURE Pro-Motion® GUI

Pro-Motion is a sophisticated, easy-to-use Windows-based exerciser program for use with PMD amplifiers, motion control ICs, modules, and boards.

FEATURES

- Motion oscilloscope graphically displays parameters in real-time
- Easy motor setup with Axis wizard
- Autotuning of control parameters
- Advanced Bode frequency machine analysis
- Ability to save and load configuration parameters in NVRAM
- Trace capability for analyzing motor behavior

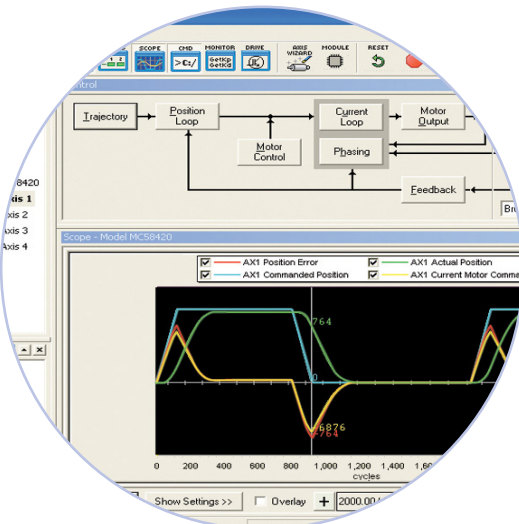

3 BUILD THE APPLICATION C-Motion®

Atlas Developer Kits are most often used in conjunction with either the DK58420 or the DK58113 Magellan IC Developer Kits.

C-MOTION & MAGELLAN IC DEVELOPER'S KIT FEATURES

- Develop embeddable C/C++ application code
- Connects to encoder feedback signals, limit switches, and other motion peripherals
- Control and exercise your entire machine
- Communicate to the PC via PC/104, serial, CAN, or SPI communications
- Store NVRAM parameters

```
code for executing a profile and trace...
captured in this example could be used for tuning the Pro...
trace buffer wrap mode to a one time trace
TraceMode(hAxis1, PMDTraceOneTime);

set the processor variables that we want to capture
SetTraceVariable(hAxis1, PMDTraceVariable1, PMDAxis1,
SetTraceVariable(hAxis1, PMDTraceVariable2, PMDAxis1,
SetTraceVariable(hAxis1, PMDTraceVariable3, PMDAxis1, P

// set the trace to begin when we issue the next update command
SetTraceStart(hAxis1, PMDTraceConditionNextUpdate);

// set the trace to stop when the MotionComplete event occurs
SetTraceStop(hAxis1, PMDTraceConditionEventStatus,
PMDEventMotionCompleteBit, PMDTraceStateHigh);
SetProfileMode(hAxis1, PMDTrapezoidalProfile);

set the profile parameters
SetPosition(hAxis1, 200000);
SetVelocity(hAxis1, 0x200000);
SetAcceleration(hAxis1, 0x1000);
SetDeceleration(hAxis1, 0x1000);

tion
1;
```