

Bridgetek Pte Ltd

ME817EV BT817 Evaluation Board Datasheet

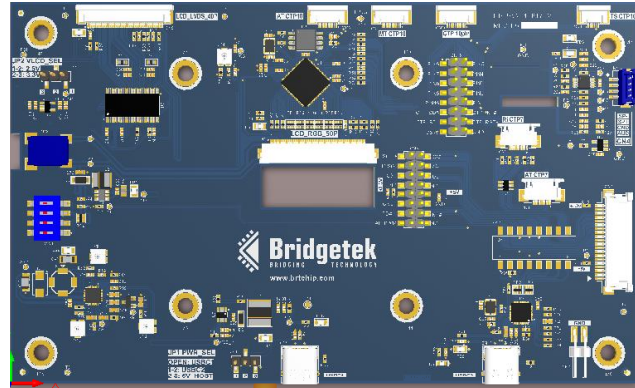

1 Introduction

The ME817EV is a customer evaluation board for Bridgetek's 4th generation EVE chip, BT817. The ME817EV is used to develop and demonstrate BT817's graphics, touch and audio functionalities. The board is capable of supporting LCD panels with 40-pin LVDS interface, or 50-pin RGB interface. Backlight LED current can be adjusted using dip switches. Capacitive touch screens can be connected to the board through a 10-pin or 6-pin FPC connector. An Audio filter and amplifier are included on-board, allowing a 1/8W speaker to be driven. Audio source can be supplied from the BT817, or through a line-in connector.

The ME817EV board supports 2 types of host controller: MCU with SPI/QSPI master, or USB host, selectable through dip switches. The SPI option of the board behaves as a SPI slave, and requires a SPI Master for proper micro-controller interfacing and system integration. The USB option of the board behaves as a USB High-speed device using the FTDI [FT4222H](#), and requires control from a USB host through the Type-C connector.

For a full list of the BT817's features, refer to the [BT817_8 Datasheet](#).

1.1 Features

The ME817EV has the following features:

- Supports 40-pin LVDS display up to 1280x800
- Supports 50-pin RGB display up to 1024x600
- Trimmable on board LCD biasing voltages
- On board LCD backlight LED Driver
- On board audio power amplifier and audio connector for external speaker support
- On board 16Mbyte NOR Flash Memory
- 10-pin or 6-pin FPC connector for capacitive touch screen
- Supports SPI host interface through 2x8 pin header or 20pin FPC connector
- Supports USB High-speed connection with FT4222H
- 5V power supply via SPI host connector, or via USB Type-C port

Neither the whole nor any part of the information contained in, or the product described in this manual, may be adapted or reproduced in any material or electronic form without the prior written consent of the copyright holder. This product and its documentation are supplied on an as-is basis and no warranty as to their suitability for any particular purpose is either made or implied. Bridgetek Pte Ltd will not accept any claim for damages howsoever arising as a result of use or failure of this product. Your statutory rights are not affected. This product or any variant of it is not intended for use in any medical appliance, device or system in which the failure of the product might reasonably be expected to result in personal injury. This document provides preliminary information that may be subject to change without notice. No freedom to use patents or other intellectual property rights is implied by the publication of this document. Bridgetek Pte Ltd, 178 Paya Lebar Road, #07-03, Singapore 409030. Singapore Registered Company Number: 201542387H

2 Ordering Information

Part No.	Description
ME817EV	BT817 customer evaluation board

Table 2-1 – Ordering information

Part No.	Description
MM900EV, MM930Lite, MM932LC	FT9xx Development module
CleO-SPK1	Accessory - CleO speaker enclosure with connecting wires

Table 2-2 – Accessories

Table of Contents

1	Introduction	1
1.1	Features.....	1
2	Ordering Information	2
3	Hardware Description	4
3.1	ME817EV board.....	4
3.2	Physical Descriptions	5
3.2.1	PCB layout.....	5
3.2.2	ME817EV Connectors	6
4	Board Schematics.....	11
5	Hardware Setup	14
5.1	Power Configuration	14
5.2	Backlight LED current Configuration	14
5.3	Compatible LCD panel	14
5.4	Hardware Setup Example 1: MM900EV with 7" LCD	15
5.5	Hardware Setup Example 2: FT4222 with 10.1" LCD.....	17
6	Mechanical Dimensions	19
7	Specifications.....	20
7.1	Electrical Specification	20
8	Contact Information	21
	Appendix A – References	19
	Document References	19
	Acronyms and Abbreviations.....	19
	Appendix B - List of Figures and Tables	20
	List of Figures	20
	List of Tables.....	20
	Appendix C – Revision History	21

3 Hardware Description

Please refer to section [3.2.2](#) for connector settings. Some ME817EV jumpers must be set to work properly with your system.

3.1 ME817EV board

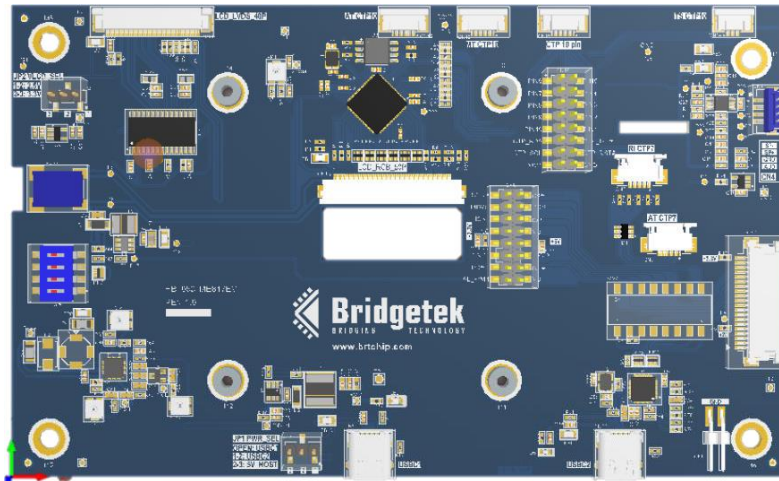

Figure 3-1 – ME817EV board top view

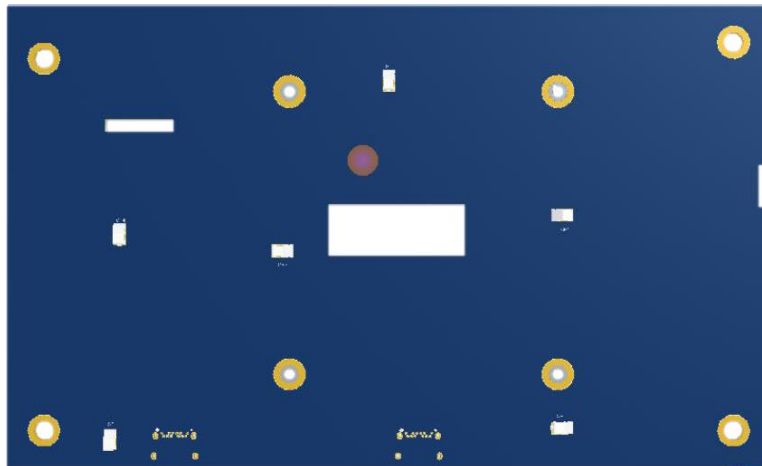

Figure 3-2 – ME817EV board bottom view

The main functions of the ME817EV are as follows:

- USB Type-C or SPI connector for power supply
- 3.3V regulator. Takes 5V input and outputs 3.3V for on-board circuits
- AVDD/VGH/VGL/VCOM biasing voltages for LCD power
- LCD backlight driver. Drive current 120mA – 280mA with over voltage protection (OVP) of 35V
- 3 stage audio filter and power amplifier
- Audio connector for external speaker and audio line in
- 10-pin and 6-pin FPC connector for capacitive touch screen
- On board 16M byte SPI NOR flash memory
- FT4222H USB to QSPI master bridge
- 2x8 pin header for MM900 series microcontroller modules or generic MCU
- 20-pin 1.0mm FPC connector for generic MCU

3.2 Physical Descriptions

3.2.1 PCB layout

The ME817EV is a 160mm x 100mm, four-layer printed circuit board. Board thickness is approximately 1.6mm.

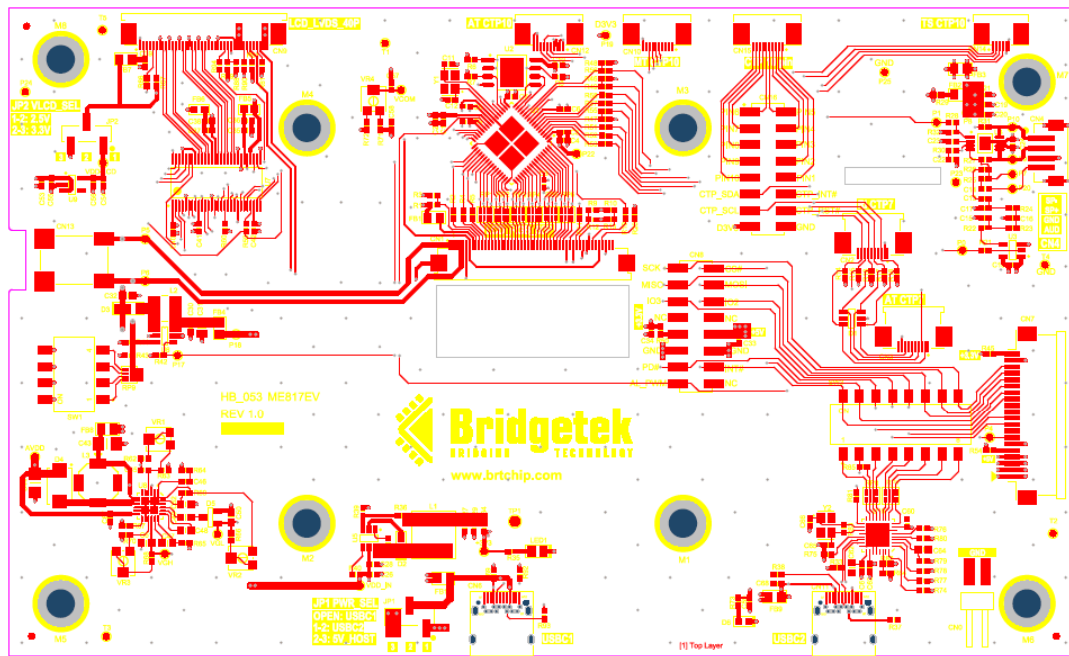

Figure 3-3 – ME817EV board top layer

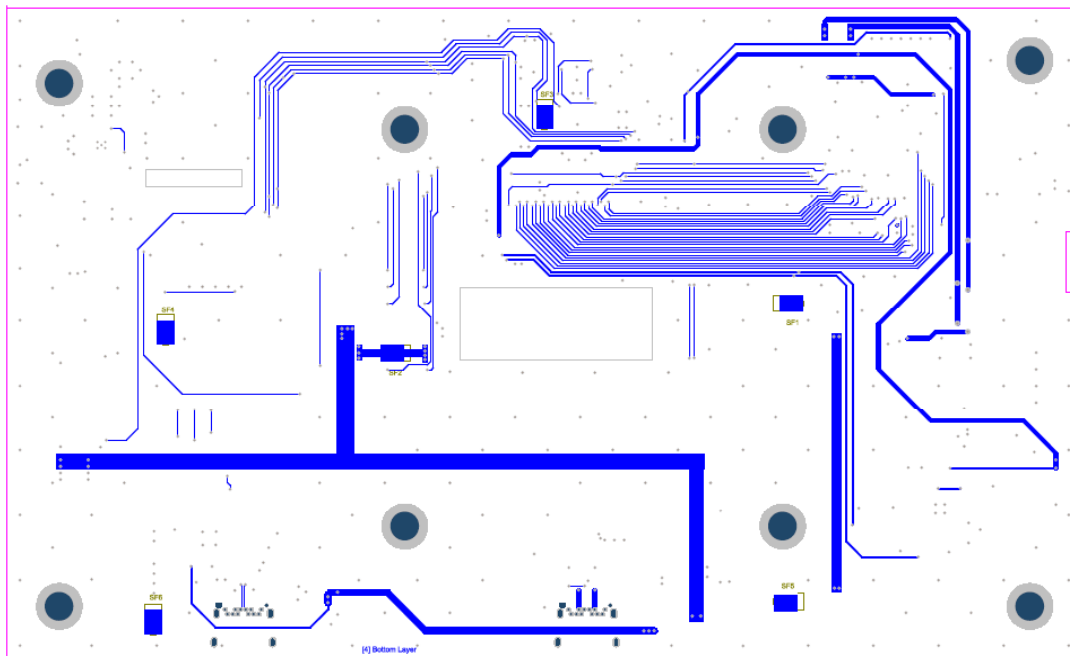

Figure 3-4 – ME817EV board bottom layer

3.2.2 ME817EV Connectors

Connectors and jumpers are described in the following sections.

- **JP1 – Power source select for the board**

JP1 is the jumper option for users to select the 5V power supply source for the board.

Pin Option	Description
OPEN	5V Power from CN6 USBC1 VBUS
1-2 SHORT	5V Power from CN11 USBC2 VBUS (CN6 must not connect)
2-3 SHORT	5V Power from CN7 or CN8 5V_HOST (CN6 must not connect)

Table 3-1 – JP1 Pin options

- **JP2 – Power source select for the 40-pin LVDS panel**

JP2 is the jumper option for users to select the 2.5V/3.3V power supply for the 40-pin LVDS panel (CN9).

Pin Option	Description
1-2 SHORT	Select 2.5V power supply
2-3 SHORT	Select 3.3V power supply

Table 3-2 – JP2 Pin options

- **CN1 – 50-pin RGB LCD Flex Cable connector, 0.5mm, bottom contact**

This connector is the interface between the BT817 IC and the LCD Module. Compatible with many LCD panels with 50-pin RGB interface such as the Riverdi RiTFT-70H.

Pin No.	Name	Type	Description
1-2	LEDA	P	Power for LED backlight (Anode)
3-4	LEDK	P	Power for LED backlight (Cathode)
5	GND	P	Ground
6	VCOM	P	Common voltage
7	DVDD	P	Power for digital circuit, 3.3V
8	MODE	O	DE/SYNC mode select
9	DE	O	Data enable
10	VS	O	Vertical Sync
11	HS	O	Horizontal Sync
12	B7	O	RGB Blue data
13	B6	O	RGB Blue data
14	B5	O	RGB Blue data
15	B4	O	RGB Blue data
16	B3	O	RGB Blue data
17	B2	O	RGB Blue data
18	B1	O	RGB Blue data
19	B0	O	RGB Blue data
20	G7	O	RGB Green data
21	G6	O	RGB Green data
22	G5	O	RGB Green data
23	G4	O	RGB Green data
24	G3	O	RGB Green data
25	G2	O	RGB Green data
26	G1	O	RGB Green data
27	G0	O	RGB Green data
28	R7	O	RGB Red data
29	R6	O	RGB Red data

Pin No.	Name	Type	Description
30	R5	O	RGB Red data
31	R4	O	RGB Red data
32	R3	O	RGB Red data
33	R2	O	RGB Red data
34	R1	O	RGB Red data
35	R0	O	RGB Red data
36	GND	P	Ground
37	DCLK	O	Pixel clock
38	GND	P	Ground
39	L/R	O	Left/Right selection
40	U/D	O	Up/Down selection
41	VGH	P	Gate ON Voltage
42	VGL	P	Gate OFF Voltage
43	AVDD	P	Power for analog circuits
44	DISP	O	LCD Enable
45	NC	-	No connection
46	VCOM	P	Common voltage
47	NC	-	No connection
48	GND	P	Ground
49	NC	-	No connection
50	NC	-	No connection

Table 3-3 – CN1 Pinout

- **CN2 – FPC-10 0.5mm connector, top contact**

This connector is for the capacitive touch panel connection. Compatible with 7" Riverdi touch panels.

Pin No.	Name	Type	Description
1	VSS	P	Ground
2	VDD	P	3.3V power supply
3	SCL	I/O	I2C SCL line
4	NC	NA	No connection
5	SDA	I/O	I2C SDA line
6	NC	NA	No connection
7	RST#	I/O	Touch reset
8	WAKE#	I/O	Pull-up to 3.3V with 3.3K resistor
9	INT#	I/O	Touch interrupt
10	VSS	P	Ground

Table 3-4 – CN2 Pinout

- **CN4 – Audio connector**

ME817EV supports mono audio output through CN4. A ready-made speaker module (CleO-SPK1) is available from Bridgetek. Visit Bridgetek's [on-line shop](#) for more information.

Pin No.	Name	Type	Description
1	SP-	O	Audio speaker out negative
2	SP+	O	Audio speaker out positive
3	AGND	P	Audio Ground
4	LINE_IN	I	External audio line in

Table 3-5 – CN4 Pinout

- **CN6 – USB Type-C receptacle**

USB 5V power input. Type-C 5V/1.5A sink.

Pin No.	Name	Type	Description
A4, B4, A9, B9	VBUS	P	5V power input
A1, B1, A12, B12	GND	P	Ground
A5	CC1	I/O	USB CC1 line, 5.1K pull down resistor.
B5	CC2	I/O	USB CC2 line, 5.1K pull down resistor.

Table 3-6 – CN6 Pinout

- **CN7 and CN8 - SPI host interface**

This is the interface where the SPI control and data signals are routed. There are also power and ground pins on this interface. CN8 is a 2x8 pin header, compatible with the Bridgetek MM900 series modules. CN7 is a 20-pin FPC connector which can be used to connect to the MCU board through an FPC cable.

Pin No (CN8)	Pin No (CN7)	Name	Type	Description
1	18	MA_SCK	I	SPI clock input
2	15	MA_CS#	I	SPI chip select, active low
3	17	MA_MISO	I/O	SPI master input, slave output or Quad SPI IO1
4	16	MA_MOSI	I/O	SPI master output, slave input or Quad SPI IO0
5	9	MA_IO3	I/O	GPIO1 or Quad SPI IO3
6	10	MA_IO2	I/O	GPIO0 or Quad SPI IO2
7-8	11-12	NC	-	No connection
9	5,20	NC	-	No connection
10	3,4	5V_HOST	P	5V power supply
11	1,2	GND	P	Ground
12	6,19	GND	P	Ground
13	13	MA_PD#	I	Powers down and reset input, active low. Connect to 3.3V if not used.
14	14	MA_INT#	O	Interrupts output, active low. On board 4.7kΩ pull-up to 3.3V.
15	-	AUDIO_L	O	AUDIO_L output from BT817
16	8	NC	-	No connection
-	7	GPIO3	I/O	GPIO3 pin of BT817

Table 3-7 – CN7 & CN8 Pinout

- **CN9 – 40-pin LVDS LCD Flex Cable connector, 0.5mm, top contact**

This connector is the interface between the RGB-LVDS converter IC and the LCD Module. Compatible with many LCD panels with 40-pin LVDS interface such as the A-TOPS AT-T101QIH.

Pin No.	Name	Type	Description
1	VCOM	P	Common voltage
2-3	VDD	P	Power supply, 2.5V or 3.3V
4	GND	P	Ground
5	DISP	O	Display enable
6	STDBY	O	Standby mode, pulled-high
7	GND	P	Ground
8	TX0_N	O	LVDS data output
9	TX0_P	O	LVDS data output
10	GND	P	Ground
11	TX1_N	O	LVDS data output

Pin No.	Name	Type	Description
12	TX1_P	O	LVDS data output
13	GND	P	Ground
14	TX2_N	O	LVDS data output
15	TX2_P	O	LVDS data output
16	GND	P	Ground
17	TXCLK_N	O	LVDS clock output
18	TXCLK_P	O	LVDS clock output
19	GND	P	Ground
20	TX3_N	O	LVDS data output
21	TX3_P	O	LVDS data output
22	GND	P	Ground
23-24	NC	-	No connection
25	GND	P	Ground
26-27	NC	-	No connection
28	SELB	O	Select 6/8 bit mode. Pulled-low
29	AVDD	P	Power for analog circuits
30	GND	P	Ground
31-32	LEDK	P	Power for LED backlight (Cathode)
33	L/R	O	Left/Right selection, pulled-high
34	U/D	O	Up/Down selection, pulled-low
35	VGL	P	Gate OFF Voltage
36-37	NC	-	No connection
38	VGH	P	Gate ON Voltage
39-40	LEDA	P	Power for LED backlight (Anode)

Table 3-8 – CN9 Pinout

- **CN10 – FPC-10 0.5mm connector, bottom contact**

This connector is for capacitive touch panel connection. Compatible with 10.1" Microtech touch panels.

Pin No.	Name	Type	Description
1-4	NC	NA	No connection
5	RST#	I/O	Touch reset
6	INT#	I/O	Touch interrupt
7	SCL	I/O	I2C SCL line
8	SDA	I/O	I2C SDA line
9	GND	P	Ground
10	VCC	P	3.3V power supply

Table 3-9 – CN10 Pinout

- **CN11 – USB Type-C receptacle**

USB data and 5V power input. Type-C 5V/1.5A sink.

Pin No.	Name	Type	Description
A4, B4, A9, B9	VBUS	P	5V power input
A1, B1, A12, B12	GND	P	Ground
A6, B6	D+	I/O	USB D+ data line
A7, B7	D-	I/O	USB D- data line
A5	CC1	I/O	USB CC1 line, 5.1K pull down resistor.
B5	CC2	I/O	USB CC2 line, 5.1K pull down resistor.

Table 3-10 – CN11 Pinout

- **CN12 – FPC-10 0.5mm connector, bottom contact**

This connector is for the capacitive touch panel connection. Compatible with 10.1" A-TOPS touch panels.

Pin No.	Name	Type	Description
1-2	GND	P	Ground
3-4	VCC	P	3.3V power supply
5	SCL	I/O	I2C SCL line
6	SDA	I/O	I2C SDA line
7	RST#	I/O	Touch reset
8	INT#	I/O	Touch interrupt
9-10	GND	P	Ground

Table 3-11 – CN12 Pinout

- **CN13 – Backlight LED connector**

This connector is for the Backlight LED connection.

Pin No.	Name	Type	Description
1	LEDA	P	Power for LED backlight (Anode)
2	LEDK	P	Power for LED backlight (Cathode)

Table 3-12 – CN13 Pinout

- **CN14 – FPC-6 0.5mm connector, bottom contact**

This connector is for the capacitive touch panel connection. Compatible with 10.1" TSD touch panels.

Pin No.	Name	Type	Description
1	SDA	I/O	I2C SDA line
2	SCL	I/O	I2C SCL line
3	RST#	I/O	Touch reset output
4	INT#	I/O	Touch interrupt input
5	GND	P	Ground
6	VDD	P	3.3V power supply

Table 3-13 – CN14 Pinout

4 Board Schematics

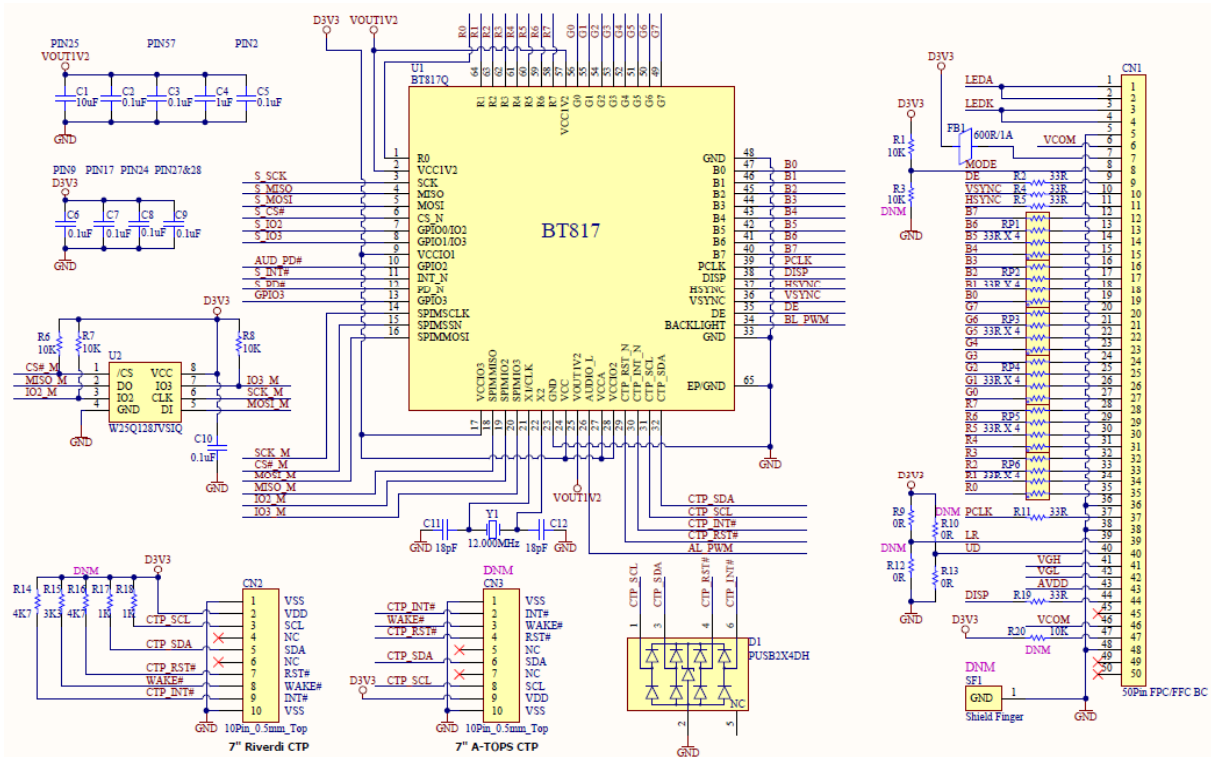

Figure 4-1 - BT817 IC and RGB Connector

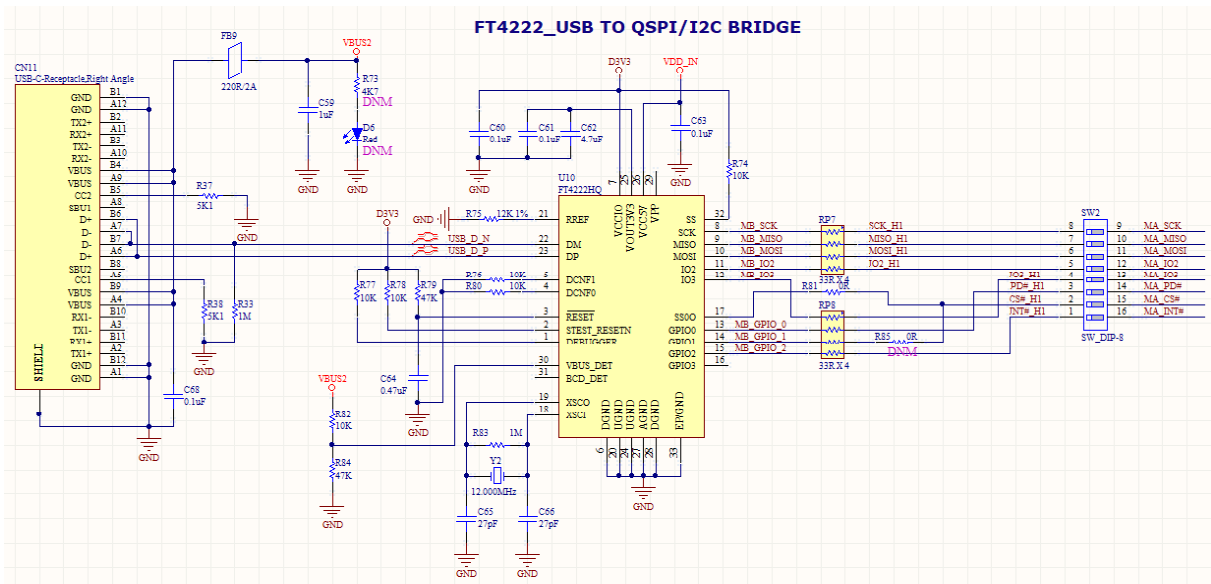
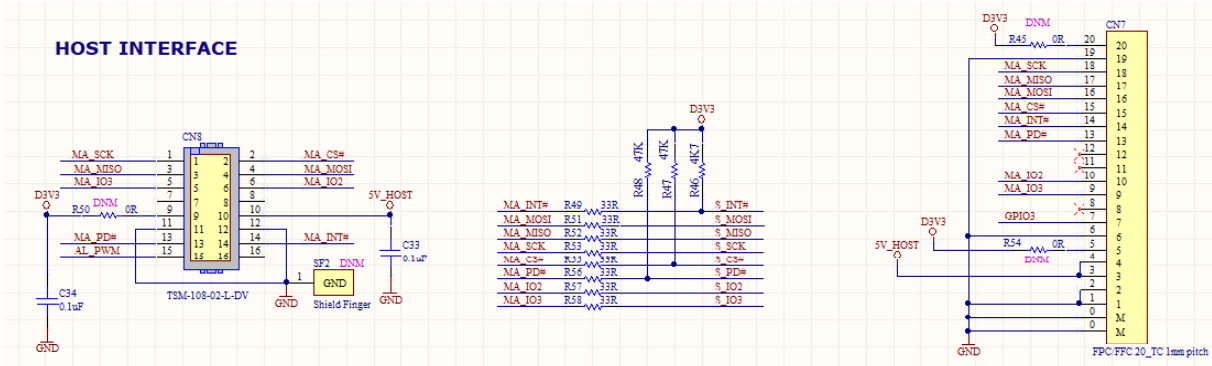
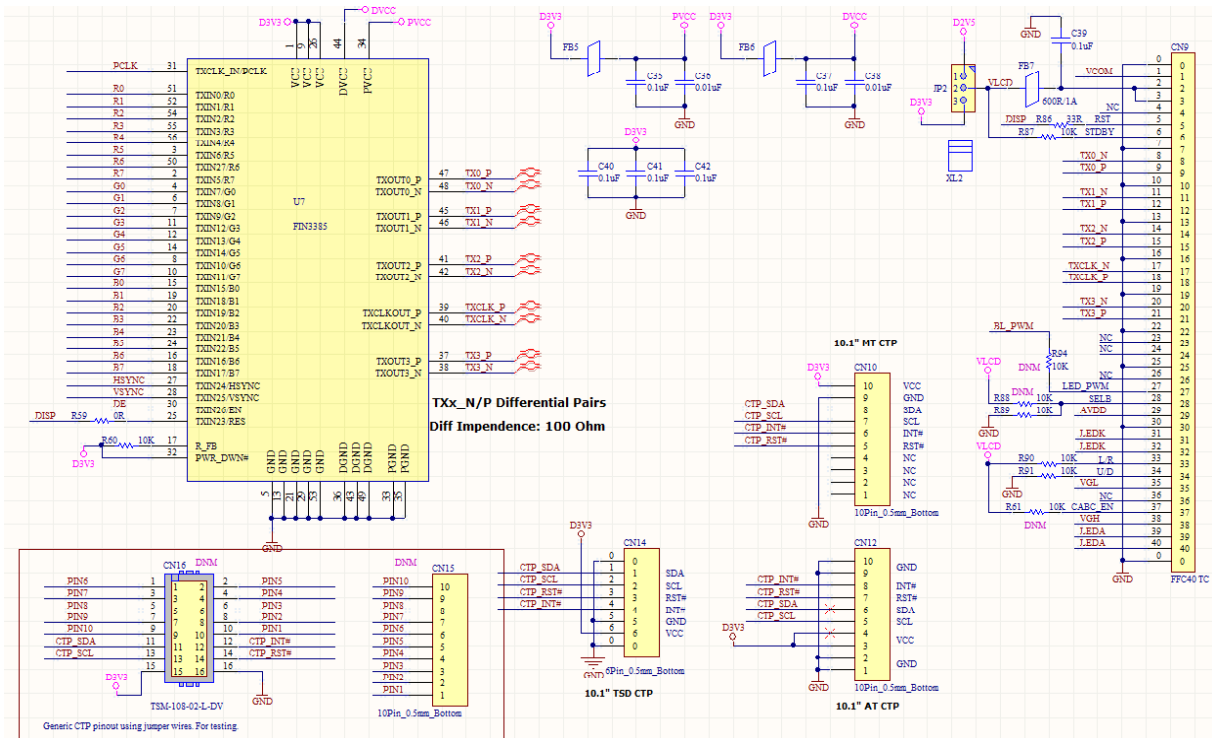

Figure 4-2 - FT4222 USB Bridge Circuit

Figure 4-3 - Host Interface Connectors

Figure 4-4 - RGB to LVDS converter

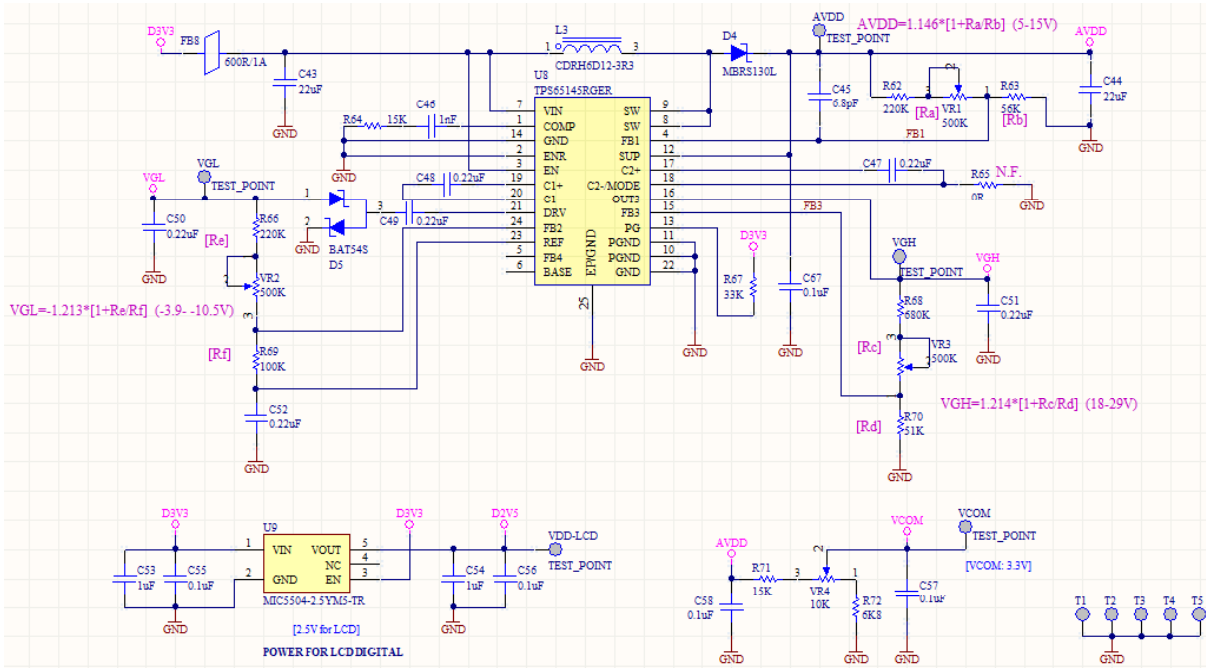

Figure 4-5 - LCD Biasing Voltages

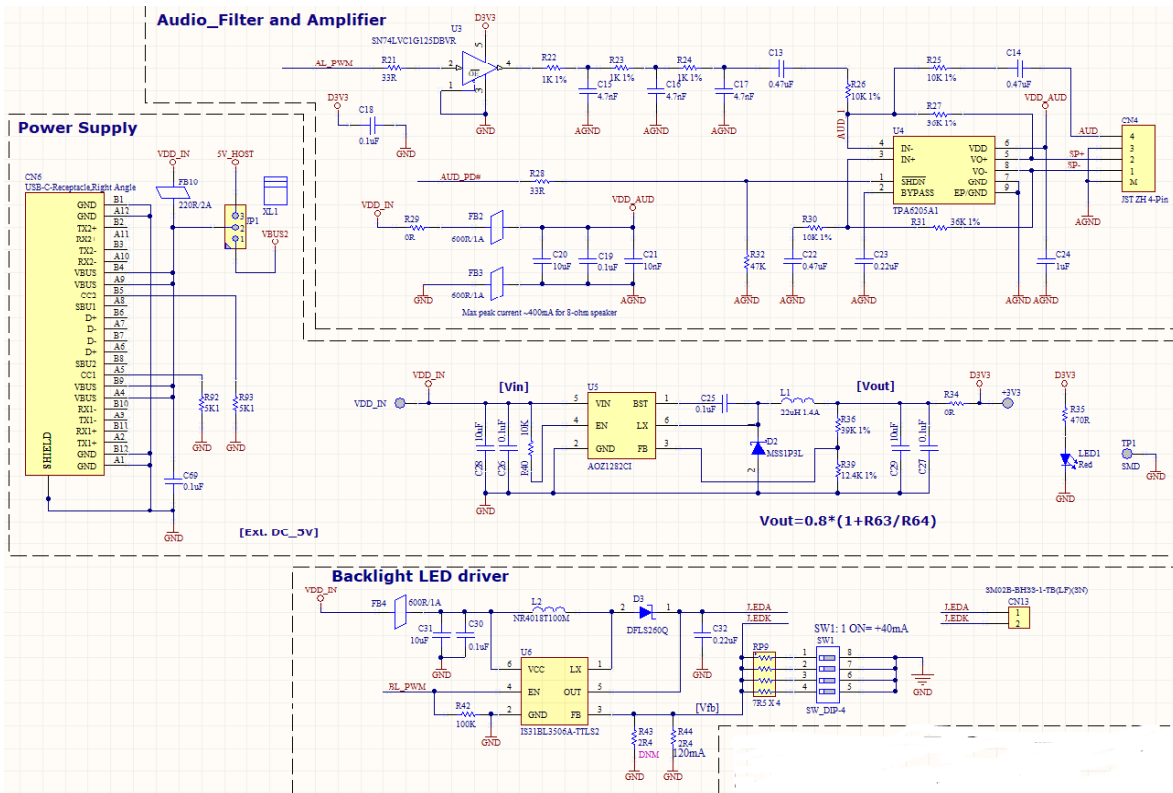

Figure 4-6 - Power and Audio Circuits

5 Hardware Setup

5.1 Power Configuration

There are 3 methods of powering the ME817EV board.

- 1) PC USB port Power(5V) - Connect to PC via Type-C cable to CN11
- 2) USB-C charger Power(5V) - Connect USB charger with Type-C cable to CN6
- 3) Power from MCU host board(5V) - Connect 5V to CN8 pin 10 or CN7 pin 3&4

The following table summarises how to power the ME817EV board using the various methods.

Power Method	CN11	CN6	CN8 Pin 10 (or CN7 pin3&4)	JP1
PC USB port power (5V)	5V	Must not connect	Don't care	Short pin 1-2
USBC charger power (5V)	Don't care	5V	Don't care	open
MCU host board power (5V)	Don't care	Must not connect	5V	Short pin 2-3

Table 5-1 – Board power configuration

5.2 Backlight LED current Configuration

The ME817EV module has a backlight LED driver circuit on-board. The driver takes 5V as an input power source, and the regulator produces the output voltage so that the desired total output current can be drawn by the backlight LED. Users can select backlight current up to a maximum of 280mA via dip switch SW1. By default, with all the 4 switches in SW1 turned OFF, resistor R44 (2.4 Ohm) is setting the minimum backlight current at 120mA. The switches in S12 are connected to array resistor RP9 (4 x 7.5 Ohm). Turning ON each switch will provide an additional backlight current of 40mA per switch.

Backlight LED array	Vled voltage	Vled current	SW1 Number of ON position	Comment
6 x 6	19.2V	120mA	0	
8 x 3	9.6V	160mA	1	
10 x 3	9.6V	200mA	2	
12 x 3	9.6V	240mA	3	
14 x 3	9.6V	280mA	4	

Table 5-2 – Backlight LED configuration

5.3 Compatible LCD panel

The ME817EV supports 2 types of LCD interface:

1. LVDS panel with 40-pin 0.5mm FPC cable or connector
2. RGB panel with 50-pin 0.5mm FPC cable or connector

Table 5-3 lists a few LCD panels which have been tested as working with the ME817EV board.

Vendor	Part No	Size	Resolution	Display Interface	Cap Touch IC /Connector
Riverdi	RiTFT-70H-CAP	7"	1024x600	RGB-50	FT5426/CN2
EastRising	ER-TFT101-1	10.1"	1024x600	RGB-50	-
A-TOPS	AT-T101QIH-48CP	10.1"	1280x800	LVDS-40	GT928/CN12

Vendor	Part No	Size	Resolution	Display Interface	Cap Touch IC /Connector
Microtech	MTF101IA-01D(TFT) MTP101GGY-01(CTP)	10.1"	1280x800	LVDS-40	GT928/CN10

Table 5-3 – Compatible LCD list

5.4 Hardware Setup Example 1: MM900EV with 7" LCD

This example uses a Riverdi 7" TFT with CTP (RiTFT-70H-CAP) for display and touch functions. The host controller will utilize Bridgetek's MM900EV module built with FT900 32-bit MCU controller.

The RiTFT-70H-CAP outline size is the same as the ME817EV PCB. It is possible to put the LCD and PCB together back-to-back to form a display module assembly.

Hardware Setup

- Plug the USB Type-C cable into the CN6-USBC1 connector, with the other end plugged to a USB power source (at least 1.5A current rating)
- Trim variable resistors VR1-VR4 to get required LCD biasing voltages as: AVDD=9.6V, VGL=-6V, VGH=18V, VCOM=3.8V.
- Un-plug the USB Type-C cable to remove the power
- Connect the LCD display 50-pin FPC cable to CN1
- Connect the LCD touch 10-pin FPC cable to CN2
- On SW2, set all 8 positions to OFF. On SW1, set SW1-1 to ON, SW1-2/3/4 to OFF
- Set JP1 to short pin2-3
- Connect the [MM900EV](#) module to CN8. A [UMFTPD2A](#) programming/debug module is also recommended for programming the FT900.
- Plug the USB Type-C cable to turn on the power

Software Setup

- Download EVE Toolchains at <https://brtchip.com/eve-toolchains/> .
- Download EVE sample applications at <https://brtchip.com/SoftwareExamples-eve/> .
- Launch the Sample Application based on FT900 platform.

The [BT81X Programming Guide](#) describes the programming code and formats used by the BT81X. The Sample Application is a well-formatted and documented program that illustrates the Programming Guide, and provides numerous design examples and reference code demonstrations.



Figure 5-1 – MM900 setup with 7" 1024x600 panel



Figure 5-2 – 7" Module assembly

5.5 Hardware Setup Example 2: FT4222 with 10.1" LCD

This example uses an A-TOPS 10.1" 1280x800 TFT with CTP (AT-T101QIH-48CP) for display and touch functions. The host will be PC, connected by utilizing the on-board FTDI FT4222H USB to QSPI bridge.

Hardware Setup

- On SW2, set all 8 positions to ON. On SW1, set all 4 positions to OFF
- Set JP1 to short pin1-2
- Plug the USB Type-C cable to CN11-USBC2 connector, with the other end plugged to PC USB port (at least 1.5A current rating).
- Trim variable resistors VR1-VR4 to get required LCD biasing voltages as: AVDD=8.2V, VGL=-7V, VGH=22V, VCOM=3.3V.
- Un-plug the USB Type-C cable to remove the power
- Connect the LCD display 40-pin FPC connector to CN9 through 40-pin FPC cable
- Connect the LCD touch 10-pin FPC cable to CN12
- Plug the USB Type-C cable to turn on the power

Software Setup

- Follow section 5.4 to download EVE toolchain and sample application.
- When re-compiling the sample application, select EVE_GRAPHICS_ME817EV in the Processor Definitions of SampleApp MSVC Property Pages, as shown in the screenshot below. For more details, please refer to the user manual of EveApps.

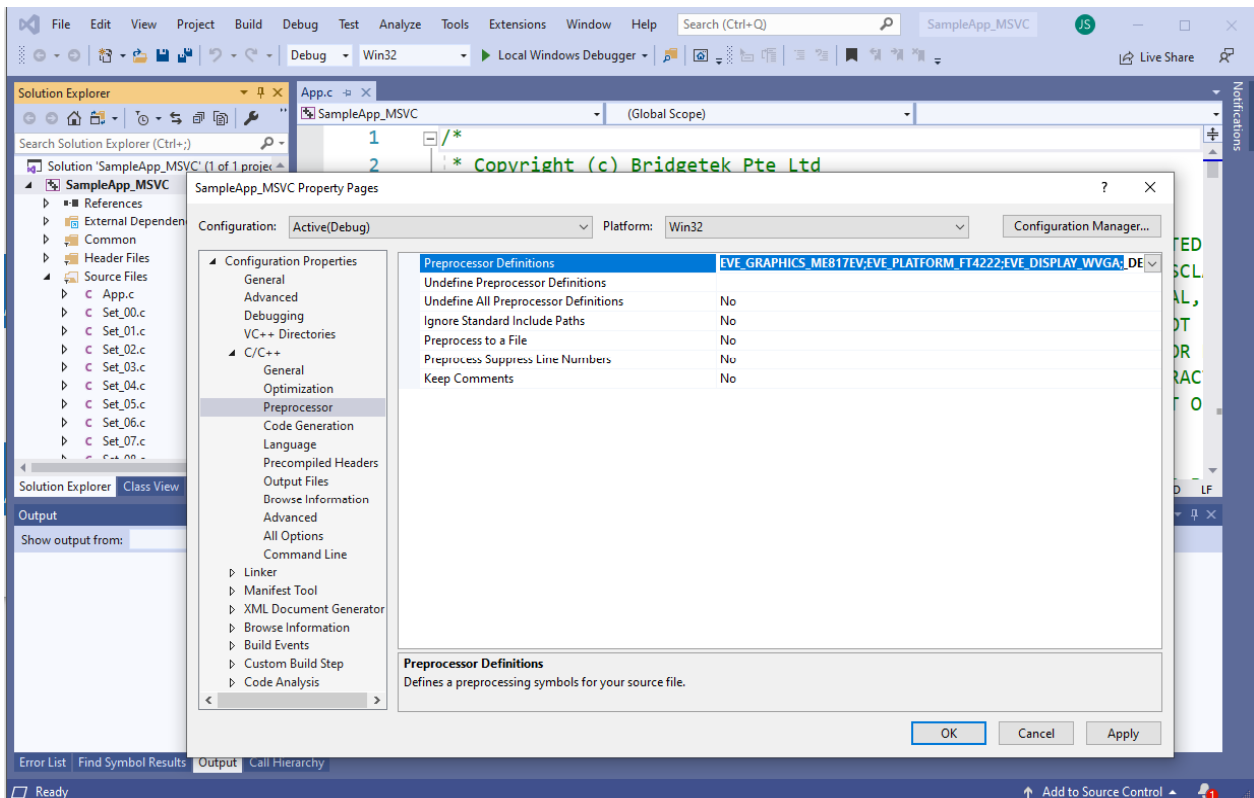

Figure 5-3 – EveApps configuration for ME817EV



Figure 5-4 - PC setup with 10.1" 1280x800 panel

6 Mechanical Dimensions

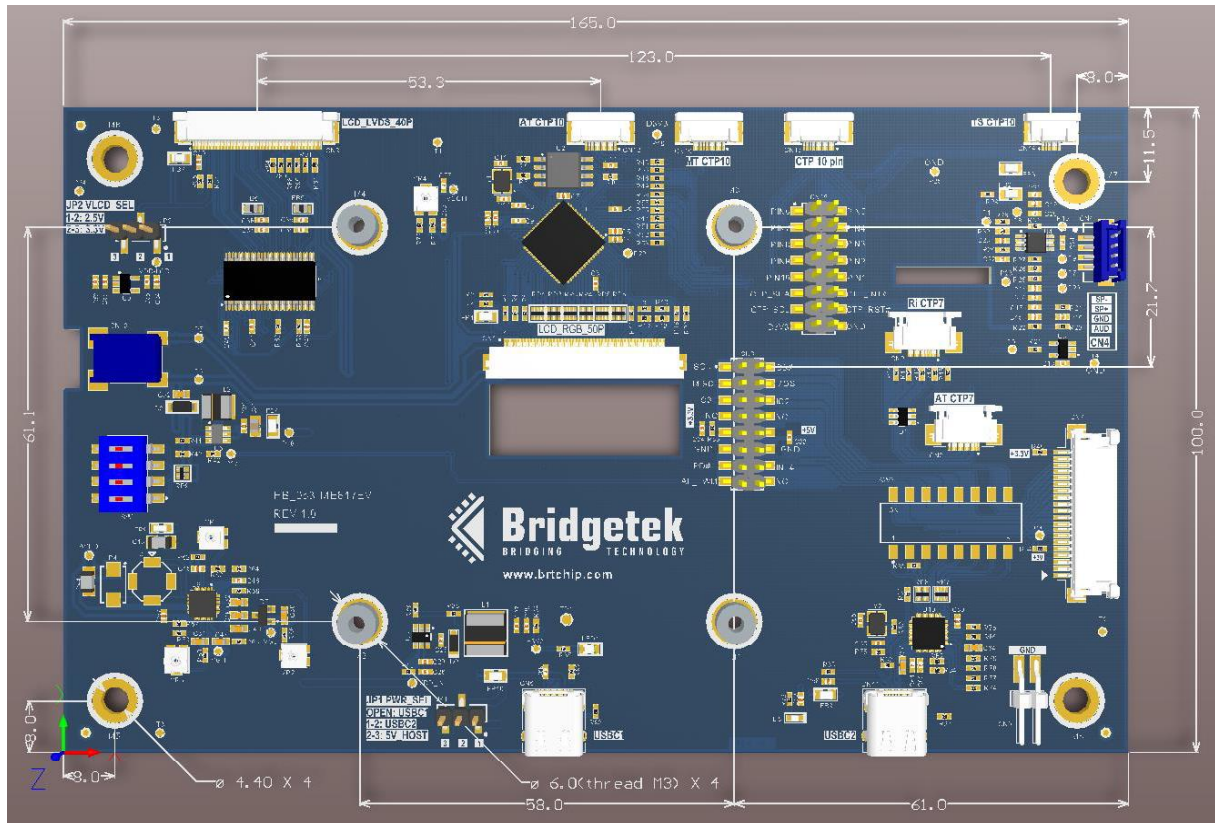

Figure 6-1 – PCB Mechanical Dimensions

7 Specifications

7.1 Electrical Specification

Parameter	Description	Minimum	Typical	Maximum	Units	Notes
VCC_5V	5V supply voltage	4.5	5.0	5.5	V	
Icc1_5V	VCC=5V operating current	-	200	-	mA	Without LCD/speaker
Icc2_5V	VCC=5V operating current	-	950	-	mA	With 7" LCD and 1/8W speaker
Icc3_5V	VCC=5V operating current	-	1200	-	mA	With 10.1" LCD and 1/8W speaker
Voh	Output Voltage High	2.4	-	-	V	
Vol	Output Voltage Low	-	-	0.4	V	
Vih	Input High Voltage	2.0	-	5.25	V	
Vil	Input Low Voltage	-	-	0.8	V	

Table 7-1 - Operating Voltage and Current

8 Contact Information

Head Quarters – Singapore

Bridgetek Pte Ltd
178 Paya Lebar Road, #07-03
Singapore 409030
Tel: +65 6547 4827
Fax: +65 6841 6071

E-mail (Sales) sales.apac@brtchip.com
E-mail (Support) support.apac@brtchip.com

Branch Office – Taipei, Taiwan

Bridgetek Pte Ltd, Taiwan Branch
2 Floor, No. 516, Sec. 1, Nei Hu Road, Nei Hu District
Taipei 114
Taiwan, R.O.C.
Tel: +886 (2) 8797 5691
Fax: +886 (2) 8751 9737

E-mail (Sales) sales.apac@brtchip.com
E-mail (Support) support.apac@brtchip.com

Branch Office - Glasgow, United Kingdom

Bridgetek Pte. Ltd.
Unit 1, 2 Seaward Place, Centurion Business Park
Glasgow G41 1HH
United Kingdom
Tel: +44 (0) 141 429 2777
Fax: +44 (0) 141 429 2758

E-mail (Sales) sales.emea@brtchip.com
E-mail (Support) support.emea@brtchip.com

Branch Office – Vietnam

Bridgetek VietNam Company Limited
Lutaco Tower Building, 5th Floor, 173A Nguyen Van
Tro, Troi,
Ward 11, Phu Nhuan District,
Ho Chi Minh City, Vietnam
Tel : 08 38453222
Fax : 08 38455222

E-mail (Sales) sales.apac@brtchip.com
E-mail (Support) support.apac@brtchip.com

Web Site

<http://brtchip.com/>

Distributor and Sales Representatives

Please visit the Sales Network page of the [Bridgetek Web site](http://brtchip.com/) for the contact details of our distributor(s) and sales representative(s) in your country.

System and equipment manufacturers and designers are responsible to ensure that their systems, and any Bridgetek Pte Ltd (BRT Chip) devices incorporated in their systems, meet all applicable safety, regulatory and system-level performance requirements. All application-related information in this document (including application descriptions, suggested Bridgetek devices and other materials) is provided for reference only. While Bridgetek has taken care to assure it is accurate, this information is subject to customer confirmation, and Bridgetek disclaims all liability for system designs and for any applications assistance provided by Bridgetek. Use of Bridgetek devices in life support and/or safety applications is entirely at the user's risk, and the user agrees to defend, indemnify and hold harmless Bridgetek from any and all damages, claims, suits or expense resulting from such use. This document is subject to change without notice. No freedom to use patents or other intellectual property rights is implied by the publication of this document. Neither the whole nor any part of the information contained in, or the product described in this document, may be adapted or reproduced in any material or electronic form without the prior written consent of the copyright holder. Bridgetek Pte Ltd, 178 Paya Lebar Road, #07-03, Singapore 409030. Singapore Registered Company Number: 201542387H.

Appendix A – References

Document References

<http://brtchip.com/m-eve4/>

[BT817_8 Datasheet](#)

[BT81X Programming Guide](#)

[FT9xx Modules](#)

Acronyms and Abbreviations

Terms	Description
EVE	Embedded Video Engine
LCD	Liquid Crystal Display
PC	Personal Computer
SPI	Serial Peripheral Interface
TFT	Thin Film Transistor
USB	Universal Serial Bus

Appendix B - List of Figures and Tables

List of Figures

Figure 4-1 - BT817 IC and RGB Connector.....	11
Figure 4-2 - FT4222 USB Bridge Circuit.....	11
Figure 4-3 - Host Interface Connectors	12
Figure 4-4 - RGB to LVDS converter	12
Figure 4-5 - LCD Biasing Voltages	13
Figure 4-6 - Power and Audio Circuits	13
Figure 5-1 – MM900 setup with 7” 1024x600 panel.....	16
Figure 5-2 – 7” Module assembly	16
Figure 5-3 – EveApps configuration for ME817EV.....	17
Figure 5-4 - PC setup with 10.1” 1280x800 panel	18
Figure 6-1 – PCB Mechanical Dimensions.....	19

List of Tables

Table 2-1 – Ordering information	2
Table 3-1 – JP1 Pin options	6
Table 3-2 – JP2 Pin options	6
Table 3-3 – CN1 Pinout	7
Table 3-4 – CN2 Pinout	7
Table 3-5 – CN4 Pinout	7
Table 3-6 – CN6 Pinout	8
Table 3-7 – CN7 & CN8 Pinout	8
Table 3-8 – CN9 Pinout	9
Table 3-9 – CN10 Pinout.....	9
Table 3-10 – CN11 Pinout	9
Table 3-11 – CN12 Pinout	10
Table 3-12 – CN13 Pinout.....	10
Table 3-13 – CN14 Pinout	10
Table 5-1 – Board power configuration.....	14
Table 5-2 – Backlight LED configuration	14
Table 5-3 – Compatible LCD list.....	15
Table 7-1 - Operating Voltage and Current	20