



MEZS6-35V2A Stepper Driver

2.5A, 35V, Bipolar Stepper Motor Driver Solution Kit

DESCRIPTION

The MEZS6-35V2A Stepper Driver is a stepper motor controller/driver board using the MP6501AGF, a stepper motor driver with a built-in micro-stepping translator. An on-board microcontroller can generate stepping control signals, and be controlled from a PC using a USB connection and Windows GUI program.

It operates from a supply voltage range of 8V to 35V and can deliver motor current up to 2.5A. It can drive a bipolar stepper motor in full-, half-, quarter-, and eighth- step modes by setting the MS3, MS2, MS1. The input control signals and reference voltage for the MP6501AGF are applied through the connector or generated on board.

ELECTRICAL SPECIFICATIONS

Parameter	Symbol	Value	Units
Input voltage	V _{IN}	8 to 35	V
Output current	I _{OUT}	2.5	A

FEATURES

- Wide 8V to 35V Input Voltage Range
- Up to 2.5A Programmable Output Current
- Full-, Half-, Quarter-, and Eighth-Step Modes
- Adjustable Mixed Decay Ratio or Automatic Decay
- OCP, OVP, and OTP
- Control Signals Generated by On-Board USB Microcontroller or Supplied Externally

APPLICATIONS

- Printers
- General Bipolar Stepper Drivers

All MPS parts are lead-free, halogen-free, and adhere to the RoHS directive. For MPS green status, please visit the MPS website under Quality Assurance. "MPS", the MPS logo, and "Simple, Easy Solutions" are trademarks of Monolithic Power Systems, Inc. or its subsidiaries.

MEZS6-35V2ASTEPPERDRIVER SOLUTION KIT BOARD

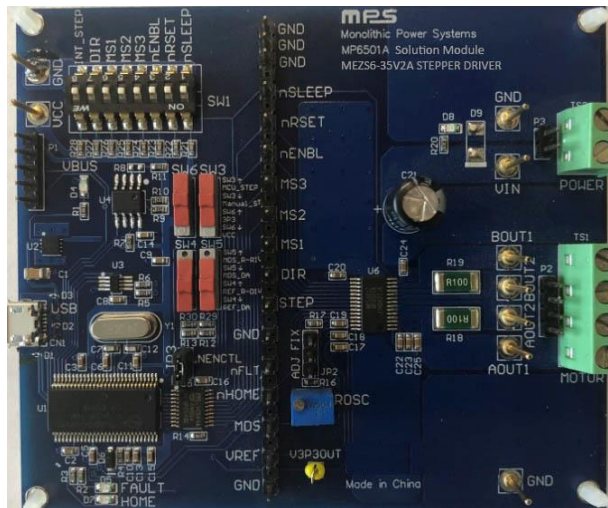

(LxWxH) 10cmx8.5cmx2.5cm

Board Number	MPS IC Number
MEZS6-35V2A Stepper Driver	MP6501AGF

QUICK START GUIDE

Each pin is labeled on the MEZS6-35V2AStepperDriver board. Follow the steps below to use the board:

1. Apply the input power supply ($8V \leq V_{IN} \leq 35V$) and the input ground for the MP6501A to the terminal block TS2 or the connector (P3).
2. Connect the armature windings of the stepper motor to the terminal block (TS1) or the connector (P2).
3. To control the MP6501A using DIP switch SW1:
 - a. Remove the short jumper from JP3 to disable the chip (U5).
 - b. Apply the VCC voltage (3.3V or 5V) to the VCC connector.
 - c. Slide SW3 to the bottom side to select manual step.
 - d. Slide SW4 to the top side to select a fixed voltage for the VREF input.
 - e. Slide SW5 to the top side to select a fixed voltage for the MDS input.
 - f. Slide SW6 to the bottom side to select the VCC voltage as a pull-up supply.
4. To control the MP6501A using the on-board USB microcontroller and GUI:
 - a. Place a short jumper on JP3 to enable the chip (U5).
 - b. Set all of the switches on the DIP switch SW1 to “off.”
 - c. Slide SW3 to the top side to select internal MCU step.
 - d. Slide SW4 to the bottom side to select the on-board DAC, which is set by the GUI, for the VREF input.
 - e. Slide SW5 to the bottom side to select the on-board DAC, which is set by the GUI, for the MDS input.
 - f. Slide SW6 to the top side to select the on-board fixed 3.3V voltage as a pull-up supply.
5. To use a fixed off time, set by R17 (196k Ω), place a jumper across the pins labeled “fix” on the header (JP2). To use the trim pot to adjust the off time, place a jumper across the pins labeled “ADJ” on the header (JP2).
6. The LED (D5) indicates the fault status. When an over-temperature protection or over-current protection occurs, nFAULT is pulled down to a low level and lights up the LED.
7. The current-sense resistors (R18 and R19), in conjunction with the voltage applied to the VREF pin, control the current through the MP6501A.

GUI OPERATION

MPS offers a PC-based GUI program that is used to control the MEZS6-35V2AStepperDriver from a Windows PC. This GUI can be downloaded from the MPS website. To use the GUI, follow the steps below:

1. Connect the board to a USB port on the computer.
2. Launch the GUI. It should show selection buttons for three pages (see Figure 1).



Figure 1: Main Page

3. Click the “Monitor” button. Figure 2 shows the screen that will be displayed.

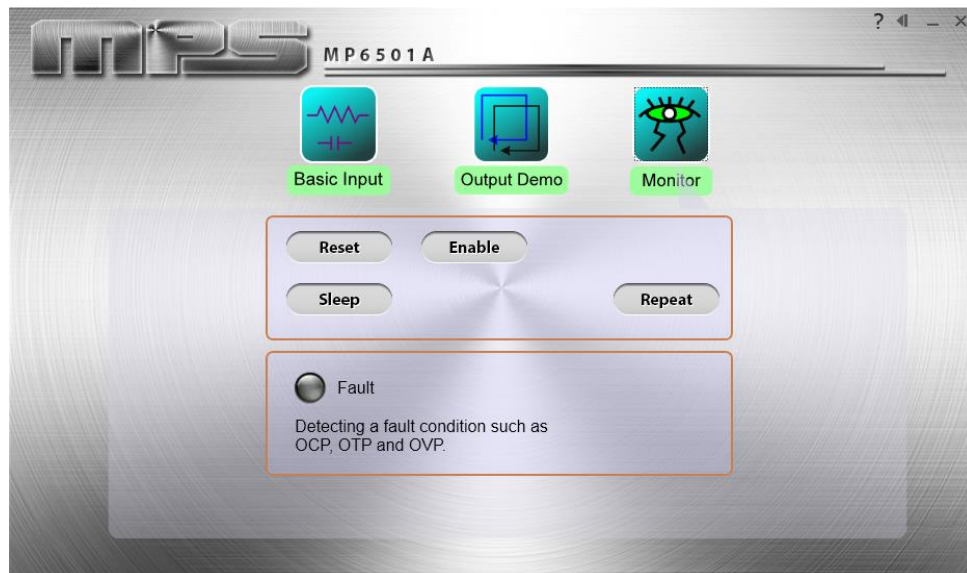

Figure 2: Monitor Page

4. From this screen, a reset pulse can be generated for the MP6501A by clicking the “Reset” button. Enter or exit sleep mode by clicking “Sleep.” Enable or disable the MP6501A by clicking the “Enable” button. Note that the MP6501A must be enabled before trying to move the motor.

- If a fault condition (over temperature, over current, etc.) is encountered, the “Fault” button will illuminate.
- Click the “Basic Input” button. Figure 3 shows the screen below that should be displayed. Step mode (from eighth-step to full-step) and the step direction are now selectable.

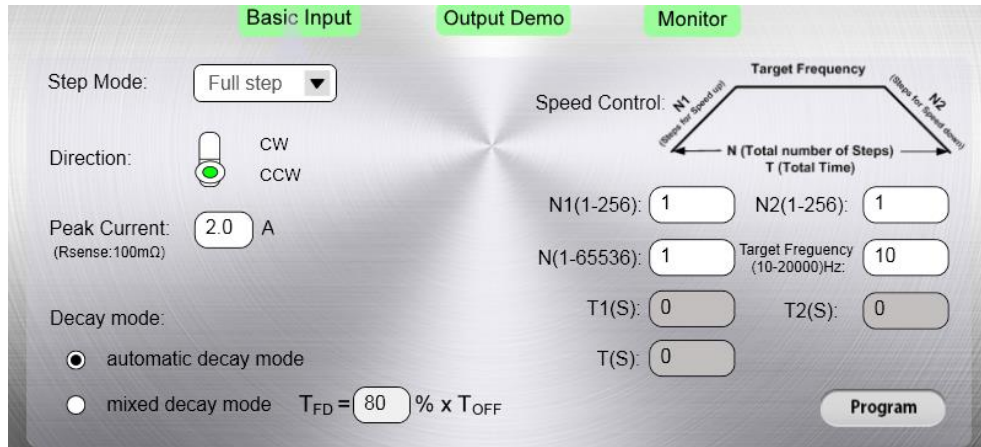

Figure 3: Basic Input Page

- Enter a numeric value in the “Peak Current” box to set the peak winding current (the value assumes a 100mΩ sense resistor, which is normally installed on the board).
- If decay mode is desired, select automatic decay mode or enter a numeric value for the fast decay portion of mixed decay (for slow decay enter “1”; for fast decay, enter “100”).
- The “Speed Control” section allows the user to set a number of steps for ramping up and ramping down, a number of steps to run at the target step rate, and the frequency (step rate) in Hz or PPS. The resulting ramp-up, run, and ramp-down times are then displayed.
- Once these parameters are set, click the “Program” button. The motor will begin moving as programmed.
- Click the “Output Demo” button. Figure 4 shows the screen that should be displayed, which diagrammatically displays the winding currents for the selected decay and step modes.

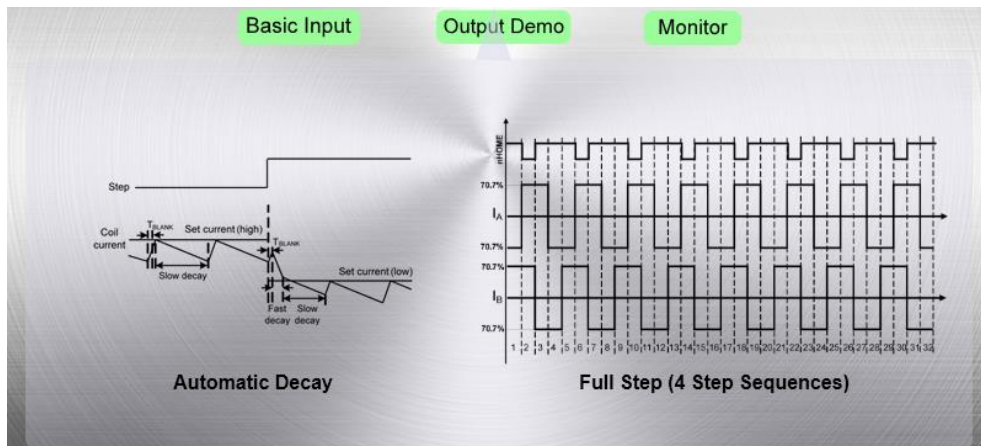
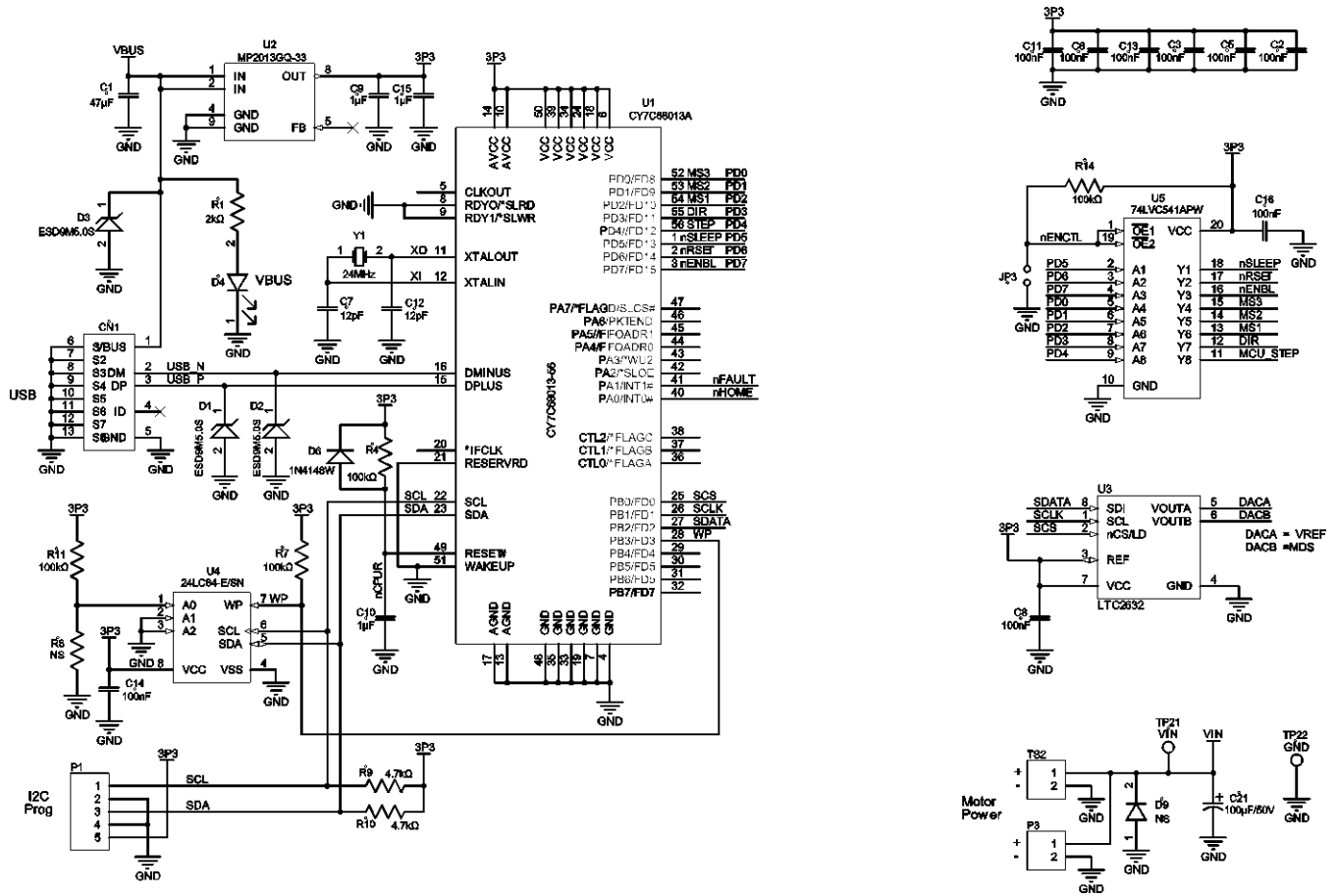

Figure 4: Output Demo Page

SOLUTION KIT SCHEMATIC



SOLUTION KIT SCHEMATIC (continued)

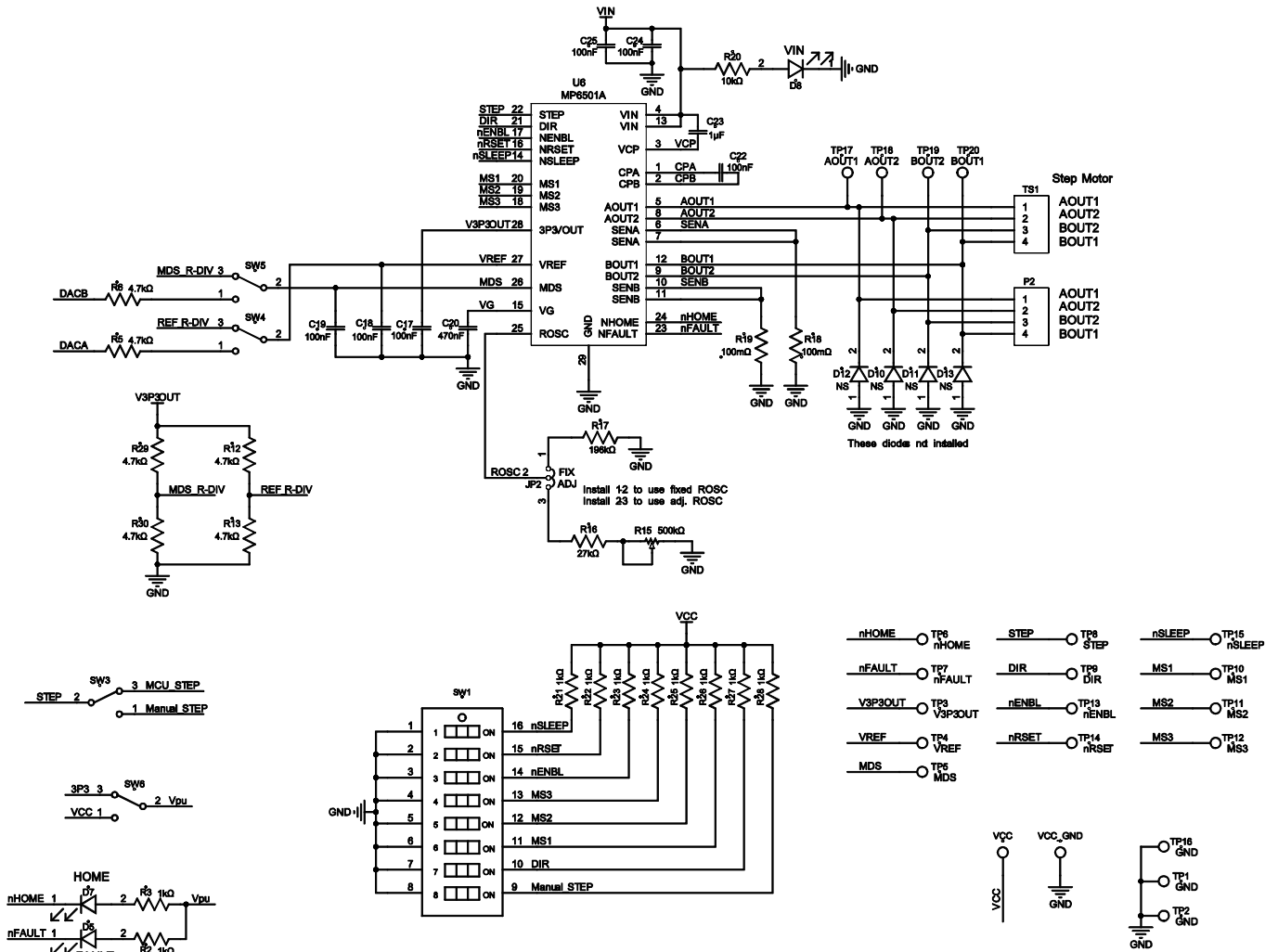

Figure 6: Solution Kit Schematic

MEZS6-35V2ASTEPPERDRIVER BILL OF MATERIALS

Qty	Ref	Value	Description	Package	Manufacturer	Part Number
1	C1	47µF	Ceramic capacitor, 6.3V, X6S	1206	Murata	GRM31CC80J476ME18L
15	C2, C3, C5, C6, C8, C11, C13, C14, C16, C17, C18, C19, C22, C24, C25	100nF	Ceramic capacitor, 50V, X7R	0603	Murata	GRM188R71H104KA93D
2	C7, C12	12pF	Ceramic capacitor, 50V, C0G	0603	Murata	GRM1885C1H120JA01
4	C9, C10, C15, C23	1µF	Ceramic capacitor, 16V, X7R	0603	Murata	GRM188R71C105KA12D
1	C20	470nF	Ceramic capacitor, 16V, X7R	0603	Murata	GRM188R71C474KA88D
1	C21	100µF	Electrolytic capacitor, 50V	DIP	Rubycon	50YXF100MEFC
1	R1	2kΩ	Film resistor, 1%	0603	Yageo	RC0603FR-072KL
10	R2, R3, R21, R22, R23, R24, R25, R26, R27, R28	1kΩ	Film resistor, 1%	0603	Yageo	RC0603FR-071KL
4	R4, R7, R11, R14	100kΩ	Film resistor, 1%	0603	Yageo	RC0603FR-07100KL
8	R5, R6, R9, R10, R12, R13, R29, R30	4.7kΩ	Film resistor, 1%	0603	Yageo	RC0603FR-074K7L
1	R8	NS				
1	R15	500kΩ	Square trimming potentiometer	DIP	Any	3266W-1-504LF
1	R16	27kΩ	Film resistor, 1%	0603	Yageo	RC0603FR-0727KL
1	R17	196kΩ	Film resistor, 1%	0603	Yageo	RC0603FR-07196KL
2	R18, R19	100mΩ	Sense resistor, 1%, 2W	2512	Cyntec	RL-3264-9-R100-FN
1	R20	10kΩ	Film resistor, 1%	0603	Yageo	RC0603FR-0710KL
3	D1, D2, D3		TVS	SOD-923	On Semi	ESD9M5.0S
4	D4, D5, D7, D8	Red	LED	0805	Baihong	BL-HUE35A-AV-TRB
1	D6	0.15A	Diode, 75V, 0.15A	SOD-123	Changdian	1N4148W

MEZS6-35V2ASTEPPERDRIVER BILL OF MATERIALS (continued)

Qty	Ref	Value	Description	Package	Manufacturer	Manufacturer PN
5	D9, D10, D11, D12, D13	NS				
1	U1		USB microcontroller	TSSOP56	Cypress	CY7C68013A-56PVXC
1	U2	MP2013	Low-power linear regulator	QFN-8 (3mmx3mm)	MPS	MP2013GQ-33
1	U3		DAC	8-lead TSOT-23	Analog	LTC2632ACTS8
1	U4		64kbit, 400kHz, 2.5V, I ² C serial EEPROM	SO8	Microchip	24LC64-E/SN
1	U5		Octal buffer and line driver with three state outputs	TSSOP-20	NXP	74LVC541APW
1	U6	MP6501A	Stepper motor driver	TSSOP- 28EP	MPS	MP6501AGF
1	Y1		Crystal oscillator	DIP	Citizen	HC49US-24.000MABJ-UB
1	CN1		Micro-USB	SMD	FCI	10118194-0001LF
1	JP2	3-bits/ 2.54mm	Connector	DIP	Any	61304011121
2	JP3, P3	2-bits/ 2.54mm	Connector	DIP	Any	61304011121
1	P1	5-bits/ 2.54mm	Connector	DIP	Any	61304011121
1	P2	4-bits/ 2.54mm	Connector	DIP	Any	61304011121
1	SW1	8-bits	Button	SMD	Wurth	418121270808
4	SW3, SW4, SW5, SW6	SPDT	Button	DIP	Wurth	450301014042
1	TS1	4 pins	Header	DIP	Phoenix Contact	1729144
1	TS2	2 pins	Header	DIP	Phoenix Contact	1729128
9	VCC, VCC_GND, VIN, VIN_GND, AOUT1, AOUT2, BOUT1, BOUT2, GND	Φ=1mm	Connector	DIP	Any	Φ=1mm Needle
1	V3P3OUT	Yellow	Test point	DIP	Any	Test point
1	Other test points	31-bits/ 2.54mm	Connector	DIP	Any	61304011121

PCB LAYOUT

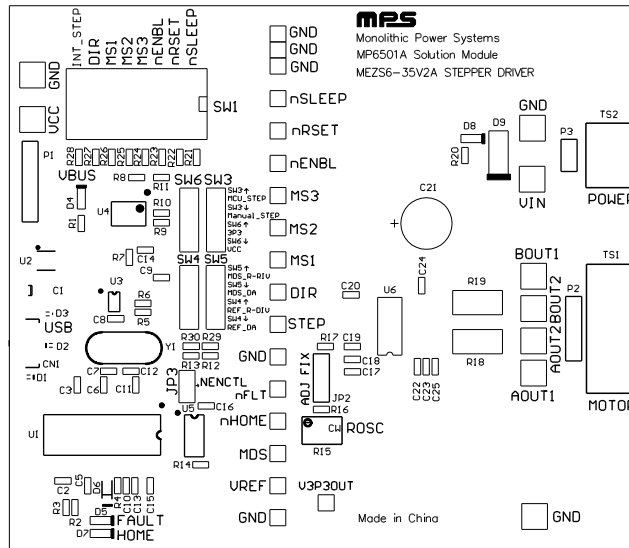

Figure 7: Top Silk Layer

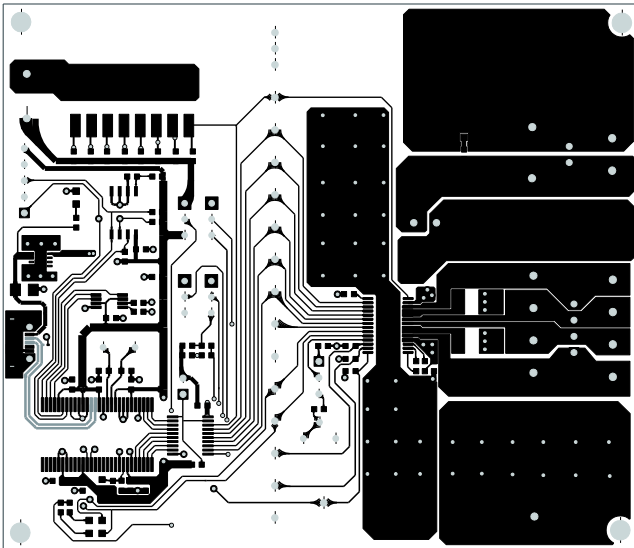

Figure 8: Top Layer

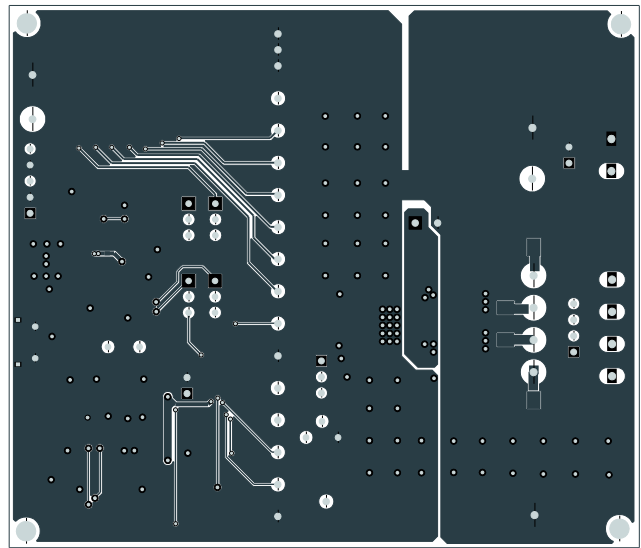

Figure 9: Bottom Layer