



## Features

- Radial leaded devices
- Cured, flame retardant epoxy polymer insulating material meets UL 94V-0 requirements
- Bulk packaging, tape and reel available
- Resettable circuit protection
- Agency recognition:  
- RoHS compliant\* and halogen free\*\*

## Applications

- Food blenders, coffee machines
- HVAC
- Electric fans, blowers
- AC adaptors

# MF-RM Series - Line Voltage PTC Resettable Fuses

## Electrical Characteristics

Model	Maximum Voltage		Max. Current	$I_{hold}$	$I_{trip}$	Initial Resistance	1 Hour Post-Trip Resistance $R_{1max}$	Max. Time To Trip		Tripped Power Dissipation	Agency Recognition	
	Oper.	Inter.	$I_{max}$	at 23 °C		Min. at 23 °C	Max. at 23 °C	at 23 °C		Typ. at 23 °C	cUL	TÜV
	VAC	VAC	Amps	Amps		Ohms	Ohms	Amps	Seconds	Watts	<a href="#">E174545</a>	<a href="#">50232433</a>
MF-RM005/240	240	265	1.0	0.05	0.12	18.5	65.0	0.25	10.0	0.9	✓	✓
MF-RM008/240	240	265	1.2	0.08	0.19	7.4	26.0	0.40	10.0	0.9	✓	✓
MF-RM012/240	240	265	1.2	0.12	0.30	3.0	12.0	0.60	15.0	1.0	✓	✓
MF-RM016/240	240	265	2.0	0.16	0.37	2.5	7.80	0.80	15.0	1.4	✓	✓
MF-RM025/240	240	265	3.5	0.25	0.56	1.3	3.80	1.25	18.5	1.5	✓	✓
MF-RM033/240	240	265	4.5	0.33	0.74	0.77	2.60	1.65	21.0	1.7	✓	✓
MF-RM040/240	240	265	5.5	0.40	0.90	0.60	1.90	2.00	24.0	2.0	✓	✓
MF-RM055/240	240	265	7.0	0.55	1.25	0.45	1.45	2.75	26.0	3.4	✓	✓

## Environmental Characteristics

Item	Condition	Criteria
Operating Temperature	-20 °C to +85 °C	
Recommended Storage	+40 °C max. / 70 % R.H. max.	
Passive Aging	+85 °C, 1000 hours	±20 % typical resistance change
Humidity Aging	+85 °C, 85 % R.H. 1000 hours	±20 % typical resistance change
Thermal Shock	-40 °C to +85 °C, 10 times	±15 % typical resistance change
Solvent Resistance	MIL-STD-202, Method 215	No change (marking still legible)
Vibration	MIL-STD-883C, Method 2007.1 Condition A	No change ( $R_{min} \leq R \leq R_{1max}$ )
Moisture Sensitivity Level (MSL)	<a href="#">See Note</a>	
ESD Classification	Class 6 (per AEC-Q200-2, HBM)	

## Additional Information

Click these links for more information:



[PRODUCT SELECTOR](#) [TECHNICAL LIBRARY](#) [INVENTORY](#) [SAMPLES](#) [CONTACT](#)



**WARNING**  
Cancer and Reproductive Harm  
[www.P65Warnings.ca.gov](http://www.P65Warnings.ca.gov)

\* RoHS Directive 2015/863, Mar 31, 2015 and Annex.

\*\* Bourns considers a product to be "halogen free" if (a) the Bromine (Br) content is 900 ppm or less; (b) the Chlorine (Cl) content is 900 ppm or less; and (c) the total Bromine (Br) and Chlorine (Cl) content is 1500 ppm or less.

Specifications are subject to change without notice. Users should verify actual device performance in their specific applications. The products described herein and this document are subject to specific legal disclaimers as set forth on the last page of this document, and at [www.bourns.com/docs/legal/disclaimer.pdf](http://www.bourns.com/docs/legal/disclaimer.pdf).

## Advantages

- Resettable feature with overtemperature and overcurrent protection can save expensive components from having to be replaced after tripping, e.g., transformers with built in thermal fuses
- Faster than bimetallic switch designs that take on average approximately 30 seconds to cool down and reset
- Generally lower electromagnetic interference than bimetallic switches

## Benefits

- Reduced repair and replacement costs
- Reduced nuisance tripping
- Combined overcurrent and overtemperature protector in one device

# MF-RM Series - Line Voltage PTC Resettable Fuses

# BOURNS®

### Test Procedures and Requirements

Item	Test Conditions	Accept/Reject Criteria
Visual/Mechanical	Verify dimensions and materials	Per MF physical description
Resistance	In still air @ 23 °C	$R_{min} \leq R \leq R_{max}$
Time to Trip	At specified current, $V_{max}$ , 23 °C, still air	$T \leq \text{max. time to trip (seconds)}$
Hold Current	30 min. at $I_{hold}$ , still air	No trip
Trip Cycle Life	Operating voltage, $I_{max}$ , 100 cycles	No arcing or burning
Trip Endurance A	Operating voltage, $I_{max}$ , 24 hours	No arcing or burning
Trip Endurance B	Interrupt voltage, $I_{max}$ , 30 minutes	No arcing or burning
Solderability	245 °C ± 5 °C, 5 seconds	95 % min. coverage

### Thermal Derating Table - $I_{hold}$ (Amps)

Model	Ambient Operating Temperature							
	-20 °C	0 °C	23 °C	40 °C	50 °C	60 °C	70 °C	85 °C
MF-RM005/240	0.08	0.06	0.05	0.04	0.04	0.03	0.03	0.02
MF-RM008/240	0.12	0.10	0.08	0.07	0.06	0.05	0.04	0.03
MF-RM012/240	0.18	0.15	0.12	0.10	0.09	0.07	0.06	0.04
MF-RM016/240	0.24	0.20	0.16	0.13	0.11	0.10	0.08	0.05
MF-RM025/240	0.38	0.32	0.25	0.21	0.18	0.15	0.13	0.09
MF-RM033/240	0.50	0.42	0.33	0.27	0.23	0.20	0.17	0.11
MF-RM040/240	0.61	0.51	0.40	0.33	0.28	0.24	0.20	0.14
MF-RM055/240	0.80	0.68	0.55	0.46	0.40	0.35	0.29	0.22

### Typical Time to Trip at 23 °C

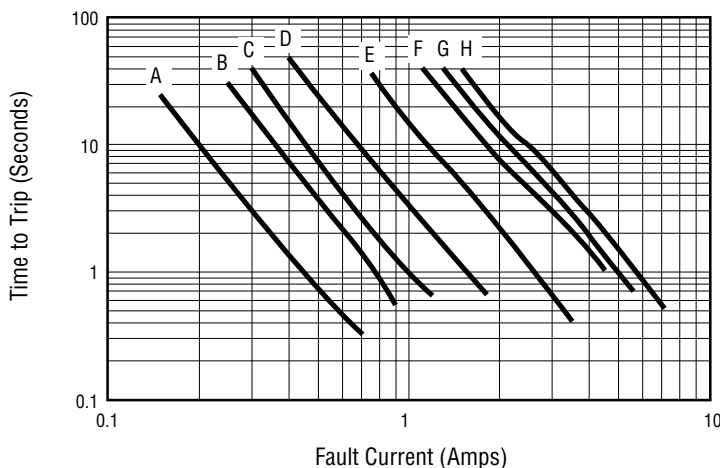

- A = MF-RM005/240
- B = MF-RM008/240
- C = MF-RM012/240
- D = MF-RM016/240
- E = MF-RM025/240
- F = MF-RM033/240
- G = MF-RM040/240
- H = MF-RM055/240

### How to Order

**MF - RM 005 / 240 - 2 - 17**

Multifuse®  
 Product Designator \_\_\_\_\_  
 Series \_\_\_\_\_  
 RM = Radial Ledged Line Voltage Component  
 Hold Current,  $I_{hold}$  \_\_\_\_\_  
 005-055 (0.05 A - 0.55 A)  
 Operating Voltage,  $V_{max}$  \_\_\_\_\_  
 240 = 240 Vac  
 Packaging Options \_\_\_\_\_  
 - 0 = Bulk Packaging  
 - 2 = Tape and Reel per EIA-468  
 Part Number Suffix Option \_\_\_\_\_  
 - 17 = Straight Leads where Kinked Leads are Standard

The Time to Trip curves represent typical performance of a device in a simulated application environment. Actual performance in specific customer applications may differ from these values due to the influence of other variables.

Specifications are subject to change without notice.

Users should verify actual device performance in their specific applications.

The products described herein and this document are subject to specific legal disclaimers as set forth on the last page of this document, and at [www.bourns.com/docs/legal/disclaimer.pdf](http://www.bourns.com/docs/legal/disclaimer.pdf).

# MF-RM Series - Line Voltage PTC Resettable Fuses



## Product Dimensions

Model	A Max.	B Max.	C		D Min.	E Max.	Physical Characteristics		
			Nom.	Tol. ±			Style	Lead Dia.	Material
MF-RM005/240	$\frac{8.3}{(0.327)}$	$\frac{12.9}{(0.508)}$	$\frac{5.1}{(0.201)}$	$\frac{0.7}{(0.028)}$	$\frac{7.6}{(0.299)}$	$\frac{3.8}{(0.150)}$	1	$\frac{0.51}{(0.020)}$	Sn/Cu
MF-RM008/240	$\frac{8.3}{(0.327)}$	$\frac{12.9}{(0.508)}$	$\frac{5.1}{(0.201)}$	$\frac{0.7}{(0.028)}$	$\frac{7.6}{(0.299)}$	$\frac{3.8}{(0.150)}$	1	$\frac{0.51}{(0.020)}$	Sn/Cu
MF-RM012/240	$\frac{8.3}{(0.327)}$	$\frac{12.9}{(0.508)}$	$\frac{5.1}{(0.201)}$	$\frac{0.7}{(0.028)}$	$\frac{7.6}{(0.299)}$	$\frac{3.8}{(0.150)}$	1	$\frac{0.51}{(0.020)}$	Sn/Cu
MF-RM016/240	$\frac{9.9}{(0.390)}$	$\frac{13.8}{(0.543)}$	$\frac{5.1}{(0.201)}$	$\frac{0.7}{(0.028)}$	$\frac{7.6}{(0.299)}$	$\frac{3.8}{(0.150)}$	1	$\frac{0.51}{(0.020)}$	Sn/Cu
MF-RM025/240	$\frac{10.0}{(0.394)}$	$\frac{20.0}{(0.787)}$	$\frac{5.1}{(0.201)}$	$\frac{0.7}{(0.028)}$	$\frac{7.6}{(0.299)}$	$\frac{3.8}{(0.150)}$	2	$\frac{0.65}{(0.026)}$	Sn/Cu
MF-RM033/240	$\frac{11.4}{(0.449)}$	$\frac{20.0}{(0.787)}$	$\frac{5.1}{(0.201)}$	$\frac{0.7}{(0.028)}$	$\frac{7.6}{(0.299)}$	$\frac{3.8}{(0.150)}$	2	$\frac{0.65}{(0.026)}$	Sn/Cu
MF-RM040/240	$\frac{11.5}{(0.453)}$	$\frac{20.9}{(0.823)}$	$\frac{5.1}{(0.201)}$	$\frac{0.7}{(0.028)}$	$\frac{7.6}{(0.299)}$	$\frac{3.8}{(0.150)}$	2	$\frac{0.65}{(0.026)}$	Sn/Cu
MF-RM055/240	$\frac{14.0}{(0.551)}$	$\frac{22.4}{(0.882)}$	$\frac{5.1}{(0.201)}$	$\frac{0.7}{(0.028)}$	$\frac{7.6}{(0.299)}$	$\frac{4.1}{(0.161)}$	2	$\frac{0.81}{(0.032)}$	Sn/Cu

DIMENSIONS:  $\frac{MM}{(INCHES)}$

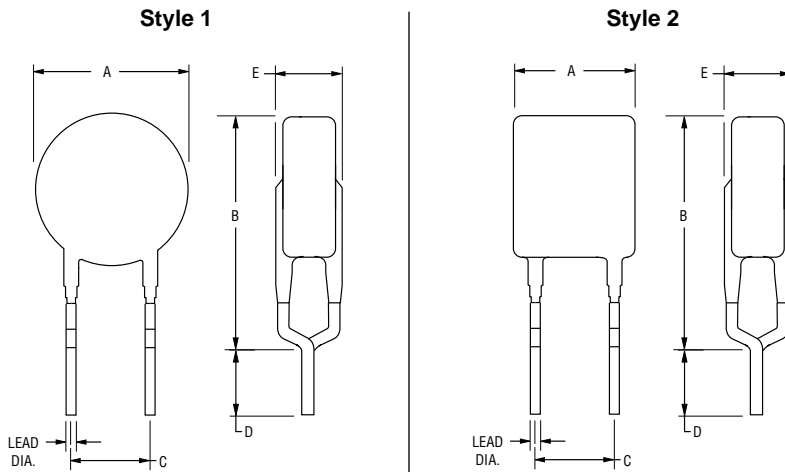

Also available with straight leads (see How to Order).

## Typical Part Marking

Represents total content. Layout may vary.

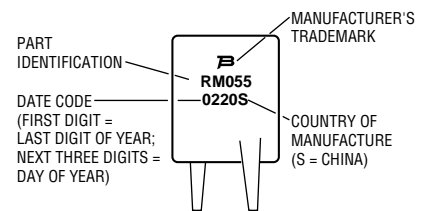

## Packaging Quantity

Packaging options	Models	Unit Quantity (Pcs.)	Unit
Bulk	All models	500	Bag
Tape & Reel	MF-RM005/240 ~ MF-RM040/240	2000	Reel
	MF-RM055/240	1000	

Specifications are subject to change without notice.

Users should verify actual device performance in their specific applications.

The products described herein and this document are subject to specific legal disclaimers as set forth on the last page of this document, and at [www.bourns.com/docs/legal/disclaimer.pdf](http://www.bourns.com/docs/legal/disclaimer.pdf).

# MF-RM Series Tape and Reel Specifications

**BOURNS®**

Devices taped using EIA-468/IEC 60286-2 standards. See table below and figures for details.

Dimension Description	IEC Mark	EIA Mark	Dimensions	Tolerance
Carrier tape width	$W$	$W$	$\frac{18}{(.709)}$	$\frac{+1.0/-0.5}{(+.039/- .020)}$
Hold down tape width	$W_0$	$W_0$	$\frac{5}{(.197)}$	min.
Hold down tape	No protrusion			
Adhesive tape position	$W_2$	$W_2$	$\frac{3}{(.118)}$	max.
Sprocket hole position	$W_1$	$W_1$	$\frac{9}{(.354)}$	$\frac{+0.75/-0.5}{(+.030/- .020)}$
Sprocket hole diameter	$D_0$	$D_0$	$\frac{4}{(.157)}$	$\frac{+0.2}{(\pm.0078)}$
Height to seating plane (straight lead)	$H$	$H$	$\frac{18 \sim 20}{(.709 \sim .787)}$	
Height to seating plane (formed lead)	$H_0$	$H_0$	$\frac{16}{(.630)}$	$\frac{+0.5}{(\pm.020)}$
Overall height above abscissa: MF-RM005/240 ~ RM016/240	$H_1$	$H_1$	$\frac{38.5}{(1.516)}$	max.
Overall height above abscissa: MF-RM025/240 ~ RM055/240	$H_1$	$H_1$	$\frac{48.0}{(1.890)}$	max.
Cutout length		$L$	$\frac{11}{(.433)}$	max.
Sprocket hole pitch	$P_0$	$P_0$	$\frac{12.7}{(.500)}$	$\frac{+0.3}{(\pm.012)}$
Device pitch: MF-RM005/240 ~ MF-RM040/240	$P$	$P$	$\frac{12.7}{(.500)}$	$\frac{+0.3}{(\pm.012)}$
Device pitch: MF-RM055/240	$P$	$P$	$\frac{25.4}{(1.00)}$	$\frac{+0.3}{(\pm.012)}$
Pitch tolerance			20 consecutive	$\frac{\pm 1}{(\pm.039)}$
Composite tape thickness	$t$	$t$	$\frac{0.9}{(.035)}$	max.
Overall tape and lead thickness: MF-RM005/240 ~ MF-RM040/240	$t_1$	$t_1$	$\frac{2.0}{(.079)}$	max.
Overall tape and lead thickness: MF-RM055/240	$t_1$	$t_1$	$\frac{2.3}{(.091)}$	max.
Splice sprocket hole alignment			0	$\frac{+0.3}{(\pm.012)}$
Front-to-back deviation	$\Delta_h$	$\Delta_h$	0	$\frac{+1.0}{(\pm.039)}$
Side-to-side deviation	$\Delta_p$	$\Delta_p$	0	$\frac{+1.3}{(\pm.051)}$
Ordinate to adjacent component lead	$P_1$	$P_1$	$\frac{3.81}{(.150)}$	$\frac{+0.7}{(\pm.028)}$
Lead spacing	$F$	$F$	$\frac{5.08}{(.200)}$	$\frac{+0.6/-0.2}{(+.024/- .008)}$

— Continued on next page —

DIMENSIONS:  $\frac{\text{MM}}{\text{(INCHES)}}$

Specifications are subject to change without notice.

Users should verify actual device performance in their specific applications.

The products described herein and this document are subject to specific legal disclaimers as set forth on the last page of this document, and at [www.bourns.com/docs/legal/disclaimer.pdf](http://www.bourns.com/docs/legal/disclaimer.pdf).

# MF-RM Series Tape and Reel Specifications

# BOURNS®

Devices taped using EIA-468/IEC 60286-2 standards. See table below and figures for details.

Dimension Description	IEC Mark	EIA Mark	Dimensions	Tolerance
Reel width including flanges and hub	$W_4$	$w_2$	$\frac{62.0}{(2.44)}$	max
Dimension between flanges (measured at hub)	$W_3$	$w_1$	allow proper reeling and unreeling	
Reel diameter	A	a	$\frac{370.0}{(14.57)}$	max.
Space between flanges (at hub, excluding device)			$\frac{4.75}{(.187)}$	$\pm 3.25$ ( $\pm .128$ )
Arbor hole diameter	C	c	$\frac{26.0}{(1.024)}$	$\pm 12.0$ ( $\pm .472$ )
Core diameter	N	n	$\frac{80}{(3.15)}$	min.
Box dimensions			$\frac{62 \times 372 \times 372}{(2.44 \times 14.6 \times 14.6)}$	max.
Consecutive missing places			3	max.
Empty places per reel			Less than 0.1 %	

**Taped Component Dimensions - per EIA Mark - Figure 1**

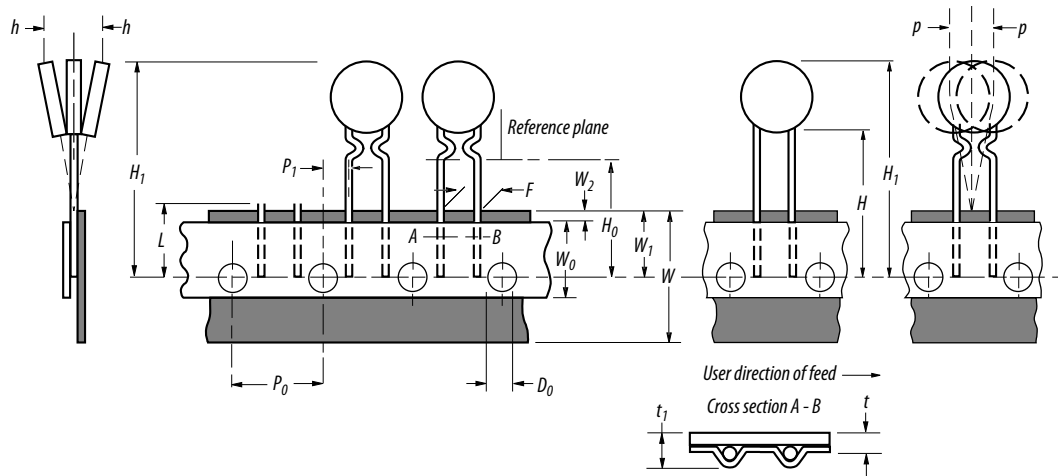

**Reel Dimensions - per EIA Mark - Figure 2**

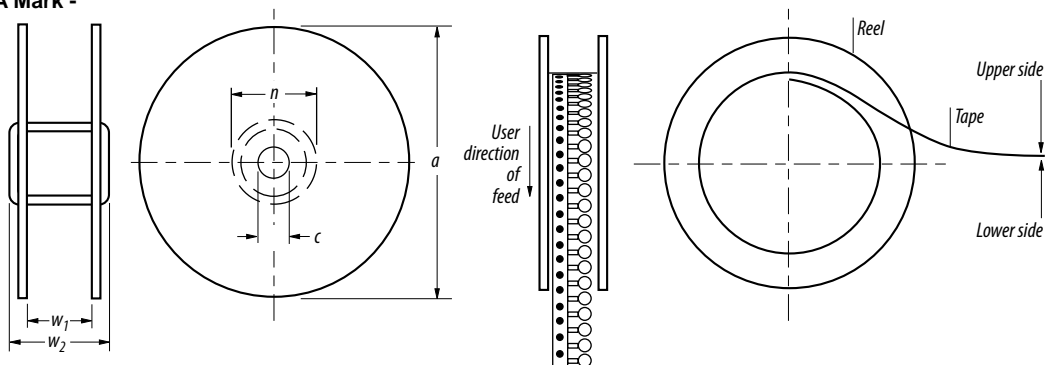

MF-RM SERIES, REV. G, 05/21

Specifications are subject to change without notice.

Users should verify actual device performance in their specific applications.

The products described herein and this document are subject to specific legal disclaimers as set forth on the last page of this document, and at [www.bourns.com/docs/legal/disclaimer.pdf](http://www.bourns.com/docs/legal/disclaimer.pdf).

**Application Notice**

- Users are responsible for independent and adequate evaluation of Bourns® Multifuse® Polymer PTC devices in the user's application, including the PPTC device characteristics stated in the applicable data sheet.
- Polymer PTC devices must not be allowed to operate beyond their stated maximum ratings. Operation in excess of such maximum ratings could result in damage to the PTC device and possibly lead to electrical arcing and/or fire. Circuits with inductance may generate a voltage above the rated voltage of the polymer PTC device and should be thoroughly evaluated within the user's application during the PTC selection and qualification process.
- Polymer PTC devices are intended to protect against adverse effects of temporary overcurrent or overtemperature conditions up to rated limits and are not intended to serve as protective devices where overcurrent or overvoltage conditions are expected to be repetitive or prolonged.
- In normal operation, polymer PTC devices experience thermal expansion under fault conditions. Thus, a polymer PTC device must be protected against mechanical stress, and must be given adequate clearance within the user's application to accommodate such thermal expansion. Rigid potting materials or fixed housings or coverings that do not provide adequate clearance should be thoroughly examined and tested by the user, as they may result in the malfunction of polymer PTC devices if the thermal expansion is inhibited.
- Exposure to lubricants, silicon-based oils, solvents, gels, electrolytes, acids, and other related or similar materials may adversely affect the performance of polymer PTC devices.
- Aggressive solvents may adversely affect the performance of polymer PTC devices. Conformal coating, encapsulating, potting, molding, and sealing materials may contain aggressive solvents including but not limited to xylene and toluene, which are known to cause adverse effects on the performance of polymer PTCs. Such aggressive solvents must be thoroughly cured or baked to ensure their complete removal from polymer PTCs to minimize the possible adverse effect on the device.
- Recommended storage conditions should be followed at all times. Such conditions can be found on the applicable data sheet and on the Multifuse® Polymer PTC Moisture/Reflow Sensitivity Classification (MSL) note:  
[https://www.bourns.com/docs/RoHS-MSL/msl\\_mf.pdf](https://www.bourns.com/docs/RoHS-MSL/msl_mf.pdf)