



Features

- Radial leaded devices
- Fast trip resettable PTCs
- Binned and sorted narrow resistance ranges available
- RoHS compliant*
- Agency recognition: 

Applications

- Customer Premise Equipment (CPE)
- Central Office / Telecom Centers (CO)
- Access equipment

MF-RX/250 Series - Telecom PTC Resettable Fuses

Electrical Characteristics

Model	Maximum Operating Voltage (DC)	Maximum Interrupt Ratings		I _{hold}	I _{trip}	Initial Resistance		One Hour (R ₁) Post-Trip Resistance	Maximum Time to Trip		Tripped Power Dissipation	Agency Recognition	
		Vrms	Amps			at 23 °C			at 23 °C Ohms			at 23 °C	
		Volts	Max.	Max.	Amps	Min.	Max.	Max.	Amps	Sec.	Max.	E174545	R.50260658
MF-RX012/250	60	250	3	0.12	0.24	4.0	8.0	16.0	1.0	2.5	1.0	✓	✓
MF-RX012/250-A	60	250	3	0.12	0.24	7.0	9.0	16.0	1.0	2.5	1.0	✓	✓
MF-RX012/250-C	60	250	3	0.12	0.24	5.5	7.5	14.0	1.0	2.5	1.0	✓	✓
MF-RX012/250-F	60	250	3	0.12	0.24	6.0	10.5	16.0	1.0	2.5	1.0	✓	✓
MF-RX012/250-G	60	250	3	0.12	0.24	5.5	6.5	16.0	1.0	2.5	1.0	✓	✓
MF-RX012/250-H	60	250	3	0.12	0.24	9.0	10.5	16.0	1.0	2.5	1.0	✓	✓
MF-RX012/250-T	60	250	3	0.12	0.24	7.0	12.0	16.0	1.0	2.5	1.0	✓	✓
MF-RX012/250-1	60	250	3	0.12	0.24	6.0	9.0	16.0	1.0	2.5	1.0	✓	✓
MF-RX012/250-2	60	250	3	0.12	0.24	8.0	10.5	16.0	1.0	2.5	1.0	✓	✓
MF-RX012/250U	60	250	3	0.12	0.24	6.0	10.0	16.0	1.0	2.5	1.0	✓	✓
MF-RX014/250	60	250	3	0.145	0.28	3.0	6.0	14.0	1.0	5.0	1.0	✓	✓
MF-RX014/250-A	60	250	3	0.145	0.28	3.0	5.5	12.0	1.0	5.0	1.0	✓	✓
MF-RX014/250-B	60	250	3	0.145	0.28	4.5	6.0	14.0	1.0	5.0	1.0	✓	✓
MF-RX014/250-C	60	250	3	0.145	0.28	3.0	4.0	14.0	1.0	5.0	1.0	✓	✓
MF-RX014/250-T	60	250	3	0.145	0.28	5.4	7.5	14.0	1.0	5.0	1.0	✓	✓
MF-RX014/250U	60	250	3	0.145	0.28	3.5	6.5	12.0	1.0	4.0	1.0	✓	✓
MF-RX018/250	60	250	10	0.18	0.50	0.8	2.0	4.0	1.0	20	1.0	✓	✓
MF-RX018/250U	60	250	10	0.18	0.50	0.8	2.0	4.0	1.0	20	1.0	✓	✓

*"U" suffix indicates product without insulation coating.

Environmental Characteristics

Item	Condition	Criteria
Operating Temperature	-40 °C to +85 °C	
Recommended Storage	+40 °C max. / 70 % R.H. max.	
Passive Aging	+85 °C, 1000 hours	±15 % typical resistance change
Humidity Aging	+85 °C, 85 % R.H. 1000 hours	±15 % typical resistance change
Thermal Shock	-55 °C to +125 °C, 10 times	±15 % typical resistance change
Solvent Resistance	MIL-STD-202, Method 215	No change (marking still legible)
Vibration	MIL-STD-883C, Method 2007.1 Condition A	±15 % typical resistance change
Moisture Sensitivity Level (MSL)	See Note	
ESD Classification	Class 6 (per AEC-Q200-2, HBM)	

Additional Information

Click these links for more information:



[PRODUCT SELECTOR](#) [TECHNICAL LIBRARY](#) [INVENTORY](#) [SAMPLES](#) [CONTACT](#)

BOURNS®

Asia-Pacific: Tel: +886-2 2562-4117

Email: asiacus@bourns.com

EMEA: Tel: +36 88 885 877

Email: eurocus@bourns.com

The Americas: Tel: +1-951 781-5500

Email: americus@bourns.com

www.bourns.com



WARNING
Cancer and Reproductive Harm
www.P65Warnings.ca.gov

* RoHS Directive 2015/863, Mar 31, 2015 and Annex. Specifications are subject to change without notice. Users should verify actual device performance in their specific applications. The products described herein and this document are subject to specific legal disclaimers as set forth on the last page of this document, and at www.bourns.com/docs/legal/disclaimer.pdf.

Additional Features

- Ability to withstand AC power cross conditions
- Assists equipment with meeting ITU-T K.20/K.21/K.45
- Assists equipment with meeting Telcordia GR-1089-C Intrabuilding

MF-RX/250 Series - Telecom PTC Resettable Fuses

BOURNS®

Test Procedures and Requirements

Item	Test Condition	Accept/Reject Criteria
Visual/Mechanical	Verify dimensions and materials	Per MF physical description
Resistance	In still air @ 23 °C	$R_{min} \leq R \leq R_{max}$
Time to Trip	At specified current, V_{max} , 23 °C, still air	$T \leq$ max. time to trip (seconds)
Hold Current	30 min. at I_{hold} , still air	No trip
Trip Cycle Life	V_{max} , I_{max} , 100 cycles	No arcing or burning
Trip Endurance	V_{max} , 48 hours	No arcing or burning
Solderability	245 °C \pm 5 °C, 5 seconds	95 % min. coverage

Thermal Derating Chart - I_{hold} (Amps)

Model	Ambient Operating Temperature								
	-40 °C	-20 °C	0 °C	23 °C	40 °C	50 °C	60 °C	70 °C	85 °C
MF-RX012/250	0.186	0.165	0.143	0.120	0.099	0.088	0.077	0.066	0.050
MF-RX012/250-A	0.186	0.165	0.143	0.120	0.099	0.088	0.077	0.066	0.050
MF-RX012/250-C	0.186	0.165	0.143	0.120	0.099	0.088	0.077	0.066	0.050
MF-RX012/250-F	0.186	0.165	0.143	0.120	0.099	0.088	0.077	0.066	0.050
MF-RX012/250-G	0.186	0.165	0.143	0.120	0.099	0.088	0.077	0.066	0.050
MF-RX012/250-H	0.186	0.165	0.143	0.120	0.099	0.088	0.077	0.066	0.050
MF-RX012/250-T	0.186	0.165	0.143	0.120	0.099	0.088	0.077	0.066	0.050
MF-RX012/250-1	0.186	0.165	0.143	0.120	0.099	0.088	0.077	0.066	0.050
MF-RX012/250-2	0.186	0.165	0.143	0.120	0.099	0.088	0.077	0.066	0.050
MF-RX012/250U	0.186	0.165	0.143	0.120	0.099	0.088	0.077	0.066	0.050
MF-RX014/250	0.225	0.199	0.172	0.145	0.119	0.106	0.093	0.080	0.060
MF-RX014/250-A	0.225	0.199	0.172	0.145	0.119	0.106	0.093	0.080	0.060
MF-RX014/250-B	0.225	0.199	0.172	0.145	0.119	0.106	0.093	0.080	0.060
MF-RX014/250-C	0.225	0.199	0.172	0.145	0.119	0.106	0.093	0.080	0.060
MF-RX014/250-T	0.225	0.199	0.172	0.145	0.119	0.106	0.093	0.080	0.060
MF-RX014/250U	0.225	0.199	0.172	0.145	0.119	0.106	0.093	0.080	0.060
MF-RX018/250	0.269	0.240	0.211	0.180	0.153	0.138	0.123	0.109	0.087
MF-RX018/250U	0.269	0.240	0.211	0.180	0.153	0.138	0.123	0.109	0.087

I_{trip} is approximately two times I_{hold} .

Specifications are subject to change without notice.

Users should verify actual device performance in their specific applications.

The products described herein and this document are subject to specific legal disclaimers as set forth on the last page of this document, and at www.bourns.com/docs/legal/disclaimer.pdf.

MF-RX/250 Series - Telecom PTC Resettable Fuses



Product Dimensions

Model	A	B	C	D	E	Physical Characteristics		
	Max.	Max.	Nom.	Min.	Max.	Lead Dia.	Style	Material
MF-RX012/250	6.5 (0.256)	11.0 (0.433)	5.1 ± 0.7 (0.201 ± 0.028)	4.7 (0.185)	4.6 (0.181)	0.65 (0.026)	1	Sn/Cu
MF-RX012/250-A								
MF-RX012/250-C								
MF-RX012/250-F								
MF-RX012/250-G								
MF-RX012/250-H								
MF-RX012/250-T								
MF-RX012/250-1								
MF-RX012/250-2								
MF-RX012/250U	6.0 (0.236)	10.0 (0.394)	5.1 ± 0.7 (0.201 ± 0.028)	4.7 (0.185)	3.8 (0.150)	0.65 (0.026)	2	Sn/Cu
MF-RX014/250	6.5 (0.256)	11.0 (0.433)	5.1 ± 0.7 (0.201 ± 0.028)	4.7 (0.185)	4.6 (0.181)	0.65 (0.026)	1	Sn/Cu
MF-RX014/250-A								
MF-RX014/250-B								
MF-RX014/250-C								
MF-RX014/250-T								
MF-RX014/250U	6.0 (0.236)	10.0 (0.394)	5.1 ± 0.7 (0.201 ± 0.028)	4.7 (0.185)	3.8 (0.150)	0.65 (0.026)	2	Sn/Cu
MF-RX018/250	11.0 (0.433)	13.6 (0.535)	5.1 ± 0.7 (0.201 ± 0.028)	4.7 (0.185)	4.6 (0.181)	0.65 (0.026)	1	Sn/Cu
MF-RX018/250U	10.4 (0.409)	12.6 (0.496)	5.1 ± 0.7 (0.201 ± 0.028)	4.7 (0.185)	3.8 (0.150)	0.65 (0.026)	2	Sn/Cu

DIMENSIONS: $\frac{\text{MM}}{\text{(INCHES)}}$

Style 1

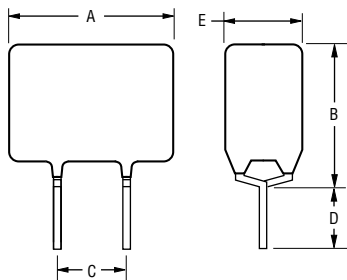

Style 2

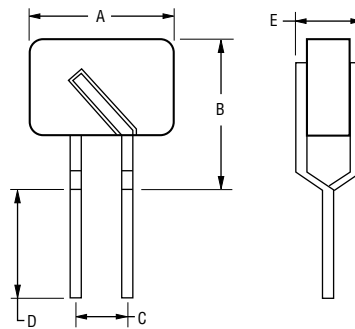

Typical Part Marking

Represents total content. Layout may vary.

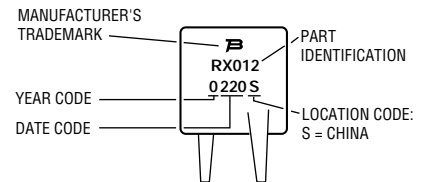

Packaging Quantity

Packaging Options	Models	Unit Quantity (Pcs.)	Unit	Notes
Bulk	All models	500	Bag	
Tape & Reel	All models	1500	Reel	Available Binned

Specifications are subject to change without notice.

Users should verify actual device performance in their specific applications.

The products described herein and this document are subject to specific legal disclaimers as set forth on the last page of this document, and at www.bourns.com/docs/legal/disclaimer.pdf.

MF-RX/250 Series - Telecom PTC Resettable Fuses



How to Order

MF - RX 012/250 U - A 05 - 2

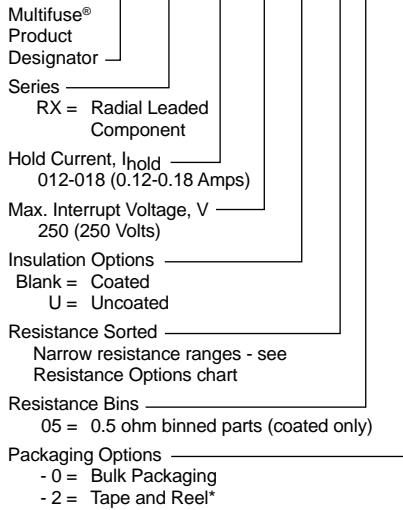

*Packaged per EIA-468

Typical Time to Trip at 23 °C

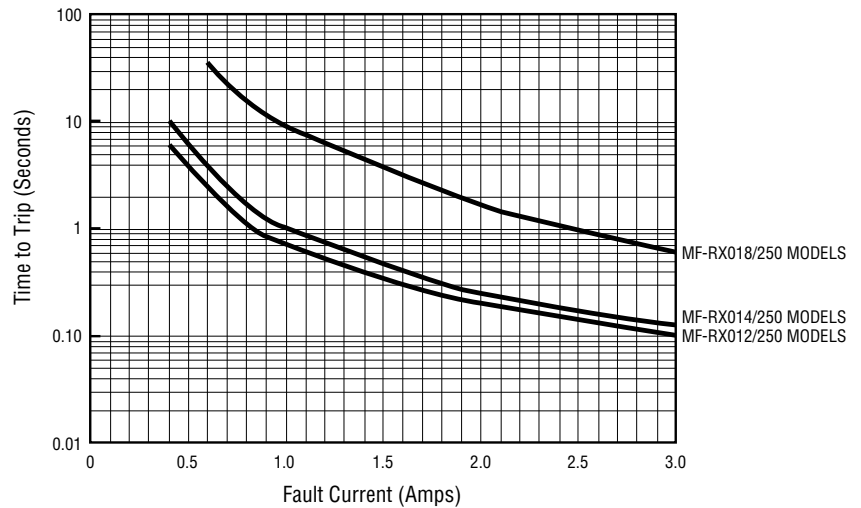

Resistance Options

Model	Initial Resistance Values		R _{1max}	Bin
	Ohms @ 23 °C		Ohms @ 23 °C	
	Min.	Max.	Max.	
MF-RX012/250	4.0	8.0	16.0	N/A
MF-RX012/250-A05	7.0	9.0	16.0	0.5
MF-RX012/250-C05	5.5	7.5	14.0	0.5
MF-RX012/250-F05	6.0	10.5	16.0	0.5
MF-RX012/250-G05	5.5	6.5	16.0	N/A
MF-RX012/250-H05	9.0	10.5	16.0	N/A
MF-RX012/250-T05	7.0	12.0	16.0	0.5
MF-RX012/250-105	6.0	9.0	16.0	0.5
MF-RX012/250-205	8.0	10.5	16.0	0.5
MF-RX012/250U	6.0	10.0	16.0	N/A
MF-RX014/250	3.0	6.0	14.0	N/A
MF-RX014/250-A05	3.0	5.5	12.0	0.5
MF-RX014/250-B05	4.5	6.0	14.0	0.5
MF-RX014/250-C05	3.0	4.0	14.0	N/A
MF-RX014/250-T05	5.4	7.5	14.0	0.5
MF-RX014/250U	3.5	6.5	12.0	N/A
MF-RX018/250	0.8	2.0	4.0	N/A
MF-RX018/250U	0.8	2.0	4.0	N/A

Specifications are subject to change without notice.

Users should verify actual device performance in their specific applications.

The products described herein and this document are subject to specific legal disclaimers as set forth on the last page of this document, and at www.bourns.com/docs/legal/disclaimer.pdf.

MF-RX/250 Series Tape and Reel Specifications

BOURNS®

Devices taped using EIA-468/IEC 60286-2 standards. See table below and figures for details.

Dimension Description	IEC Mark	EIA Mark	Dimensions	
			Dimensions	Tolerance
Carrier tape width	W	W	$\frac{18}{(0.709)}$	$\frac{-0.5/+1.0}{(-0.02/+0.039)}$
Hold down tape width	W_0	W_0	$\frac{5}{(0.197)}$	min.
Hold down tape			No protrusion	
Adhesive tape position	W_2	W_2	$\frac{3}{(0.118)}$	max.
Sprocket hole position	W_1	W_1	$\frac{9}{(0.354)}$	$\frac{-0.5/+0.75}{(-0.02/+0.03)}$
Sprocket hole diameter	D_0	D_0	$\frac{4}{(0.157)}$	$\frac{\pm 0.2}{(\pm 0.0078)}$
Height to seating plane (straight lead)	H	H	$\frac{18 \sim 20}{(0.709 \sim 0.787)}$	
Height to seating plane (formed lead)	H_0	H_0	$\frac{16}{(0.63)}$	$\frac{\pm 0.5}{(\pm 0.2)}$
Overall height above abscissa	H_1	H_1	$\frac{38.5}{(1.516)}$	max.
Cutout Length		L	$\frac{11}{(0.433)}$	max.
Sprocket hole pitch	P_0	P_0	$\frac{12.7}{(0.5)}$	$\frac{\pm 0.3}{(\pm 0.012)}$
Device pitch	P	P	$\frac{12.7}{(0.5)}$	$\frac{\pm 0.3}{(\pm 0.012)}$
Pitch tolerance			20 consecutive	$\frac{\pm 1}{(\pm 0.039)}$
Composite tape thickness	t	t	$\frac{0.9}{(0.035)}$	max.
Overall tape and lead thickness	t_1	t_1	$\frac{1.5}{(0.059)}$	max.
Splice sprocket hole alignment			0	$\frac{\pm 0.3}{(\pm 0.012)}$
Front-to-back deviation	Δ_h	Δ_h	0	$\frac{\pm 1.0}{(\pm 0.039)}$
Side-to-side deviation	Δ_p	Δ_p	0	$\frac{\pm 1.3}{(\pm 0.051)}$
Ordinate to adjacent component lead	P_1	P_1	$\frac{3.81}{(0.150)}$	$\frac{\pm 0.7}{(\pm 0.028)}$
Lead spacing	F	F	$\frac{5.08}{(0.2)}$	$\frac{+0.6/-0.2}{(+0.024/-0.008)}$
Reel width including flanges and hub	W_4	w_2	$\frac{62.0}{(2.44)}$	max.
Dimension between flanges (measured at hub)	W_3	w_1	allow proper reeling and unreeling	
Reel diameter	A	a	$\frac{370.0}{(14.57)}$	max.

— Continued on next page —

DIMENSIONS: $\frac{\text{MM}}{\text{(INCHES)}}$

Specifications are subject to change without notice.

Users should verify actual device performance in their specific applications.

The products described herein and this document are subject to specific legal disclaimers as set forth on the last page of this document, and at www.bourns.com/docs/legal/disclaimer.pdf.

MF-RX/250 Series Tape and Reel Specifications

BOURNS®

Dimension Description	IEC Mark	EIA Mark	Dimensions			
			Dimensions	Tolerance		
Space between flanges (at hub, excluding device)			4.75 (0.187)	± 3.25 (± 0.128)		
Arbor hole diameter	C	c	26.0 (1.024)	± 12.0 (± 0.472)		
Core diameter	N	n	80 (3.15)	min.		
Box dimensions			62 (2.44)	372 (14.6)	372 (14.6)	max.
Consecutive missing places			3	max.		
Empty places per reel			Less than 0.1 %			

Taped Component Dimensions - per EIA Mark - Figure 1

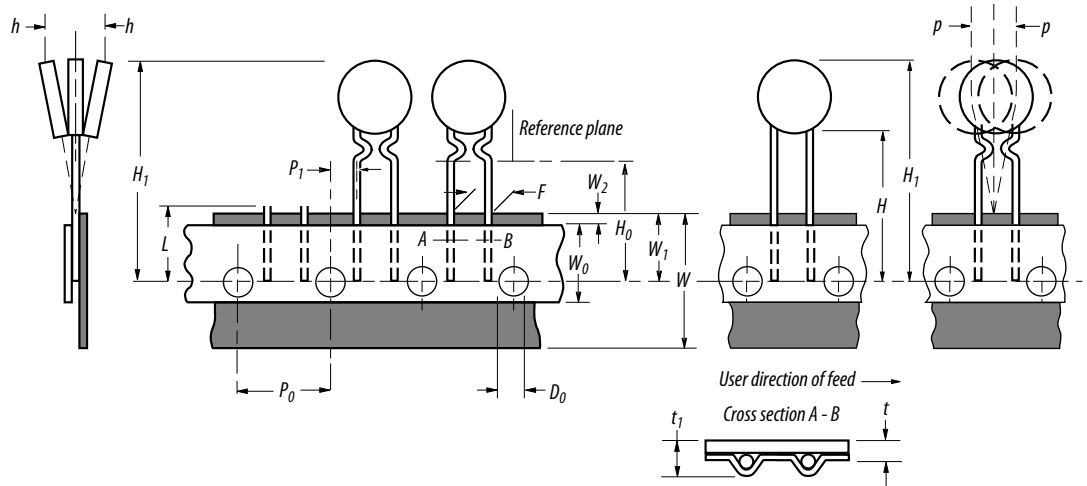

Reel Dimensions - per EIA Mark - Figure 2

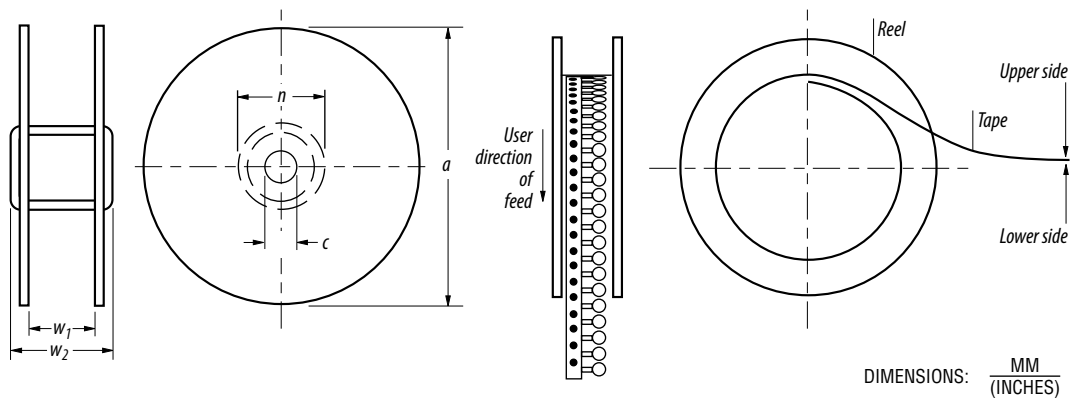

MF-RX/250, REV. O 10/20

Specifications are subject to change without notice.

Users should verify actual device performance in their specific applications.

The products described herein and this document are subject to specific legal disclaimers as set forth on the last page of this document, and at www.bourns.com/docs/legal/disclaimer.pdf.

Application Notice

- Users are responsible for independent and adequate evaluation of Bourns® Multifuse® Polymer PTC devices in the user's application, including the PPTC device characteristics stated in the applicable data sheet.
- Polymer PTC devices must not be allowed to operate beyond their stated maximum ratings. Operation in excess of such maximum ratings could result in damage to the PTC device and possibly lead to electrical arcing and/or fire. Circuits with inductance may generate a voltage above the rated voltage of the polymer PTC device and should be thoroughly evaluated within the user's application during the PTC selection and qualification process.
- Polymer PTC devices are intended to protect against adverse effects of temporary overcurrent or overtemperature conditions up to rated limits and are not intended to serve as protective devices where overcurrent or overvoltage conditions are expected to be repetitive or prolonged.
- In normal operation, polymer PTC devices experience thermal expansion under fault conditions. Thus, a polymer PTC device must be protected against mechanical stress, and must be given adequate clearance within the user's application to accommodate such thermal expansion. Rigid potting materials or fixed housings or coverings that do not provide adequate clearance should be thoroughly examined and tested by the user, as they may result in the malfunction of polymer PTC devices if the thermal expansion is inhibited.
- Exposure to lubricants, silicon-based oils, solvents, gels, electrolytes, acids, and other related or similar materials may adversely affect the performance of polymer PTC devices.
- Aggressive solvents may adversely affect the performance of polymer PTC devices. Conformal coating, encapsulating, potting, molding, and sealing materials may contain aggressive solvents including but not limited to xylene and toluene, which are known to cause adverse effects on the performance of polymer PTCs. Such aggressive solvents must be thoroughly cured or baked to ensure their complete removal from polymer PTCs to minimize the possible adverse effect on the device.
- Recommended storage conditions should be followed at all times. Such conditions can be found on the applicable data sheet and on the Multifuse® Polymer PTC Moisture/Reflow Sensitivity Classification (MSL) note:
https://www.bourns.com/docs/RoHS-MSL/msl_mf.pdf