

## Features

- Very low profile
- Very fast tripping time
- High voltage
- RoHS compliant\* and halogen free\*\*
- 2018 footprint
- Agency recognition:  

## Additional Information

Click these links for more information:



[PRODUCT SELECTOR](#) [TECHNICAL LIBRARY](#) [INVENTORY](#) [SAMPLES](#) [CONTACT](#)

## MF-SMDF Series – PTC Resettable Fuses

### Electrical Characteristics

Model	V <sub>max</sub>	I <sub>max</sub>	I <sub>hold</sub>	I <sub>trip</sub>	Resistance		Max. Time To Trip		Tripped Power Dissipation	Agency Recognition	
					at 23 °C		at 23 °C	at 23 °C		Watts at 23 °C	cUL
	Volts	Amps	Amps	Amps	R <sub>min</sub>	R <sub>1max</sub>	Amps	Seconds	Typ.	E174545	R50256634
MF-SMDF030	60	20	0.30	0.8	0.45	2.15	1.5	1.2	0.8	✓	
MF-SMDF050	60	10	0.55	1.2	0.20	1.00	2.5	3.0	0.9	✓	✓
MF-SMDF100/33X	33	40	1.1	2.2	0.06	0.40	8.0	0.5	1.4	✓	
MF-SMDF150	15	40	1.5	3.0	0.05	0.17	8.0	0.8	1.1	✓	✓
MF-SMDF200	10	40	2.0	4.0	0.03	0.10	8.0	2.4	1.1		
MF-SMDF260/24X	24	20	2.6	5.2	0.015	0.075	8.0	5.0	1.5	✓	✓

### Environmental Characteristics

Item	Condition	Criteria
Operating Temperature	-40 °C to +85 °C	
Recommended Storage	+40 °C max. / 70 % R.H. max.	
Passive Aging	+85 °C, 1000 hours	±5 % typical resistance change
Humidity Aging	MF-SMDF030, 050, 150, 200	±1.2 % typical resistance change
	MF-SMDF100/33X, 260/24X	±5 % typical resistance change
Thermal Shock	MF-SMDF030, 050, 150, 200	-20 % typical resistance change
	MF-SMDF100/33X, 260/24X	±10 % typical resistance change
Solvent Resistance	MIL-STD-202, Method 215	No change (marking still legible)
Vibration	MIL-STD-883C, Method 2007.1 Condition A	No change (R <sub>min</sub> < R < R <sub>1max</sub> )
Moisture Sensitivity Level (MSL)	<a href="#">See Note</a>	
ESD Classification	Class 6 (per AEC-Q200-2, HBM)	

### Test Procedures and Requirements

Item	Test Conditions	Accept/Reject Criteria
Visual/Mechanical	Verify dimensions and materials	Per MF physical description
Resistance	In still air @ 23 °C	R <sub>min</sub> ≤ R ≤ R <sub>max</sub>
Time to Trip	At specified current, V <sub>max</sub> , 23 °C, still air	T ≤ max. time to trip (seconds)
Hold Current	30 min. at I <sub>hold</sub> , still air	No trip
Trip Cycle Life	V <sub>max</sub> , I <sub>max</sub> , 100 cycles	No arcing or burning
Trip Endurance	V <sub>max</sub> , 48 hours	No arcing or burning
Solderability	245 °C ±5 °C, 5 seconds	95 % min. coverage



**WARNING**  
**Cancer and Reproductive Harm**  
[www.P65Warnings.ca.gov](http://www.P65Warnings.ca.gov)

\*\* Bourns considers a product to be "halogen free" if (a) the Bromine (Br) content is 900 ppm or less; (b) the Chlorine (Cl) content is 900 ppm or less; and (c) the total Bromine (Br) and Chlorine (Cl) content is 1500 ppm or less.

Specifications are subject to change without notice. Users should verify actual device performance in their specific applications. The products described herein and this document are subject to specific legal disclaimers as set forth on the last page of this document, and at [www.bourns.com/docs/legal/disclaimer.pdf](http://www.bourns.com/docs/legal/disclaimer.pdf).

\* RoHS Directive 2015/863, Mar 31, 2015 and Annex.

## Applications

- Power Over Ethernet (IEEE 802.3 af) port protection
- Automotive electronic control module protection
- Telecom equipment low voltage protection

## MF-SMDF Series – PTC Resettable Fuses

**BOURNS®**

Thermal Derating Table -  $I_{hold}$  (Amps)

Model	Ambient Operating Temperature								
	-40 °C	-20 °C	0 °C	23 °C	40 °C	50 °C	60 °C	70 °C	85 °C
MF-SMDF030	0.50	0.43	0.37	0.30	0.25	0.22	0.18	0.15	0.11
MF-SMDF050	0.87	0.77	0.67	0.55	0.46	0.41	0.36	0.31	0.23
MF-SMDF100/33X	1.66	1.47	1.29	1.10	0.91	0.83	0.73	0.64	0.50
MF-SMDF150	2.38	2.10	1.82	1.50	1.27	1.13	0.99	0.85	0.64
MF-SMDF200	2.95	2.65	2.35	2.00	1.74	1.59	1.44	1.29	1.06
MF-SMDF260/24X	3.75	3.35	3.00	2.60	2.35	2.15	2.05	1.80	1.50

$I_{trip}$  is approximately two times  $I_{hold}$ .

Product Dimensions

Model	A		B		C		D	E		Style
	Min.	Max.	Min.	Max.	Min.	Max.	Min.	Min.	Max.	
MF-SMDF030	$\frac{4.72}{(0.186)}$	$\frac{5.44}{(0.214)}$	$\frac{4.22}{(0.166)}$	$\frac{4.93}{(0.194)}$	$\frac{0.79}{(0.031)}$	$\frac{1.09}{(0.043)}$	$\frac{0.30}{(0.012)}$	N/A	N/A	1
MF-SMDF050	$\frac{4.72}{(0.186)}$	$\frac{5.44}{(0.214)}$	$\frac{4.22}{(0.166)}$	$\frac{4.93}{(0.194)}$	$\frac{0.79}{(0.031)}$	$\frac{1.09}{(0.043)}$	$\frac{0.30}{(0.012)}$	N/A	N/A	1
MF-SMDF100/33X	$\frac{4.72}{(0.186)}$	$\frac{5.44}{(0.214)}$	$\frac{4.22}{(0.166)}$	$\frac{4.93}{(0.194)}$	$\frac{0.70}{(0.028)}$	$\frac{1.25}{(0.049)}$	$\frac{0.30}{(0.012)}$	$\frac{0.25}{(0.010)}$	$\frac{0.70}{(0.028)}$	2
MF-SMDF150	$\frac{4.72}{(0.186)}$	$\frac{5.44}{(0.214)}$	$\frac{4.22}{(0.166)}$	$\frac{4.93}{(0.194)}$	$\frac{0.55}{(0.022)}$	$\frac{0.85}{(0.033)}$	$\frac{0.30}{(0.012)}$	N/A	N/A	1
MF-SMDF200	$\frac{4.72}{(0.186)}$	$\frac{5.44}{(0.214)}$	$\frac{4.22}{(0.166)}$	$\frac{4.93}{(0.194)}$	$\frac{0.55}{(0.022)}$	$\frac{0.85}{(0.033)}$	$\frac{0.30}{(0.012)}$	N/A	N/A	1
MF-SMDF260/24X	$\frac{4.72}{(0.186)}$	$\frac{5.44}{(0.214)}$	$\frac{4.22}{(0.166)}$	$\frac{4.93}{(0.194)}$	$\frac{0.70}{(0.028)}$	$\frac{2.00}{(0.079)}$	$\frac{0.30}{(0.012)}$	$\frac{0.25}{(0.010)}$	$\frac{0.70}{(0.028)}$	3

DIMENSIONS:  $\frac{MM}{(INCHES)}$

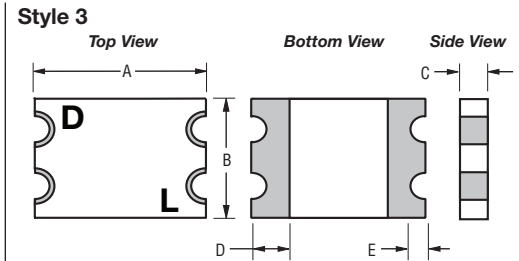
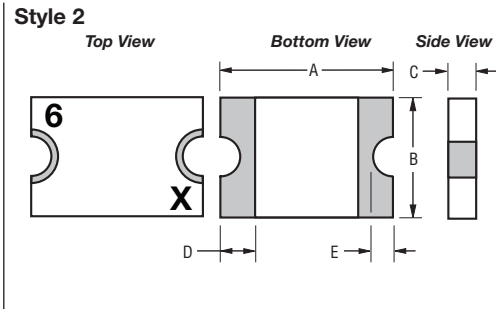
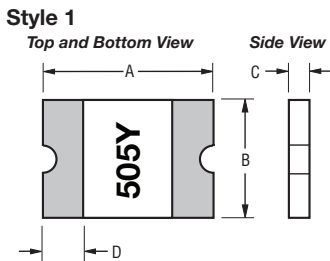

**Terminal material:**  
Electroless Ni under immersion Au

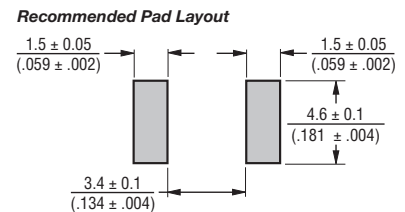

Specifications are subject to change without notice.

Users should verify actual device performance in their specific applications.

The products described herein and this document are subject to specific legal disclaimers as set forth on the last page of this document, and at [www.bourns.com/docs/legal/disclaimer.pdf](http://www.bourns.com/docs/legal/disclaimer.pdf).

# MF-SMDF Series – PTC Resettable Fuses



## Packaging Quantity

Model	Unit Quantity (pcs.)	Unit
MF-SMDF030 MF-SMDF050	6000	Reel
MF-SMDF100/33X MF-SMDF150		
MF-SMDF260/24X	4000	Reel

## Typical Part Marking

Represents total content. Layout may vary.

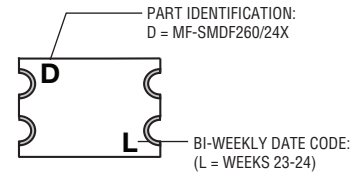
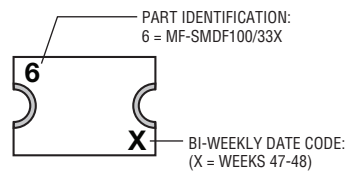
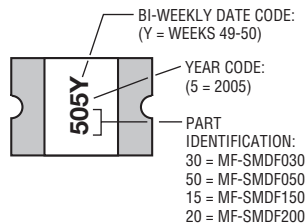

## Solder Reflow Recommendations

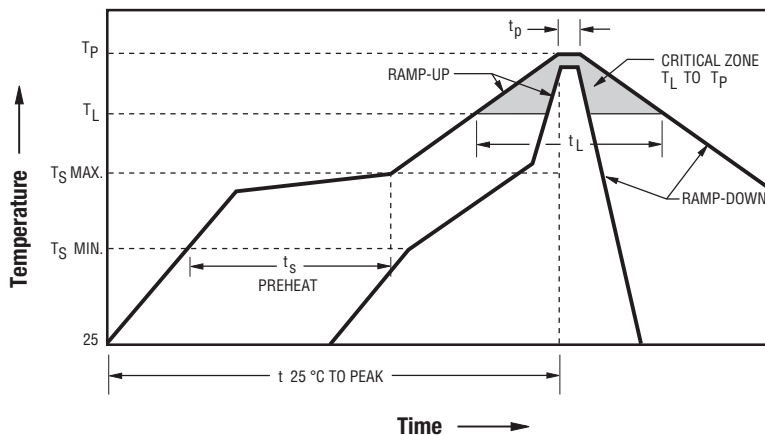

### Notes:

- MF-SMDF models are intended for reflow soldering (including but not limited to heating plate, hot air, IR, nitrogen, and vapor phase).
- Wave soldering is permissible only if the device is on the top of the PCB, opposite the heat source.
- Hand soldering is not recommended for these devices.
- All temperatures refer to the topside of the device, measured on the device body surface.
- If reflow temperatures exceed the recommended profile, devices may not meet the published specifications.
- Compatible with Pb and Pb-free solder reflow profiles.
- Excess solder may cause a short circuit.
- Please refer to the [Multifuse® Polymer PTC Resettable Fuse Soldering Recommendations](#) document for more details.

Profile Feature	Pb-Free Assembly
Average Ramp-Up Rate ( $T_{s_{max}}$ to $T_p$ )	3 °C / second max.
PREHEAT:	
Temperature Min. ( $T_{s_{min}}$ )	150 °C
Temperature Max. ( $T_{s_{max}}$ )	200 °C
Time ( $T_{s_{min}}$ to $T_{s_{max}}$ ) (ts)	60~180 seconds
TIME MAINTAINED ABOVE:	
Temperature ( $T_L$ )	217 °C
Time ( $t_L$ )	60~150 seconds
Peak Temperature ( $T_p$ )	260 °C
Time within 5 °C of Actual Peak Temperature ( $t_p$ )	20~40 seconds
Ramp-Down Rate	6 °C / second max.
Time 25 °C to Peak Temperature	8 minutes max.

Specifications are subject to change without notice.

Users should verify actual device performance in their specific applications.

The products described herein and this document are subject to specific legal disclaimers as set forth on the last page of this document, and at [www.bourns.com/docs/legal/disclaimer.pdf](http://www.bourns.com/docs/legal/disclaimer.pdf).

# MF-SMDF Series – PTC Resettable Fuses



## Typical Time to Trip at 23 °C

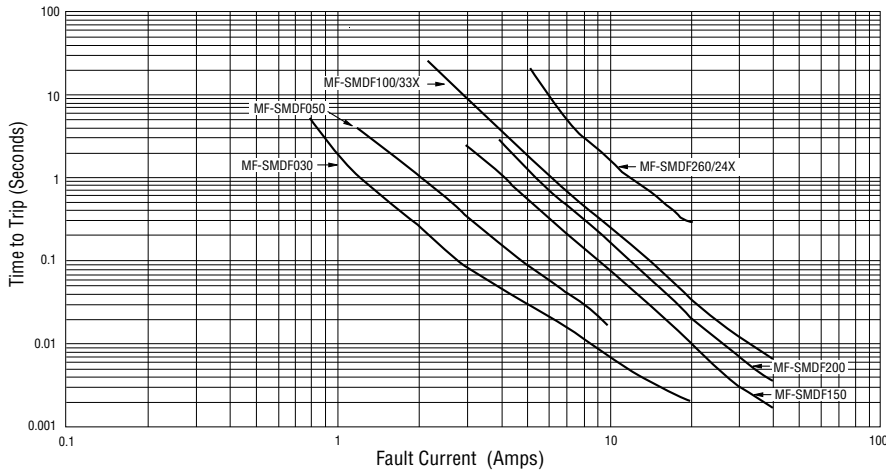

The Time to Trip curves represent typical performance of a device in a simulated application environment. Actual performance in specific customer applications may differ from these values due to the influence of other variables.

## How to Order

**MF - SMDF 100 /33X - 2**

Product Designator \_\_\_\_\_  
 Series \_\_\_\_\_  
 SMDF = 2018 Surface Mount Component  
 Hold Current,  $I_{hold}$  \_\_\_\_\_  
 030 = 0.30 A  
 050 = 0.50 A  
 100 = 1.10 A  
 150 = 1.50 A  
 200 = 2.00 A  
 260 = 2.60 A  
 Higher Voltage Option \_\_\_\_\_  
 = Standard Voltage  
 /24X = 24 V Rated  
 /33X = 33 V Rated  
 X = Multifuse® freeXpansion Design™  
 MF-SMDF Series  
 Packaging \_\_\_\_\_  
 -2 = Tape and Reel Packaged per EIA-481



**Asia-Pacific:** Tel: +886-2 2562-4117 • Email: asiacus@bourns.com

**EMEA:** Tel: +36 88 885 877 • Email: eurocus@bourns.com

**The Americas:** Tel: +1-951 781-5500 • Email: americus@bourns.com

[www.bourns.com](http://www.bourns.com)

Specifications are subject to change without notice.

Users should verify actual device performance in their specific applications.

The products described herein and this document are subject to specific legal disclaimers as set forth on the last page of this document, and at [www.bourns.com/docs/legal/disclaimer.pdf](http://www.bourns.com/docs/legal/disclaimer.pdf).

# MF-SMDF Series Tape and Reel Specifications

**BOURNS®**

Tape Dimensions per EIA 481	MF-SMDF030, 050, 150, 200	MF-SMDF100/33X	MF-SMDF260/24X
W	$\frac{16.0 \pm 0.3}{(0.630 \pm 0.012)}$	$\frac{16.0 \pm 0.3}{(0.630 \pm 0.012)}$	$\frac{16.0 \pm 0.3}{(0.630 \pm 0.012)}$
P <sub>0</sub>	$\frac{4.0 \pm 0.1}{(0.157 \pm 0.004)}$	$\frac{4.0 \pm 0.1}{(0.157 \pm 0.004)}$	$\frac{4.0 \pm 0.1}{(0.157 \pm 0.004)}$
10P <sub>0</sub>	$\frac{40 \pm 0.2}{(1.575 \pm 0.008)}$	$\frac{40 \pm 0.2}{(1.575 \pm 0.008)}$	$\frac{40 \pm 0.2}{(1.575 \pm 0.008)}$
P <sub>1</sub>	$\frac{8.0 \pm 0.1}{(0.315 \pm 0.004)}$	$\frac{8.0 \pm 0.1}{(0.315 \pm 0.004)}$	$\frac{8.0 \pm 0.1}{(0.315 \pm 0.004)}$
P <sub>2</sub>	$\frac{2.0 \pm 0.1}{(0.079 \pm 0.004)}$	$\frac{2.0 \pm 0.1}{(0.079 \pm 0.004)}$	$\frac{2.0 \pm 0.1}{(0.079 \pm 0.004)}$
A <sub>0</sub>	$\frac{5.1 \pm 0.15}{(0.201 \pm 0.006)}$	$\frac{5.1 \pm 0.15}{(0.201 \pm 0.006)}$	$\frac{5.4 \pm 0.15}{(0.213 \pm 0.006)}$
B <sub>0</sub>	$\frac{5.6 \pm 0.15}{(0.220 \pm 0.006)}$	$\frac{5.6 \pm 0.15}{(0.221 \pm 0.006)}$	$\frac{5.7 \pm 0.15}{(0.234 \pm 0.006)}$
B <sub>1</sub> max.	$\frac{12.1}{(0.476)}$	$\frac{12.1}{(0.476)}$	$\frac{12.1}{(0.476)}$
D <sub>0</sub>	$\frac{1.5 + 0.1/-0.0}{(0.059 + 0.004/-0)}$	$\frac{1.5 + 0.1/-0.0}{(0.059 + 0.004/-0)}$	$\frac{1.5 + 0.1/-0.0}{(0.059 + 0.004/-0)}$
F	$\frac{7.5 \pm 0.10}{(0.295 + 0.004)}$	$\frac{7.5 \pm 0.10}{(0.295 + 0.004)}$	$\frac{7.5 \pm 0.10}{(0.295 + 0.004)}$
E <sub>1</sub>	$\frac{1.75 \pm 0.10}{(0.069 \pm 0.004)}$	$\frac{1.75 \pm 0.10}{(0.069 \pm 0.004)}$	$\frac{1.75 \pm 0.10}{(0.069 \pm 0.004)}$
E <sub>2</sub> min.	$\frac{14.25}{(0.561)}$	$\frac{14.25}{(0.561)}$	$\frac{14.25}{(0.561)}$
T max.	$\frac{0.6}{(0.024)}$	$\frac{0.6}{(0.024)}$	$\frac{0.6}{(0.024)}$
T <sub>1</sub> max.	$\frac{0.1}{(0.004)}$	$\frac{0.1}{(0.004)}$	$\frac{0.1}{(0.004)}$
K <sub>0</sub>	$\frac{1.1 \pm 0.15}{(0.043 \pm 0.006)}$	$\frac{1.1 \pm 0.15}{(0.043 \pm 0.006)}$	$\frac{2.15 \pm 0.15}{(0.085 \pm 0.006)}$
Leader min.	$\frac{390}{(15.35)}$	$\frac{390}{(15.35)}$	$\frac{390}{(15.35)}$
Trailer min.	$\frac{160}{(6.30)}$	$\frac{160}{(6.30)}$	$\frac{160}{(6.30)}$
<b>Reel Dimensions</b>			
A max.	$\frac{331}{(13.03)}$	$\frac{331}{(13.03)}$	$\frac{331}{(13.03)}$
N min.	$\frac{50}{(1.97)}$	$\frac{50}{(1.97)}$	$\frac{50}{(1.97)}$
W <sub>1</sub>	$\frac{16.4 + 2.0/-0.0}{(0.646 + 0.079/-0)}$	$\frac{16.4 + 2.0/-0.0}{(0.646 + 0.079/-0)}$	$\frac{16.4 + 2.0/-0.0}{(0.646 + 0.079/-0)}$
W <sub>2</sub> max.	$\frac{22.4}{(0.882)}$	$\frac{22.4}{(0.882)}$	$\frac{22.4}{(0.882)}$

DIMENSIONS:  $\frac{\text{MM}}{\text{(INCHES)}}$

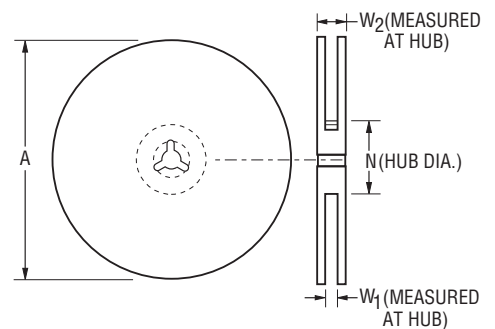
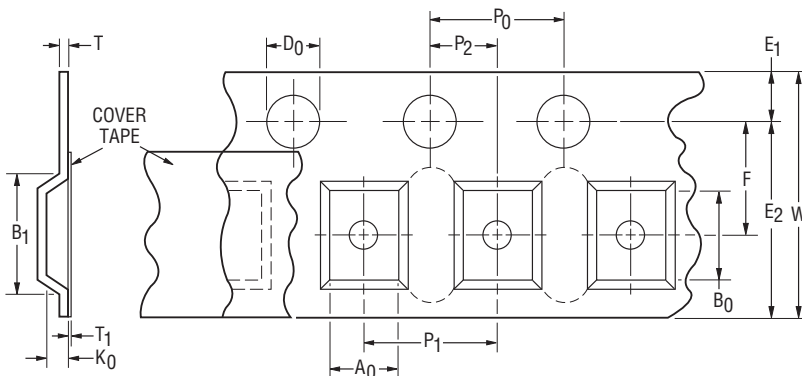

MF-SMDF SERIES, REV. W, 02/23

Specifications are subject to change without notice.

Users should verify actual device performance in their specific applications.

The products described herein and this document are subject to specific legal disclaimers as set forth on the last page of this document, and at [www.bourns.com/docs/legal/disclaimer.pdf](http://www.bourns.com/docs/legal/disclaimer.pdf).

**Application Notice**

- Users are responsible for independent and adequate evaluation of Bourns® Multifuse® Polymer PTC devices in the user's application, including the PPTC device characteristics stated in the applicable data sheet.
- Polymer PTC devices must not be allowed to operate beyond their stated maximum ratings. Operation in excess of such maximum ratings could result in damage to the PTC device and possibly lead to electrical arcing and/or fire. Circuits with inductance may generate a voltage above the rated voltage of the polymer PTC device and should be thoroughly evaluated within the user's application during the PTC selection and qualification process.
- Polymer PTC devices are intended to protect against adverse effects of temporary overcurrent or overtemperature conditions up to rated limits and are not intended to serve as protective devices where overcurrent or overvoltage conditions are expected to be repetitive or prolonged.
- In normal operation, polymer PTC devices experience thermal expansion under fault conditions. Thus, a polymer PTC device must be protected against mechanical stress, and must be given adequate clearance within the user's application to accommodate such thermal expansion. Rigid potting materials or fixed housings or coverings that do not provide adequate clearance should be thoroughly examined and tested by the user, as they may result in the malfunction of polymer PTC devices if the thermal expansion is inhibited.
- Exposure to lubricants, silicon-based oils, solvents, gels, electrolytes, acids, and other related or similar materials may adversely affect the performance of polymer PTC devices.
- Aggressive solvents may adversely affect the performance of polymer PTC devices. Conformal coating, encapsulating, potting, molding, and sealing materials may contain aggressive solvents including but not limited to xylene and toluene, which are known to cause adverse effects on the performance of polymer PTCs. Such aggressive solvents must be thoroughly cured or baked to ensure their complete removal from polymer PTCs to minimize the possible adverse effect on the device.
- Recommended storage conditions should be followed at all times. Such conditions can be found on the applicable data sheet and on the Multifuse® Polymer PTC Moisture/Reflow Sensitivity Classification (MSL) note:  
[https://www.bourns.com/docs/RoHS-MSL/msl\\_mf.pdf](https://www.bourns.com/docs/RoHS-MSL/msl_mf.pdf)