





Features

- Surface mount packaging for automated assembly
- Small footprint size (1210) and low profile for space-constrained mobile applications
- Ultra-low resistance, quick response
- RoHS compliant*
- Agency recognition:  

MF-USML/X Series - Low Ohmic PTC Resettable Fuses

Electrical Characteristics

Model	V max.	I max.	I _{hold}	I _{trip}	Resistance		Max. Time To Trip		Tripped Power Dissipation	Certifications	
			at 23 °C		at 23 °C Ohms		at 23 °C		Watts at 23 °C	cUL	TÜV
	Volts	Amps	Amps	R _{min}	R _{1max}	Amps	Seconds	Typ.	E174545	R50391579	
MF-USML175/12	12	50	1.75	3.5	0.006	0.050	8.0	0.8	1.0	✓	✓
MF-USML200/12	12	50	2.0	4.0	0.005	0.040	8.0	5.0	1.0	✓	✓
MF-USML260/12	12	50	2.6	5.2	0.004	0.030	8.0	5.0	1.0	✓	✓
MF-USML300/12	12	50	3.0	6.0	0.003	0.024	15.0	5.0	1.0	✓	✓
MF-USML350/12	12	50	3.5	7.0	0.002	0.022	17.0	5.0	1.0	✓	✓
MF-USML380/12	12	50	3.8	7.6	0.002	0.020	19.0	5.0	1.0	✓	✓
MF-USML400/12	12	50	4.0	8.0	0.002	0.018	20.0	5.0	1.0	✓	✓
MF-USML450/12	12	50	4.5	9.0	0.002	0.014	22.5	2.0	1.0	✓	✓
MF-USML500/12	12	50	5.0	10.0	0.001	0.012	25.0	2.0	1.2	✓	✓
MF-USML550/12	12	50	5.5	11.0	0.001	0.010	27.5	2.0	1.2	✓	✓

Environmental Characteristics

Operating Temperature.....	-40 °C to +85 °C
Storage Condition	
Before Opening	+40 °C max. / 70 % RH max.
After Opening.....	+40 °C max. / 10 % RH max.
Floor Condition After Opening	Consumption within 4 weeks at floor condition +30 °C max. / 60 % RH max.
Passive Aging.....	+85 °C, 1000 hours..... ±10 % typical resistance change
Humidity Aging.....	+85 °C, 85 % R.H. 100 hours ±15 % typical resistance change
Thermal Shock	+85 °C to -40 °C, 20 times..... ±30 % typical resistance change
Solvent Resistance.....	MIL-STD-202, Method 215 No change (marking still legible)
Vibration	MIL-STD-883C, Method 2007.1,..... No change (R _{min} <R<R _{1max}) Condition A
Moisture Sensitivity Level (MSL)	See Note
ESD Classification - HBM.....	6

Test Procedures and Requirements

Test	Test Conditions	Accept/Reject Criteria
Visual/Mech.....	Verify dimensions and materials.....	Per MF physical description
Resistance.....	In still air @ 23 °C.....	R _{min} ≤ R ≤ R _{1max}
Time to Trip.....	At specified current, V _{max} , 23 °C.....	T ≤ max. time to trip (seconds)
Hold Current.....	30 min. at I _{hold}	No trip
Trip Cycle Life.....	V _{max} , I _{max} , 100 cycles.....	No arcing or burning
Trip Endurance.....	V _{max} , 48 hours.....	No arcing or burning
Solderability.....	245 °C ±5 °C, 5 seconds.....	95 % min. coverage



WARNING Cancer and Reproductive Harm - www.P65Warnings.ca.gov

* RoHS Directive 2015/863, Mar 31, 2015 and Annex.

** Bourns considers a product to be "halogen free" if (a) the Bromine (Br) content is 900 ppm or less; (b) the Chlorine (Cl) content is 900 ppm or less; and (c) the total Bromine (Br) and Chlorine (Cl) content is 1500 ppm or less.

Specifications are subject to change without notice.

Users should verify actual device performance in their specific applications.

The products described herein and this document are subject to specific legal disclaimers as set forth on the last page of this document, and at www.bourns.com/docs/legal/disclaimer.pdf.

Applications

- Li-ion battery pack protection
- Power delivery port protection
- Higher voltage withstand
- PC motherboards – Plug & Play protection
- Mobile phones – battery & charging protection
- USB port protection
- Game console port protection

MF-USML/X Series – Low Ohmic PTC Resettable Fuses

BOURNS®

Product Dimensions

Model	A		B		C		D	E	
	Min.	Max.	Min.	Max.	Min.	Max.	Min.	Min.	Max.
MF-USML175/12	$\frac{3.00}{(0.12)}$	$\frac{3.43}{(0.14)}$	$\frac{2.35}{(0.09)}$	$\frac{2.80}{(0.11)}$	$\frac{0.40}{(0.016)}$	$\frac{0.80}{(0.031)}$	$\frac{0.25}{(0.010)}$	$\frac{0.05}{(0.002)}$	$\frac{0.45}{(0.018)}$
MF-USML200/12									
MF-USML260/12									
MF-USML300/12	$\frac{3.00}{(0.12)}$	$\frac{3.43}{(0.14)}$	$\frac{2.35}{(0.09)}$	$\frac{2.80}{(0.11)}$	$\frac{0.60}{(0.024)}$	$\frac{1.20}{(0.047)}$	$\frac{0.25}{(0.010)}$	$\frac{0.05}{(0.002)}$	$\frac{0.45}{(0.018)}$
MF-USML350/12									
MF-USML380/12									
MF-USML400/12									
MF-USML450/12									
MF-USML500/12									
MF-USML550/12									

DIMENSIONS: $\frac{\text{MM}}{(\text{INCHES})}$

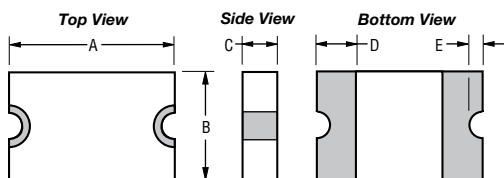

Terminal material:
ENIG-plated terminals

Recommended Pad Layout

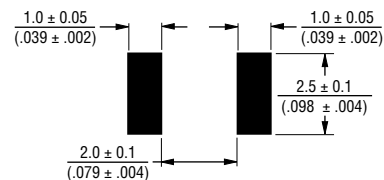

Packaging Quantity

MF-USML175/12 ~ MF-USML260/12 = 5000 pcs. per reel
MF-USML300/12 ~ MF-USML550/12 = 3500 pcs. per reel

Thermal Derating Table - I_{hold} (Amps)

Model	Ambient Operating Temperature								
	-40 °C	-20 °C	0 °C	23 °C	40 °C	50 °C	60 °C	70 °C	85 °C
MF-USML175/12	2.57	2.33	2.07	1.75	1.49	1.34	1.24	1.00	0.88
MF-USML200/12	2.94	2.65	2.35	2.00	1.70	1.53	1.42	1.14	1.00
MF-USML260/12	3.82	3.46	3.07	2.60	2.21	1.95	1.85	1.48	1.30
MF-USML300/12	4.41	3.99	3.54	3.00	2.55	2.30	2.13	1.71	1.50
MF-USML350/12	5.10	4.65	4.13	3.50	2.98	2.65	2.50	2.00	1.75
MF-USML380/12	5.59	5.05	4.48	3.80	3.23	2.95	2.70	2.17	1.90
MF-USML400/12	5.80	5.25	4.70	4.00	3.40	3.10	2.80	2.28	2.00
MF-USML450/12	6.30	5.65	4.95	4.50	3.83	3.40	2.95	2.50	2.05
MF-USML500/12	7.00	6.25	5.50	5.00	4.25	3.75	3.25	2.75	2.25
MF-USML550/12	7.70	6.90	6.05	5.50	4.68	4.15	3.60	3.05	2.40

Specifications are subject to change without notice.

Users should verify actual device performance in their specific applications.

The products described herein and this document are subject to specific legal disclaimers as set forth on the last page of this document, and at www.bourns.com/docs/legal/disclaimer.pdf.

MF-USML/X Series – Low Ohmic PTC Resettable Fuses



Solder Reflow Recommendations

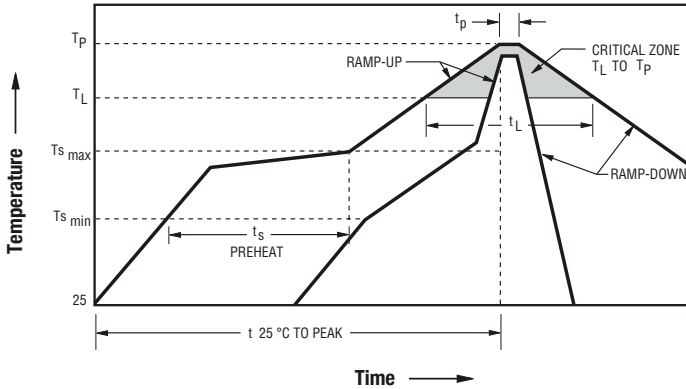

Notes:

- MF-USML/X models cannot be wave soldered or hand soldered. Please contact Bourns for soldering recommendations.
- All temperatures refer to topside of the package, measured on the package body surface.
- If reflow temperatures exceed the recommended profile, devices may not meet the published specifications.
- Compatible with Pb and Pb-free solder reflow profiles.
- Excess solder may cause a short circuit. Please refer to the Multifuse® Polymer PTC Soldering Recommendation guidelines.

Profile Feature	Pb-Free Assembly
Average Ramp-Up Rate ($T_{s_{max}}$ to T_p)	3 °C / second max.
PREHEAT: Temperature Min. ($T_{s_{min}}$) Temperature Max. ($T_{s_{max}}$) Time ($T_{s_{min}}$ to $T_{s_{max}}$) (t_s)	150 °C 200 °C 60~180 seconds
TIME MAINTAINED ABOVE: Temperature (T_L) Time (t_L)	217 °C 60~150 seconds
Peak Temperature (T_p)	260 °C
Time within 5 °C of Actual Peak Temperature (t_p)	20~40 seconds
Ramp-Down Rate	6 °C / second max.
Time 25 °C to Peak Temperature	8 minutes max.

How to Order

MF - USML 400 / 12 - 2

Multifuse® _____
Product Designator _____
Series _____
USML = 1210 Low Ohmic
Surface Mount Component
Hold Current, I_{hold} _____
175 - 550 (1.75 Amps - 5.50 Amps)
Maximum Voltage, V_{max} _____
12 = 12 Volts
Packaging _____
-2 = Tape and Reel
Packaged per EIA 481

Typical Part Marking

Represents total content. Layout may vary.

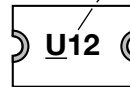

PART IDENTIFICATION:
MF-USML175/12 = H12
MF-USML200/12 = J12
MF-USML260/12 = N12
MF-USML300/12 = P12
MF-USML350/12 = S12
MF-USML380/12 = V12
MF-USML400/12 = U12
MF-USML450/12 = X12
MF-USML500/12 = Y12
MF-USML550/12 = S12

MANUFACTURING DATE CODE IS
LOCATED ON PACKING LABEL.

MF-USML/X SERIES, REV. A, 03/19

Specifications are subject to change without notice.

Users should verify actual device performance in their specific applications.

The products described herein and this document are subject to specific legal disclaimers as set forth on the last page of this document, and at www.bourns.com/docs/legal/disclaimer.pdf.

MF-USML/X Series – Low Ohmic PTC Resettable Fuses

BOURNS®

Packaging Specifications

MF-USML/X Series per EIA 481

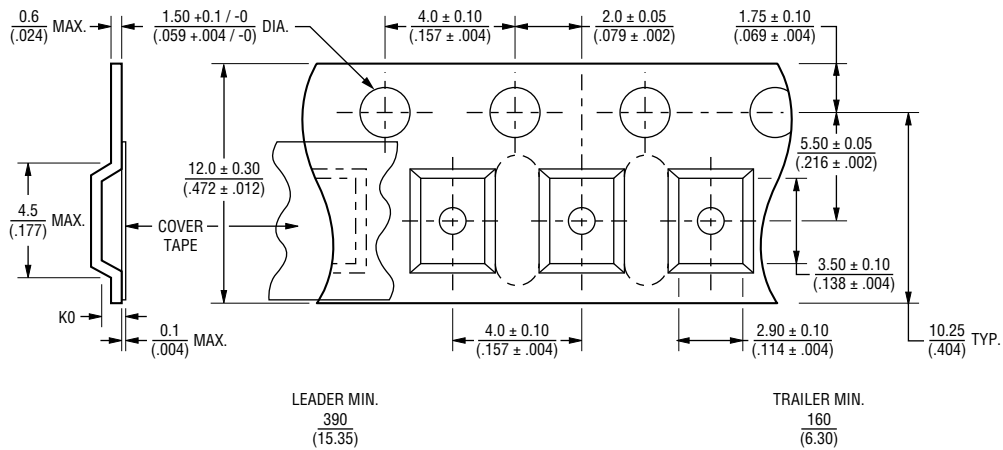

K0	
0.65 ± 0.10 (.026 ± .004)	MF-USML175/12 ~ MF-USML260/12
1.10 ± 0.10 (.043 ± .004)	MF-USML300/12 ~ MF-USML550/12

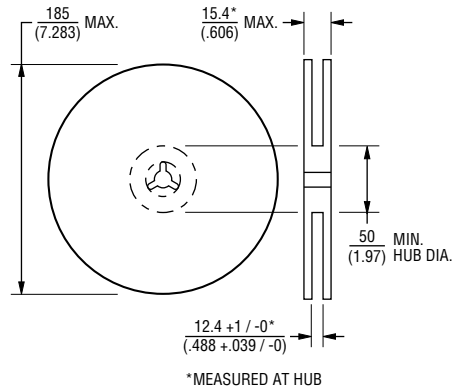

DIMENSIONS: $\frac{\text{MM}}{\text{(INCHES)}}$

BOURNS®

Asia-Pacific: Tel: +886-2 2562-4117 • Email: asiacus@bourns.com

EMEA: Tel: +36 88 885 877 • Email: eurocus@bourns.com

The Americas: Tel: +1-951 781-5500 • Email: americus@bourns.com

www.bourns.com

Specifications are subject to change without notice.

Users should verify actual device performance in their specific applications.

The products described herein and this document are subject to specific legal disclaimers as set forth on the last page of this document, and at www.bourns.com/docs/legal/disclaimer.pdf.