

## MG08-D SERIES ENTERPRISE CAPACITY HDD

The Enterprise Capacity 7200 rpm HDD models offer up to 8 TB<sup>[1]</sup>, a choice of interface (SATA -MG08ADA Series, and SAS - MG08SDA Series), as well as a choice of 512 Native(512n) sector or 512 emulation(512e) sector technologies. All models utilize a power-efficient mechanical design incorporating the latest advancements in HDD technology. MG08-D Series models are designed to provide plug-and-play robustness using the industry standard 3.5-inch<sup>[2]</sup> form factor. Model options supporting Sanitize Instant Erase (SIE) and Self-Encrypting Drive (SED).



Product image may represent a design model.

### KEY FEATURES

- Industry Standard 3.5-inch 26.1 mm Height Form Factor
- Up to 8 TB Capacity
- 7200 rpm Performance
- Choice of SATA 6 Gbit/s or Dual-Port SAS 12 Gbit/s Interface
- 550 Total TB Transferred per Year Workload Rating<sup>[3]</sup>
- Choice of 512n or 512e (Advanced Format) Sector Technology
- Sanitize Instant Erase (SIE) and Self-Encrypting Drive (SED) Option Models Available

### APPLICATIONS

- Engineered for Mid-line / Nearline Business Critical Workloads
- Tier 2 Business-Critical Servers and Storage Systems
- Servers Supporting Workloads that Benefit from Higher Capacity per Spindle
- Capacity-Optimized Data Center Storage Systems
- IT infrastructure designed around Enterprise Capacity HDD performance
- Applications and hypervisors that require legacy 512 Native Sector Technology

Item	MG08ADA800A/AY(4Kn) MG08ADA800E/EY(512e) MG08ADP800A(4Kn) MG08ADP800E(512e)	MG08ADA600A/AY(4Kn) MG08ADA600E/EY(512e) MG08ADP600A(4Kn) MG08ADP600E(512e)	MG08ADA400A/AY(4Kn) MG08ADA400E/EY(512e) MG08ADA400N/NY(512n) MG08ADP400A(4Kn) MG08ADP400E(512e) MG08ADP400N(512n)	
Interface	SATA-3.3			
Formatted Capacity	8 TB	6 TB	4 TB	
Performance	Interface Speed <sup>[4]</sup>	6.0 Gbit/s, 3.0 Gbit/s, 1.5 Gbit/s		
	Rotation Speed	7200 rpm		
	Buffer Size	256 MiB <sup>[5]</sup>		
	Maximum Sustained Data Transfer Speed (Typ.)	4Kn/512e: 248 MiB/s	4Kn/512e: 239 MiB/s	4Kn/512e: 243 MiB/s 512n : 222 MiB/s
Logical Data Block Length	4Kn	4096 B		
	512e	Host:512 B, Disk:4096 B		
	512n	-	512 B	
Supply Voltage	Allowable Voltage 12 V <sup>[6]</sup> ± 10 % / 5 V <sup>[6]</sup> + 10% / -7% <sup>[7]</sup>			
Power Consumption	Write / Read 4KB Q1(Typ.)	9.29 W	8.50 W	7.76 W
	Active Idle (Idle-A) (Typ.)	5.61 W	4.90 W	4.07 W
Acoustics <sup>[8]</sup>	Active Idle (Typ.)	31 dB		

Item	MG08SDA800A/AY (4Kn) MG08SDA800E/EY (512e) MG08SDP800A(4Kn) MG08SDP800E(512e)	MG08SDA600A/AY (4Kn) MG08SDA600E/EY (512e) MG08SDP600A(4Kn) MG08SDP600E(512e)	MG08SDA400A/AY (4Kn) MG08SDA400E/EY (512e) MG08SDA400N/NY(512n) MG08SDP400A(4Kn) MG08SDP400E(512e) MG08SDP400N(512n)	
Interface	SAS-3			
Formatted Capacity	8 TB	6 TB	4 TB	
Performance	Interface Speed <sup>[4]</sup>	12.0 Gbit/s, 6.0 Gbit/s, 3.0 Gbit/s, 1.5 Gbit/s		
	Rotation Speed	7200 rpm		
	Buffer Size	256 MiB <sup>[5]</sup>		
	Maximum Sustained Data Transfer Speed (Typ.)	4Kn/512e: 248 MiB/s	4Kn/512e: 239 MiB/s	4Kn/512e: 243 MiB/s 512n : 222 MiB/s
Logical Data Block Length	4Kn	4096 B / 4160 B / 4224 B		
	512e	Host: 512 B Disk:4096 B / Host 520 B Disk:4160 B		
	512n	-	512 B / 520B	
Supply Voltage	Allowable Voltage 12 V <sup>[6]</sup> ± 10 % / 5 V <sup>[6]</sup> + 10% / -7% <sup>[7]</sup>			
Power Consumption	Write / Read 4KB Q1(Typ.)	9.72 W	9.03 W	8.16 W
	Active Idle (Idle-A) (Typ.)	6.06 W	5.39 W	4.50 W
Acoustics <sup>[8]</sup>	Active Idle (Typ.)	31 dB		

## ENVIRONMENTAL LIMITS

Item	Specification	
Ambient temperature	Operating	5 °C to 55 °C (No condensation)
	Non-Operating	-40 °C to 70 °C (No condensation)
Enclosure surface temperature	Operating	5 °C to 60 °C (No condensation)
Relative Humidity	Operating	5 % to 90 % R.H. (No condensation)
	Non-Operating	5 % to 95 % R.H. (No condensation)
Altitude	Operating	- 305 m to 3048 m
	Non-Operating	- 305 m to 12 192 m
Shock <sup>[9]</sup>	Operating	686 m/s <sup>2</sup> { 70 G } ( 2 ms duration )
	Non-Operating	2940 m/s <sup>2</sup> { 300 G } ( 2 ms duration ) 4TB 2450 m/s <sup>2</sup> { 250 G } ( 2 ms duration ) 8/6TB
Vibration <sup>[9]</sup>	Operating <sup>[10]</sup>	7.35 m/s <sup>2</sup> { 0.75 G } ( 5 to 300 Hz ) 2.45 m/s <sup>2</sup> { 0.25 G } ( 300 to 500 Hz )
	Non-Operating <sup>[11]</sup>	29.4 m/s <sup>2</sup> { 3.0 G } ( 5 to 500 Hz )

## RELIABILITY

Item	Specification
MTTF / AFR <sup>[12]</sup>	2 000 000 hours / 0.44 %
Non-recoverable Error Rate	10 error per 10 <sup>16</sup> bits read
Load / Unload	600 000 times
Availability	24 hours/day, 7 days/week
Rated Annual Workload	550 TB per year

[1] Definition of capacity: Toshiba defines a terabyte (TB) as 1 000 000 000 000 bytes. A computer operating system, however, reports storage capacity using powers of 2 for the definition of 1TB = 2<sup>40</sup> = 1 099 511 627 776 bytes and therefore shows less storage capacity. Available storage capacity (including examples of various media files) will vary based on file size, formatting, settings, software and operating system, such as Microsoft Operating System and/or pre-installed software applications, or media content. Actual formatted capacity may vary.

[2] "3.5-inch" mean the form factor of HDDs. They do not indicate drive's physical size.

[3] Workload is defined as the amount of data written, read or verified by commands from host system.

[4] The maximum sustained data rate and interface speed may be restricted to the response speed of host system and by transmission characteristics.  
1 Gbit/s = 1 000 000 000 bit/s. 1 MiB/s = 1 048 576 B/s

[5] A mebibyte (MiB) means 2<sup>20</sup>, or 1 048 576 bytes.

[6] Input voltages are specified at the HDD connector side, during HDD ready state.

[7] Make sure the value is not less than DC -0.3 V DC (less than -0.6 V, 0.1 ms) when turning on or off the power.

- [8] The measuring method is based on ISO 7779.
- [9] Vibration applied to the HDD is measured at near the mounting screw hole on the frame as much as possible.
- [10] At random seek write/read and default on retry setting with log sweep vibration.
- [11] At power-off state after installation
- [12] MTTF (Mean Time to Failure) of the HDDs during its life time is 2 000 000 hours and AFR (Annualized Failure Rate) is 0.44 %. (POH: 8760 hours per one year (24 hours per one day, 7 days per one week). Average HDA surface temperature:40°C or less, workloads: 550 TB/year, which is defined as the amount of data written, read or verified by commands from host system). Continual or sustained operation at case HDA surface temperature above 40°C may degrade product reliability.

## MODEL NUMBER

Model Number	Interface	Capacity	Sector Format	Optional Security
MG08ADA800A	SATA-3.3	8 TB	4Kn	
MG08ADA800E	SATA-3.3	8 TB	512e <sup>[13]</sup>	
MG08ADA800AY	SATA-3.3	8 TB	4Kn	SIE
MG08ADA800EY	SATA-3.3	8 TB	512e <sup>[13]</sup>	SIE
MG08ADP800A	SATA-3.3	8 TB	4Kn	SED
MG08ADP800E	SATA-3.3	8 TB	512e <sup>[13]</sup>	SED
MG08SDA800A	SAS-3.0	8 TB	4Kn	
MG08SDA800E	SAS-3.0	8 TB	512e <sup>[13]</sup>	
MG08SDA800AY	SAS-3.0	8 TB	4Kn	SIE
MG08SDA800EY	SAS-3.0	8 TB	512e <sup>[13]</sup>	SIE
MG08SDP800A	SAS-3.0	8 TB	4Kn	SED
MG08SDP800E	SAS-3.0	8 TB	512e <sup>[13]</sup>	SED
MG08ADA600A	SATA-3.3	6 TB	4Kn	
MG08ADA600E	SATA-3.3	6 TB	512e <sup>[13]</sup>	
MG08ADA600AY	SATA-3.3	6 TB	4Kn	SIE
MG08ADA600EY	SATA-3.3	6 TB	512e <sup>[13]</sup>	SIE
MG08ADP600A	SATA-3.3	6 TB	4Kn	SED
MG08ADP600E	SATA-3.3	6 TB	512e <sup>[13]</sup>	SED
MG08SDA600A	SAS-3.0	6 TB	4Kn	
MG08SDA600E	SAS-3.0	6 TB	512e <sup>[13]</sup>	
MG08SDA600AY	SAS-3.0	6 TB	4Kn	SIE
MG08SDA600EY	SAS-3.0	6 TB	512e <sup>[13]</sup>	SIE
MG08SDP600A	SAS-3.0	6 TB	4Kn	SED
MG08SDP600E	SAS-3.0	6 TB	512e <sup>[13]</sup>	SED
MG08ADA400A	SATA-3.3	4 TB	4Kn	
MG08ADA400E	SATA-3.3	4 TB	512e <sup>[13]</sup>	
MG08ADA400N	SATA-3.3	4 TB	512n	
MG08ADA400AY	SATA-3.3	4 TB	4Kn	SIE
MG08ADA400EY	SATA-3.3	4 TB	512e <sup>[13]</sup>	SIE
MG08ADA400NY	SATA-3.3	4 TB	512n	SIE
MG08ADP400A	SATA-3.3	4 TB	4Kn	SED
MG08ADP400E	SATA-3.3	4 TB	512e <sup>[13]</sup>	SED
MG08ADP400N	SATA-3.3	4 TB	512n	SED
MG08SDA400A	SAS-3.0	4 TB	4Kn	
MG08SDA400E	SAS-3.0	4 TB	512e <sup>[13]</sup>	
MG08SDA400N	SAS-3.0	4 TB	512n	
MG08SDA400AY	SAS-3.0	4 TB	4Kn	SIE
MG08SDA400EY	SAS-3.0	4 TB	512e <sup>[13]</sup>	SIE
MG08SDA400NY	SAS-3.0	4 TB	512n	SIE
MG08SDP400A	SAS-3.0	4 TB	4Kn	SED
MG08SDP400E	SAS-3.0	4 TB	512e <sup>[13]</sup>	SED
MG08SDP400N	SAS-3.0	4 TB	512n	SED

[13] Read-modify-write is supported.

## MARKING

### 1) WEEE

Following information is only for EU-member states:

The use of the symbol indicates that this product may not be treated as household waste. By ensuring this product is disposed of correctly, you will help prevent potential negative consequences for the environment and human health, which could otherwise be caused by inappropriate waste handling of this product. For more detailed information about recycling of this product, please contact your local city office, your household waste disposal service or the shop where you purchased the product.



### 2) Names and Contents of Hazardous Substances or Elements in Products

产品中有害物质的名称及含量

部件名称	有害物质					
	铅 (Pb)	汞 (Hg)	镉 (Cd)	六价铬 (Cr(VI))	多溴联苯 (PBB)	多溴二苯醚 (PBDE)
HDD(硬盘驱动器)	×	○	○	○	○	○

本表格依据 SJ/T 11364 的规定编制。  
 ○: 表示该有害物质在该部件所有均质材料中的含量均在 GB/T 26572 规定的限量要求以下。  
 ×: 表示该有害物质至少在该部件的某一均质材料中的含量超出 GB/T 26572 规定的限量要求。



中华人民共和国环保使用期限

## SAFETY / EMI STANDARDS

Title	Region
UL (Underwriters Laboratories)	USA
CSA (Canadian Standard Association)	Canada
TÜV (Technischer Überwachungs Verein)	Germany
BSMI (Bureau of Standards, Metrology and Inspection)	Taiwan
KC (Note 1) (Korea Certification)	Korea
RCM (Regulatory Compliance Mark)	Australia and New Zealand

(Note) Marks of KC

Made in Japan		1. 기기의 명칭(모델명) : MG08ADA800/600 A/E/AY/EY, MG08ADP800/600 A/E	
		2. 인증번호 : R-R-T48-MG08ADA400N	
		3. 인증받은 자의 상호 : TOSHIBA ELECTRONIC DEVICES & STORAGE CORPORATION	
		4. 제조년월일 : 2019-01	/ 일본
Made in Japan		1. 기기의 명칭(모델명) : MG08SDA800/600 A/E/AY/EY, MG08SDP800/600 A/E	
		2. 인증번호 : R-R-T48-MG08SDA400N	
		3. 인증받은 자의 상호 : TOSHIBA ELECTRONIC DEVICES & STORAGE CORPORATION	
		4. 제조년월일 : 2019-01	/ 일본
Made in Japan		1. 기기의 명칭(모델명) : MG08ADA400 A/E/N/AY/EY/NY, MG08ADP400 A/E/N	
		2. 인증번호 : R-R-T48-MG08ADA400N	
		3. 인증받은 자의 상호 : TOSHIBA ELECTRONIC DEVICES & STORAGE CORPORATION	
		4. 제조년월일 : 2019-01	/ 일본
Made in Japan		1. 기기의 명칭(모델명) : MG08SDA400 A/E/N/AY/EY/NY, MG08SDP400 A/E/N	
		2. 인증번호 : R-R-T48-MG08SDA400N	
		3. 인증받은 자의 상호 : TOSHIBA ELECTRONIC DEVICES & STORAGE CORPORATION	
		4. 제조년월일 : 2019-01	/ 일본
Made in Philippines		1. 기기의 명칭(모델명) : MG08ADA800/600 A/E/AY/EY, MG08ADP800/600 A/E	
		2. 인증번호 : R-R-T48-MG08ADA400N	
		3. 인증받은 자의 상호 : TOSHIBA ELECTRONIC DEVICES & STORAGE CORPORATION	
		4. 제조년월일 : 2019-01	/ 필리핀
Made in Philippines		1. 기기의 명칭(모델명) : MG08SDA800/600 A/E/AY/EY, MG08SDP800/600 A/E/	
		2. 인증번호 : R-R-T48-MG08SDA400N	
		3. 인증받은 자의 상호 : TOSHIBA ELECTRONIC DEVICES & STORAGE CORPORATION	
		4. 제조년월일 : 2019-01	/ 필리핀
Made in Philippines		1. 기기의 명칭(모델명) : MG08ADA400 A/E/N/AY/EY/NY, MG08ADP400 A/E/N	
		2. 인증번호 : R-R-T48-MG08ADA400N	
		3. 인증받은 자의 상호 : TOSHIBA ELECTRONIC DEVICES & STORAGE CORPORATION	
		4. 제조년월일 : 2019-01	/ 필리핀
Made in Philippines		1. 기기의 명칭(모델명) : MG08SDA400 A/E/N/AY/EY/NY, MG08SDP400 A/E/N	
		2. 인증번호 : R-R-T48-MG08SDA400N	
		3. 인증받은 자의 상호 : TOSHIBA ELECTRONIC DEVICES & STORAGE CORPORATION	
		4. 제조년월일 : 2019-01	/ 필리핀

B 급 기기  
(가정용 방송통신기자재)

이 기기는 가정용 (B 급) 전자파 적합 기기로서 주로 가정에서 사용하는 것을 목적으로 하며, 모든 지역에서 사용할 수 있습니다.

## MECHANICAL SPECIFICATIONS

Item	Specification		
	8TB	6TB	4TB
Capacity			
Width (Max)	101.85 mm		
Height (Max)	26.1 mm		
Length (Max)	147.0 mm		
Weight (Max. (Typ))	720 g (700 g)	700 g (680 g)	693 g (675 g)

MG08ADAx<sub>xx</sub>A/E  
 MG08ADAx<sub>xx</sub>AY/EY  
 MG08ADP<sub>xx</sub>A/E  
 (XXX = 800/600)

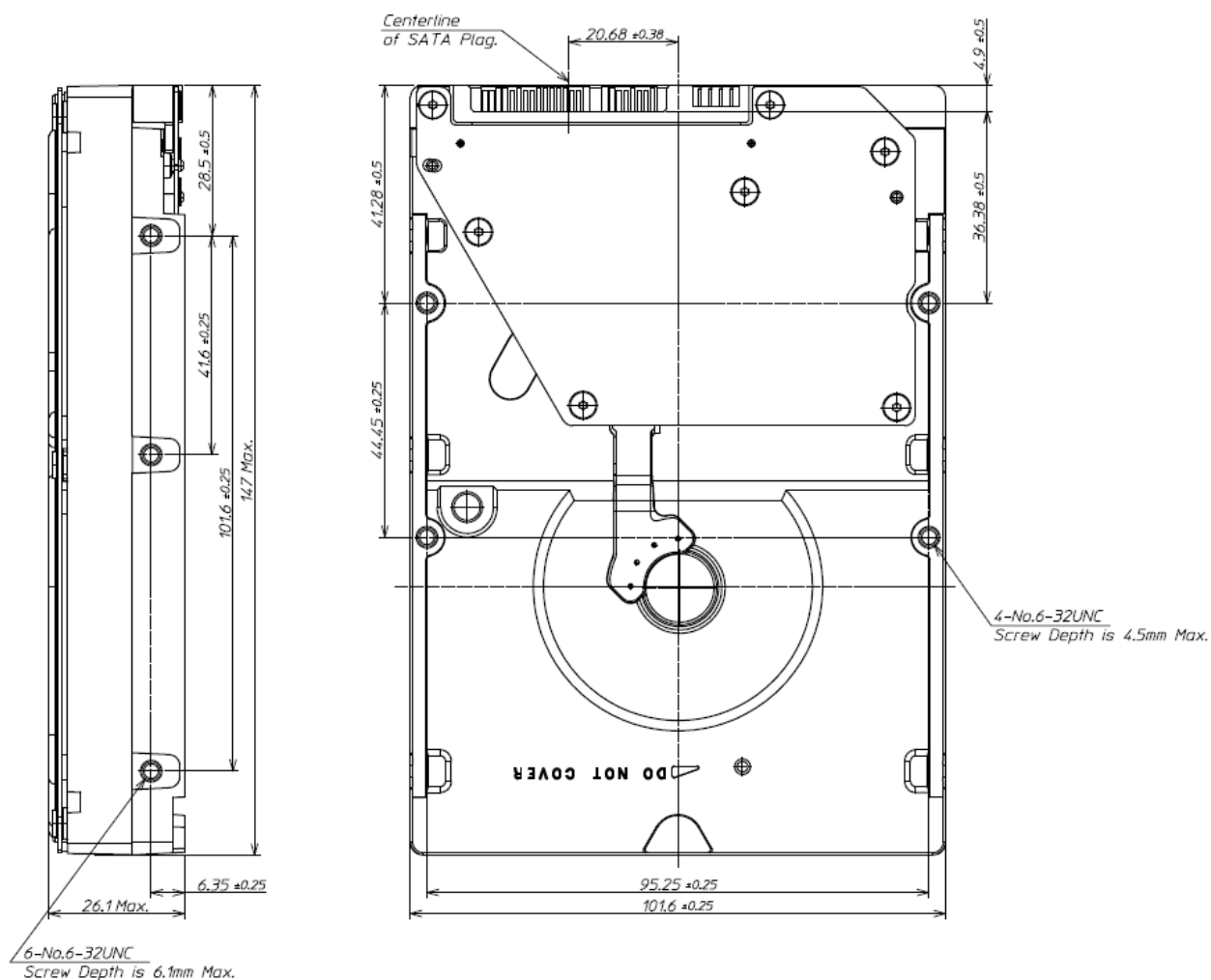
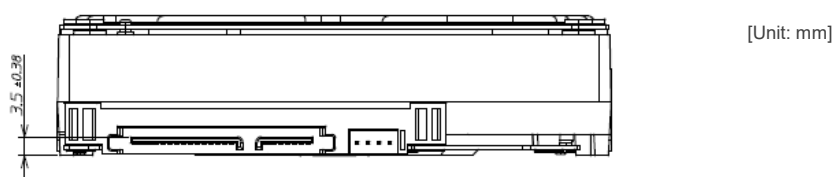

MG08ADA400A/E/N  
 MG08ADA400AY/EY/NY  
 MG08ADP400A/E/N

[Unit: mm]

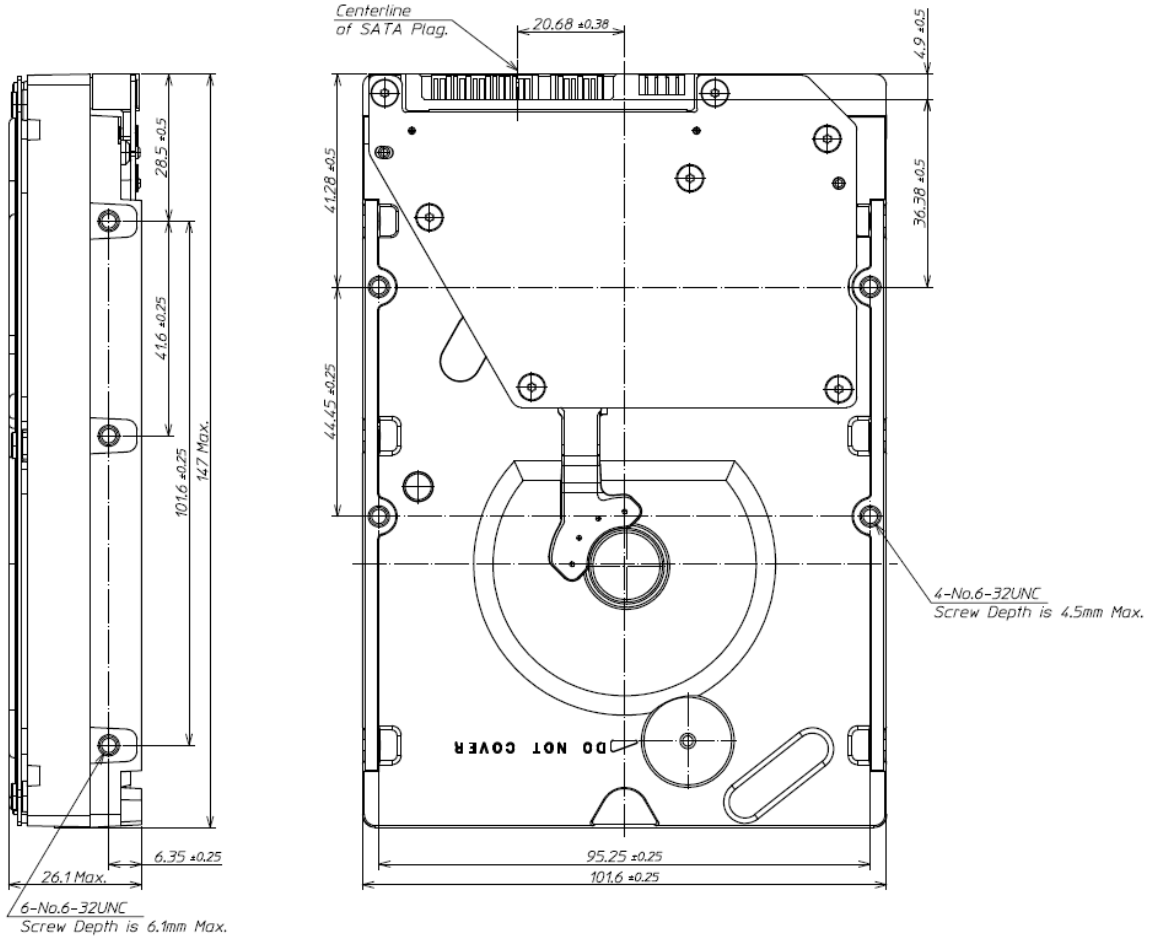
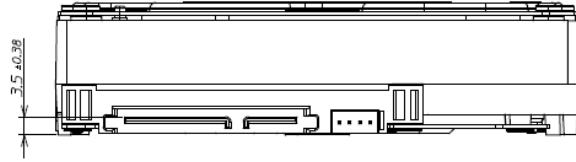



MG08SDAxxxA/E/N  
 MG08SDAxxxAY/EY/NY  
 MG08SDPxxxA/E/N  
 (XXX = 800/600)

[Unit: mm]

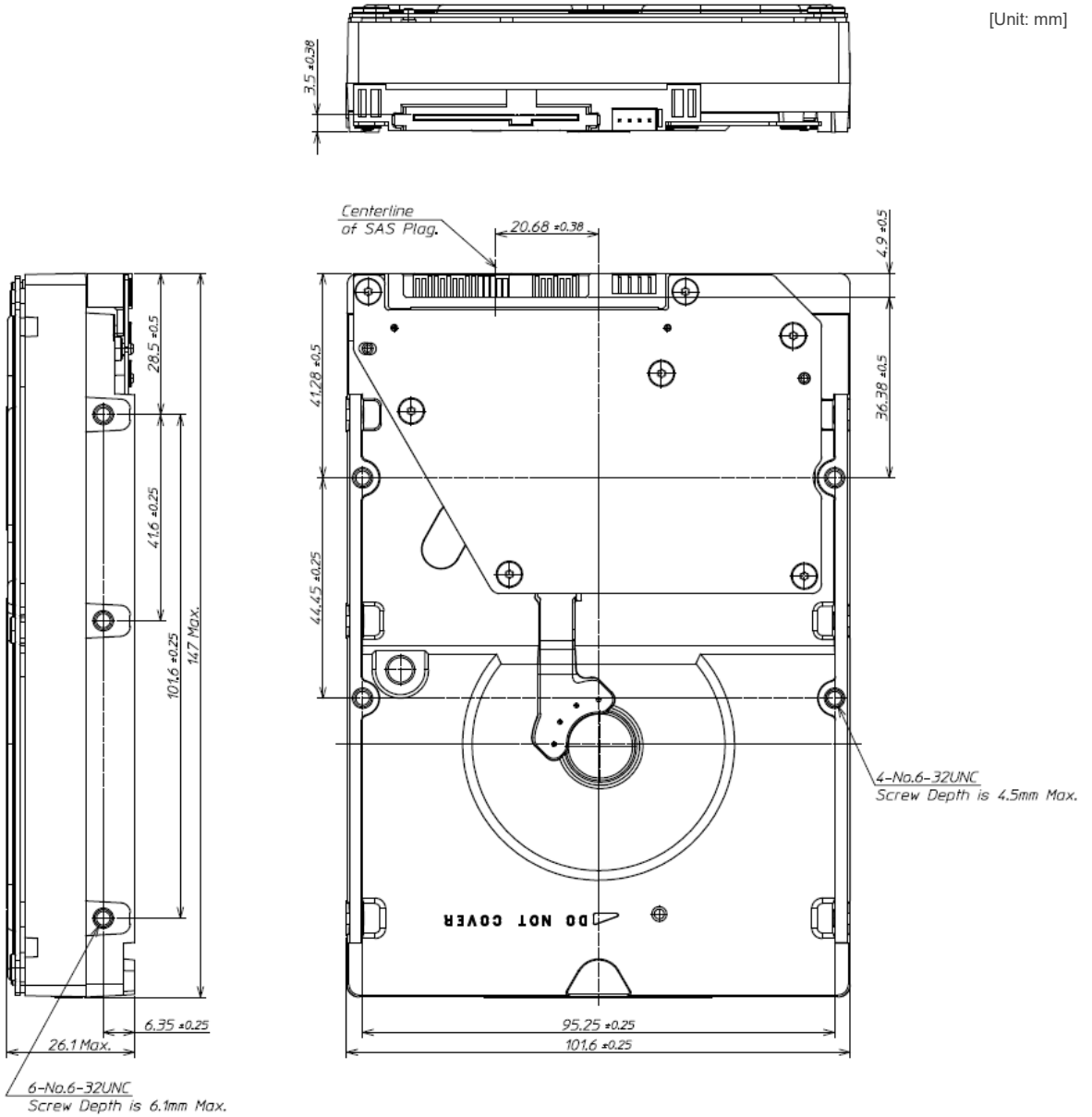

MG08SDA400A/E/N  
 MG08SDA400AY/EY/NY  
 MG08SDP400A/E/N

[Unit: mm]

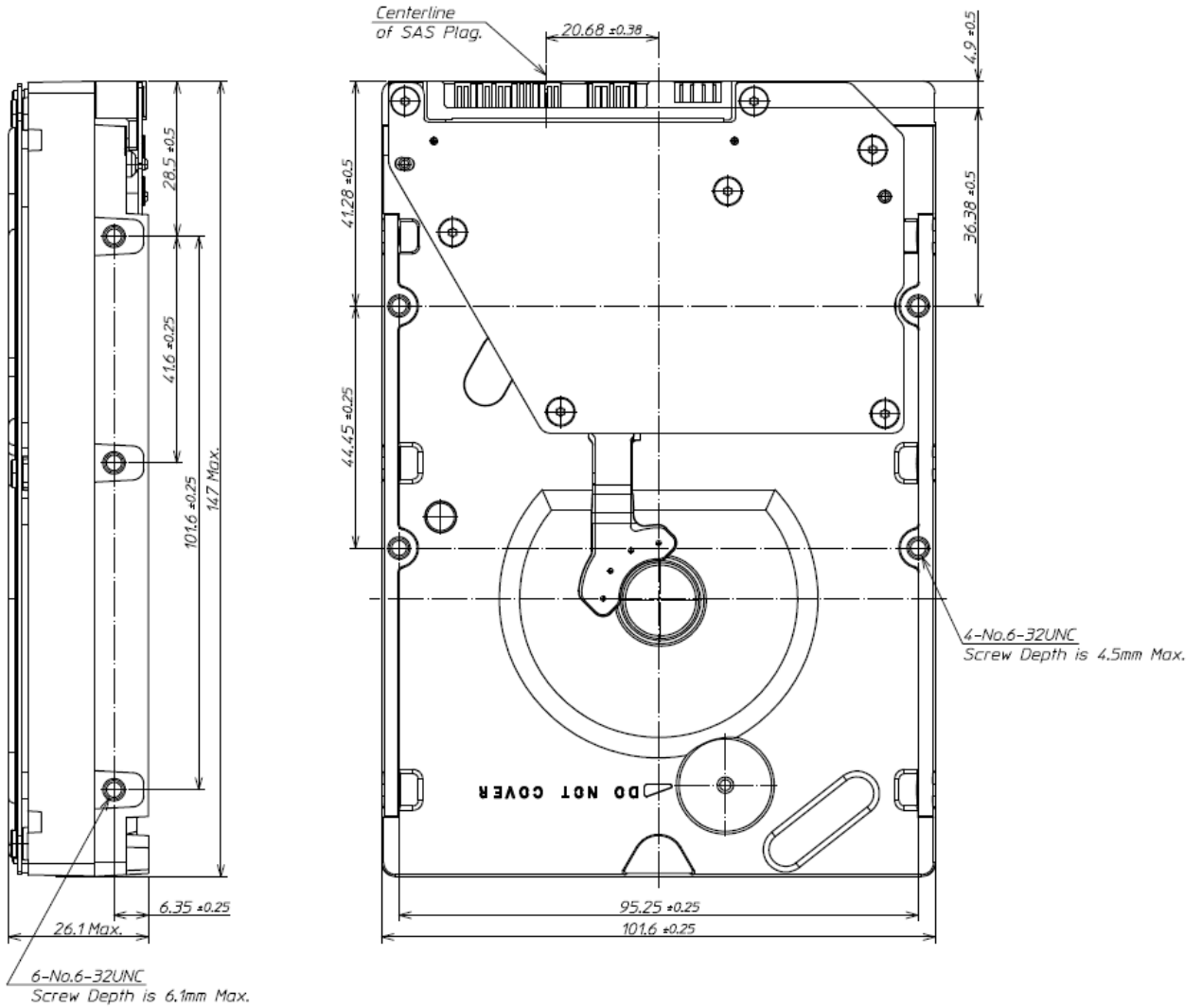
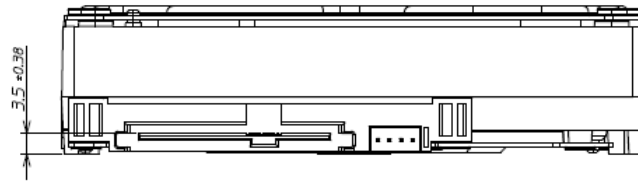

# INTERFACE CONNECTOR

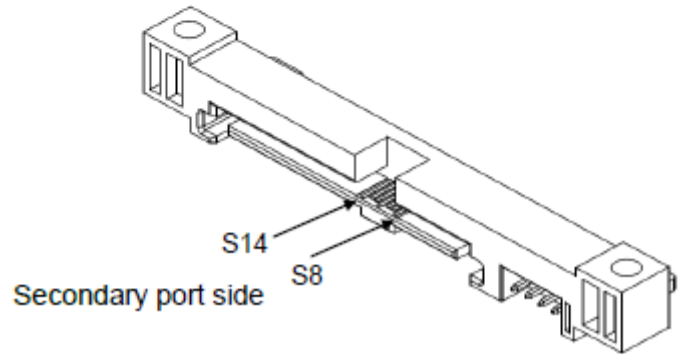
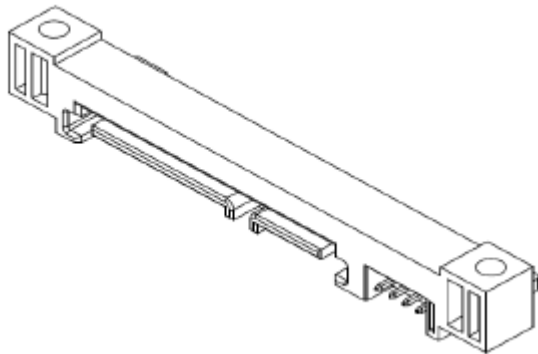
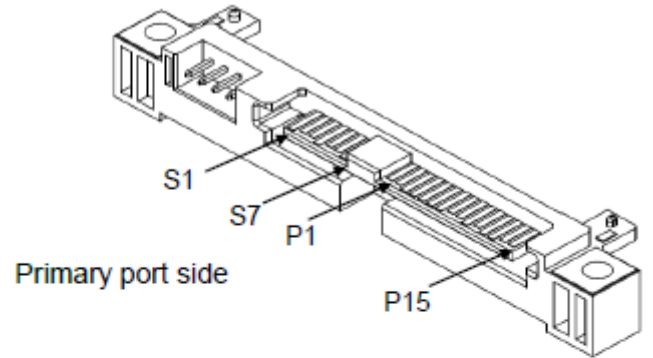
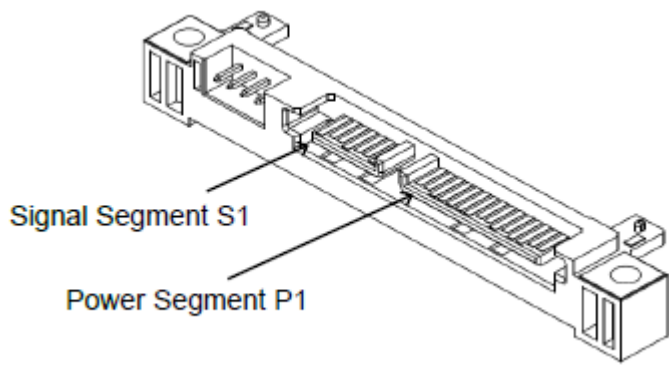

**SATA plug connector overview**  
MG08ADAxxxA/E/N  
MG08ADAxxxAY/EY/NY  
MG08ADPxxxA/E/N

**SAS plug connector overview**  
MG08SDAxxxA/E/N  
MG08SDAxxxAY/EY/NY  
MG08SDPxxxA/E/N

**INTERFACE CONNECTOR (SATA plug) SIGNAL ALLOCATION**  
 (MG08ADAxxxA/E/N, MG08ADAxxxAY/EY/NY, MG08ADPxxxA/E/N)

Segment	Pin No.	Pin Definition	
Signal Segment	S1	GND	2 <sup>nd</sup> Mate
	S2	A+	Differential Pair A from PHY (Device Rx+)
	S3	A-	Differential Pair A from PHY (Device Rx-)
	S4	GND	2 <sup>nd</sup> Mate
	S5	B-	Differential Pair B from PHY (Device Tx-)
	S6	B+	Differential Pair B from PHY (Device Tx+)
	S7	GND	2 <sup>nd</sup> Mate
Power Segment	P1	—	(Unused)
	P2	—	(Unused)
	P3	PWDIS	Enter/Exit Power Disable (Option)
	P4	GND	1 <sup>st</sup> Mate
	P5	GND	2 <sup>nd</sup> Mate
	P6	GND	2 <sup>nd</sup> Mate
	P7	V5	5 V Power Pre-Charge 2 <sup>nd</sup> Mate
	P8	V5	5 V Power
	P9	V5	5 V Power
	P10	GND	2 <sup>nd</sup> Mate
	P11	Spin	- Staggered Spin-up Mode Detect (Input)
		ACT	- Activity LED Drive (Output)
	P12	GND	1 <sup>st</sup> Mate
	P13	V12	12 V Power Pre-Charge 2 <sup>nd</sup> Mate
	P14	V12	12 V Power
P15	V12	12 V Power	

Notice: This drive uses 5 V and 12 V power. 3.3 V power is not used.  
 HDA (Head Disk Assembly) and DC ground (ground pins on interface) are connected electrically each other.

**INTERFACE CONNECTOR (SAS plug) SIGNAL ALLOCATION**  
**(MG08SDAxxxA/E/N, MG08SDAxxxAY/EY/NY, MG08SDPxxxA/E/N)**

Segment	Pin No.		Pin Definition
Signal Segment	S1	GND	GND for SAS Primary Port
	S2	RP+	SAS Primary Port Receive (positive) signal
	S3	RP-	SAS Primary Port Receive (negative) signal
	S4	GND	GND for SAS Primary Port
	S5	TP-	SAS Primary Port Transmit (negative) signal
	S6	TP+	SAS Primary Port Transmit (positive) signal
	S7	GND	GND for SAS Primary Port
	S8	GND	GND for SAS Secondary Port
	S9	RS+	SAS Secondary Port Receive (positive) signal
	S10	RS-	SAS Secondary Port Receive (negative) signal
	S11	GND	GND for SAS Secondary Port
	S12	TS-	SAS Secondary Port Transmit (negative) signal
	S13	TS+	SAS Secondary Port Transmit (positive) signal
	S14	GND	GND for SAS Secondary Port
Power Segment	P1 (*1)	Reserved	Do not supply 3.3 V power if POWER DISABLE Function is used.
	P2 (*1)	Reserved	
	P3 (*2)	POWER DISABLE	Power Disable Control input signal
	P4	GND	GROUND
	P5	GND	GROUND
	P6	GND	GROUND
	P7	+5 V-Charge	Pre-charge pin for +5 V
	P8	+5 V	+5 V power supply input
	P9	+5 V	+5 V power supply input
	P10	GND	GROUND
	P11	READY LED	READY LED output
	P12	GND	GROUND
	P13	+12 V-Charge	Pre-charge pin for +12 V
	P14	+12 V	+12 V power supply input
	P15	+12 V	+12 V power supply input

(\*1) Do not supply 3.3 V power if POWER DISABLE feature is used.

(\*2) The terminal P3 is used as POWER DISABLE control signal in SAS-3. This terminal connects with the GROUND or is an OPENED thing on the host side when the POWER DISABLE function is not used.

**SATA COMMAND TABLE (Part 1)**  
(MG08ADAxxxA/E/N, MG08ADAxxxAY/EY/NY, MG08ADPxxxA/E/N)

Op-Code	Command Name
78h	ACCESSIBLE MAX ADDRESS CONFIGURATION
E5h/98h	CHECK POWER MODE
92h	DOWNLOAD MICROCODE
93h	DOWNLOAD MICROCODE DMA
90h	EXECUTE DIAGNOSTICS
E7h	FLUSH CACHE
EAh	FLUSH CACHE EXT
ECh	IDENTIFY DEVICE
E3h/97h	IDLE
E1h/95h	IDLE IMMEDIATE
91h	INITIALIZE DEVICE PARAMETERS
00h	NOP
E4h	READ BUFFER
C8h	READ DMA
25h	READ DMA EXT
60h	READ FPDMA QUEUED
2Fh	READ LOG EXT
47h	READ LOG DMA EXT
C4h	READ MULTIPLE
29h	READ MULTIPLE EXT
20h	READ SECTOR(S)
24h	READ SECTOR(S) EXT
40h	READ VERIFY SECTOR(S)
42h	READ VERIFY SECTOR(S) EXT

## SATA COMMAND TABLE (Part 2)

(MG08ADAxxxA/E/N, MG08ADAxxxAY/EY/NY, MG08ADPxxxA/E/N)

Op-Code	Command Name
1xh	RECALIBRATE
0Bh	REQUEST SENSE DATA EXT
B4h	SANITIZE DEVICE
F1h	SECURITY SET PASSWORD
F2h	SECURITY UNLOCK
F3h	SECURITY ERASE PREPARE
F4h	SECURITY ERASE UNIT
F5h	SECURITY FREEZE LOCK
F6h	SECURITY DISABLE PASSWORD
70h – 76h, 79h – 7Fh	SEEK
77h	SET DATE & TIME EXT
EFh	SET FEATURES
C6h	SET MULTIPLE MODE
E6h/99h	SLEEP
B0h	SMART Function Set
E2h/96h	STANDBY
E0h/94h	STANDBY IMMEDIATE
E8h	WRITE BUFFER
CAh	WRITE DMA
35h	WRITE DMA EXT
3Dh	WRITE DMA FUA EXT
61h	WRITE FPDMA QUEUED
3Fh	WRITE LOG EXT
57h	WRITE LOG DMA EXT
C5h	WRITE MULTIPLE
39h	WRITE MULTIPLE EXT
CEh	WRITE MULTIPLE FUA EXT
30h	WRITE SECTOR(S)
34h	WRITE SECTOR(S) EXT
45h	WRITE UNCORRECTABLE EXT
3Ch	WRITE VERIFY

## SAS COMMAND TABLE (Part 1)

(MG08SDAxxxA/E/N, MG08SDAxxxAY/EY/NY, MG08SDPxxxA/E/N)

Op-Code	Command Name
00h	TEST UNIT READY
12h	INQUIRY
25h	READ CAPACITY (10)
9Eh/10h	READ CAPACITY (16)
15h	MODE SELECT (6)
55h	MODE SELECT (10)
1Ah	MODE SENSE (6)
5Ah	MODE SENSE (10)
01h	REZERO UNIT
1Bh	START/STOP UNIT
16h	RESERVE (6)
56h	RESERVE (10)
17h	RELEASE (6)
57h	RELEASE (10)
03h	REQUEST SENSE
4Ch	LOG SELECT
4Dh	LOG SENSE
5Eh	PERSISTENT RESERVE IN
5Fh	PERSISTENT RESERVE OUT
A0h	REPORT LUNS
A3h/05h	REPORT IDENTIFYING INFORMATION
A3h/0Ch	REPORT SUPPORTED OPERATION CODES
A3h/0Dh	REPORT SUPPORTED TASK MANAGEMENT FUNCTIONS
A4h/06h	SET IDENTIFYING INFORMATION
A3h/0Fh	REPORT TIMESTAMP
A4h/0Fh	SET TIMESTAMP



## SAS COMMAND TABLE (Part 2)

(MG08SDAxxxA/E/N, MG08SDAxxxAY/EY/NY, MG08SDPxxxA/E/N)

Op-Code	Command Name
08h	READ (6)
28h	READ (10)
A8h	READ (12)
88h	READ (16)
0Ah	WRITE (6)
2Ah	WRITE (10)
AAh	WRITE (12)
8Ah	WRITE (16)
2Eh	WRITE AND VERIFY (10)
AEh	WRITE AND VERIFY (12)
8Eh	WRITE AND VERIFY (16)
2Fh	VERIFY (10)
AFh	VERIFY (12)
8Fh	VERIFY (16)
0Bh	SEEK (6)
2Bh	SEEK (10)
35h	SYNCHRONIZE CACHE (10)
91h	SYNCHRONIZE CACHE (16)
04h	FORMAT UNIT
07h	REASSIGN BLOCKS
37h	READ DEFECT DATA (10)
B7h	READ DEFECT DATA (12)
1Dh	SEND DIAGNOSTIC
1Ch	RECEIVE DIAGNOSTIC RESULTS
3Bh	WRITE BUFFER
3Ch	READ BUFFER (10)
9Bh	READ BUFFER (16)
3Eh	READ LONG (10)
9Eh/11h	READ LONG (16)
3Fh	WRITE LONG (10)
9Fh/11h	WRITE LONG (16)
41h	WRITE SAME (10)
93h	WRITE SAME (16)
48h	SANITIZE (10)