

Features

- 14 Different Configurations
- Beam Lead, Flip Chip, or Packaged Devices
- Hi-Rel Screening per MIL-PRF-19500 and MIL-PRF-38534 Available

Description

The MGS series of GaAs Schottky diodes are designed for optimum performance in millimeter wave components operating to 60 GHz.

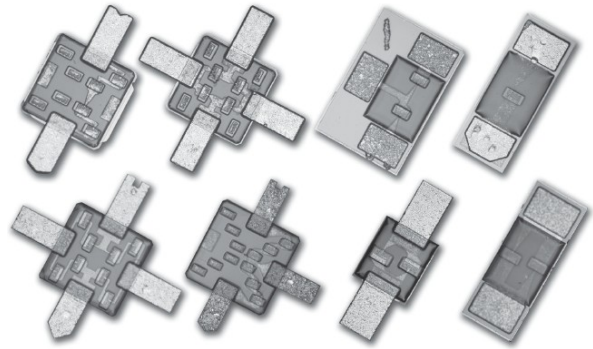

Beam Lead

Electrical Characteristics, $T_A = +25^\circ\text{C}$

Model	Configuration	V_F mV		ΔV_F mV	V_{BR} V	C_J pF	ΔC_J pF	R_S	Outline	
		Min.	Max.	Max.	Min.	Max.	Max.	Max.		
MGS901	Single Junction	650	750	—	5	0.06	—	7	GB110	
MGS902	Anti-parallel Pair	650	750	20	5	0.10	—	7	GB210	
MGS903	Series Tee	650	750	20	5	0.06	0.02	7	GB310	
MGS904	4 Junction Ring-Quad	650	750	20	5	0.06	0.02	7	B85	
MGS905	4 Junction Bridge-Quad	650	750	20	5	0.06	0.02	7	B86	
MGS906	4 Junction Series-Tee	1300	1500	40	10	0.04	0.02	14	B91	
MGS907	8 Junction Ring-Quad	1300	1500	40	10	0.04	0.02	14	B85	
MGS907A	8 Junction Ring-Quad	1300	1500	40	10	0.06	0.02	12	B85	
MGS907B	8 Junction Ring-Quad	1300	1500	40	10	0.08	0.02	10	B85	
MGS908	8 Junction Quad	1300	1500	40	10	0.04	0.02	14	B86	
MGS909	6 Junction Series-Tee	1800	2100	60	15	0.10	0.03	21	B90	
MGS910	12 Junction Ring-Quad	1800	2100	60	15	0.10	0.03	21	B87	
MGS911	12 Junction Bridge-Quad	1800	2100	60	15	0.10	0.03	21	B88	
MGS912	Four Junction	2500	2900	—	20	0.03	—	28	B89	
Test Conditions		$I_F = 1 \text{ mA}$			$I_R = 10 \mu\text{A}$	$V_R = 0 \text{ V}, 1 \text{ MHz}$	$I_F = 5 \text{ mA}$			

Flip Chip

Electrical Characteristics, $T_A = +25^\circ\text{C}$

Model	Configuration	V_F mV		ΔV_F mV	V_{BR} V	C_J pF	ΔC_J pF	R_S	Outline	
		Min.	Max.	Max.	Min.	Max.	Max.	Max.		
MGS801	Single Junction	650	750	—	5	0.05	—	7	GC110	
MGS801A	Single Junction	650	750	—	5	0.075	—	5	GC110	
MGS802	Anti-parallel Pair	650	750	20	5	0.10	—	7	GC210	
MGS802A	Anti-parallel Pair	650	750	20	5	0.15	—	5	GC210	
MGS803	Series Tee	650	750	20	5	0.06	0.02	7	GC310	
Test Conditions		$I_F = 1 \text{ mA}$			$I_R = 10 \mu\text{A}$	$V_R = 0 \text{ V}, 1 \text{ MHz}$	$I_F = 5 \text{ mA}$			

Absolute Maximum Ratings

Rating	Limits
Reverse Voltage	Rated Vbr
Forward Current	50 mA
DC Power Dissipation	75 mW per junction @ $T_A = 25^\circ\text{C}$
Operating Temperature	-65°C to $+150^\circ\text{C}$
Storage Temperature	-65°C to $+150^\circ\text{C}$
Soldering Temperature (packaged)	$+260^\circ\text{C}$ for 5 seconds per JEDEC J-STD-20C
Minimum Beam Lead Pull Strength	6 grams

Outlines

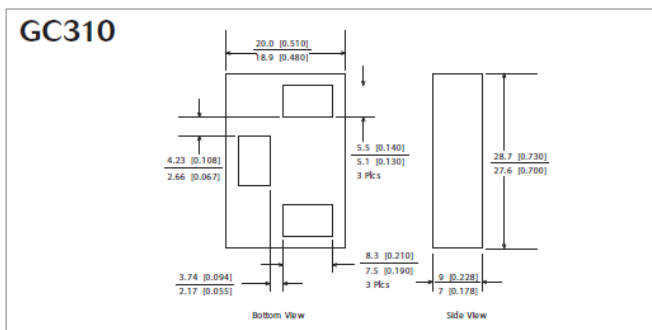
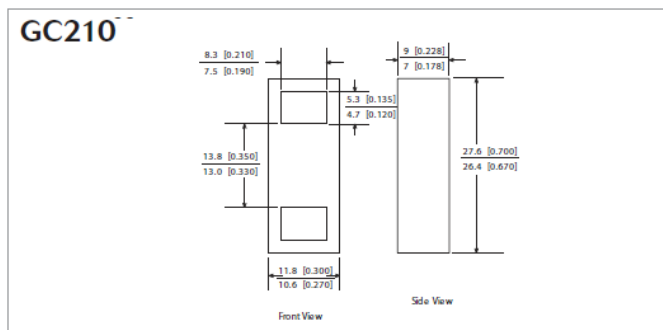
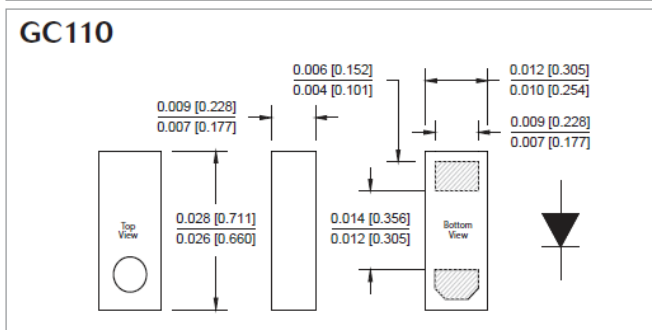
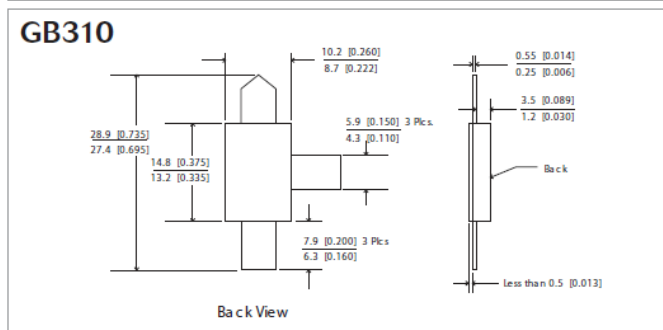
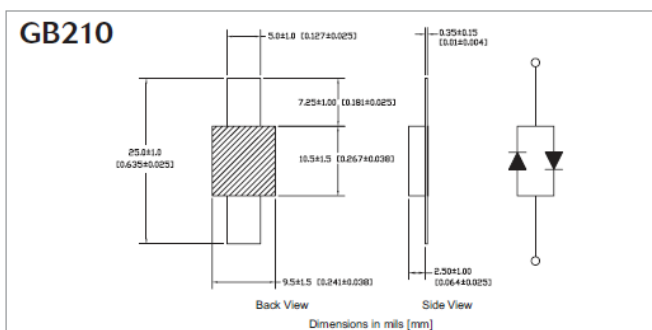
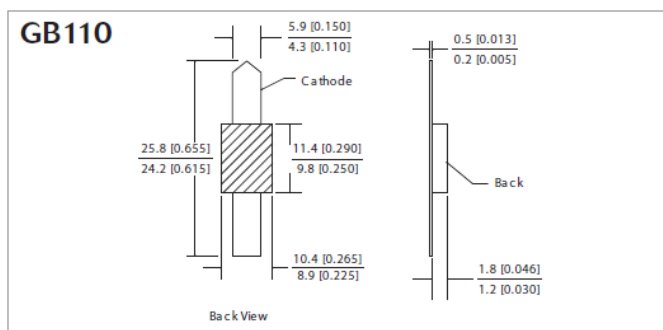

Outlines

