

General Description

The MIC2560 V_{CC} and V_{PP} Matrix controls PCMCIA (Personal Computer Memory Card International Association) memory card power supply pins, both V_{CC} and V_{PP} . The MIC2560 switches voltages from the system power supply to V_{CC} and V_{PP} . The MIC2560 switches between the three V_{CC} voltages (OFF, 3.3V and 5.0V) and the V_{PP} voltages (OFF, 0V, 3.3V, 5V, or 12.0V) required by PCMCIA cards. Output voltage is selected by two digital inputs for each output and output current ranges up to 1A for V_{CC} and 200mA for V_{PP} .

The MIC2560 provides power management capability under the control of the PC Card controller and features over current and thermal protection of the power outputs, zero current "sleep" mode, suspend mode, low power dynamic mode, and on-off control of the PCMCIA socket power.

The MIC2560 is designed for efficient operation. In stand-by (sleep) mode the device draws very little quiescent current, typically 0.01 μ A. The device and PCMCIA ports are protected by current limiting and overtemperature shutdown. Full cross-conduction lockout protects the system power supply.

Data sheets and support documentation can be found on Micrel's web site at www.micrel.com.

Features

- Complete PCMCIA V_{CC} and V_{PP} switch matrix in a single IC
- No external components required
- Logic compatible with industry standard PCMCIA controllers
- No voltage overshoot or switching transients
- Break-before-make switching
- Output current limit and overtemperature shutdown
- Digital flag for error condition indication
- Ultra-low power consumption
- Digital selection of V_{CC} and V_{PP} voltages
- Over 1A V_{CC} output current
- 200mA V_{PP} (12V) output current
- Options for direct compatibility with industry standard PCMCIA controllers
- 16-Pin SOIC package

Applications

- PCMCIA power supply pin voltage switch
- Font cards for printers and scanners
- Data-collection systems
- Machine control data input systems
- Wireless communications
- Bar code data collection systems
- Instrumentation configuration/data-logging
- Docking stations (portable and desktop)
- Power supply management
- Power analog switching

Typical Application

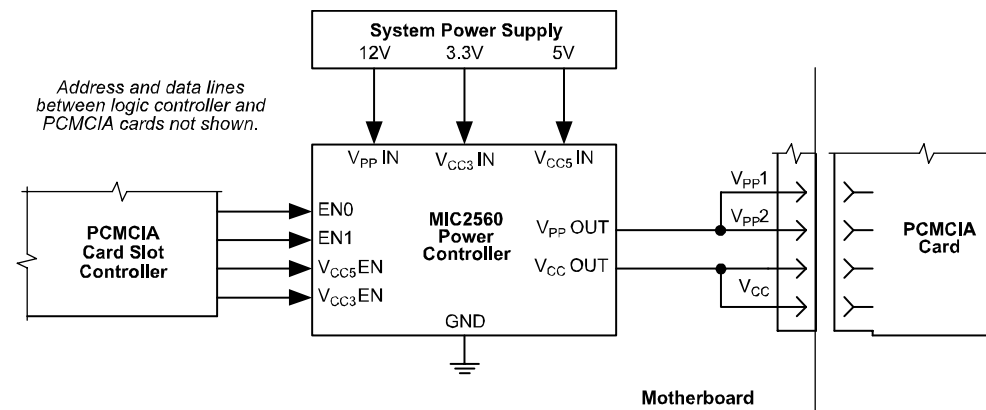

Ordering Information

Part Number		Temperature Range	Package
Standard	Pb-Free		
MIC2560-0BWM	MIC2560-0YWM	-40°C to +85°C	16-Pin Wide SOIC
MIC2560-1BWM	MIC2560-1YWM	-40°C to +85°C	16-Pin Wide SOIC

Pin Configuration

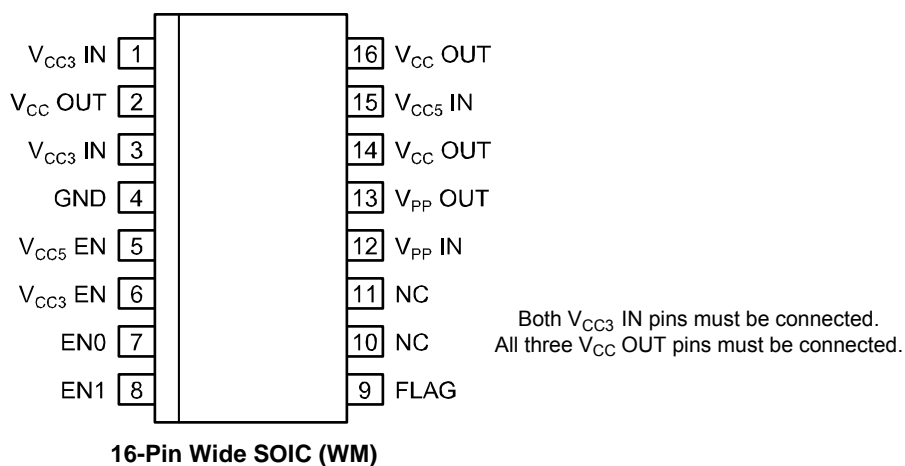

Logic Block Diagram

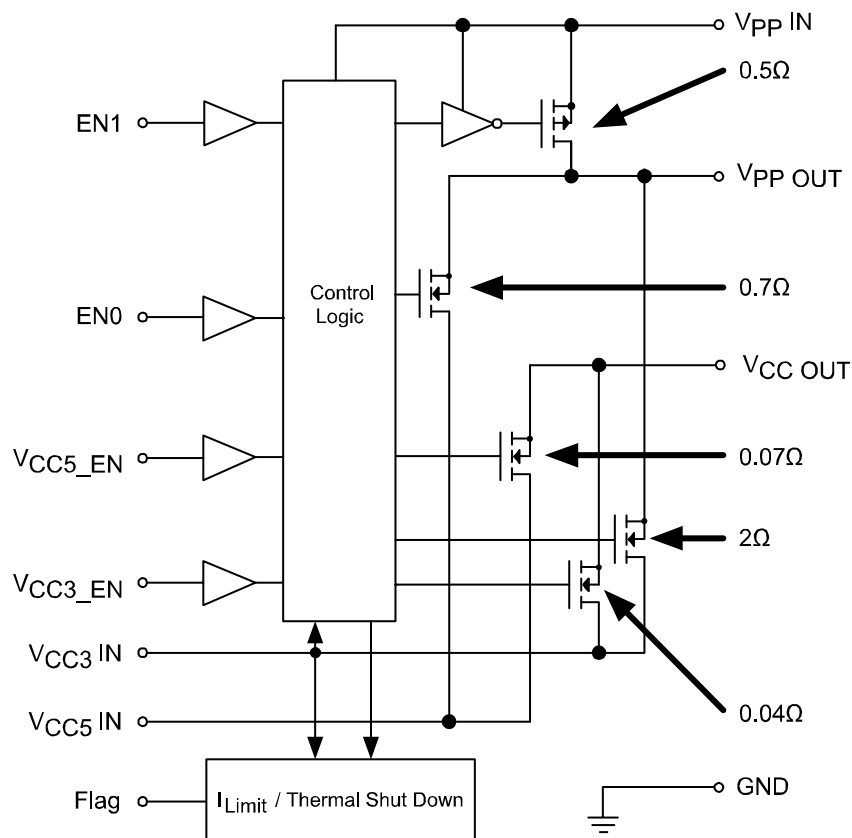

MIC2560-0 Control Logic Table

Pin 5 V _{CC5_EN}	Pin 6 V _{CC3_EN}	Pin 8 EN1	Pin 7 EN0	Pins 2 & 14 V _{CC} OUT	Pin 13 V _{PP} OUT
0	0	0	0	High Z	High Z
0	0	0	1	High Z	High Z
0	0	1	0	High Z	High Z
0	0	1	1	High Z	Clamped to Ground
0	1	0	0	3.3	High Z
0	1	0	1	3.3	3.3
0	1	1	0	3.3	12
0	1	1	1	3.3	Clamped to Ground
1	0	0	0	5	High Z
1	0	0	1	5	5
1	0	1	0	5	12
1	0	1	1	5	Clamped to Ground
1	1	0	0	3.3	High Z
1	1	0	1	3.3	3.3
1	1	1	0	3.3	5
1	1	1	1	3.3	Clamped to Ground

MIC2560-1 Logic (Compatible with Cirrus Logic CL-PD6710 & CL-PD6720 Controllers)

Pin 5 V _{CC5_EN}	Pin 6 V _{CC3_EN}	Pin 8 EN1	Pin 7 EN0	Pins 2 & 14 V _{CC} OUT	Pin 13 V _{PP} OUT
0	0	0	0	High Z	Clamped to Ground
0	0	0	1	High Z	High Z
0	0	1	0	High Z	High Z
0	0	1	1	High Z	High Z
0	1	0	0	5	Clamped to Ground
0	1	0	1	5	5
0	1	1	0	5	12
0	1	1	1	5	High Z
1	0	0	0	3.3	Clamped to Ground
1	0	0	1	3.3	3.3
1	0	1	0	3.3	12
1	0	1	1	3.3	High Z
1	1	0	0	High Z	Clamped to Ground
1	1	0	1	High Z	High Z
1	1	1	0	High Z	High Z
1	1	1	1	High Z	High Z

Absolute Maximum Ratings^(1, 2)

Power Dissipation, $T_{\text{AMBIENT}} \leq 25^{\circ}\text{C}$	<i>Internally Limited</i>
SOIC.....	800mW
Derating Factors (To Ambient)	
SOIC.....	4mW/ $^{\circ}\text{C}$
Storage Temperature (T_s).....	-65°C to $+150^{\circ}\text{C}$
Maximum Operating Temperature (Die).....	125°C
Operating Temperature (Ambient).....	-40°C to $+70^{\circ}\text{C}$
Lead Temperature (soldering, 5sec.).....	260°C

Supply Voltage ($V_{\text{PP IN}}$).....	15V
$V_{\text{CC3 IN}}$	$V_{\text{CC5 IN}}$
$V_{\text{CC5 IN}}$	7.5V
Logic Input Voltages.....	-0.3V to $+15\text{V}$
Output Current (each Output)	
$V_{\text{PP OUT}}$	$>200\text{mA}$, <i>Internally Limited</i>
$V_{\text{PP OUT}}$	$>1\text{A}$, <i>Internally Limited</i>
$V_{\text{PP OUT}}$, Suspend Mode.....	600mA

Electrical Characteristics⁽³⁾

(Over operating temperature range with $V_{\text{CC3 IN}} = 3.3\text{V}$, $V_{\text{CC5 IN}} = 5.0\text{V}$, $V_{\text{PP IN}} = 12\text{V}$ unless otherwise specified.)

Symbol	Parameter	Condition	Min	Typ	Max	Units
Input						
V_{IH}	Logic 1 Input Voltage		2.2		15	V
V_{IL}	Logic 0 Input Voltage		-0.3		0.8	V
I_{IN}	Input Current	$0\text{V} < V_{\text{IN}} < 5.5\text{V}$			± 1	μA
VPP Output						
$I_{\text{PP OUT Hi-Z}}$	High-Impedance Output Leakage Current	Shutdown Mode $1\text{V} \leq V_{\text{PP OUT}} \leq 12\text{V}$		1	10	μA
$I_{\text{PP SC}}$	Short Circuit Current Limit	$V_{\text{PP OUT}} = 0$		0.2		A
R_{O}	Switch Resistance, $I_{\text{PP OUT}} = -100\text{mA}$ (sourcing)	select $V_{\text{PP OUT}} = 12\text{V}$		0.55	1	Ω
		select $V_{\text{PP OUT}} = 5\text{V}$		0.7	1	Ω
		select $V_{\text{PP OUT}} = 3.3\text{V}$		2	3	Ω
	Switch Resistance, $I_{\text{PP OUT}} = 50\mu\text{A}$	select $V_{\text{PP OUT}} = \text{clamped to ground}$		0.75	2	k Ω
VPP Switching Time						
t_1	Output Turn-On Rise Time	$V_{\text{PP OUT}} = \text{hi-Z to } 5\text{V}$		50		μs
t_2	Output Turn-On Rise Time	$V_{\text{PP OUT}} = \text{hi-Z to } 3.3\text{V}$		40		μs
t_3	Output Turn-On Rise Time	$V_{\text{PP OUT}} = \text{hi-Z to } 12\text{V}$		300		μs
t_4	Output Rise Time	$V_{\text{PP OUT}} = 3.3\text{V or } 5\text{V to } 12\text{V}$		300		μs
VCC Output						
$I_{\text{CC OUT Hi-Z}}$	High Impedance Output Leakage Current, Note 3	$1\text{V} \leq V_{\text{CC OUT}} \leq 5\text{V}$		1	10	μA
$I_{\text{CC SC}}$	Short Circuit Current Limit	$V_{\text{CC OUT}} = 0$	1	2		A
R_{O}	Switch Resistance, $V_{\text{CC OUT}} = 5.0\text{V}$	$I_{\text{CC OUT}} = -1000\text{mA}$ (sourcing)		70	100	m Ω
	Switch Resistance, $V_{\text{CC OUT}} = 3.3\text{V}$	$I_{\text{CC OUT}} = -1000\text{mA}$ (sourcing)		40	66	m Ω
VCC Switching Time						
t_1	Rise Time	$V_{\text{CC OUT}} = 0\text{V to } 3.3\text{V}$, $I_{\text{OUT}} = 1\text{A}$	100	600		μs
t_2	Rise Time	$V_{\text{CC OUT}} = 0\text{V to } 5.0\text{V}$, $I_{\text{OUT}} = 1\text{A}$	100	500		μs
t_3	Fall Time	$V_{\text{CC OUT}} = 5.0\text{V to } 3.3\text{V}$		300		μs
t_4	Rise Time	$V_{\text{CC OUT}} = \text{hi-Z to } 5\text{V}$		400		μs

Symbol	Parameter	Condition	Min	Typ	Max	Units
Power Supply						
I_{CC5}	$V_{CC5\ IN}$ Supply Current	$I_{CC\ OUT} = 0$		0.01	10	μA
I_{CC3}	$V_{CC3\ IN}$ Supply Current	$V_{CC\ OUT} = 5V$ or $3.3V$, $I_{CC\ OUT} = 0$		30	50	μA
		$V_{CC\ OUT} = hi-Z$ (Sleep mode)		0.01	10	μA
$I_{PP\ IN}$	$V_{PP\ IN}$ Supply Current ($I_{PP\ OUT} = 0$)	V_{CC} active, $V_{PP\ OUT} = 5V$ or $3.3V$		15	50	μA
		$V_{PP\ OUT} = hi-Z$, 0 or V_{PP}		0.01	10	μA
$V_{CC5\ IN}$	Operating Input Voltage	$V_{CC5\ IN} \geq V_{CC3\ IN}$	$V_{CC3\ IN}$	5.0	6	V
$V_{CC3\ IN}$	Operating Input Voltage	$V_{CC3\ IN} \leq V_{CC5\ IN}$	2.8	3.3	$V_{CC3\ IN}$	V
$V_{PP\ IN}$	Operating Input Voltage		8.0	12.0	14.5	V
Suspend Mode (Note 4)						
I_{CC3}	Active Mode Current	$V_{PP\ IN} = 0V$, $V_{CC3} = V_{CC3} = 3.3V$ $V_{CC3} = \text{enabled}$ $V_{PP} = \text{disabled (hi-Z or 0V)}$		30		μA
$R_{ON\ V_{CC}}$	$V_{CC\ OUT}$ R_{ON}	$V_{PP\ IN} = 0V$, $V_{CC5} = V_{CC3} = 3.3V$ $V_{CC3} = \text{enabled}$ $V_{PP} = \text{disabled (hi-Z or 0V)}$		4.5		Ω

Notes:

- Functional operation above the absolute maximum stress ratings is not implied.
- Static-sensitive device. Store only in conductive containers. Handling personnel and equipment should be grounded to prevent damage from static discharge.
- Leakage current after 1,000 hours at 125°C may increase up to five times the initial limit.
- Suspend mode is a pseudo-power-down mode the MIC2560 automatically allows when $V_{PP\ IN} = 0V$, $V_{PP\ OUT}$ is deselected, and $V_{CC\ OUT} = 3.3V$ is selected. Under these conditions, the MIC2560 functions in a reduced capacity mode where V_{CC} output of 3.3V is allowed, but at lower current levels (higher switch on-resistance).

Application Information

PCMCIA V_{CC} and V_{PP} control is easily accomplished using the MIC2560 voltage selector/switch IC. Four control bits determine $V_{CC\ OUT}$ and $V_{PP\ OUT}$ voltage and standby/operate mode condition. $V_{PP\ OUT}$ output voltages of V_{CC} (3.3V or 5V), V_{PP} , or a high impedance state are available. When the V_{CC} high impedance condition is selected, the device switches into “sleep” mode and draws only nano-amperes of leakage current. An error flag falls low if the output is improper, because of overtemperature or overcurrent faults. Full protection from hot switching is provided which prevents feedback from the $V_{PP\ OUT}$ to the V_{CC} inputs (from 12V to 5V, for example) by locking out the low voltage switch until $V_{PP\ OUT}$ drops below V_{CC} . The V_{CC} output is similarly protected against 5V to 3.3V shoot through.

The MIC2560 is a low-resistance power MOSFET switching matrix that operates from the computer system main power supply. Device logic power is obtained from V_{CC3} and internal MOSFET drive is obtained from the $V_{PP\ IN}$ pin (usually +12V) during normal operation. If +12V is not available, the MIC2560 automatically switches into “suspend” mode, where $V_{CC\ OUT}$ can be switched to 3.3V, but at higher switch resistance. Internal break-before-make switches determine the output voltage and device mode.

Supply Bypassing

External capacitors are not required for operation. The MIC2560 is a switch and has no stability problems. For best results however, bypass $V_{CC3\ IN}$, $V_{CC5\ IN}$, and $V_{PP\ IN}$ inputs with filter capacitors to improve output ripple. As all internal device logic and voltage/current comparison functions are powered from the $V_{CC3\ IN}$ line, supply bypass of this line is the most critical, and may be necessary in some cases. In the most stubborn layouts, up to 0.47 μ F may be necessary. Both $V_{CC\ OUT}$ and $V_{PP\ OUT}$ pins may have 0.01 μ F to 0.1 μ F capacitors for noise reduction and electrostatic discharge (ESD) damage prevention. Larger values of output capacitor might create current spikes during transitions, requiring larger bypass capacitors on the $V_{CC3\ IN}$, $V_{CC5\ IN}$, and $V_{PP\ IN}$ pins.

PCMCIA Implementation

The MIC2560 is designed for compatibility with the Personal Computer Memory Card International Association’s (PCMCIA) Specification, revision 2.1 as well as the PC Card Specification, (March 1995), including the CardBus option.

The Personal Computer Memory Card International Association (PCMCIA) specification requires two V_{PP} supply pins per PCMCIA slot. V_{PP} is primarily used for programming Flash (EEPROM) memory cards. The two V_{PP} supply pins may be programmed to different voltages. Fully implementing PCMCIA specifications requires a MIC2560, a MIC2557 PCMCIA V_{PP} Switching

Matrix, and a controller. Figure 3 shows this full configuration, supporting both 5.0V and 3.3V V_{CC} operation.

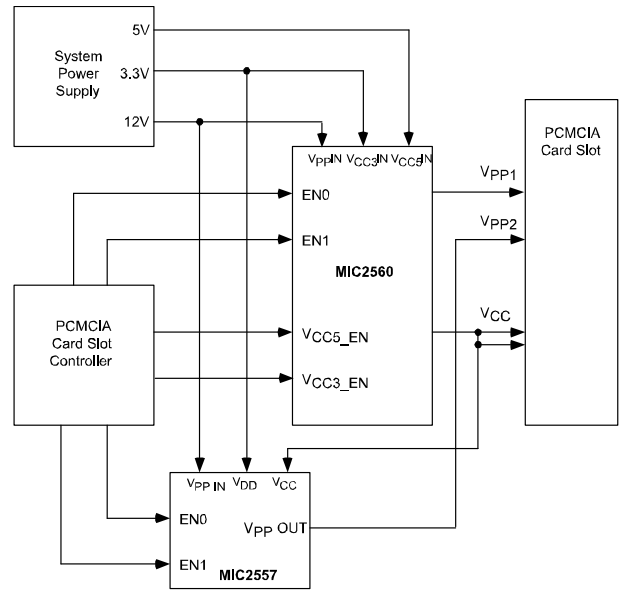

Figure 3. MIC2560 Typical PCMCIA Memory Card Application with Dual V_{CC} (5.0V or 3.3V) and separate V_{PP1} and V_{PP2} .

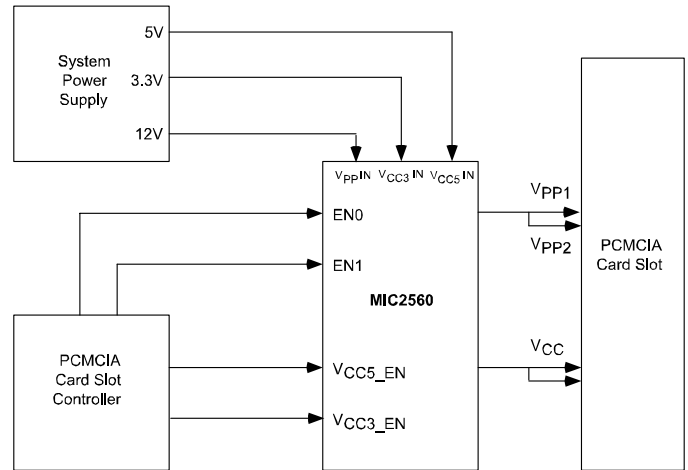

Figure 4. MIC2560 Typical PCMCIA Memory Card Application with Dual V_{CC} (5.0V or 3.3V). Note that V_{PP1} and V_{PP2} are Driven Together.

However, many cost sensitive designs (especially notebook/palmtop computers) connect V_{PP1} to V_{PP2} and the MIC2557 is not required. This circuit is shown in Figure 4.

When a memory card is initially inserted, it should receive V_{CC} — either 3.3V \pm 0.3V or 5.0V \pm 5%. The initial voltage is determined by a combination of mechanical socket “keys” and voltage sense pins. The card sends a handshaking data stream to the controller, which then determines whether or not this card requires V_{PP} and if the card is designed for dual V_{CC} . If the card is

compatible with and desires a different V_{CC} level, the controller commands this change by disabling V_{CC} , waiting at least 100ms, and then re-enabling the other V_{CC} voltage.

If no card is inserted or the system is in sleep mode, the controller outputs a $(V_{CC3\ IN}, V_{CC5\ IN}) = (0,0)$ to the MIC2560, which shuts down V_{CC} . This also places the switch into a high impedance output shutdown (sleep) mode, where current consumption drops to nearly zero, with only tiny CMOS leakage currents flowing.

During Flash memory programming with standard (+12V) Flash memories, the PCMCIA controller outputs a (1,0) to the EN0, EN1 control pins of the MIC2560, which connects $V_{PP\ IN}$ to $V_{PP\ OUT}$. The low ON resistance of the MIC2560 switches allow using small bypass capacitors (in some cases, none at all) on the $V_{CC\ OUT}$ and $V_{PP\ OUT}$ pins, with the main filtering action performed by a large filter capacitor on the input supply voltage to $V_{PP\ IN}$ (usually the main power supply filter capacitor is sufficient). The $V_{PP\ OUT}$ transition from V_{CC} to 12.0V typically takes 250 μ s. After programming is completed, the controller outputs a $(EN1, EN0) = (0,1)$ to the MIC2560, which then reduces $V_{PP\ OUT}$ to the V_{CC} level for read verification. Break-before-make switching action reduces switching transients and lowers maximum current spikes through the switch from the output capacitor. The flag comparator prevents having high voltage on the $V_{PP\ OUT}$ capacitor from contaminating the V_{CC} inputs, by disabling the low voltage V_{PP} switches until $V_{PP\ OUT}$ drops below the V_{CC} level selected. The lockout delay time varies with the load current and the capacitor on $V_{PP\ OUT}$. With a 0.1 μ F capacitor and nominal $I_{PP\ OUT}$, the delay is approximately 250 μ s.

Internal drive and bias voltage is derived from $V_{PP\ IN}$. Internal device control logic is powered from $V_{CC3\ IN}$. Input logic threshold voltages are compatible with common PCMCIA controllers using either 3.3V or 5V supplies. No pull-up resistors are required at the control inputs of the MIC2560.

Output Current and Protection

MIC2560 output switches are capable of more current than needed in PC Card applications (1A) and meet or exceed all PCMCIA specifications. For system and card protection, output currents are internally limited. For full system protection, long term (millisecond or longer) output short circuits invoke overtemperature shutdown, protecting the MIC2560, the system power supplies, the card socket pins, and the memory card. Overtemperature shutdown typically occurs at a die temperature of 115°C.

Single V_{CC} Operation

For PC Card slots requiring only a single V_{CC} , connect $V_{CC3\ IN}$ and $V_{CC5\ IN}$ together and to the system V_{CC} supply (i.e., Pins 1, 3, and 15 are all connected to system V_{CC}).

Either the V_{CC5} switch or the V_{CC3} switch may be used to enable the card slot V_{CC} ; generally the V_{CC3} switch is preferred because of its lower ON resistance.

Suspend Mode

An additional feature in the MIC2560 is a pseudo power-down mode, Suspend Mode, which allows operation without a $V_{PP\ IN}$ supply. In Suspend Mode, the MIC2560 supplies 3.3V to $V_{CC\ OUT}$ whenever a V_{CC} output of 3.3V is enabled by the PCMCIA controller. This mode allows the system designer the ability to turn OFF the V_{PP} supply generator to save power when it is not specifically required. The PCMCIA card receives V_{CC} at reduced capacity during Suspend Mode, as the switch resistance rises to approximately 4.5 Ω .

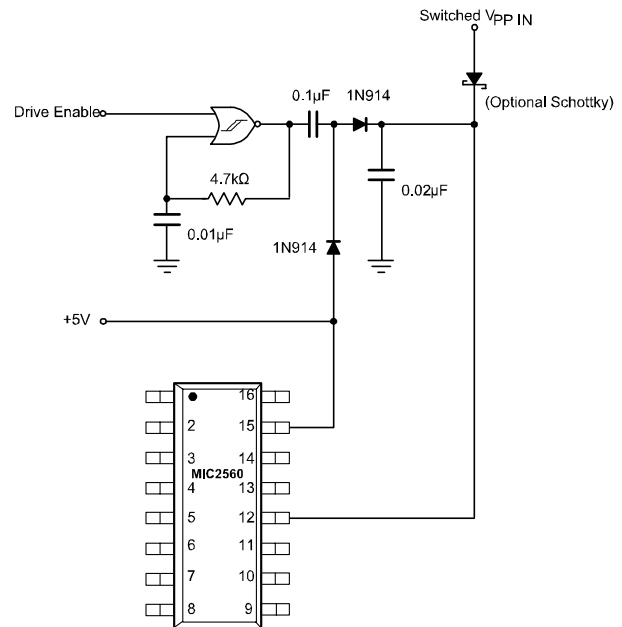

Figure 5. Circuit for Generating Bias Drive for the V_{CC} Switches when +12V is Not Readily Available.

High Current V_{CC} Operation Without a +12V Supply

Figure 5 shows the MIC2560 with V_{CC} switch bias provided by a simple charge pump. This enables the system designer to achieve full V_{CC} performance without a +12V supply, which is often helpful in battery powered systems that only provide +12V when it is needed. These on-demand +12V supplies generally have a quiescent current draw of a few milli-amperes, which is far more than the microamperes used by the MIC2560. The charge pump of figure 5 provides this low current, using about 100 μ A when enabled. When $V_{PP\ OUT} = 12V$ is selected, however, the on-demand V_{PP} generator must be used, as this charge pump cannot deliver the current required for Flash memory programming. The Schottky diode may not be necessary, depending on the configuration of the on-demand +12V generator and whether any other loads are on this line.