



## RVT4.3B480272CFWC81

### LCD TFT Datasheet

Rev.1.7

2016-08-23

ITEM	CONTENTS	UNIT
LCD Type	TFT/Transmissive/Normally white	/
Size	4.3	Inch
Viewing Direction	12:00 (without image inversion)	O' Clock
Gray Scale Inversion Direction	6:00	O' Clock
LCM (W × H × D )	106.30 × 68.00 × 8.95	mm <sup>3</sup>
Active Area (W × H)	95.04 × 53.86	mm <sup>2</sup>
Dot Pitch (W × H)	0.066×0.198	mm <sup>2</sup>
Number Of Dots	480 x (RGB) × 272	/
Driver IC	FT801	/
Backlight Type	10 LEDs	/
Surface Luminance	500	cd/m <sup>2</sup>
Interface Type	SPI/I2C	/
Color Depth	262k	/
Pixel Arrangement	RGB Vertical Stripe	/
Surface Treatment	Clear	
Input Voltage	3.3	V
With/Without TSP	Projected Capacitive Touch Panel	/
Weight	91	g

**Note 1:** RoHS compliant

**Note 2:** LCM weight tolerance: ± 5%.

## REVISION RECORD

REVNO.	REVDATE	CONTENTS	REMARKS
1.0	2014-11-12	Initial Release	
1.1	2015-01-19	Update LED lifetime	
1.2	2015-02-23	Update mode select information and thickness	
1.3	2015-05-27	Update Electrical Characteristics	
1.4	2015-06-12	Update Surface Treatment information	
1.5	2016-02-02	Update TP dimensions and total thickness	
1.6	2016-08-08	Added inspection standard	
1.7	2016-08-23	Update mechanical drawing	

## CONTENTS

REVISION RECORD.....	2
CONTENTS .....	3
1 MODULE CLASSIFICATION INFORMATION .....	4
2 MODULE DRAWING .....	4
3 ABSOLUTE MAXIMUM RATINGS.....	5
4 ELECTRICAL CHARACTERISTICS.....	5
5 ELECTRO-OPTICAL CHARACTERISTICS .....	5
6 INTERFACE DESCRIPTION .....	7
7 FT801 CONTROLLER SPECIFICATIONS .....	8
7.1 Serial host interface.....	8
7.2 Block Diagram.....	9
7.3 Host interface SPI mode 0 .....	9
7.4 Backlight driver block diagram .....	9
8 LCD TIMING CHARACTERISTICS .....	10
8.1 Clock and data input time diagram .....	10
8.2 Parallel RGB input timing table .....	10
9 CAPACITIVE TOUCH SCREEN PANEL SPECIFICATIONS .....	11
9.1 Mechanical characteristics .....	11
9.2 Electrical characteristics .....	11
10 INSPECTION .....	12
10.1 Inspection condition.....	12
Ambient conditions: .....	12
Viewing distance: .....	12
Viewing Angle: .....	12
10.2 Inspection standard.....	13
11 RELIABILITY TEST .....	16
12 LEGAL INFORMATION.....	17

## 1 MODULE CLASSIFICATION INFORMATION

RV	T	4.3	B	480272	C	F	W	C	81
1.	2.	3.	4.	5.	6.	7.	8.	9.	10.

1.	<b>BRAND</b>	<b>RV</b> – Riverdi
2.	<b>PRODUCT TYPE</b>	<b>T – TFT Standard</b> F – TFT Custom
3.	<b>DISPLAY SIZE</b>	3.5 – 3.5” <b>4.3 – 4.3”</b> 5.0 – 5.0” 7.0 – 7.0”
4.	<b>MODEL SERIAL NO.</b>	<b>B (A-Z)</b>
5.	<b>RESOLUTION</b>	320240 – 320x240 px <b>480272 – 480x272 px</b> 800480 – 800x480 px
6.	<b>INTERFACE</b>	<b>T – TFT LCD, RGB</b> L – TFT LCD, LVDS <b>C – TFT + Controller</b>
7.	<b>FRAME</b>	N – No Frame <b>F – Mounting Frame</b>
8.	<b>BACKLIGHT TYPE</b>	<b>W – LED White</b>
9.	<b>TOUCH PANEL</b>	N – No Touch Panel R – Resistive Touch Panel <b>C – Capacitive Touch Panel</b>
10.	<b>VERSION</b>	<b>81</b> (00-99)

PIN	DESC
1	VDD
2	GND
3	SPI_SCLK / I2C_SCL
4	MISO / I2C_SDA
5	MOSI / I2C_SA0
6	CS / I2C_SA1
7	INT
8	PD
9	MODE
10	AUDIO_OUT
11	NC
12	NC
13	NC
14	NC
15	NC
16	NC
17	BLVDD
18	BLVDD
19	BLGND
20	BLGND

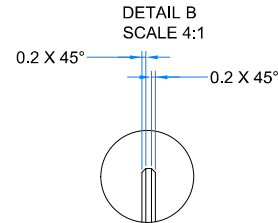
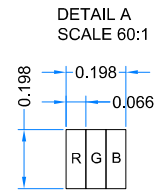
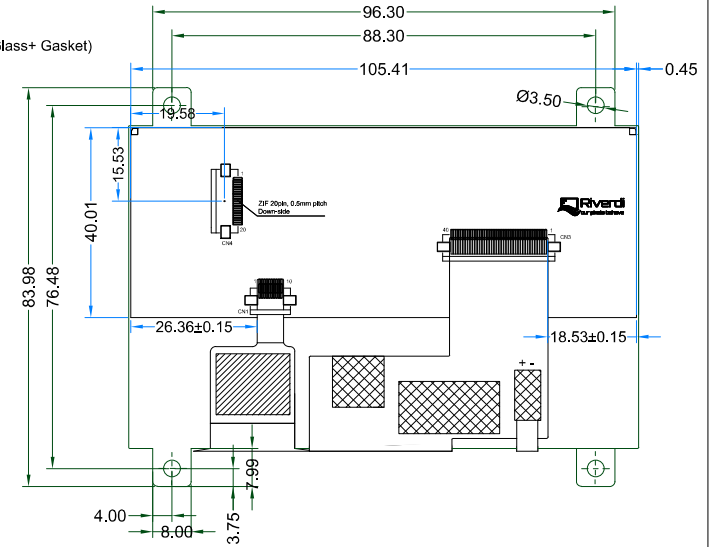
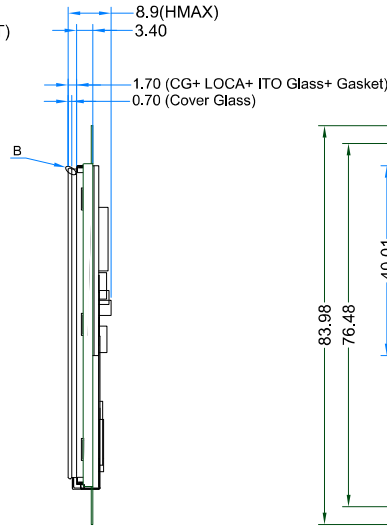
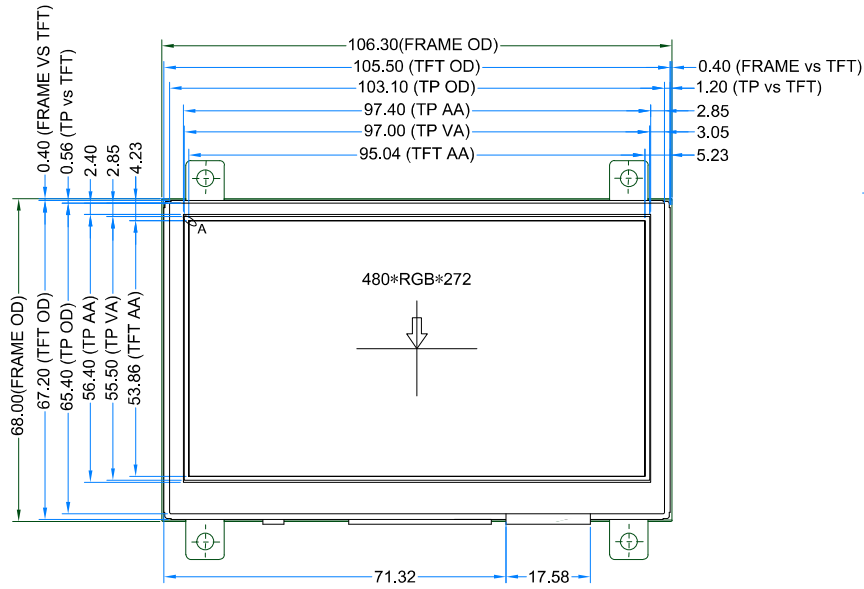

INTERNAL BACKLIGHT LED CONNECTION

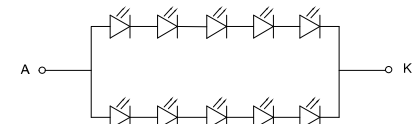

NOTES:

1. DISPLAY TYPE: TFT, TRANSMISSIVE, NORMALLY WHITE
2. OPERATION VOLTAGE: VDD=3.3V
3. VIEWING DIRECTION: 12 O'CLOCK
4. IC CONTROLLER: FT801
5. OPERATING TEMP.: -20°C ~ 70°C
6. STORAGE TEMP.: -30°C ~ 80°C
7. LED BACKLIGHT: 10-LED WHITE, BUILT-IN INVERTER
8. SURFACE LUMINANCE: 500 cd/m<sup>2</sup>
9. GENERAL TOLERANCE: ±0.2
10. RoHS COMPLIANT

1.4	Update thickness	2016.08.23
1.3	Update TP dimensions and total thickness	2016.02.02
1.2	Update thickness	2015.02.23
1.1	Update LED lifetime	2015.01.19
1.0	Initial case	2014.11.12
Ver.	DESCRIPTION	DATE

CUSTOMER APVL		DATE	2016/02/02
DRAWN		SCALE	TITLE
DFTG CHK		UNIT	RVT4.3B48027CFWC81
ENGR CHK		mm	MODEL
APPROVAL			DWG NO
		Rev.1.3	PAGE
			1/1

### 3 ABSOLUTE MAXIMUM RATINGS

PARAMETER	SYMBOL	MIN	MAX	UNIT
Supply Voltage For Logic	VDD	-0.3	3.6	V
Input Voltage For Logic	VIN	-0.3	VDD	V
Input Voltage For LED Inverter	BLVDD	-0.3	7.0	V
Operating Temperature	T <sub>OP</sub>	-20	70	°C
Storage Temperature	T <sub>ST</sub>	-30	80	°C
Humidity	RH	-	90% (Max 60°C)	RH

### 4 ELECTRICAL CHARACTERISTICS

PARAMETER	SYMBOL	MIN	TYP	MAX	UNIT	NOTES
Supply Voltage For Module	VDD	3.0	3.3	3.6	V	
Input Voltage for LED Inverter	BLVDD	2.8	3.3	5.5	V	
Input Current (Exclude LED Backlight)	IDD	-	70	87	mA	VDD = 3.3V
LED Backlight Current	IDD <sub>backlight</sub>	-	260	325	mA	BLVDD=3.3V
LED Backlight Current	IDD <sub>backlight</sub>	-	150	187	mA	BLVDD=5V
Total Input Current (Include LED Backlight 100%)	IDD <sub>total</sub>	-	330	412	mA	BLVDD=3.3V
Input Voltage ' H ' level	V <sub>IH</sub>	0.7VDD	-	VDD	V	
Input Voltage ' L ' level	V <sub>IL</sub>	0	-	0.2VDD	V	
LED Life Time	-	30000	50000	-	Hrs	Note 1

**Note 1:** The LED life time is defined as the module brightness decrease to 50% original brightness at Ta=25°C.

### 5 ELECTRO-OPTICAL CHARACTERISTICS

ITEM	SYMBOL	CONDITION	MIN	TYP	MAX	UNIT	REMARK	NOTE
Response Time	Tr+Tf		-	25	30	ms	Figure 1	4
Contrast Ratio	Cr		400	500	-	---	Figure 2	1
Luminance Uniformity	δ WHITE	θ=0° φ=0° Ta=25	80	-	-	%	Figure 2	3
Surface Luminance	Lv		-	500	-	cd/m <sup>2</sup>	Figure 2	2
Viewing Angle Range	θ	φ = 90°	40	50	-	deg	Figure 3	6
		φ = 270°	60	70	-	deg	Figure 3	
		φ = 0°	60	70	-	deg	Figure 3	
		φ = 180°	60	70	-	deg	Figure 3	
CIE (x, y) Chromaticity	Red	θ=0° φ=0° Ta=25	0.551	0.591	0.631	Figure 2	5	
			0.270	0.310	0.350			
	Green		0.302	0.342	0.382			
			0.516	0.561	0.601			
	Blue		0.105	0.145	0.185			
			0.047	0.087	0.127			
	White		0.250	0.290	0.330			
			0.300	0.340	0.380			

**Note 1.** Contrast Ratio(CR) is defined mathematically as below, for more information see Figure 1.

$$\text{Contrast Ratio} = \frac{\text{Average Surface Luminance with all white pixels (P1, P2, P3, P4, P5)}}{\text{Average Surface Luminance with all black pixels (P1, P2, P3, P4, P5)}}$$

**Note 2.** Surface luminance is the LCD surface from the surface with all pixels displaying white. For more information see

Figure 2.

$L_v$  = Average Surface Luminance with all white pixels (P1, P2, P3, P4, P5)

**Note 3.** The uniformity in surface luminance  $\delta$  WHITE is determined by measuring luminance at each test position 1 through 5, and then dividing the maximum luminance of 5 points luminance by minimum luminance of 5 points luminance. For more information see

Figure 2.

$$\delta \text{ WHITE} = \frac{\text{Minimum Surface Luminance with all white pixels (P1, P2, P3, P4, P5)}}{\text{Maximum Surface Luminance with all white pixels (P1, P2, P3, P4, P5)}}$$

**Note 4.** Response time is the time required for the display to transition from white to black (Rise Time,  $T_r$ ) and from black to white (Decay Time,  $T_f$ ). For additional information see FIG 1. The test equipment is Autronic-Melchers’s ConoScope series.

**Note 5.** CIE (x, y) chromaticity, the x, y value is determined by measuring luminance at each test position 1 through 5, and then make average value.

**Note 6.** Viewing angle is the angle at which the contrast ratio is greater than 2. For TFT module the contrast ratio is greater than 10. The angles are determined for the horizontal or x axis and the vertical or y axis with respect to the z axis which is normal to the LCD surface. For more information see Figure 3.

**Note 7.** For viewing angle and response time testing, the testing data is based on Autronic-Melchers’s ConoScope series. Instruments for Contrast Ratio, Surface Luminance, Luminance Uniformity, CIE the test data is based on TOPCON’s BM-5 photo detector.

Figure 1. The definition of response time

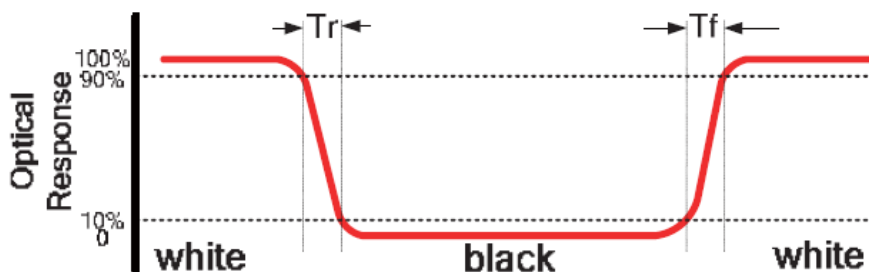

Figure 2. Measuring method for Contrast ratio, surface luminance, Luminance uniformity, CIE (x, y) chromaticity

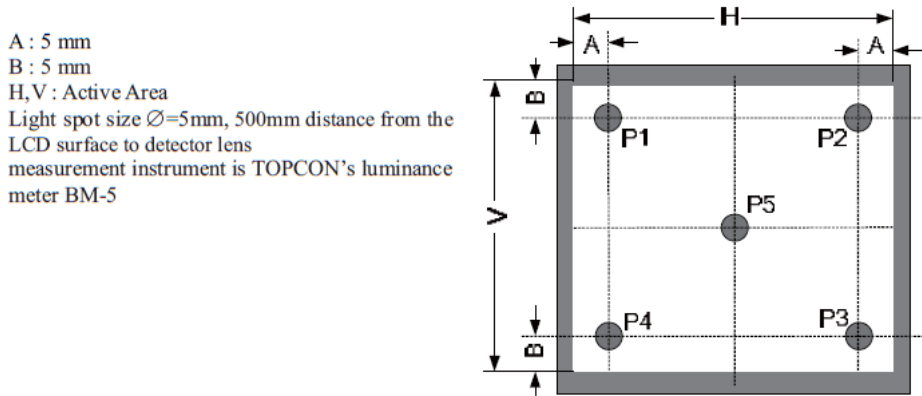
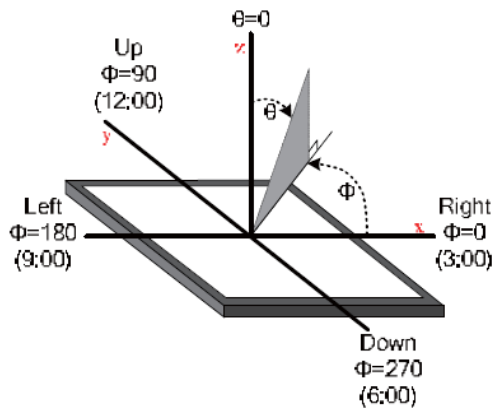

Figure 3. The definition of viewing angle



## 6 INTERFACE DESCRIPTION

PIN NO.	SYMBOL	DESCRIPTION
1	VDD	Power Supply
2	GND	Ground
3	SPI_SCLK/ I2C_SCL	SPI SCK Signal / I2C SCL Signal, Internally 47k Pull UP
4	MISO/ I2C_SDA	SPI MISO Signal / I2C SDA Signal, Internally 47k Pull UP
5	MOSI/ I2C_SA0	SPI MOSI Signal / I2C Slave Address Bit 0, Internally 47k Pull UP
6	CS/I2C_SA1	SPI Chip Select Signal / I2C Slave Address Bit 1, Internally 47k Pull UP
7	INT	Interrupt Signal, Active Low, Internally 47k Pull UP
8	PD	Power Down Signal, Active Low, Internally 47k Pull UP
9	MODE	Host Interface SPI(Pull Low) or I2C(Pull Up) Mode Select Input, Internally 10k Pull DOWN
10	AUDIO_OUT	Audio Out Signal
11	NC	Not Connected
12	NC	Not Connected
13	NC	Not Connected
14	NC	Not Connected
15	NC	Not Connected
16	NC	Not Connected
17	BLVDD	Backlight Power Supply, Can Be Connected to VDD
18	BLVDD	Backlight Power Supply, Can Be Connected to VDD
19	BLGND	Backlight Ground, Internally connected to GND
20	BLGND	Backlight Ground, Internally connected to GND



## 7 FT801 CONTROLLER SPECIFICATIONS

FT801 or EVE (Embedded Video Engine) simplifies the system architecture for advanced human machine interfaces (HMIs) by providing functionality for display, audio, and touch as well as an object oriented architecture approach that extends from display creation to the rendering of the graphics.

### 7.1 Serial host interface

Figure 4.SPI interface connection

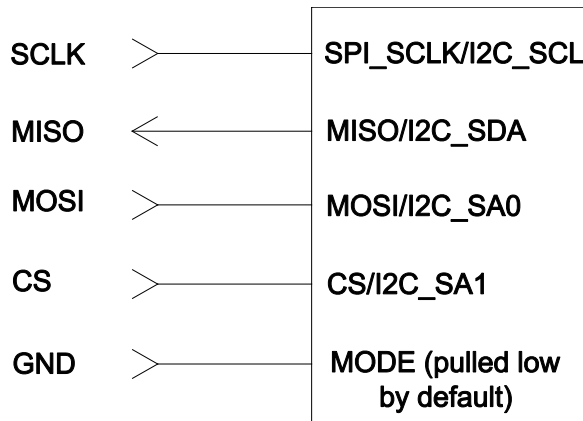
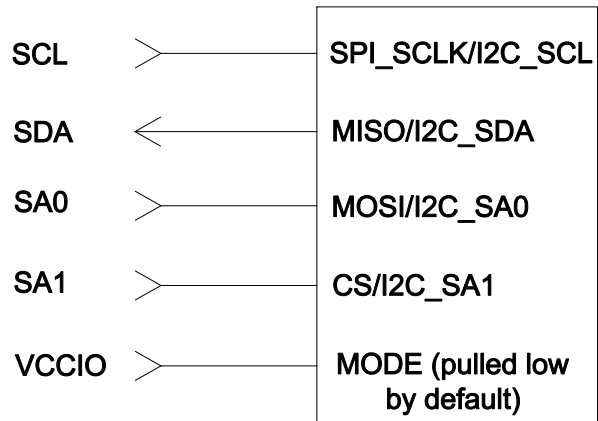

Figure 5.I2C interface connection



**SPI Interface** – the SPI slave interface operates up to 30MHz.

Only SPI mode 0 is supported. The SPI interface is selected by default (MODE pin is internally pulled low by 47k resistor).

**I<sup>2</sup>C Interface** – the I<sup>2</sup>C slave interface operates up to 3.4MHz, supporting standard-mode, fast-mode, fast-mode plus and high-speed mode.

The I<sup>2</sup>C device address is configurable between 20h to 23h depending on the I<sup>2</sup>C\_SA[1:0] pin setting, i.e. the 7-bit I<sup>2</sup>C slave address is 0b'01000A1A0.

The I<sup>2</sup>C interface is selected when the MODE pin is tied to VDDIO.

### 7.2 Block Diagram

Figure 6. FT801 Block diagram

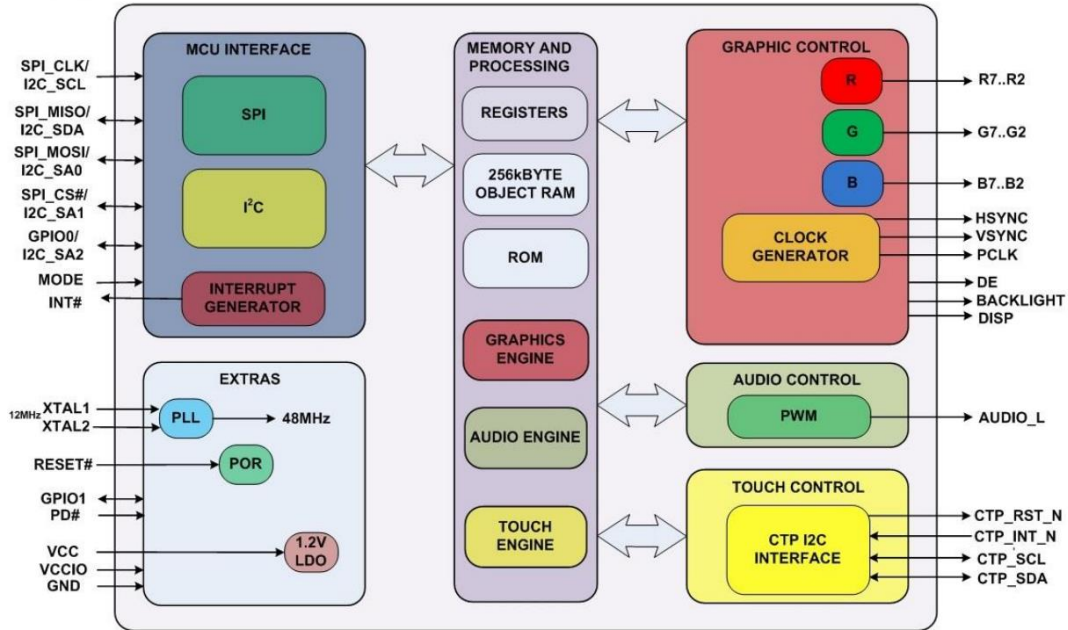

### 7.3 Host interface SPI mode 0

Figure 7. SPI timing diagram

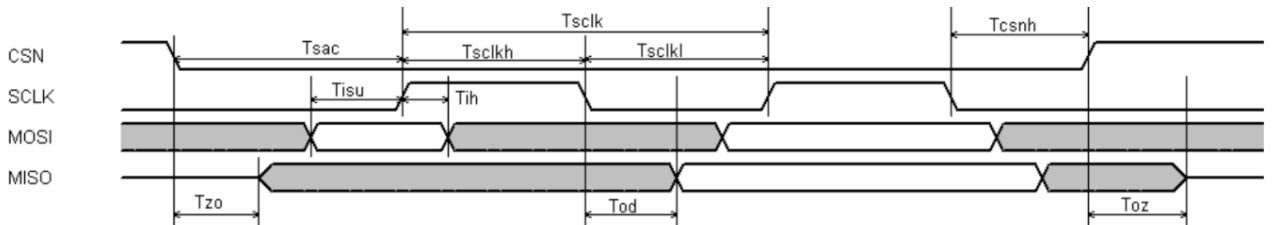

For more information about FT801 controller please go to official FT801 Datasheet.  
[http://www.ftdichip.com/Support/Documents/DataSheets/ICs/DS\\_FT801.pdf](http://www.ftdichip.com/Support/Documents/DataSheets/ICs/DS_FT801.pdf)

### 7.4 Backlight driver block diagram

Backlight enable signal is internally connected to FT801 Backlight control pin. This pin is controlled by two FT801's registers. One of them specifies the PWM output frequency, second one specifies the duty cycle. Refer to FT801 datasheet for more information.

Figure 8. Backlight driver block diagram

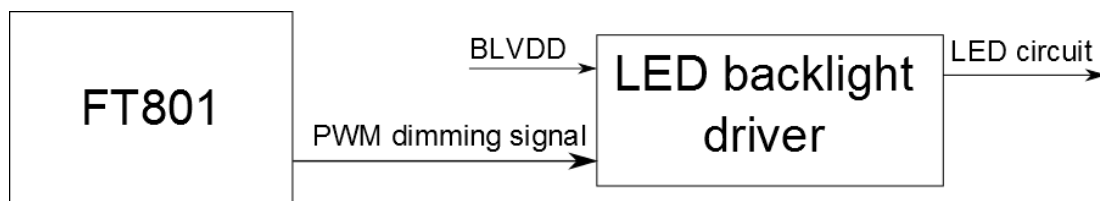

## 8 LCD TIMING CHARACTERISTICS

### 8.1 Clock and data input time diagram

Figure 9. Clock and data input time diagram

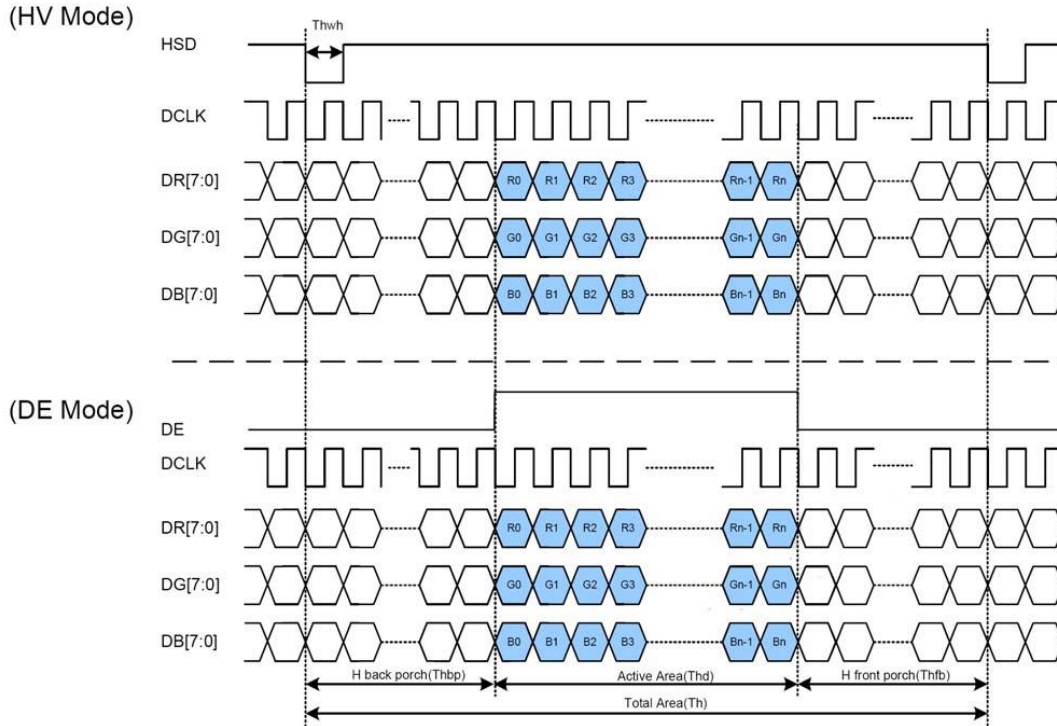

### 8.2 Parallel RGB input timing table

PARAMETER	SYMBOL	MIN	TYP	MAX	UNIT
DCLK Frequency	Fclk	5	9	12	MHz
VSD Period Time	Tv	277	288	400	H
VSD Display Area	Tvd		272		H
VSD Back Porch	Tvb	3	8	31	H
VSD Front Porch	Tvfp	2	8	97	H
HSD Period Time	Th	520	525	800	DCLK
HSD Display Area	Thd		480		DCLK
HSD Back Porch	Thbp	36	40	255	DCLK
HSD Front Porch	Thfp	4	5	65	DCLK

## 9 CAPACITIVE TOUCH SCREEN PANEL SPECIFICATIONS

Capacitive Touch Panel is directly connected to FT801 module. Therefore communication with Capacitive touch panel is simplified to read registers of FT801.

Figure 10. Capacitive Touch Panel Connection

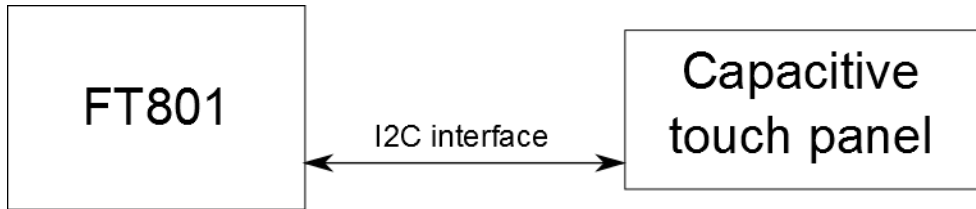

### 9.1 Mechanical characteristics

DESCRIPTION	INL SPECIFICATION	REMARK
<b>Touch Panel Size</b>	4.3 inch	
<b>Outline Dimension (OD)</b>	103.1mm x 65.4mm	Cover Lens Outline
<b>Product Thickness</b>	1.7mm	
<b>Glass Thickness</b>	0.7mm	
<b>Ink View Area</b>	97.0mm x 55.5mm	
<b>Sensor Active Area</b>	97.4mm x 56.4mm	
<b>Input Method</b>	5 Finger	
<b>Activation Force</b>	Touch	
<b>Surface Hardness</b>	≥7H	

### 9.2 Electrical characteristics

DESCRIPTION	SPECIFICATION
Operating Voltage	DC 2.8~3.3V
Power Consumption (IDD)	Active Mode
	Sleep Mode
Interface	I <sup>2</sup> C
Linearity	<1.5%
Controller	FT5306
I2C address	0x38 (7 bit address)
Resolution	1280*768

## 10 INSPECTION

Standard acceptance/rejection criteria for TFT module.

### 10.1 Inspection condition

Ambient conditions:

- Temperature:  $25\pm^{\circ}\text{C}$
- Humidity:  $(60\pm 10)\%RH$
- Illumination: Single fluorescent lamp non-directive (300 to 700 lux)

Viewing distance:

$35\pm 5\text{cm}$  between inspector bare eye and LCD.

Viewing Angle:

U/D:  $45^{\circ}/45^{\circ}$ , L/R  $45^{\circ}/45^{\circ}$

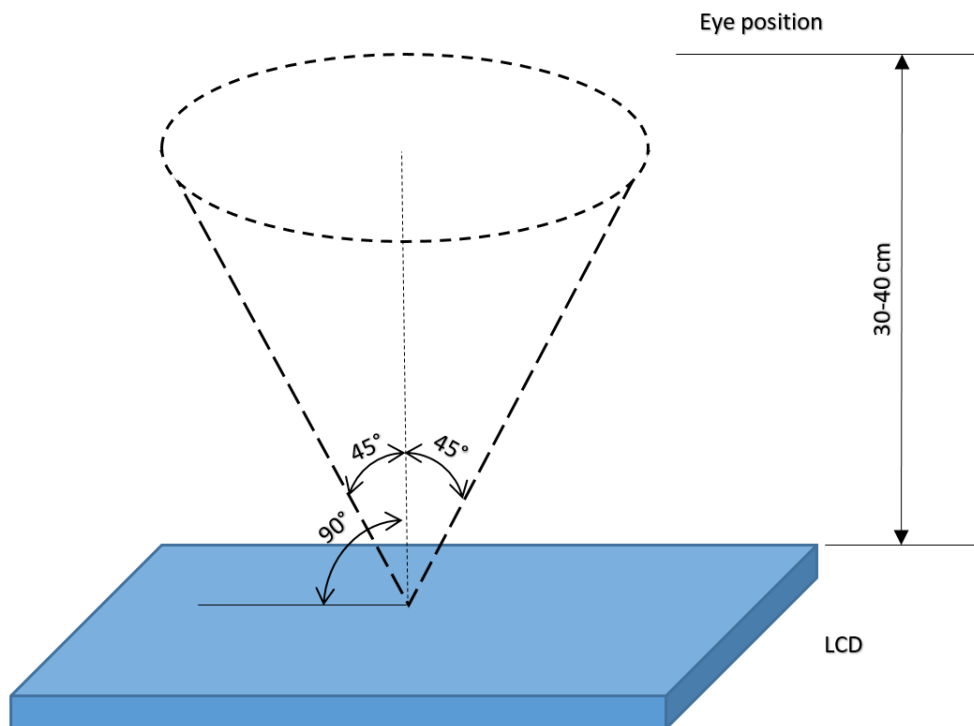

10.2 Inspection standard

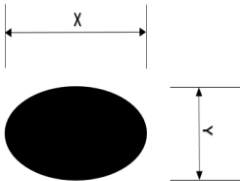
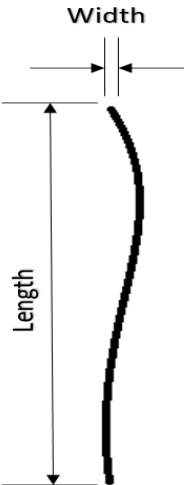
Item	Criterion																																		
<p><b>Black spots, white spots, light leakage, Foreign Particle (round Type)</b></p>	<div style="display: flex; align-items: center; justify-content: center;">  <table border="1" style="margin-left: 20px;"> <thead> <tr> <th colspan="2">Size &lt; 5"</th> </tr> <tr> <th>Average Diameter</th> <th>Qualified Qty</th> </tr> </thead> <tbody> <tr> <td>D &lt; 0.2 mm</td> <td>Ignored</td> </tr> <tr> <td>0.2 mm &lt; D &lt; 0.3 mm</td> <td>3</td> </tr> <tr> <td>0.3 mm &lt; D &lt; 0.5 mm</td> <td>2</td> </tr> <tr> <td>0.5 mm &lt; D</td> <td>0</td> </tr> </tbody> </table> </div> <div style="text-align: center; margin: 10px 0;"> <math display="block">D = \frac{(x + y)}{2}</math> </div> <p>*Spots density: 10 mm</p>	Size < 5"		Average Diameter	Qualified Qty	D < 0.2 mm	Ignored	0.2 mm < D < 0.3 mm	3	0.3 mm < D < 0.5 mm	2	0.5 mm < D	0																						
Size < 5"																																			
Average Diameter	Qualified Qty																																		
D < 0.2 mm	Ignored																																		
0.2 mm < D < 0.3 mm	3																																		
0.3 mm < D < 0.5 mm	2																																		
0.5 mm < D	0																																		
<p><b>LCD black spots, white spots, light leakage (line Type)</b></p>	<div style="display: flex; align-items: center; justify-content: center;">  <table border="1" style="margin-left: 20px;"> <thead> <tr> <th colspan="3">Size &lt; 5"</th> </tr> <tr> <th>Length</th> <th>Width</th> <th>Qualified Qty</th> </tr> </thead> <tbody> <tr> <td>-</td> <td>W &lt; 0.02</td> <td>Ignored</td> </tr> <tr> <td>L &lt; 3.0</td> <td>0.02 &lt; W &lt; 0.05</td> <td rowspan="2">2</td> </tr> <tr> <td>L &lt; 2.5</td> <td>0.05 &lt; W &lt; 0.08</td> </tr> <tr> <td>-</td> <td>0.08 &lt; W</td> <td>0</td> </tr> </tbody> </table> </div> <div style="margin: 10px 0;"> <table border="1" style="width: 100%;"> <thead> <tr> <th colspan="3">Size &gt;= 5"</th> </tr> <tr> <th>Length</th> <th>Width</th> <th>Qualified Qty</th> </tr> </thead> <tbody> <tr> <td>-</td> <td>W &lt; 0.02</td> <td>Ignored</td> </tr> <tr> <td>L &lt; 3.0</td> <td>0.02 &lt; W &lt; 0.05</td> <td rowspan="2">4</td> </tr> <tr> <td>L &lt; 2.5</td> <td>0.05 &lt; W &lt; 0.08</td> </tr> <tr> <td>-</td> <td>0.08 &lt; W</td> <td>0</td> </tr> </tbody> </table> </div> <p>*Spots density: 10 mm</p>	Size < 5"			Length	Width	Qualified Qty	-	W < 0.02	Ignored	L < 3.0	0.02 < W < 0.05	2	L < 2.5	0.05 < W < 0.08	-	0.08 < W	0	Size >= 5"			Length	Width	Qualified Qty	-	W < 0.02	Ignored	L < 3.0	0.02 < W < 0.05	4	L < 2.5	0.05 < W < 0.08	-	0.08 < W	0
Size < 5"																																			
Length	Width	Qualified Qty																																	
-	W < 0.02	Ignored																																	
L < 3.0	0.02 < W < 0.05	2																																	
L < 2.5	0.05 < W < 0.08																																		
-	0.08 < W	0																																	
Size >= 5"																																			
Length	Width	Qualified Qty																																	
-	W < 0.02	Ignored																																	
L < 3.0	0.02 < W < 0.05	4																																	
L < 2.5	0.05 < W < 0.08																																		
-	0.08 < W	0																																	

Item	Criterion	
Clear spots	Size < 5"	
	<b>Average Diameter</b>	Qualified Qty
	<b>D &lt; 0.2 mm</b>	Ignored
	<b>0.2 mm &lt; D &lt; 0.3 mm</b>	3
	<b>0.3 mm &lt; D &lt; 0.5 mm</b>	2
	<b>0.5 mm &lt; D</b>	0
	Size >= 5"	
	<b>Average Diameter</b>	Qualified Qty
	<b>D&lt;0.2 mm</b>	Ignored
	<b>0.2 mm &lt; D &lt; 0.3 mm</b>	4
	<b>0.3 mm &lt; D &lt; 0.5 mm</b>	2
	<b>0.5 mm &lt; D</b>	0
	*Spots density: 10 mm	
	Polarizer bubbles	Size < 5"
<b>Average Diameter</b>		Qualified Qty
<b>D &lt; 0.2 mm</b>		Ignored
<b>0.2 mm &lt; D &lt; 0.5 mm</b>		3
<b>0.5 mm &lt; D &lt; 1 mm</b>		2
<b>1 mm &lt; D</b>		0
<b>Total Q'ty</b>		3
Size >= 5"		
<b>Average Diameter</b>		Qualified Qty
<b>D&lt;0.25 mm</b>		Ignored
<b>0.25 mm &lt; D &lt; 0.5 mm</b>		3
<b>0.5 mm &lt; D</b>		0
Electrical Dot Defect		Size < 5"
		<b>item</b>
	<b>Black do defect</b>	4
	<b>Bright dot defect</b>	2
	<b>Total Dot</b>	5
	Size >= 5"	
	<b>item</b>	Qualified Qty
	<b>Black do defect</b>	5
	<b>Bright dot defect</b>	2
	<b>Total Dot</b>	5

Item	Criterion		
Touch panel spot	Size < 5"		
	<b>Average Diameter</b>	Qualified Qty	
	<b>D &lt; 0.2 mm</b>	Ignored	
	<b>0.2 mm &lt; D &lt; 0.4 mm</b>	5	
	<b>0.4 mm &lt; D &lt; 0.5 mm</b>	2	
	<b>0.5 mm &lt; D</b>	0	
	Size >= 5"		
	<b>Average Diameter</b>	Qualified Qty	
	<b>D &lt; 0.25 mm</b>	Ignored	
	<b>0.25 mm &lt; D &lt; 0.5 mm</b>	4	
	<b>0.5 mm &lt; D</b>	0	
	Touch panel White line Scratch	Size < 5"	
<b>Length</b>		<b>Width</b>	Qualified Qty
-		W < 0.02	Ignored
<b>L &lt; 3.0</b>		0.02 < W < 0.05	2
<b>L &lt; 2.5</b>		0.05 < W < 0.08	
-		0.08 < W	0
Size >= 5"			
<b>Length</b>		<b>Width</b>	Qualified Qty
-		W < 0.03	Ignored
<b>L &lt; 5.0</b>		0.03 < W < 0.05	2
-		0.05 < W	0



## 11 RELIABILITY TEST

NO.	TEST ITEM	TEST CONDITION
1	High Temperature Storage	80±2°C/240hours
2	Low Temperature Storage	-30±2°C/240hours
3	High Temperature Operating	70±2°C/240hours
4	Low Temperature Operating	-20±2°C/240hours
5	Temperature Cycle	-30±2°C~25~80±2°C × 20 cycles (30min.) (5min.) (30min.)
6	Damp Proof Test	60°C ±5°C × 90%RH/240hours
7	Vibration Test	Frequency 10Hz~55Hz Amplitude of vibration : 1.5mm Sweep: 10Hz~55Hz~10Hz X, Y, Z 2 hours for each direction.
8	Package Drop Test	Height:60 cm 1 corner,3 edges,6 surfaces
9	ESD Test	Air: ±4KV 150pF/330Ω 5 times Contact: ±2KV 150pF/330Ω 5 time