

HEXIWEAR WorkStation

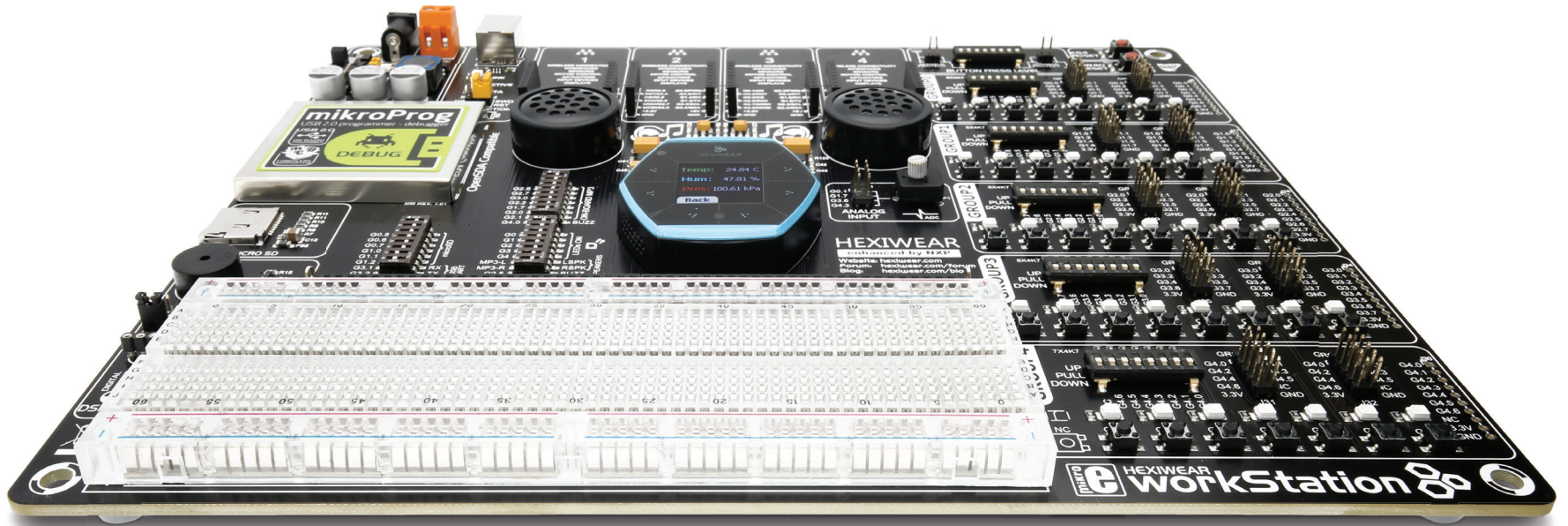

Part of the
Hexiwear development
ecosystem



Multimedia
peripherals
onboard



Amazing connectivity
– 3 connectors at
each I/O group



Click board™
connectivity with four
mikroBUS™ sockets



OpenSDA compatible
programmer and
In-Circuit Debugger

To our valued customers

Hexiwear is one of the smallest development platforms available, rich with features. It is small enough to be categorized as a wearable device. It features an eye-catching smartwatch form factor, packing a powerful, low power Kinetis® K64F MCU and 6 onboard sensors, along with the K40Z SoC, which offers a Bluetooth Low Energy radio that can be used to connect to the Cloud services. This makes **Hexiwear** an ideal solution for building portable IoT applications. It was selected as **the best rapid prototyping platform of the year 2016** by the **ECN IMPACT awards** website, as well as the well-known **hackster.io community**. It was also awarded at the **ARM TechCon 2016 event**, in three categories: Best IOT platform, Best in Show, Readers choice.

Considering the success of Hexiwear, we came to a conclusion that such a great platform deserves a full-fledged development workstation board. This would allow even faster prototyping, by using a greater number of additional features. We at MikroElektronika, are proud to present a Hexiwear Workstation board - a docking platform for Hexiwear. It features an open-source OpenSDA compatible programmer, and the familiar set of buttons, LEDs, and connectors, available on many MikroElektronika development systems. It's a proven concept that allows ultra-rapid development, based on the WYSIWYG principle: What You See Is What You Get. By embracing the open-source concept, Hexiwear, and the Hexiwear Workstation open even more possibilities, allowing you to share ideas and get help with your project from a great community gathered around the Hexiwear platform.



Nebojsa Matic,
Owner and General Manager
of MikroElektronika

Table of contents

Introduction	4
Power supply	6
Connector	8
Hexiwear	10
mikroProg	11
Programming	14
Connectivity	17
Other modules	23
What's Next?	30

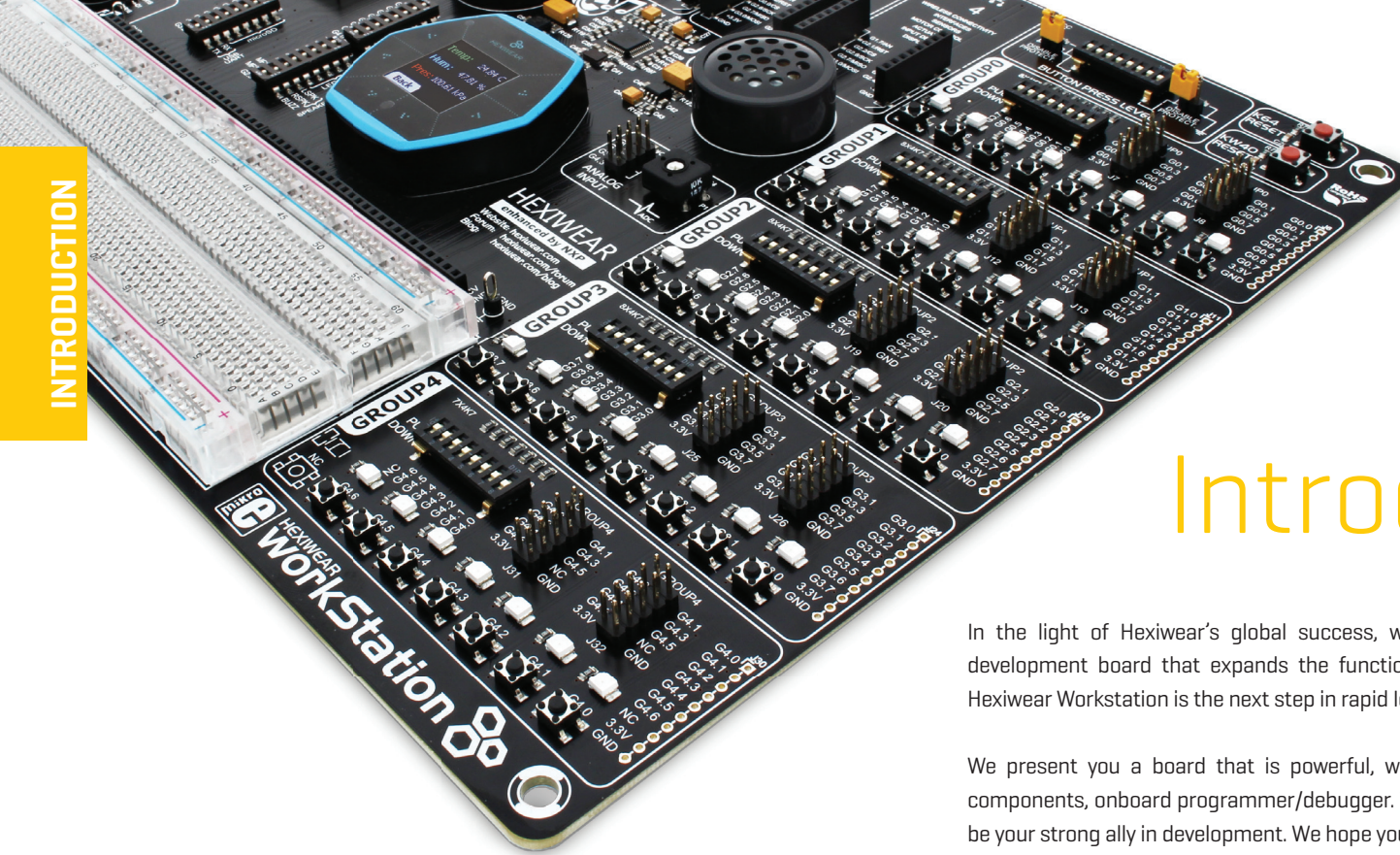

Introduction

In the light of Hexiwear's global success, we decided to make a full-featured development board that expands the functionality of your favorite IoT tool. The Hexiwear Workstation is the next step in rapid IoT prototyping.

We present you a board that is powerful, well organized, featuring high-quality components, onboard programmer/debugger. The Hexiwear Workstation is ready to be your strong ally in development. We hope you will enjoy it as much as we do.

Hexiwear Workstation Development Team

PERFECT FOR LEARNING

The Hexiwear Workstation development board supports Hexiwear - a wearable development platform, powered by the NXP Kinetis K64F MCU, an ARM® Cortex® M4 MCU working at 120 MHz, with 1M flash and 256K SRAM. Experiment with ease, observe results on the LEDs, hook up additional peripherals, or use the protoboard area to create a custom circuit.

HEXIWEAR WITH WIRES

Hexiwear Workstation allows you to connect Hexiwear to the outside world. Buttons, LEDs and three headers for each group of pins, are the connectivity arsenal you need. The Hexiwear Workstation expands the possibilities of Hexiwear itself, allowing all of its pins to be used in a simple and intuitive way.

DEBUGGER ON BOARD

Powerful onboard mikroProg OpenSDA programmer and In-Circuit debugger can program and debug a docked Hexiwear. It opens a door to many possibilities. Once you use an OpenSDA compatible programmer, you will not be able to imagine development without it ever again.

FOUR mikroBUS™ SOCKETS

Four additional mikroBUS™ sockets allow interfacing with hundreds of different Click boards™. The number of available Click boards™ grows daily. Simply snap in your Click board™, and add a new functionality to your project. Our engineers provide you with tools that simplify your development.

It's good to know

SYSTEM SPECIFICATIONS



POWER SUPPLY
7-23V AC or 9-32V DC
or via USB cable [5V DC]



POWER CONSUMPTION
~30mA
[no docked Hexiwear]



BOARD DIMENSION
266 x 220 mm
[10.47 x 8.66 inch]



BOARD WEIGHT
490g
[1.080 lbs]

PACKAGE CONTAINS

1

Damage resistant protective box



2

Hexiwear Workstation development board

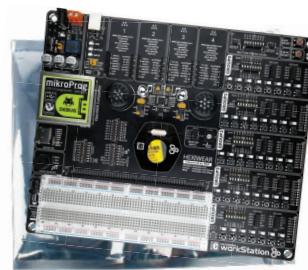

3

USB cable



4

Wire jumpers



5

User Manual



6

Board schematic



Power Supply

The Hexiwear Workstation board features an efficient and clean power supply, which provides steady voltage levels and current, necessary for powering each part of the board. To power on the board, it is necessary to turn the ON/OFF switch to ON position, located at the top left corner of the board. The power presence is indicated by the green LED indicator, located next to the switch. Once powered, the Hexiwear Workstation board will supply the connected (docked) Hexiwear platform with the power, charging its internal battery. Please note that the power consumption will be greater than specified, while the battery of the docked Hexiwear is charging.

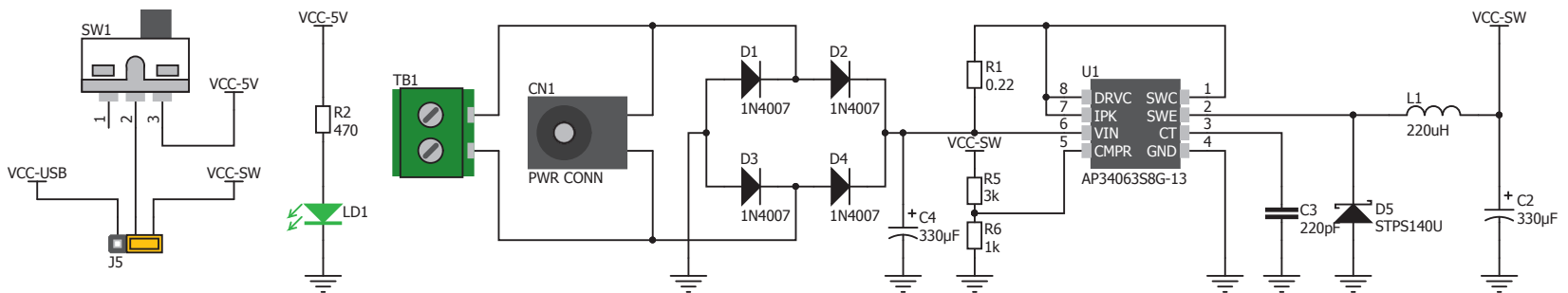

Figure 1: Power supply schematic

How to power the board?



The Hexiwear Workstation board features an efficient and clean power supply, which provides stable voltage and current levels, necessary for powering each part of the board.

POWER SUPPLY:

Via DC connector or screw terminals (7V to 23V AC or 9V to 32V DC), or via USB cable (5V DC).

POWER CAPACITY:

Up to 500mA with USB, and up to 1.6mA with external power supply.

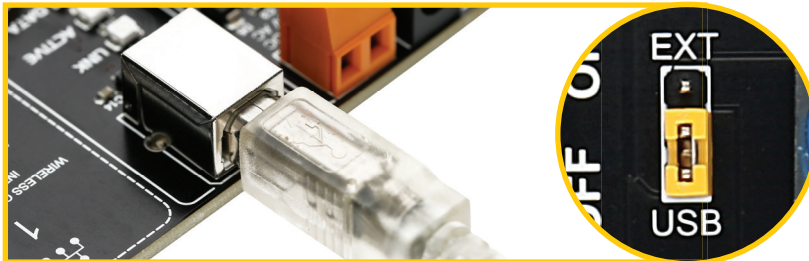

Figure 2: Powered by USB

1. With USB cable

To power the board with USB cable, jumper J5 should be placed in USB position (Figure 2). After that, the USB cable can be plugged in, as shown on images 1 and 2. The Hexiwear Workstation board is now ready to be powered ON by using the power switch [SW1].

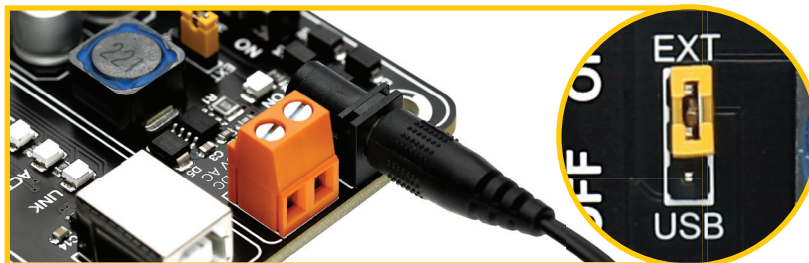

Figure 3: Powered by wall-adaptor

2. By using wall-adaptor

To power the board via the barrel connector, jumper J5 should be placed in EXT position (Figure 3). After that, the power cable can be plugged in, as shown on images 3 and 4. The Hexiwear Workstation board is now ready to be powered ON by using the power switch [SW1].

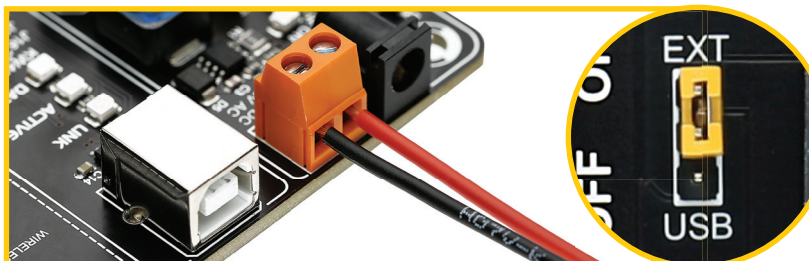

Figure 4: Powered by laboratory PSU

3. With laboratory power supply

To power the board via the screw terminal, jumper J5 should be placed in EXT position (Figure 4). After that, the power cable can be fastened by the terminal screws, as shown on images 5 and 6. The Hexiwear Workstation board is now ready to be powered ON by using the power switch [SW1].

Hexiwear docking connector

Hexiwear Workstation board is equipped with a small male mezzanine connector, which is used to interface the Hexiwear platform with the board. The small female mezzanine connector on the back of Hexiwear contains all the GPIO pins, I2C bus pins, SPI bus pins, power supply pins, and programming pins available on Hexiwear platform. To dock Hexiwear, it is enough to position it above the Hexiwear outline print on the board and gently press it, until the connectors are securely coupled.

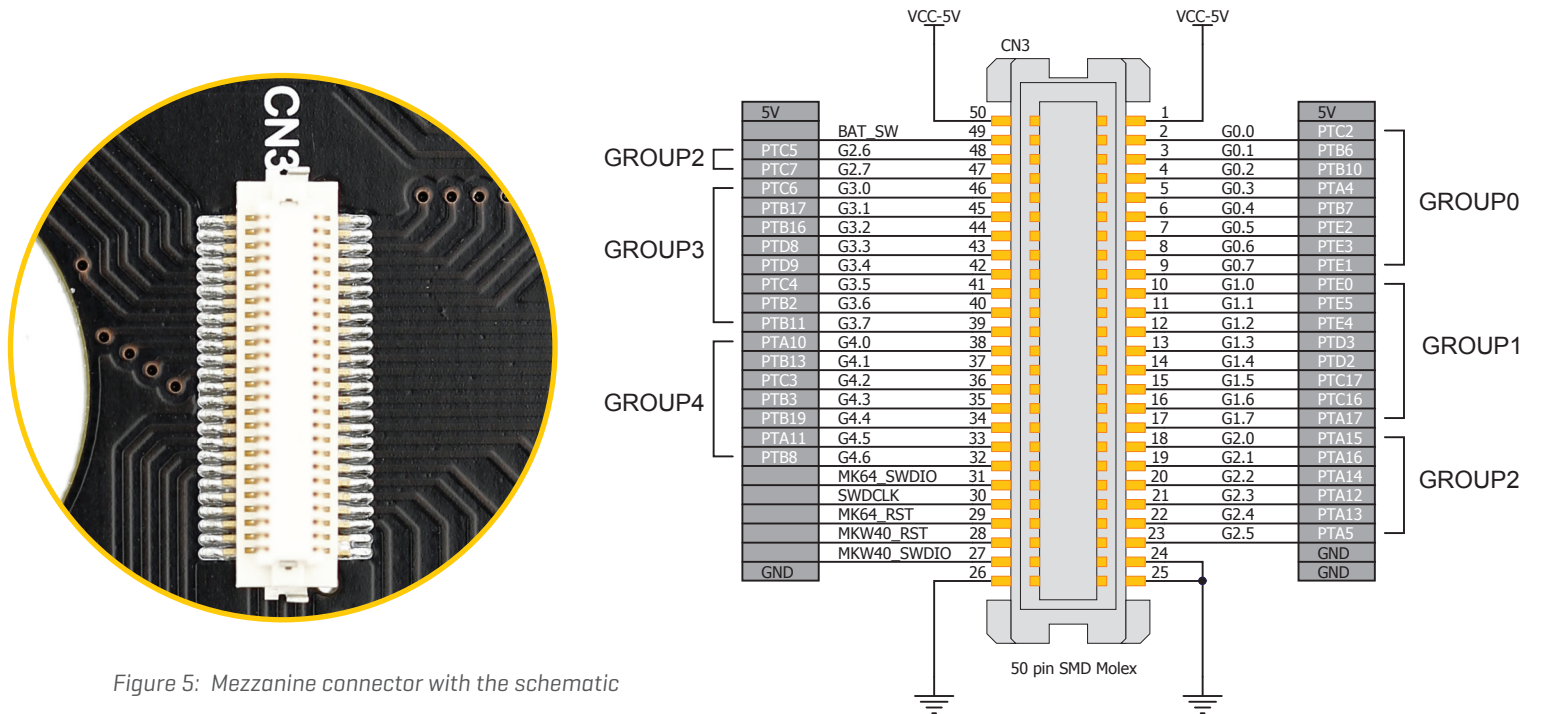

Figure 5: Mezzanine connector with the schematic

NOTE: Don't apply too much force on Hexiwear when docking it, as too much pressure might lead to a physical damage to the device.

How to properly dock Hexiwear?

Before docking Hexiwear, the power supply should be turned off. Images below show how to correctly dock Hexiwear. First, make sure that the orientation of the female mezzanine connector matches the position of the connector on the Hexiwear Workstation board. Place Hexiwear above the printed hexagonal marking on the workstation board, as shown in Figure 7. Slowly move Hexiwear down towards the board, until connectors make contact. Making sure that the alignment of the connectors is good, gently press Hexiwear, until contacts are firmly coupled, as shown in Figure 7. Now the power can be turned back ON.



1 Figure 6:
Hexiwear Workstation board has printed markings, which are useful to correctly position the Hexiwear before docking



2 Figure 7:
Make sure that the female connector of the Hexiwear is properly oriented in respect to the male counterpart on the Workstation board



3 Figure 8:
Properly docked Hexiwear



About Hexiwear

Hexiwear combines style and usability found in high-end consumer devices, with functionality and expandability of sophisticated engineering development platforms - an ideal form factor for IoT edge node and wearable markets. Completely open source and developed by MikroElektronika in partnership with NXP, Hexiwear includes a low power, high performance Kinetis® K64F microcontroller based on ARM Cortex-M4 core, the Kinetis KW40Z multimode radio SoC, and support for BLE. Hexiwear features 6 onboard sensors including Optical Heart Rate Monitor, Accelerometer, Magnetometer, Gyroscope, Temperature, Humidity, Light and Pressure sensors, with a color OLED display and rechargeable battery. Supported with application for Android and iOS, developers can connect the device to the cloud out of the box, without any additional software development.

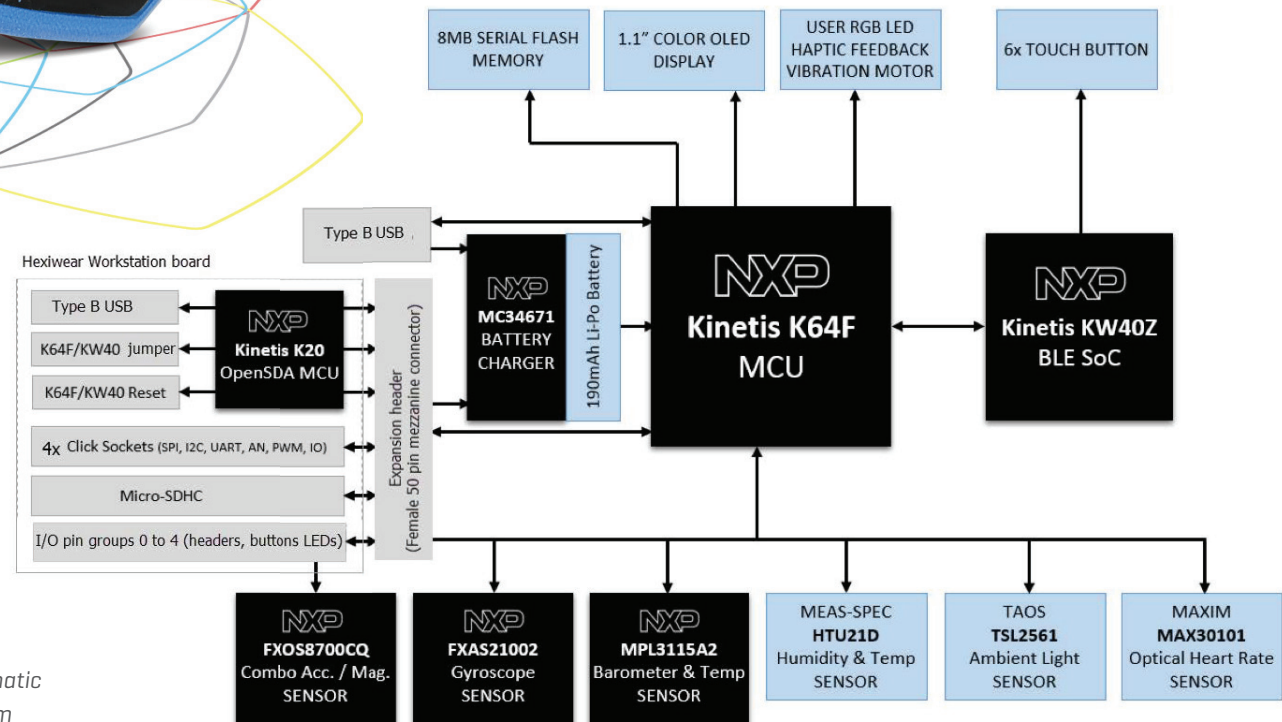

Figure 9: Block schematic of the Hexiwear system

Onboard programmer

What is mikroProg?

The Hexiwear Workstation board is equipped with the mikroProg, an onboard OpenSDA compatible programmer and hardware in-circuit debugger for Kinetis MCUs. It is used to program and debug docked Hexiwear. The programmer allows seamless programming and debugging operations directly from within the mikroC PRO for ARM, mikroPascal PRO for ARM, or mikroBasic PRO for ARM compilers, as well as using it with the stand-alone programming application, called mikroProg Suite. It also supports the DAPLink programming method, which offers an easy to use drag&drop based programming of the docked Hexiwear platform.

About OpenSDA

OpenSDA is an open-standard serial and debug adapter. It allows serial and debug communications between a USB host and an embedded microcontroller (K64F and KW40Z in case of Hexiwear). Hexiwear Workstation has an integrated OpenSDA compatible programmer on board. The hardware circuit of the programmer is based on the NXP Kinetis K20 family MCU and an integrated USB controller. This programmer offers several distinctive features, with more planned to be developed in the future:

- It features a Mass Storage Device class interface [MSD] - The programmer appears as a mass storage device, which can be used to program the docked Hexiwear by simple drag&drop of the binary (.bin) or hex (.hex) files to the mass storage folder.
- It features a USB Communications Device class [CDC] - The programmer exposes its UART component as the COM port on a Windows platform.
- It provides a channel over which the CMSIS-DAP debug protocol runs. This allows compilers to use the OpenSDA compatible programmer to debug the application software in compilers which support it.

If you want to know more about the OpenSDA project, be sure to read the OpenSDA user guide on the link below: nxp.com/docs/en/user-guide/OPENSDAUG.pdf

How do I start?

Before using the Hexiwear Workstation board for the first time, it is necessary to take the following steps:

- Install the required software:
 - Install USB drivers [Page 20]
 - Install mikroProg Suite for ARM® software [Page 21]
- Power up the board:
 - Plug in the programmer USB cable
 - Turn on Power switch
 - LINK and POWER LED should light up.

Why so many LEDs?

These three LEDs indicate specific programmer operations (Figure 10). Link LED lights up when USB link is established. Active LED lights up when programmer is active. Data LED lights up when data is being transferred between the programmer and the host computer.

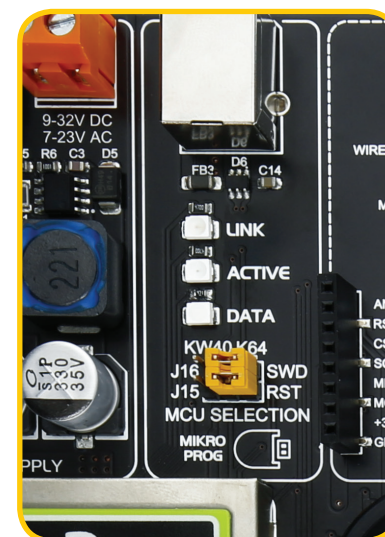
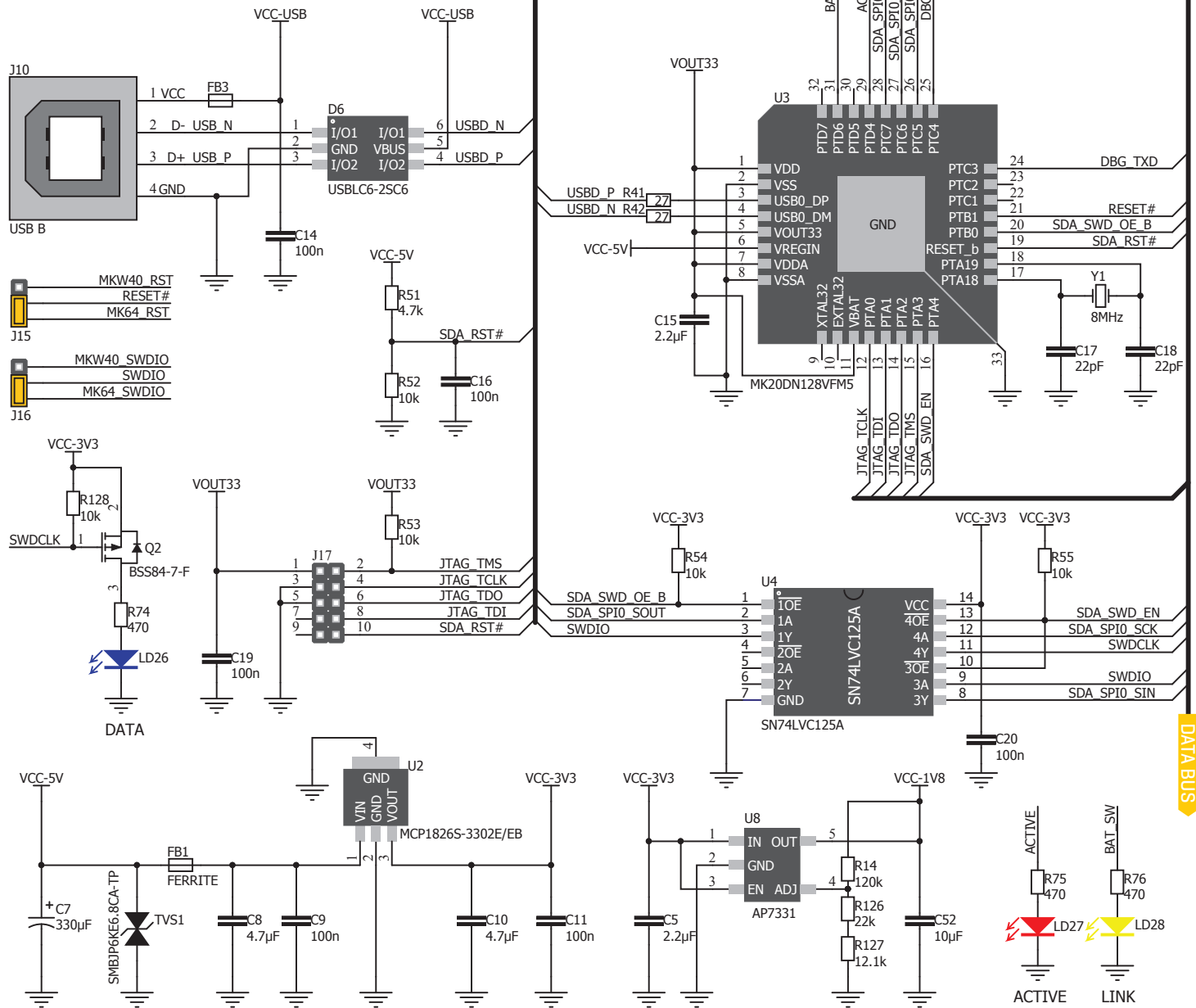

Figure 10: Programmer LEDs

Figure 11:
mikroprog Schematic



Installing programmer drivers

Drivers installation

When working in Windows, the onboard mikroProg OpenSDA compatible programmer requires an appropriate driver to be installed. This driver allows full functionality of the onboard programmer, as well as adding the mbed virtual COM port capability to the system. To properly install the driver, several simple steps should be followed:

1. **Download the Arm mbed Windows serial port driver from the link below**
2. **Plug in your Arm Mbed device over USB. It mounts as an Mbed drive**
3. **Close all Explorer windows showing the Mbed drive**
4. **Run the installer. This may display a few “unsigned driver” warnings, just press NEXT**

The detailed installation procedure along with the necessary drivers and troubleshooting tips, can be found on the os.mbed.com official site:

os.mbed.com/docs/latest/tutorials/windows-serial-driver.html

Also, all the required files can be found on the Hexiwear Workstation product page, from the link below: www.mikroe.com/hexiwear-workstation

Configuring the mikroProg

Since Hexiwear has two programmable devices (Kinetis K64F MCU and Kinetis KW40Z BLE SoC) the target device for the programmer should be properly selected. Most of the time, K64F MCU will be the target device for the programmer, since it is used to run the software applications, but when required, the programmer can be redirected to program the KW40Z. This is done by simply moving the J15 and J16 jumpers (Figure 12) to the appropriate position: right position for K64F, left position for KW40Z. Jumper J15 redirects the RST line of the selected device, while the jumper J16 redirects the SWD line of the selected device, to the onboard mikroProg programmer.



Figure 12:
Target MCU selection jumpers

Programming Software

mikroProg Suite for ARM®

Onboard mikroProg programmer requires special programming software called mikroProg Suite. This software is used to program both K64F and K40Z devices, and it can be used either as the stand-alone application or it is automatically launched from within the mikroC PRO, mikroBasic PRO, or mikroPascal PRO for ARM® compiler, when “build and program” button is pressed. Software has a clean and intuitive interface, and features the SingleClick technology, that allows programming with just a single button click! To begin the mikroProg Suite installation process, first download the necessary installation file from the product page, on the following link: www.mikroe.com/hexiwear-workstation

Extract the downloaded archive to a folder, and locate the extracted executable setup file. Double click on it to start the installation. The installation wizard offers a guidance through the installation process. Once the installation of the suite is complete, it is necessary to select the proper MCU type. This is done by clicking the OPTIONS button from the main application window, and then selecting the “NXP” item from the drop-down menu, labeled as “Hardware”. After confirming the settings with the OK button on the bottom of this window, the board is ready to be used.

Installation wizard - 6 simple steps

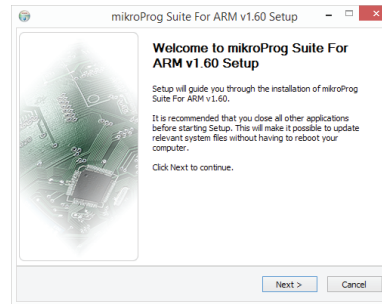

Step 1 - Start Installation

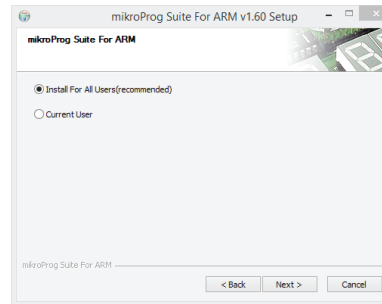

Step 3 - Install for All users or current user

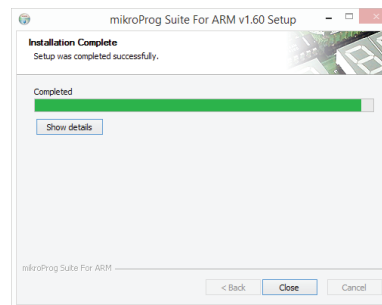

Step 5 - Installation in progress

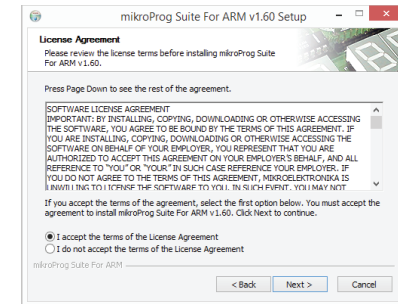

Step 2 - Accept EULA and continue

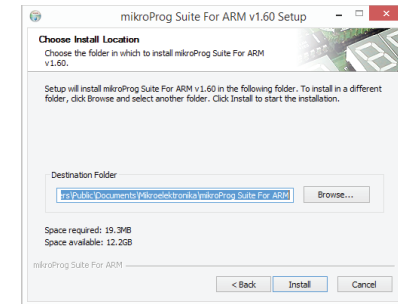

Step 4 - Choose destination folder

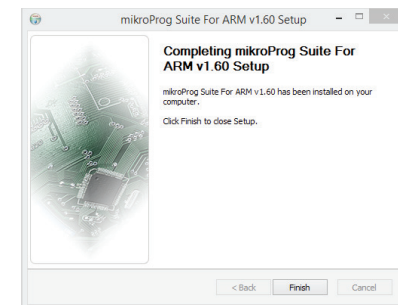

Step 6 - Finish Installation

In Circuit Debugger

What is Debugging?

Every developer comes to a point where he has to monitor the code execution in order to find errors in the code, or simply to see if everything is going as planned. This hunt for “bugs”, or errors in the code, is called debugging. There are two methods of debugging: The first method is Software debugging method, which only simulates what is supposed to be happening on the micro-controller as the code lines are executed. The second method is Hardware debugging, and it allows monitoring of the program execution on the MCU itself. The software application is executed on the target device, instead being simulated by the compiler. This method allows insight into the internal states of the MCU, while it runs the program code.

Using mikroProg for debugging

The onboard OpenSDA compatible programmer provides hardware debugging method, by utilizing the OpenSDA interface. The debugger allows controlled execution of the software application on the MCU. It offers a preview of the used variables content, states of the special function registers [SFR], values in various memory locations, and more, while the program is executed on the MCU. It supports step-over, step-into, step-out, run, and run to cursor debugging operations, as well as using of standard breakpoints. Whether you are a beginner, or a professional, this powerful tool, with intuitive interface and convenient set of commands, will enable you to quickly track down bugs. OpenSDA compatible mikroProg programmer offers.

Supported Compilers

All MikroElektronika ARM® based compilers - mikroC PRO, mikroBasic PRO, or mikroPascal PRO, natively support mikroProg™ OpenSDA compatible debugger. Specialized DLL module allows compilers to exploit the full potential of the fast hardware debugging. Along with compiler of your choice, make sure to install the appropriate mbed serial drivers, and mikroProg Suite for ARM® programming software, as described on pages 20 and 21.

How to use the debugger?

When you build your project for debugging, and program the microcontroller with this HEX file, you can start the debugger using [F9] command. Compiler will change layout to debugging view, and a blue line will mark where the code execution is currently paused.

You can use the debugging toolbar in the Watch Window, or shortcut keys to guide the program execution, and stop anytime. Add the desired variables to Watch window and monitor their values. Complete guide to using the debugger is provided in the Help section of the MikroElektronika compilers.

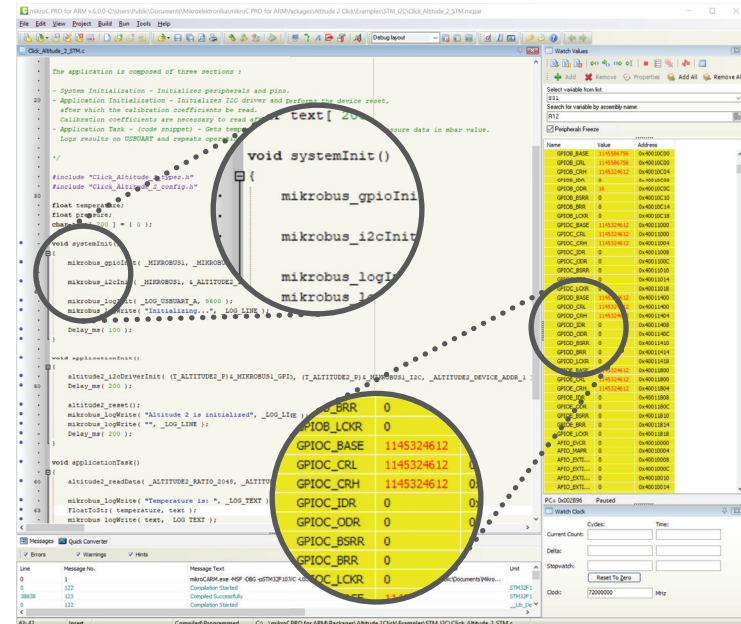

Debugger Commands



Here is a short overview of which debugging commands are supported in MikroElektronika compilers. You can see what each command does, and what are their shortcuts when you are in debugging mode. It will give you some general picture of what your debugger can do.

ICONS	COMMAND NAME	SHORTCUT	DESCRIPTION
	Start Debugger	[F9]	Starts Debugger.
	Run/Pause Debugger	[F6]	Run/Pause Debugger.
	Stop Debugger	[Ctrl + F2]	Stops Debugger.
	Step Into	[F7]	Executes the current program line, then halts. If the executed program line calls another routine, the debugger steps into the routine and halts after executing the first instruction within it.
	Step Over	[F8]	Executes the current program line, then halts. If the executed program line calls another routine, the debugger will not step into it. The whole routine will be executed and the debugger halts at the first instruction following the call.
	Step Out	[Ctrl + F8]	Executes all remaining program lines within the subroutine. The debugger halts immediately upon exiting the subroutine.
	Run To Cursor	[F4]	Executes the program until reaching the cursor position.
	Toggle Breakpoint	[F5]	Toggle breakpoints option sets new breakpoints or removes those already set at the current cursor position.
	Show/Hide breakpoints	[Shift+F4]	Shows/Hides window with all breakpoints
	Clears breakpoints	[Shift+Ctrl+F5]	Delete selected breakpoints
	Jump to interrupt	[F2]	Opens window with available interrupts

Input/Output Group

One of the most distinctive features of Hexiwear Workstation board are the Input/Output groups. These groups contain buttons, LEDs and headers, routed to the pins of the docking connector. They allow interaction with the docked Hexiwear, either by pressing buttons, displaying states of its pins on the LEDs, or using headers to interface it to an external device.

Everything is grouped together

The pins of the Hexiwear docking connector are arranged in groups. There are 5 groups with 8 pins routed to the Hexiwear docking header, in each. All the pins are marked with the label that clearly identifies to which group a particular pin belongs: for example, G1.4 means that the specific pin is the pin number 4 in the I/O group 1. Pins and groups are labeled starting with 0. This concept makes development easier, and makes the entire Hexiwear Workstation clean and well organized.

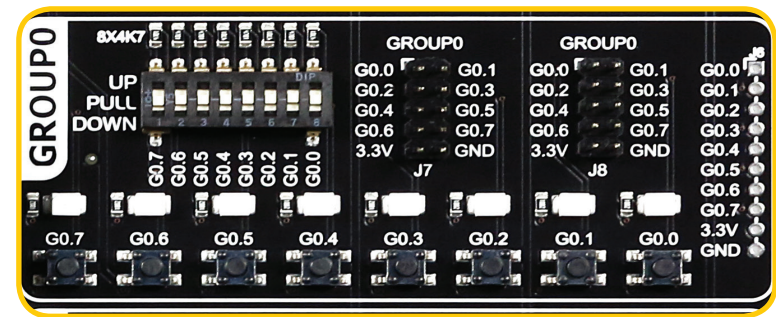
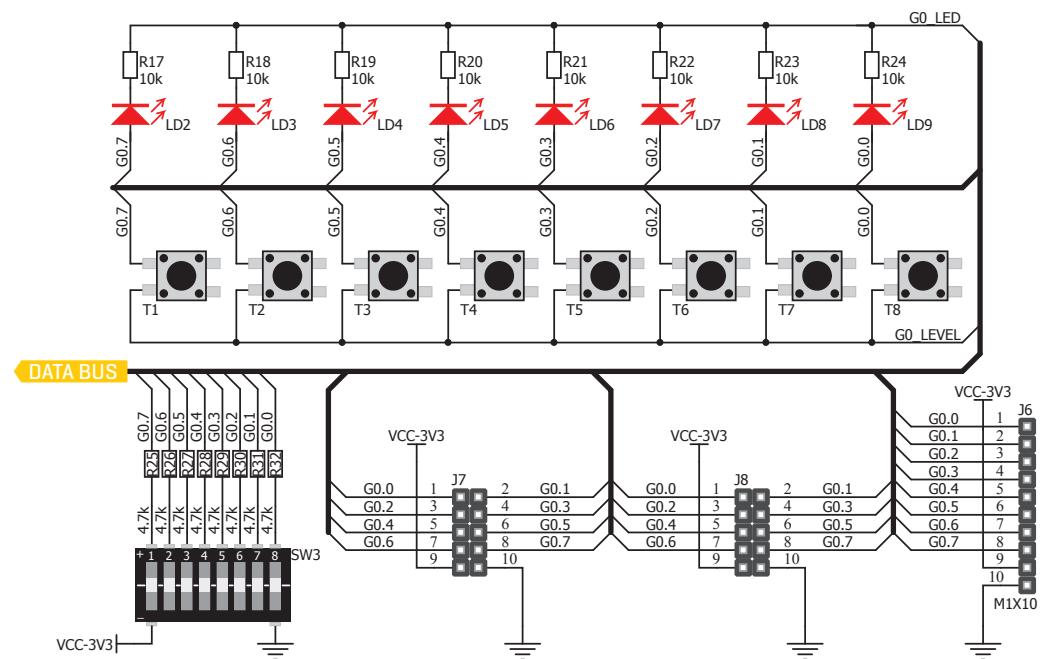

Figure 13: I/O group with the schematic

Tri-state pull-up/pull-down DIP switches

Tri-state DIP switches, like the SW3 on Figure 13, are used to enable 4K7 pull-up or pull-down resistor on any desired pin. Each I/O group has one such DIP switch, which enables these pull-up/pull-down resistors on pins of the particular group. These DIP switches can have three states:

1. **MIDDLE POSITION:** disconnects both the pull-up and pull-down resistors from a selected group pin
2. **UP POSITION:** connects the pull-up resistor to a selected group pin.
3. **DOWN POSITION:** connects the pull-down resistor to a selected group pin.



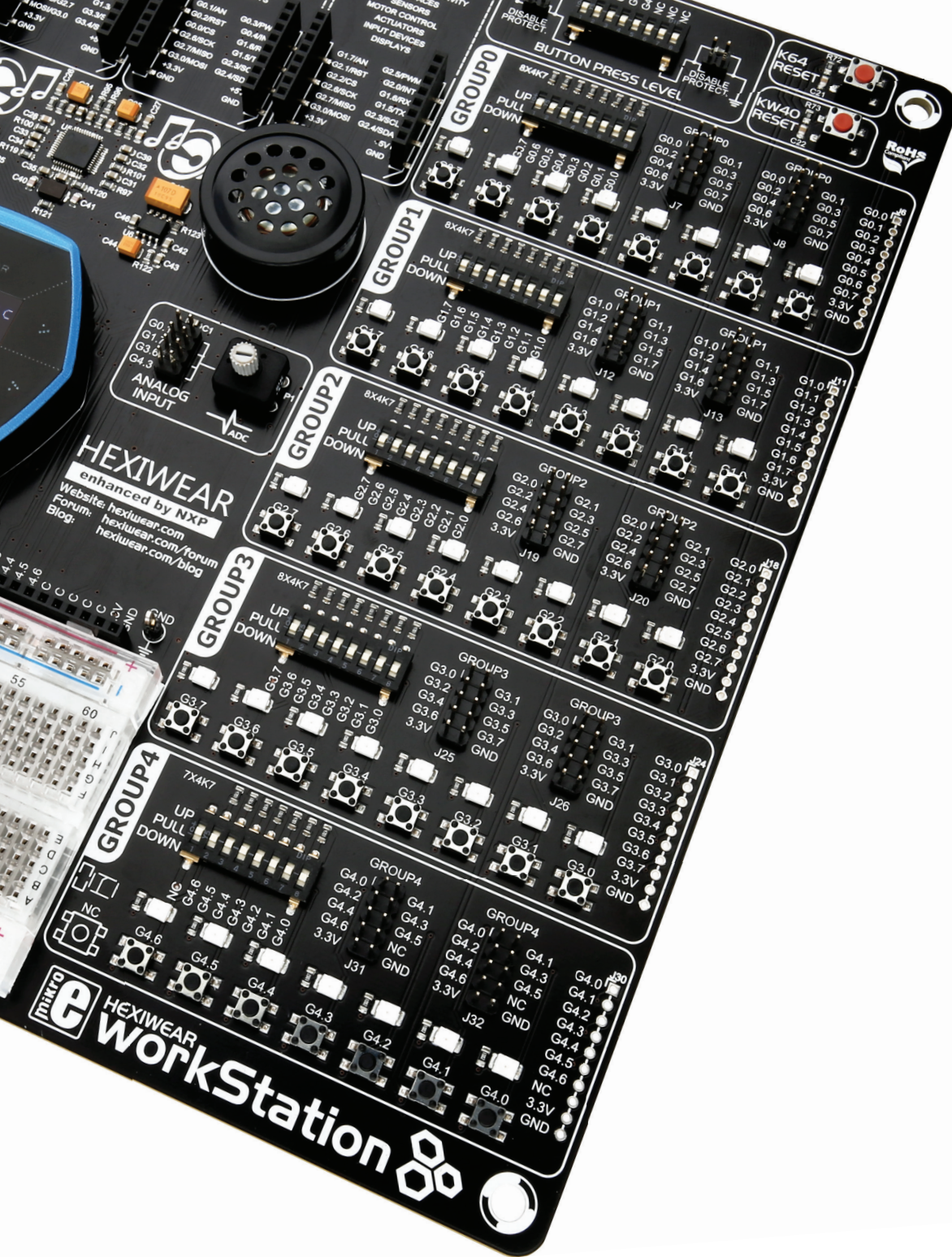

HEADERS

With enhanced connectivity as one of the key features of the Hexiwear Workstation, we have provided three connection headers for each group. Each I/O group contains two male IDC10 headers and a row of 10 PCB pads (Figure 14).

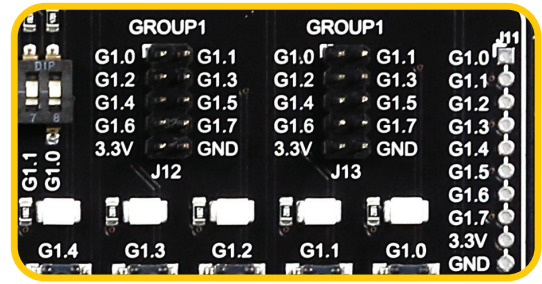

Figure 14: Headers

IDC10 male headers enable easy connection with MikroElektronika add-on boards (Figure 15).

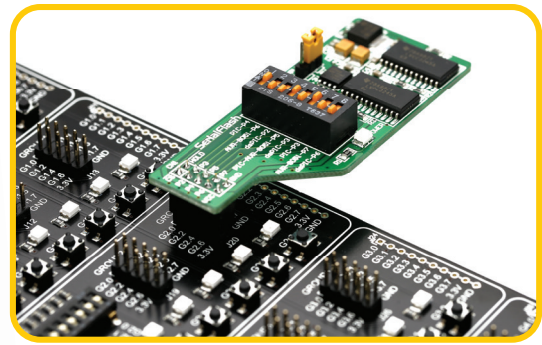

Figure 15: IDC10 male headers

BUTTONS

The logic state of all Hexiwear digital inputs may be controlled using the push buttons [Figure 16].



Figure 16: I/O group push buttons

Each I/O group has 8 buttons. The tri-state DIP switch, labeled as “BUTTON PRESS LEVEL” [SW7], is available for selecting which logic state will be applied to the corresponding group pins, when the button is pressed. Each of the SW7 DIP switches controls the behavior of the entire group to which it is assigned [G0 to G4] [Figure 17]

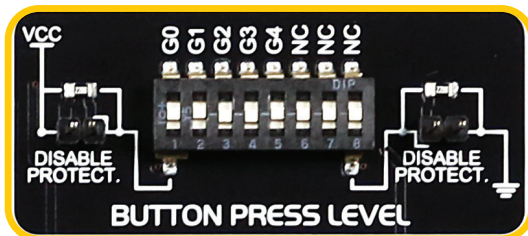

Figure 17: Button press level DIP switch

For example, If the SW7.1 switch is in the up position, then pressing any button in group 0 will apply a logic HIGH state to the corresponding pin, connecting it to the VCC via the 220 ohm resistor, used for protection. The same principle applies for down position, but this time, a logic LOW state will be applied. If DIP switch is in the middle position, neither of two logic states will be applied, and the pin

Hexiwear Workstation

is left to float. Shorting jumpers J22 for up position [and J23 for down position, respectively], will bypass the 220 ohm resistor, allowing buttons to connect pins to VCC [or GND], directly.

LEDs

Hexiwear Workstation board contains 8 LEDs in each group [except the group 4, which has 7 LEDs], which can be used for visual indication of the logic state on each pin. [Figure 18] An active LED indicates that a logic HIGH level [logic 1] is present on the pin. In order to enable LEDs on a specific group, it is necessary to set the corresponding switch ON.



Figure 18: I/O group LEDs

Switches SW4.1 to SW4.5 are used to turn on LED functionality for each group, respectively. To protect both LEDs and the Hexiwear platform itself, every LED is connected to group pins via the 10K resistor, limiting the current to an acceptable level. [Figure 19]

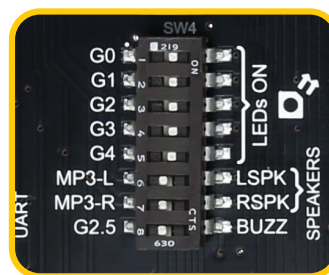

Figure 19:
SW4.1 through
SW4.5 switches
are used to
enable group
LEDs

Reset Buttons

Hexiwear Workstation board features two reset buttons, which can be used to manually reset the respective MCUs of the docked Hexiwear [Figure 20]. Holding K64W RESET button while powering the system, will boot the DAPLink programmer in the MAINTENANCE mode. This allows re-programming of the onboard OpenSDA programmer, in case when the internal programmer firmware has been damaged, for any reason.



Figure 20: Reset buttons

mikroBUS™ sockets

Easy connectivity and simple configuration are imperative in the world of modern embedded electronics. For example, the success of the USB standard comes from its simplicity and high and reliable data transfer rates. This is why our engineers have come up with a brilliant solution for rapid development, in the form of a simple, yet powerful standardized interface. It contains bus lines, which most of modern devices use, almost completely eliminating the need for any additional hardware configuration. This standardized connection interface is called mikroBUS™. More about the mikroBUS™ standard can be found on our official mikroBUS™ page: www.mikroe.com/mikrobus

Hexiwear Workstation comes equipped with four mikroBUS™ sockets (Figure 21), expanding the connectivity to a selection of hundreds of different devices, including displays, buttons, motor drivers, LED drivers, BT radios, GPS, GSM, WiFi, and many more, with new ones produced almost daily. All these devices are neatly packed onto the standardized PCB that perfectly fits in the mikroBUS™ socket. It is called Click board™, because it simply “clicks” into the mikroBUS™.

- AN** - Analog pin
- RST** - Reset pin
- CS** - SPI Chip Select line
- SCK** - SPI Clock line
- MISO** - SPI Slave Output line
- MOSI** - SPI Slave Input line
- +3.3V** - VCC-3.3V power line
- GND** - Reference Ground
- PWM** - PWM output line
- INT** - Interrupt line
- RX** - UART Receive line
- TX** - UART Transmit line
- SCL** - I2C Clock line
- SDA** - I2C Data line
- +5V** - VCC-5V power line
- GND** - Reference Ground

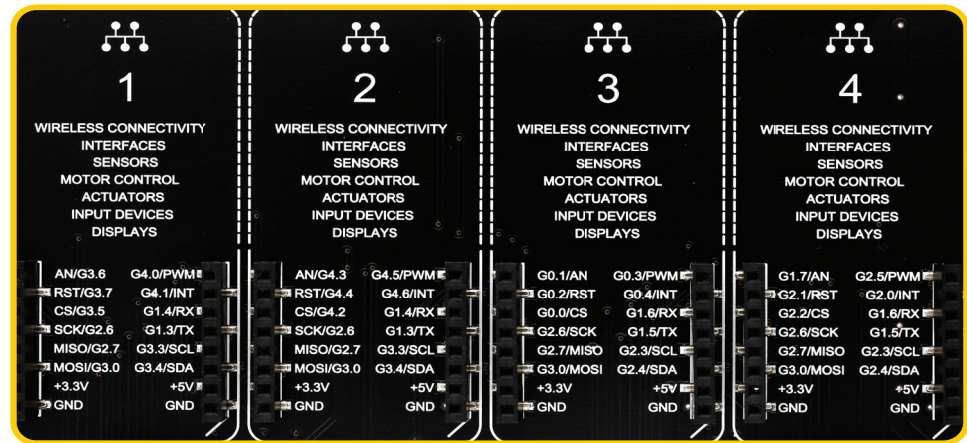

Each mikroBUS™ socket consists of two 1x8 female headers containing pins that are most likely to be used on most of the target devices. There are three groups of communication pins available: SPI, UART and I2C. There are also pins for PWM, Interrupt, Analog input, Reset and Chip Select, and two power supply rails available: +5V and GND on one side and +3.3V and GND on the other side of the mikroBUS™ socket.

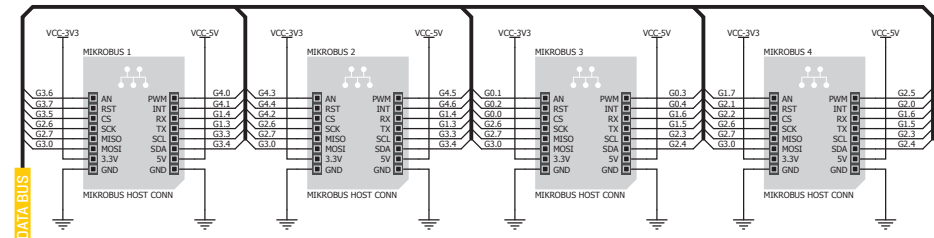
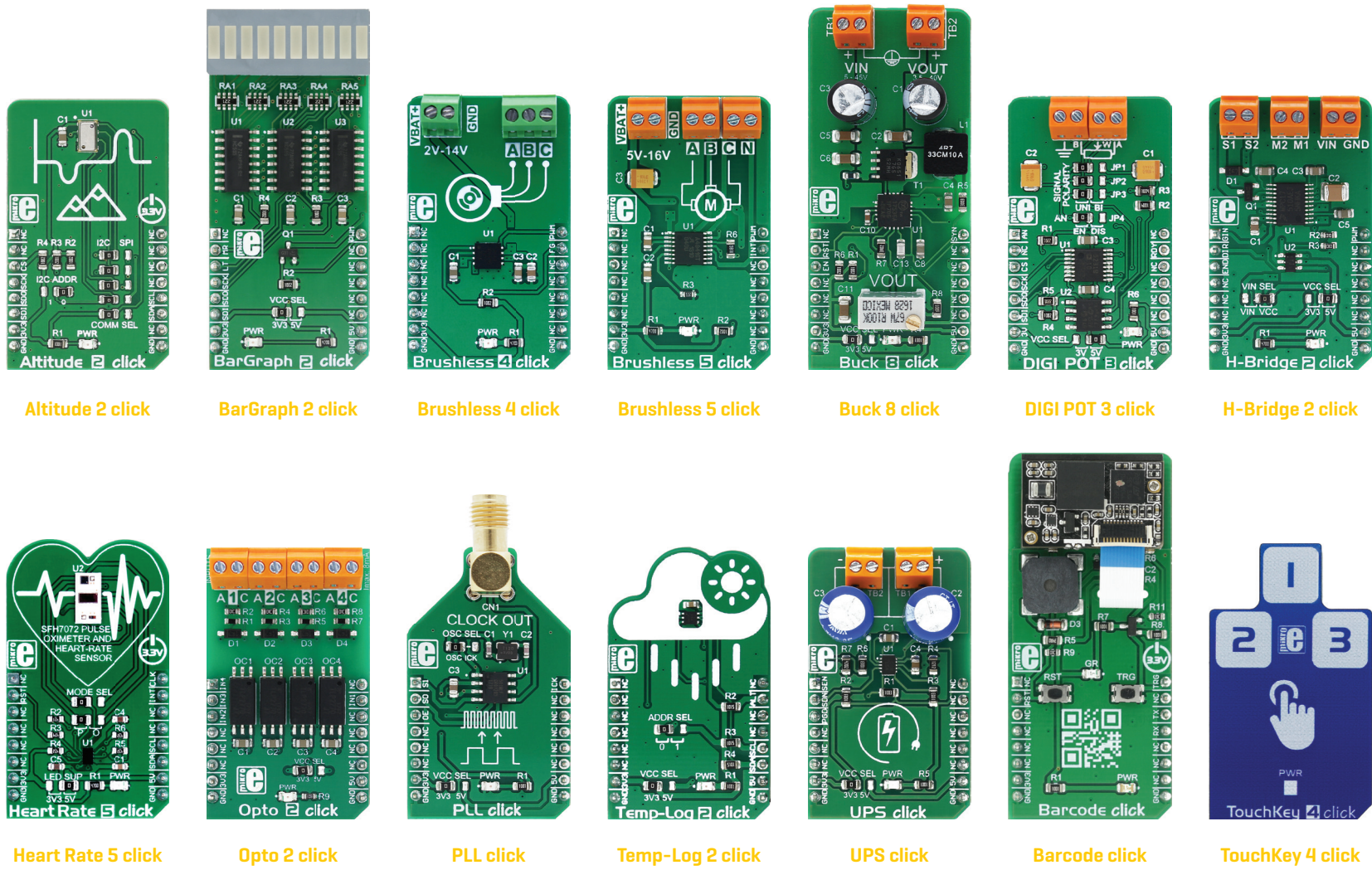

Figure 21: mikroBUS™ sockets with the schematic

Click Boards™ are plug-n-play!

Click boards™ are standardized printed copper boards (PCB) that carry a variety of different electronic devices. They are designed to perfectly fit in the mikroBUS™ socket. Engineered to deliver the best performances for the used components, they save developers of testing and troubleshooting, often associated with the prototyping phase, offering rapid development and faster times to market. These ready-to-use boards require no additional hardware configuration. More information about the Click boards™ can be found on the following link: www.mikroe.com/click



Altitude 2 click BarGraph 2 click Brushless 4 click Brushless 5 click Buck 8 click DIGI POT 3 click H-Bridge 2 click

Heart Rate 5 click Opto 2 click PLL click Temp-Log 2 click UPS click Barcode click TouchKey 4 click

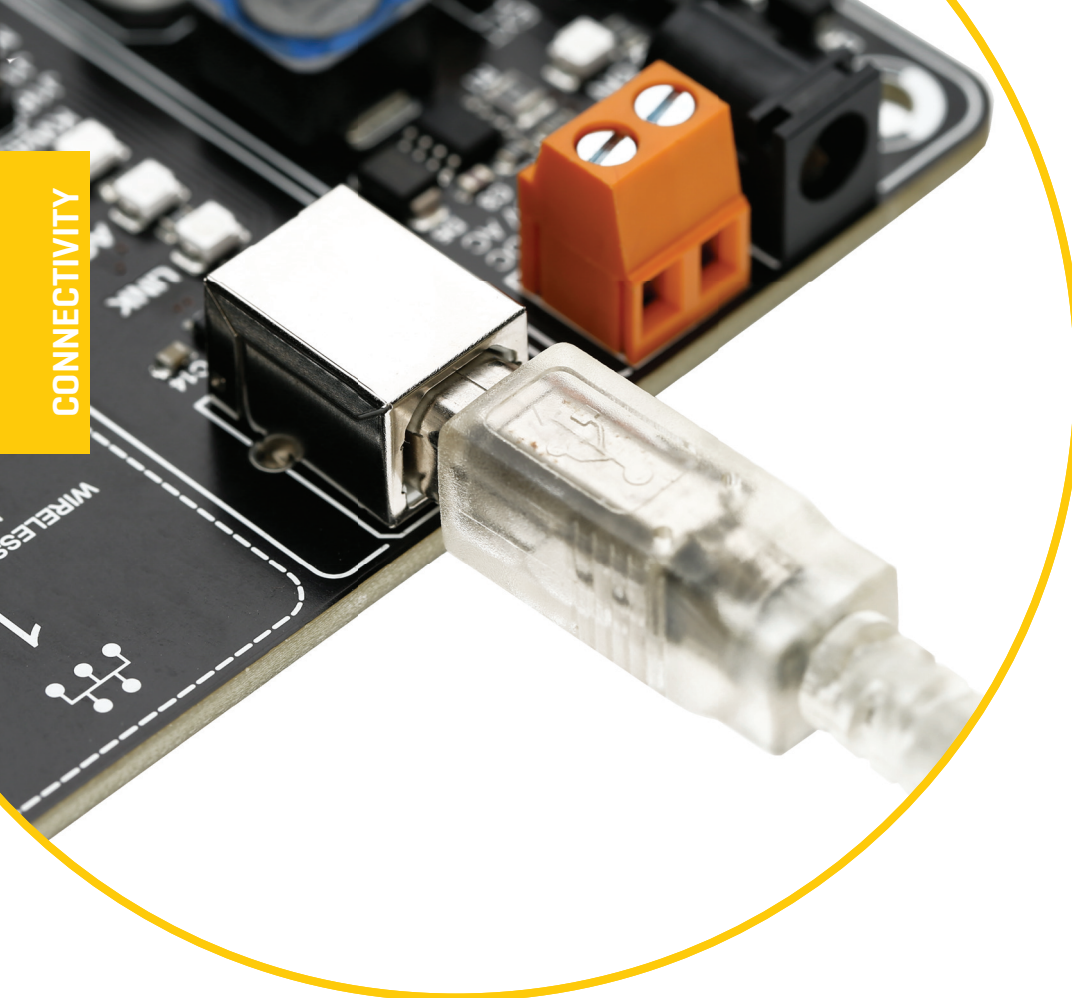

UART via USB

Hexiwear Workstation board contains aforementioned OpenSDA compatible programmer, which among other features, offers a virtual COM port emulation. This makes possible to use the USB connection of the OpenSDA programmer as the USB to UART adapter. Once the Serial Port drivers are properly installed (see instructions on page 13), the virtual COM port can be selected in your favorite terminal application, and after properly configuring baud rate, stop bits and other UART communication parameters according to your project, the terminal will be available for use.

To verify exactly which virtual COM port was installed on the computer running Windows OS, open the Device Manager and expand the POTRS [COM & LPT] item [Figure 22]. You should be able to see the sub-item labeled as mbed Serial Port [COM 4].

The number in parenthesis represents the COM port number, and it may take any value, depending on the other installed devices (in the example from the picture below, it is COM4).

Enabling USB-UART

In order to enable USB-UART communication, you must push SW2.7 [G3.1] and SW2.8 [G3.2] to ON position. This connects the RX and TX lines to appropriate Hexiwear UART module.

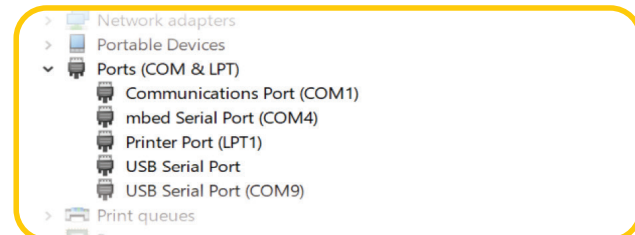
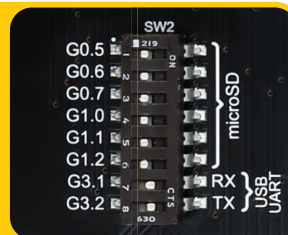

Figure 22: Windows device manager

Audio module

The Hexiwear Workstation comes equipped with two audio amplifiers, capable of delivering up to 675mW of continuous RMS power into two built-in 8-ohm speakers. These amplifiers are used to amplify the line level sound from the VS1053, a stereo MP3 audio CODEC IC. Left and right audio signals from the CODEC IC are routed to the ON/OFF DIP switch, labeled as SW4. By setting SW4.6 and SW4.7 switches ON, the line level audio signal is routed to the amplifiers and thus, speakers. To provide the digital input for the VS1053 IC, another OFF/ON DIP switch [labeled as SW5] has to be used, in order to route all the necessary digital lines that carry the audio information from the docked Hexiwear. By setting switches from SW5.1 [G2.6] to SW5.7 [G2.1] to ON position, the respective pins become routed to VS1053 IC, allowing the sound data to reach the VS1053 IC [Figure 23 and 24].

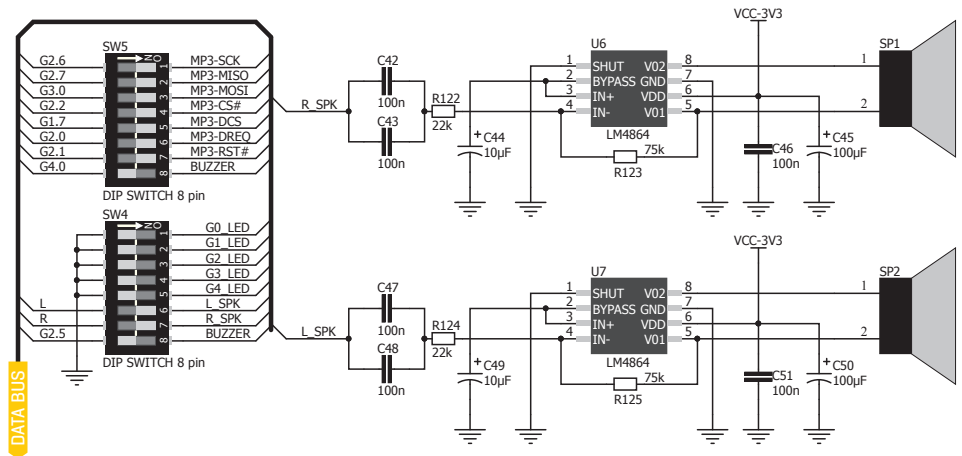

Figure 23: Audio module with the schematic

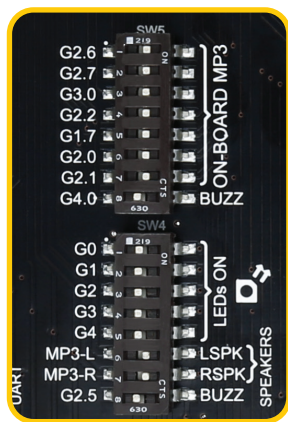
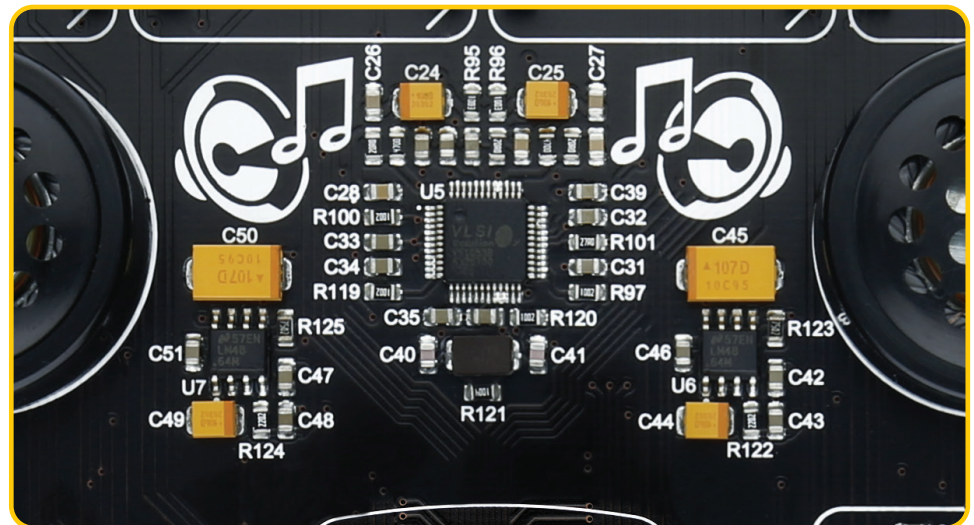

Figure 24: MP3 CODEC and routing to amplifiers



microSD module

Secure Digital cards, SD cards are on the market for quite some time. The standard was first introduced in August 1999 by joint efforts between SanDisk, Panasonic (Matsushita Electric), and Toshiba, as an improvement over existing MultiMediaCards. Since then, several revisions have been made, bringing faster data rates and densities of the SD cards.

Hexiwear Workstation comes equipped with a microSD card reader, allowing docked Hexiwear platform to store data on a mass storage media. microSD card is the smallest version of the SD Cards, with only 5mm in length and 11mm wide. The microSD card reader provides a physical front end for the Secure Digital Host Controller (SDHC) module, integrated in the MK64F MCU of the Hexiwear platform. It allows fast data transfer between the docked Hexiwear platform and the microSD card. It can be used for storing application data, logging various measurements from the Hexiwear sensors, but also from the sensors and other devices, that may be equipped on the mounted Click boards™. The microSD module itself represents only a physical layer - to be able to read and write to the SD Card, a proper software is required.

To allow connection with the microSD onboard module, the appropriate DIP Switch labeled as SW2 has to be set: switches SW2.1 through the SW2.6 allow connection of the corresponding SDHC module pins to the onboard mikroSD card reader module (Figure 25).

DIP SWITCH SW2

It's used to route the appropriate Hexiwear MCU lines to the microSD card module. Turning switches from SW 2.1 [G0.5] to SW 2.6 [G1.2] to ON position will establish a connection between the microSD module and Hexiwear.

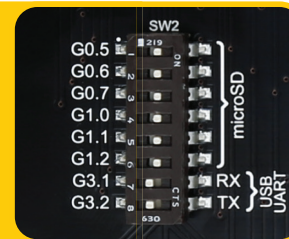
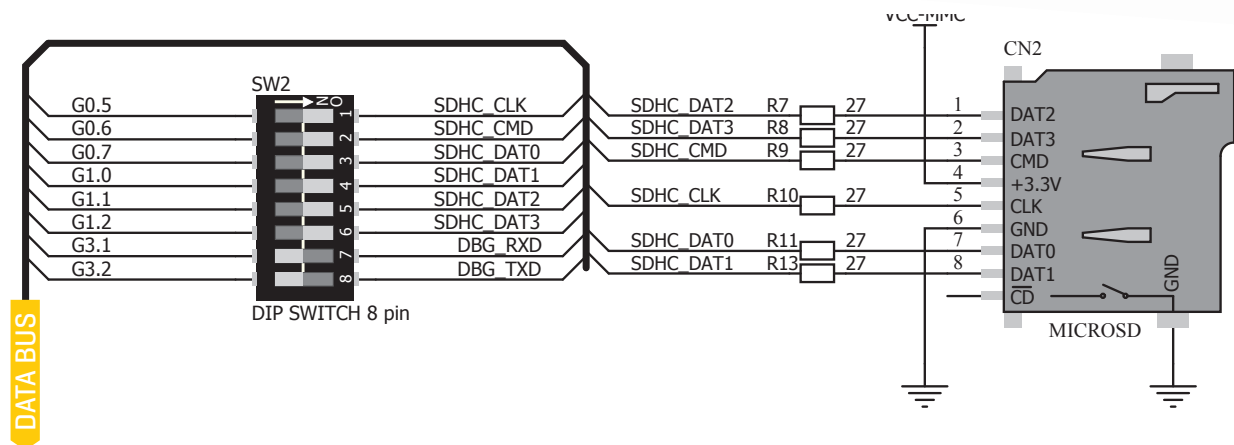

Figure 25: microSD module with the schematic



DS1820 Digital Temperature Sensor

DS1820 is a digital temperature sensor that uses 1-Wire® interface for its operation. It is capable of measuring temperatures within the range of -55 to 128°C, and provides ±0.5°C accuracy for temperatures within the range of -10 to 85°C. It is powered by the 3.3V power rail of the Hexiwear Workstation board. It takes maximum of 750ms for the DS1820 to calculate temperature with 9-bit resolution. 1-Wire® serial communication allows data to be transferred over a single communication line. The main advantage of such communication is that only a single pin is used. It is possible to connect multiple sensors on the same 1-Wire® line. All slave devices by default have a unique ID code, which enables the master to easily identify all slave devices sharing the same line. Board provides a separate socket [TS1] for the DS1820. Communication line is selected with the J2 jumper [Figure 26].

Enabling DS1820 Sensor

Hexiwear Workstation offers 1-Wire® communication between DS1820 and the microcontroller over G0.3 or G4.5 pins. The selection of either of those two lines is done using J2 jumper. When placing the sensor in the socket, make sure that half-circle on the board's silkscreen markings matches the rounded part of the DS1820 sensor. The sensor may become permanently damaged if it is not properly connected. It is a good practice to turn off all unused peripherals that can interfere with the sensor, such as pull-up/pull-down resistors, LEDs, and other devices that could share the 1-Wire® communication line with the DS1820 sensor.

Figure 26: DS1820 with the schematic

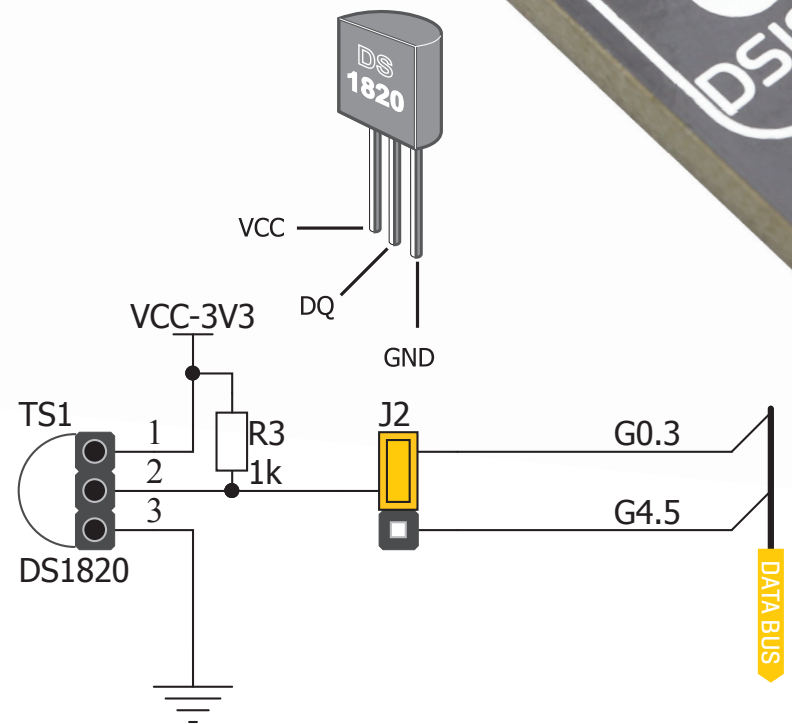



ADC inputs

Digital signals have two discrete states, which are decoded as HIGH and LOW, and interpreted as logic 1 and logic 0. Analog signals, on the other hand, are continuous, and can have any value within defined range. Analog to digital converters [ADC] are specialized circuits, which can convert analog signals [voltages] into a digital form. The digital value of the conversion is linearly dependent on the input voltage value. Most modern microcontrollers have one or more internal ADC sections.

Some of the most important characteristics of the ADC are its conversion time and resolution. Conversion time determines how fast can a sample can be taken - how fast an analog voltage can be represented in the form of a digital value. Resolution represents a number of discrete steps that supported voltage range can be divided into. It determines the sensitivity of the ADC. Resolution is represented by the maximum number of bits that the conversion value can take. For example: if ADC has 10-bit resolution, the maximum value that can be written with 10 bits is 1024 [decimal]. This means that the measured voltage range, for example from 0-3.3V, can be divided into 1024 discrete steps of about 3.22mV [$3.3V / 1024 = 0.00322V$], so the smallest step of this conversion would be 3.22mV, and it represents the sensitivity of a particular ADC.

The Hexiwear Workstation board provides an interface in the form of one potentiometer, which acts as a voltage divider. One end of the potentiometer is connected to 3.3V, while the other end is connected to GND. This allows the selection of any voltage value in the range between GND and 3.3V. The potentiometer output is routed to a 2x4 header, which allows the selection of the pin to which the output voltage will be routed, by a jumper J1 [Figure 27].

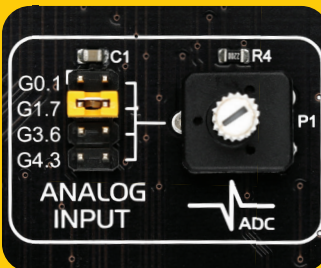

ADC inputs

In order to connect the output of the potentiometer P1 to G0.1, G1.7, G3.6, or G4.3 pins, J1 jumper should be placed in the desired position. By moving the potentiometer knob, the output voltage of the potentiometer can be selected in the range from GND to 3.3V

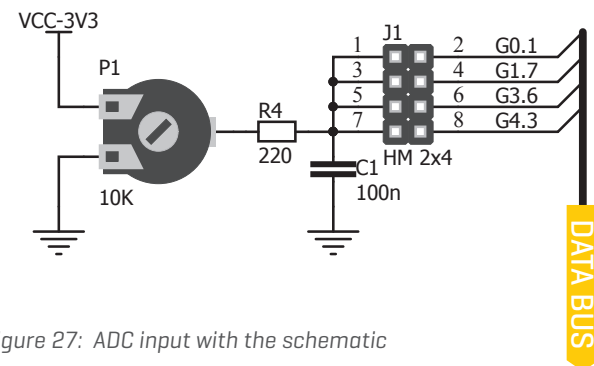

Figure 27: ADC input with the schematic

Piezo Buzzer

Piezoelectricity is the electrical charge which accumulates in certain solid materials, in response to mechanical pressure. Also, applying an electrical potential to the piezoelectric material, causes it to physically deform. One of the most widely used applications of the piezo electricity, is the production of sound generators, called piezo buzzers. Piezo buzzer is an electric component that comes in different shapes and sizes, which can be used to produce sound. Hexiwear Workstation comes with a piezo buzzer which can be connected to G2.5 or G4.0 pins. Connection is established using SW4.8 or SW5.8 DIP switch [Figure 28]. Buzzer is driven by the transistor Q1 [Figure 29]. Hexiwear can create sound by generating a PWM [Pulse Width Modulated] signal – a pulse train, sequence of pulses with the variable width [duty-cycle]. Frequency of the square signal determines the pitch of the generated sound, and duty cycle of the signal can be used to increase or decrease the volume in the range from 0% to 100% of the duty cycle. You can generate PWM signal by using the hardware capture and compare module, which is usually available in most microcontrollers, or by writing a custom software which emulates the desired signal waveform.

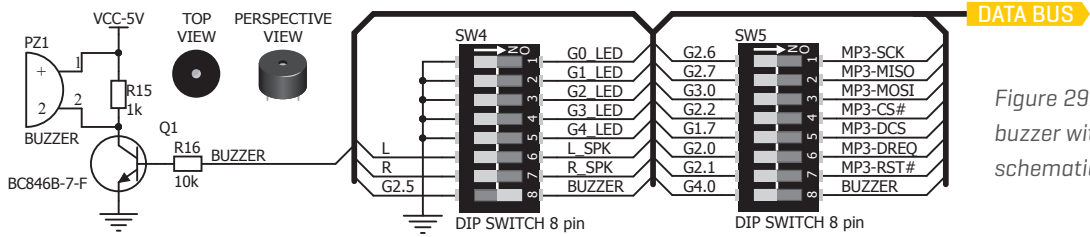

Figure 29: Piezo buzzer with the schematic

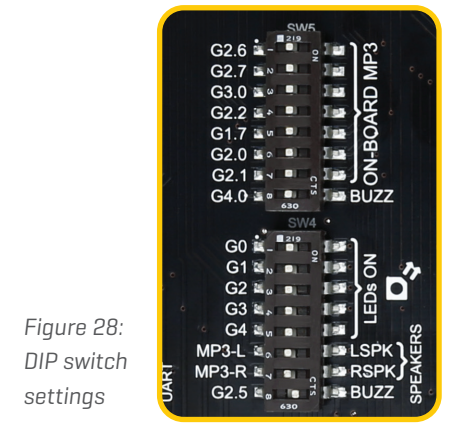
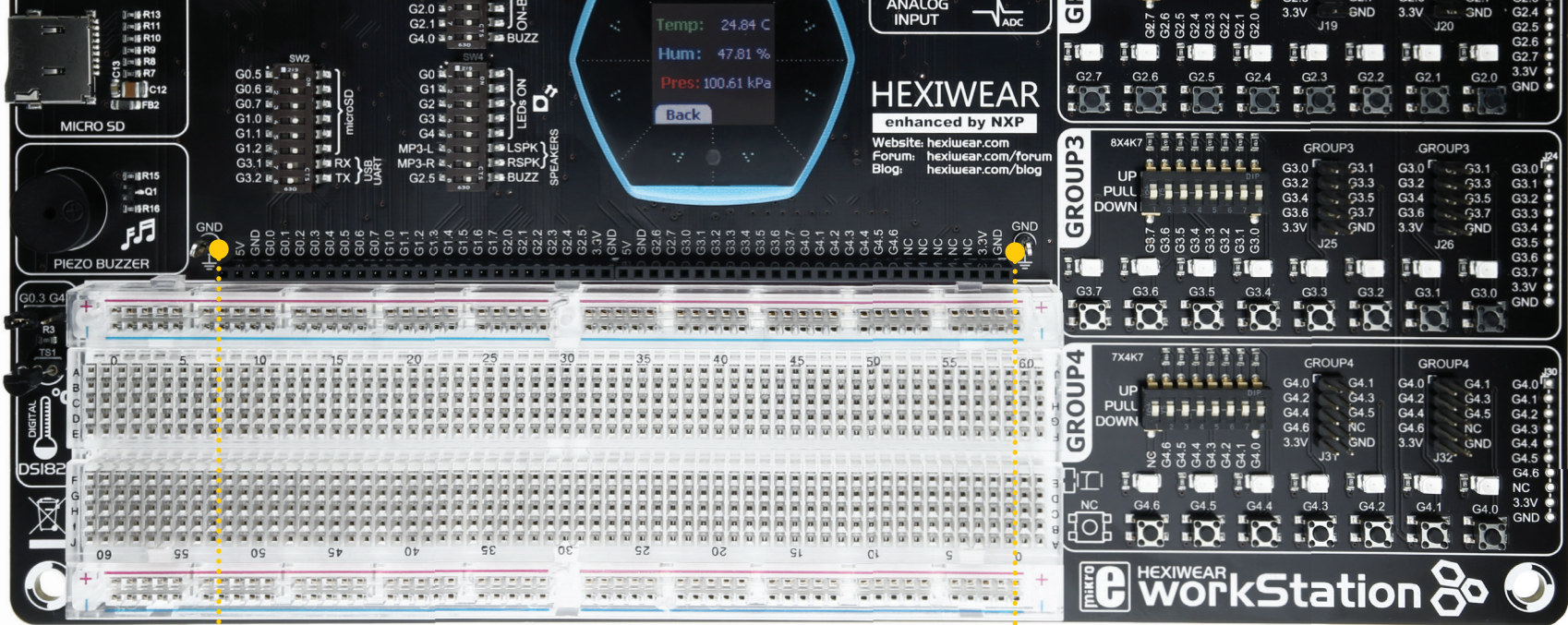

Figure 28: DIP switch settings

How to make it sing?

The Buzzer reproduces sound when the PWM signal is provided from Hexiwear. The pitch of the sound is determined by the frequency, and the amplitude is determined by the duty cycle of the applied PWM signal.





Additional GNDs

Hexiwear Workstation board contains two GND pins located in different sections of the board, which allow to easily connect oscilloscope GND reference probe or multimeter GND probe when monitoring signals on various pins, or signals on the peripheral modules.

1

GND pin is located on the left side of the proto-board area, next to the 1x52 female header



2

GND pin is located on the right side of the proto-board area, next to the 1x52 female header



Breadboard area

Hexiwear Workstation board contains breadboard area as well as additional 1x52 female header, side by side. The header contains all the available Hexiwear pins, along with the necessary 3.3V and 5V power supply outputs. This breadboard area is an ideal solution for rapid prototyping: the components such as resistors, diodes, various ICs, and other electrical components, can be directly plugged into the matrix of slots and connected to Hexiwear pins with the wire jumpers. The breadboard itself consists of a number of rows of female pins spaced 2.54 millimetres (0.1 inch) apart, with two power rails (positive and GND) on the each edge of the board. This allows a single pin to have more than one connection, allowing it to form an electrical circuit. The breadboard schematic can be viewed on the Figure 30.

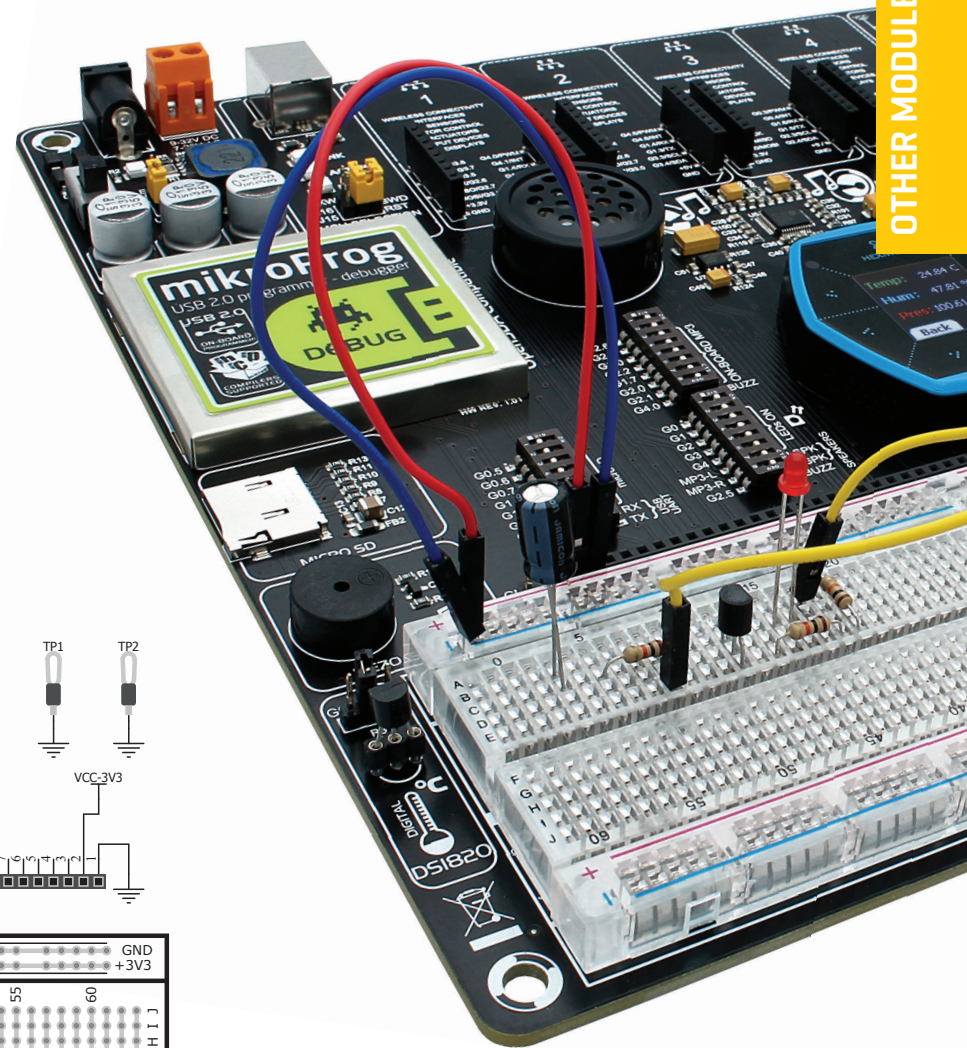
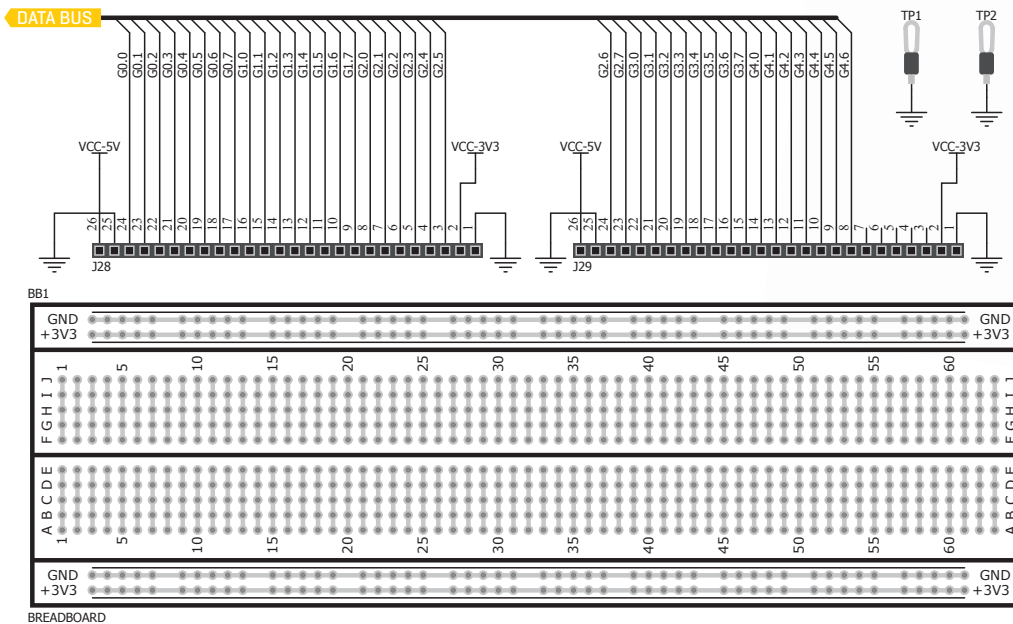

Figure 30: Breadboard with the schematic



What's Next?

You have now completed the journey through each and every feature of the Hexiwear Workstation. You have become familiar with its modules, organization, and the programmer/debugger. Now you are ready to start using your new board. We suggest several steps which are probably the best way to begin. We invite you to join thousands of users of MikroElektronika development tools. You will find useful projects and tutorials and get help from a large user community. Welcome!

1 COMPILERS

MikroElektronika offers top of the class line of compilers for full experience with the Hexiwear Workstation board. Easy programming, clean interface, powerful debugging, great support - our compilers come in three different flavors: mikroC PRO for ARM, mikroBASIC PRO for ARM and mikroPASCAL PRO for ARM, offering a complete rapid embedded development solution for these 3 major programming languages. Finally, having the OpenSDA compatible programmer opens a whole world of other possibilities for using the Hexiwear Workstation board. www.mikroe.com/hexiwear-workstation

2 PROJECTS

Once you have chosen your compiler, and since you already got the board, you are ready to start writing your first projects. We have equipped our compilers with dozens of examples that demonstrate the use of each and every feature of the Hexiwear workstation board. This makes an excellent starting point for future custom projects. Just load the example, read well commented code, and see how it works on hardware.

3 COMMUNITY

If you want to find answers to your questions on many interesting topics we invite you to visit our forum at <https://forum.mikroe.com> and browse through a vast number of posts. You are likely to find just the right information you were looking for. On the other hand, if you want to download free projects and libraries, or share your own code, please visit the Libstock website. With user profiles, you can get to know other programmers, and subscribe to receive notifications on their code. <https://libstock.mikroe.com>

4 SUPPORT

MikroElektronika offers Free Tech Support to the end of product lifetime, so if something goes wrong, we are ready and willing to help. We all know how important it is that we can rely on someone in moments when we are stuck with our projects, facing a deadline, or when we just want to ask a simple, basic question, that's pulling us back for a while. We do understand how important this is to people and therefore our Support Department is one of the pillars upon which our company is based.

<https://helpdesk.mikroe.com>

DISCLAIMER

All the products owned by MikroElektronika are protected by copyright law and international copyright treaty. Therefore, this manual is to be treated as any other copyright material. No part of this manual, including product and software described herein, must be reproduced, stored in a retrieval system, translated or transmitted in any form or by any means, without the prior written permission of MikroElektronika. The manual PDF edition can be printed for private or local use, but not for distribution. Any modification of this manual is prohibited.

MikroElektronika provides this manual 'as is' without warranty of any kind, either expressed or implied, including, but not limited to, the implied warranties or conditions of merchantability or fitness for a particular purpose.

MikroElektronika shall assume no responsibility or liability for any errors, omissions and inaccuracies that may appear in this manual. In no event shall MikroElektronika, its directors, officers, employees or distributors be liable for any indirect, specific, incidental or consequential damages [including damages for loss of business profits and business information, business interruption or any other pecuniary loss] arising out of the use of this manual or product, even if MikroElektronika has been advised of the possibility of such damages. MikroElektronika reserves the right to change information contained in this manual at any time without prior notice, if necessary.

HIGH RISK ACTIVITIES

The products of MikroElektronika are not fault – tolerant nor designed, manufactured or intended for use or resale as on – line control equipment in hazardous environments requiring fail – safe performance, such as in the operation of nuclear facilities, aircraft navigation or communication systems, air traffic control, direct life support machines or weapons systems in which the failure of Software could lead directly to death, personal injury or severe physical or environmental damage ['High Risk Activities']. MikroElektronika and its suppliers specifically disclaim any expressed or implied warranty of fitness for High Risk Activities.

TRADEMARKS

The MikroElektronika name and logo, the MikroElektronika logo, mikroC, mikroBasic, mikroPascal, mikroProg, mikromedia, EasyPIC, workStation, Click boards™ and mikroBUS™ are trademarks of MikroElektronika. All other trademarks mentioned herein are property of their respective companies.

All other product and corporate names appearing in this manual may or may not be registered trademarks or copyrights of their respective companies, and are only used for identification or explanation and to the owners' benefit, with no intent to infringe.

Copyright © MikroElektronika, 2018, All Rights Reserved.