

Features

- This device is qualified for automotive application
- Surface-mounting TO-252 power package in tape and reel
- Complementary to the PNP type MJD32C

Application

- General purpose linear and switching equipment

Description

The device is manufactured in planar technology with “base island” layout. The resulting transistor shows exceptional high gain performance coupled with very low saturation voltage.

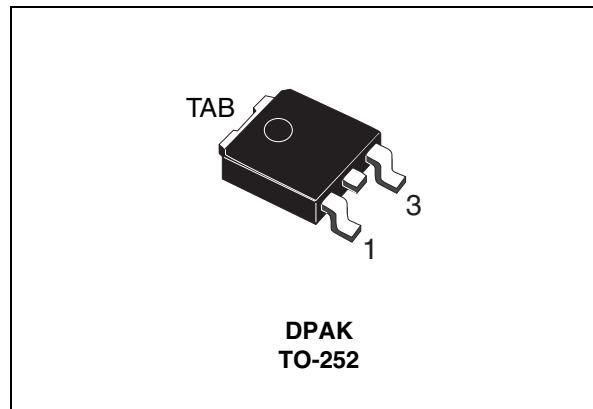

Figure 1. Internal schematic diagram

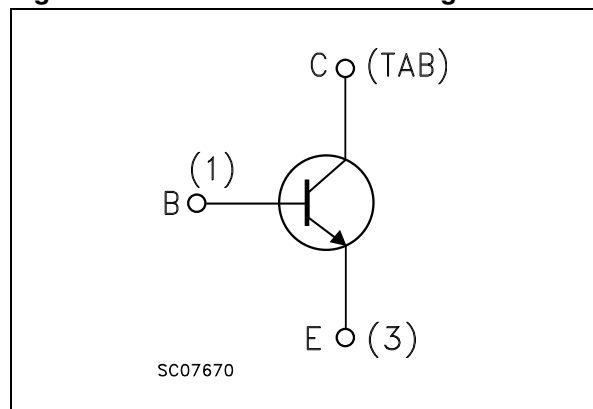

Table 1. Device summary

Order code	Marking	Package	Packaging
MJD31CT4-A	MJD31C	DPAK	Tape and reel

1 Electrical ratings

Table 2. Absolute maximum ratings

Symbol	Parameter	Value	Unit
V_{CBO}	Collector-base voltage ($I_E = 0$)	100	V
V_{CEO}	Collector-emitter voltage ($I_B = 0$)	100	V
V_{EBO}	Emitter-base voltage ($I_C = 0$)	5	V
I_C	Collector current	3	A
I_{CM}	Collector peak current	5	A
I_B	Base current	1	A
P_{TOT}	Total dissipation at $T_C = 25\text{ °C}$	15	W
T_{STG}	Storage temperature	-65 to 150	°C
T_J	Max. operating junction temperature	150	°C

Table 3. Thermal data

Symbol	Parameter	Value	Unit
R_{thJC}	Thermal resistance junction-case max	8.3	°C/W
$R_{thJPCB}^{(1)}$	Thermal resistance junction-pcb max	50	°C/W

1. When mounted on FR-4 board of 1 inch², 2 oz Cu.

2 Electrical characteristics

$T_{case} = 25\text{ }^{\circ}\text{C}$ unless otherwise specified.

Table 4. Electrical characteristics

Symbol	Parameter	Test conditions	Min.	Typ.	Max.	Unit
I_{CES}	Collector cut-off current ($V_{BE} = 0$)	$V_{CE} = 100\text{ V}$		-	20	μA
I_{CEO}	Collector cut-off current ($I_B = 0$)	$V_{CB} = 60\text{ V}$		-	50	μA
I_{EBO}	Emitter cut-off current ($I_C = 0$)	$V_{EB} = 5\text{ V}$		-	0.1	mA
$V_{CE(sus)}^{(1)}$	Collector-emitter sustaining voltage ($I_B = 0$)	$I_C = 30\text{ mA}$	100	-		V
$V_{CE(sat)}^{(1)}$	Collector-emitter saturation voltage	$I_C = 3\text{ A}$ $I_B = 375\text{ mA}$		-	1.2	V
$V_{BE(on)}^{(1)}$	Base-emitter on voltage	$I_C = 3\text{ A}$ $V_{CE} = 4\text{ V}$		-	1.8	V
h_{FE}	DC current gain	$I_C = 1\text{ A}$ $V_{CE} = 4\text{ V}$ $I_C = 3\text{ A}$ $V_{CE} = 4\text{ V}$	25 10	-	50	

1. Pulse test: pulse duration $\leq 300\text{ }\mu\text{s}$, duty cycle $\leq 2\%$

2.1 Electrical characteristic (curves)

Figure 2. Safe operating area

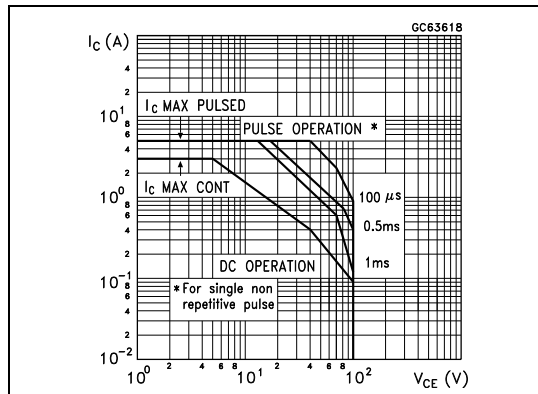

Figure 3. Derating curve

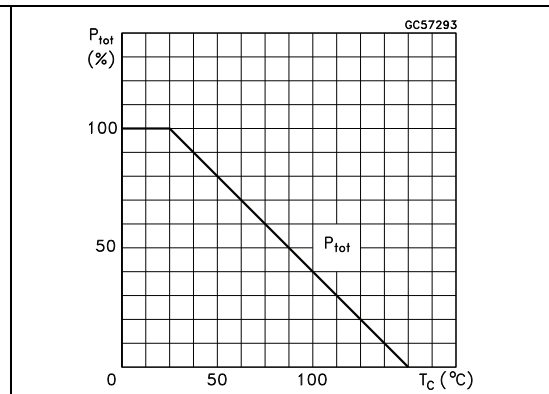

Figure 4. DC current gain ($V_{CE} = 2\text{ V}$)

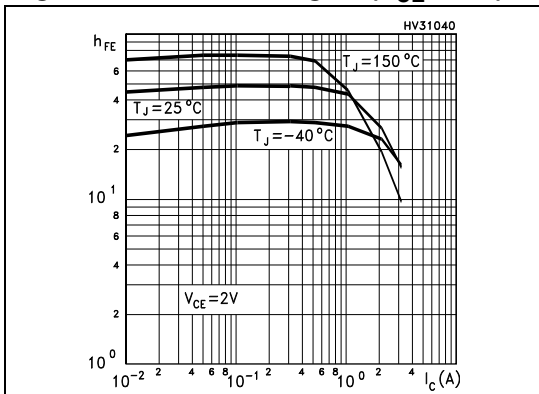

Figure 5. DC current gain ($V_{CE} = 4\text{ V}$)

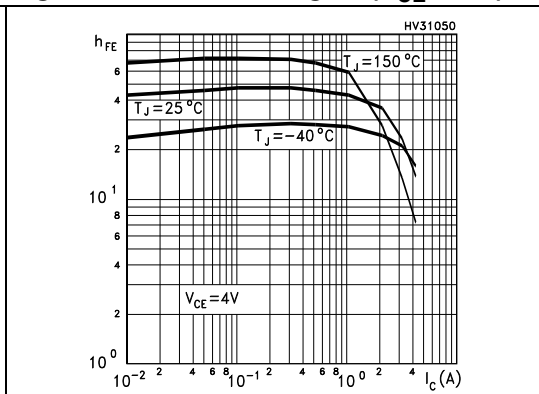

Figure 6. Collector-emitter saturation voltage

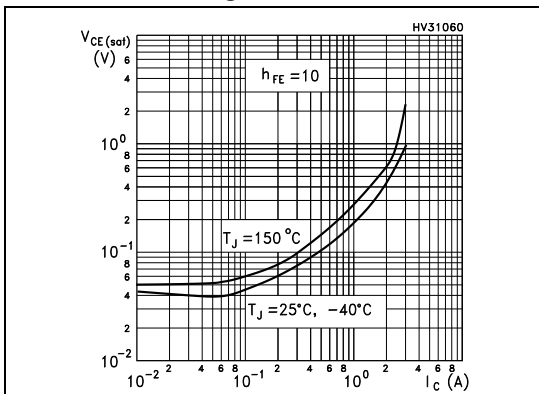

Figure 7. Base-emitter saturation voltage

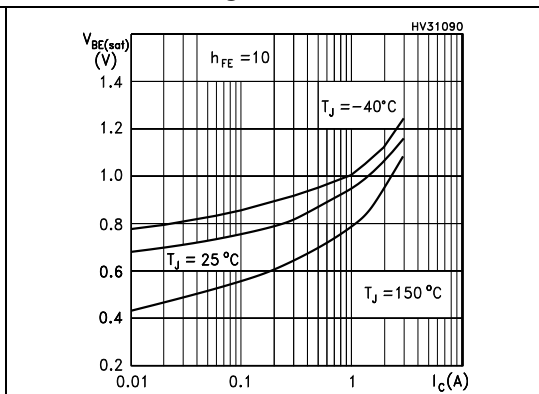

Figure 8. Base-emitter on voltage

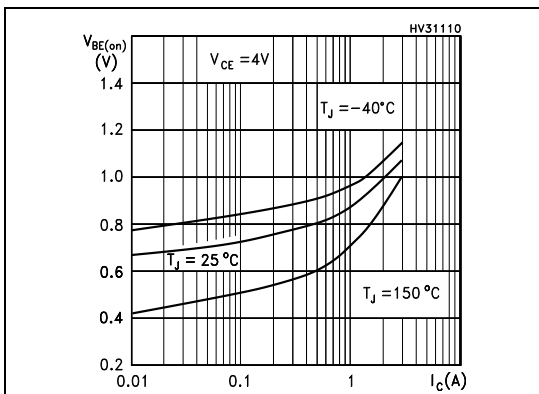

Figure 9. Resistive load switching time (on)

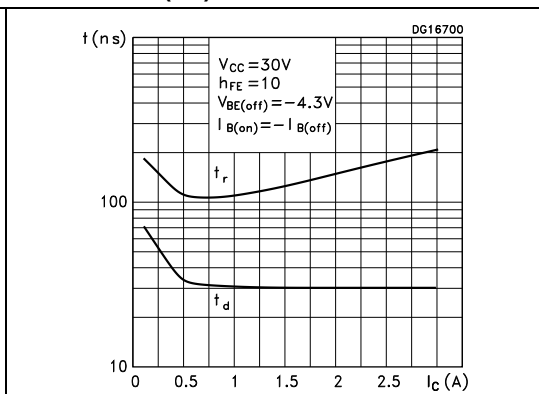
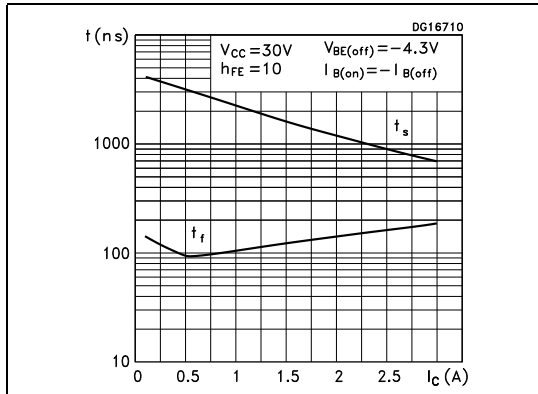
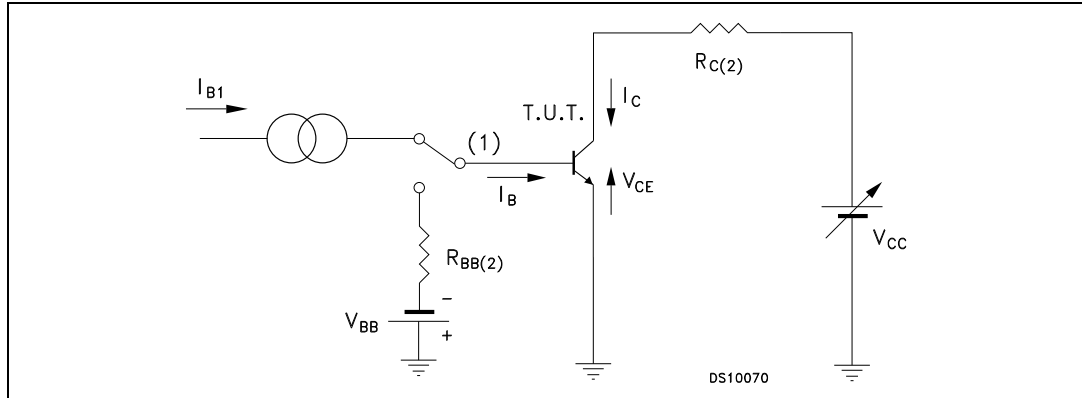

Figure 10. Resistive load switching time (off)



2.2 Test circuits

Figure 11. Resistive load switching test circuit



1. Fast electronic switch
2. Non-inductive resistor

Figure 12. Inductive load switching test circuit

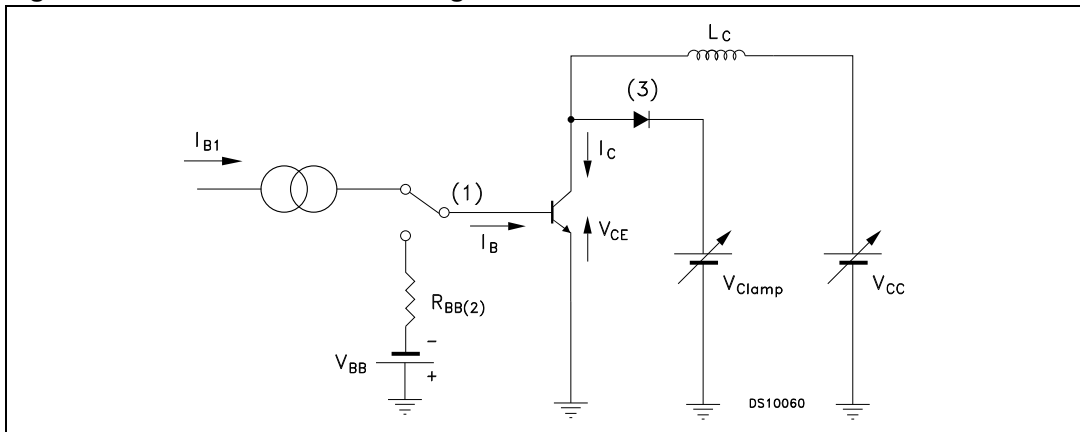

1. Fast electronic switch
2. Non-inductive resistor
3. Fast recovery rectifier

3 Package mechanical data

In order to meet environmental requirements, ST offers these devices in different grades of ECOPACK[®] packages, depending on their level of environmental compliance. ECOPACK[®] specifications, grade definitions and product status are available at: www.st.com. ECOPACK[®] is an ST trademark.

Table 5. DPAK (TO-252) mechanical data

Dim.	mm		
	Min.	Typ.	Max.
A	2.20		2.40
A1	0.90		1.10
A2	0.03		0.23
b	0.64		0.90
b4	5.20		5.40
c	0.45		0.60
c2	0.48		0.60
D	6.00		6.20
D1		5.10	
E	6.40		6.60
E1		4.70	
e		2.28	
e1	4.40		4.60
H	9.35		10.10
L	1		1.50
L1		2.80	
L2		0.80	
L4	0.60		1
R		0.20	
V2	0°		8°

Figure 13. DPAK (TO-252) drawing



Table 6. DPAK (TO-252) tape and reel mechanical data

Tape			Reel		
Dim.	mm		Dim.	mm	
	Min.	Max.		Min.	Max.
A0	6.8	7	A		330
B0	10.4	10.6	B	1.5	
B1		12.1	C	12.8	13.2
D	1.5	1.6	D	20.2	
D1	1.5		G	16.4	18.4
E	1.65	1.85	N	50	
F	7.4	7.6	T		22.4
K0	2.55	2.75			
P0	3.9	4.1	Base qty.		2500
P1	7.9	8.1	Bulk qty.		2500
P2	1.9	2.1			
R	40				
T	0.25	0.35			
W	15.7	16.3			

Figure 14. DPAK footprint^(a)

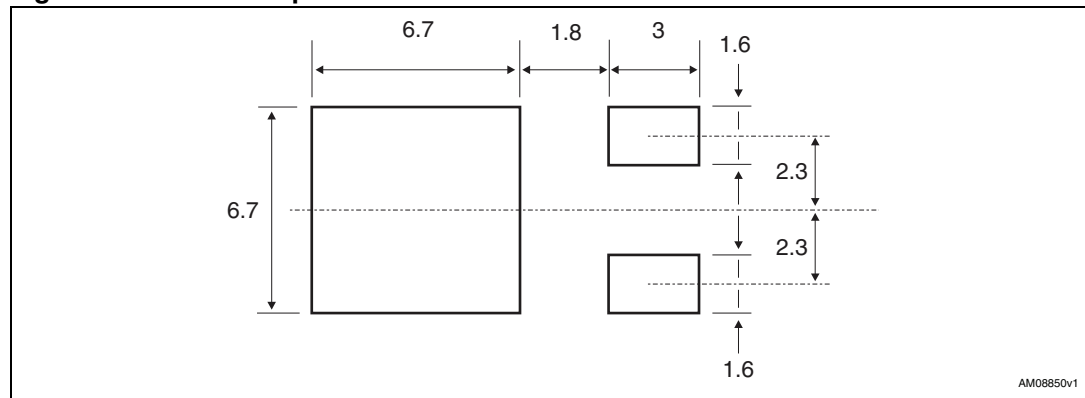

a. All dimensions are in millimeters

Figure 15. Tape for DPAK (TO-252)

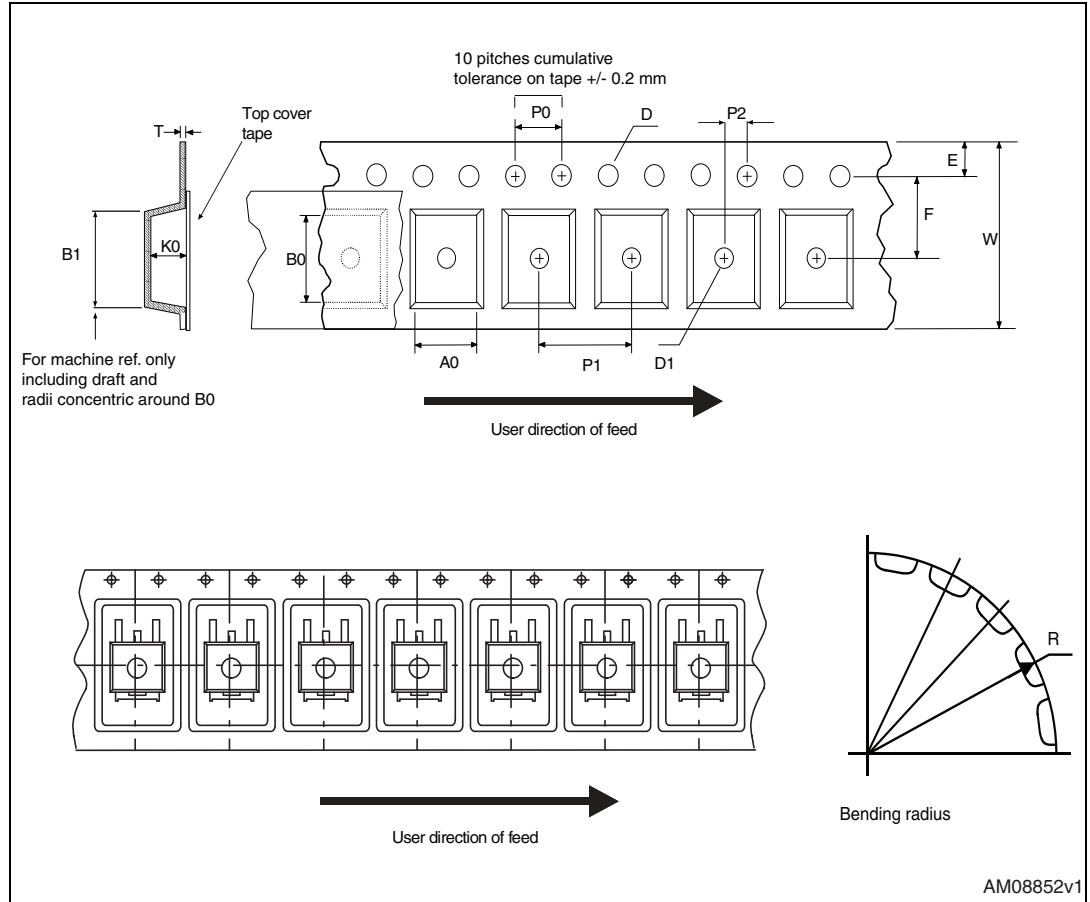
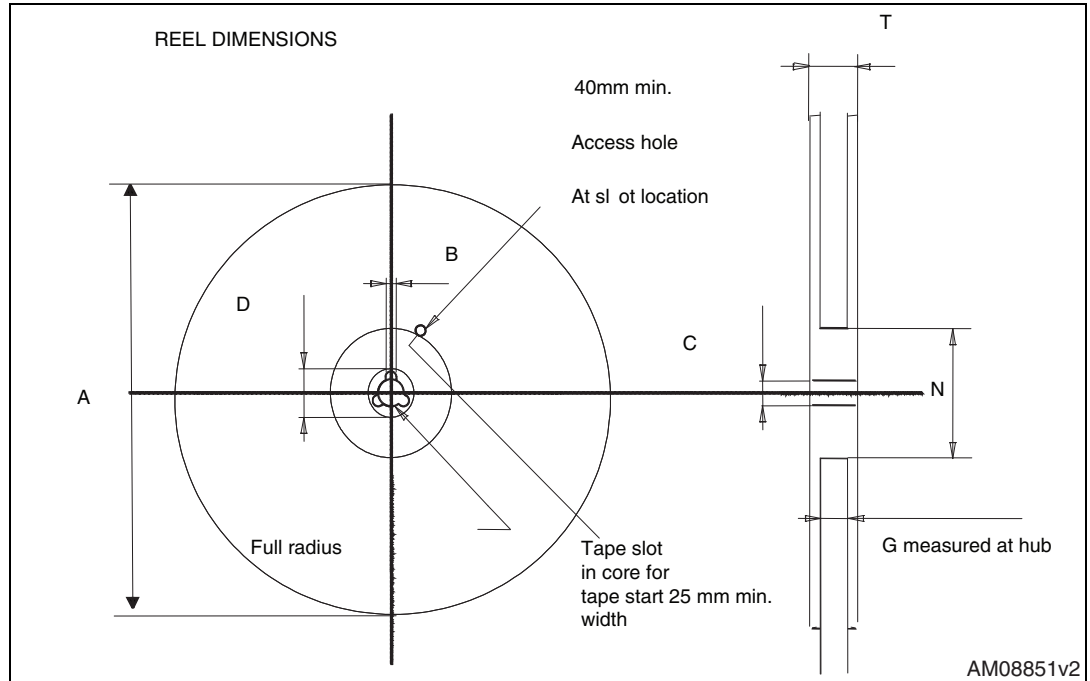

Figure 16. Reel for DPAK (TO-252)



4 Revision history

Table 7. Document revision history

Date	Revision	Changes
24-Apr-2007	1	Initial release.
09-Nov-2009	2	Updated package mechanical data.
14-Jan-2010	3	Modified Table 3 on page 2 .
19-Jun-2012	4	Modified: mechanical data