

## NPN power transistor

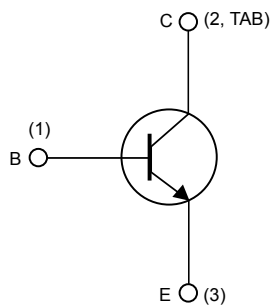
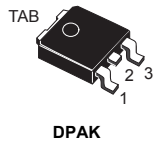

### Features

- Surface-mounting DPAK (TO-252) power package in tape and reel
- Electrically similar to TIP47

### Application

- Switch mode power supplies
- Audio amplifiers
- General purpose switching and amplifier

### Description

The device is manufactured using medium voltage epitaxial planar technology, resulting in a rugged high-performance cost-effective transistor.

#### Product status link

[MJD47T4](#)

#### Product summary

<b>Order code</b>	MJD47T4
<b>Marking</b>	MJD47
<b>Package</b>	DPAK
<b>Packing</b>	Tape and reel

## 1 Electrical ratings

**Table 1. Absolute maximum ratings**

Symbol	Parameter	Value	Unit
$V_{CBO}$	Collector-base voltage ( $I_E = 0$ V)	350	V
$V_{CEO}$	Collector-emitter voltage ( $I_B = 0$ A)	250	V
$V_{EBO}$	Collector-base voltage ( $I_C = 0$ A)	5	V
$I_C$	Collector current	1	A
$I_{CM}$	Collector peak current ( $t_p < 5$ ms)	2	A
$I_B$	Base current	0.6	A
$I_{BM}$	Base peak current ( $t_p < 5$ ms)	1.2	A
$P_{TOT}$	Total power dissipation at $T_C = 25$ °C	15	W
$T_{stg}$	Storage temperature range	-65 to 150	°C
$T_J$	Maximum operating junction temperature	150	°C

**Table 2. Thermal data**

Symbol	Parameter	Value	Unit
$R_{thJC}$	Thermal resistance, junction-to-case	8.33	°C/W
$R_{thJA}$	Thermal resistance, junction-to-ambient	100	°C/W

## 2 Electrical characteristics

$T_C = 25^\circ\text{C}$  unless otherwise specified.

**Table 3. Electrical characteristics**

Symbol	Parameter	Test conditions	Min.	Typ.	Max.	Unit
$I_{CES}$	Collector cut-off current	$V_{CE} = 350\text{ V}, V_{BE} = 0\text{ V}$		-	0.1	mA
$I_{CEO}$	Collector cut-off current	$V_{CE} = 150\text{ V}, I_B = 0\text{ A}$		-	0.1	mA
$I_{EBO}$	Emitter cut-off current	$V_{EB} = 5\text{ V}, I_C = 0\text{ A}$		-	1	mA
$V_{CEO(sus)}^{(1)}$	Collector-emitter sustaining voltage	$I_C = 30\text{ mA}, I_B = 0\text{ A}$	250	-		V
$V_{CE(sat)}^{(1)}$	Collector-emitter saturation voltage	$I_C = 1\text{ A}, I_B = 0.2\text{ A}$		-	1	V
$V_{BE(on)}^{(1)}$	Base-emitter on-voltage	$I_C = 1\text{ A}, V_{CE} = 10\text{ V}$		-	1.5	V
$h_{FE}^{(1)}$	DC current gain	$I_C = 0.3\text{ A}, V_{CE} = 10\text{ V}$	30	-	150	
		$I_C = 1\text{ A}, V_{CE} = 10\text{ V}$	10	-		
$f_T$	Transition frequency	$I_C = 0.2\text{ A}, V_{CE} = 10\text{ V}, f = 2\text{ MHz}$	10	-		MHz
$h_{fe}$	Small signal current gain	$I_C = 0.2\text{ A}, V_{CE} = 10\text{ V}, f = 1\text{ kHz}$	25	-		

1. Pulsed: Pulse duration = 300  $\mu\text{s}$ , duty cycle 1.5%.

## 2.1 Electrical characteristics (curves)

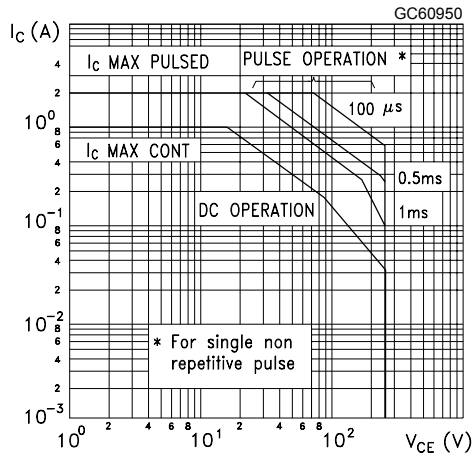
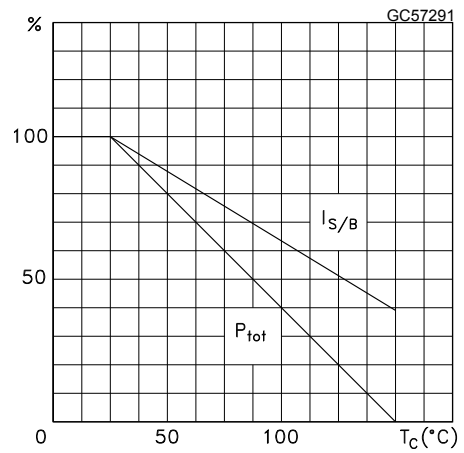
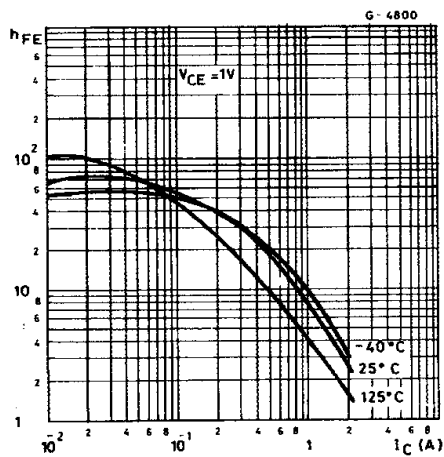
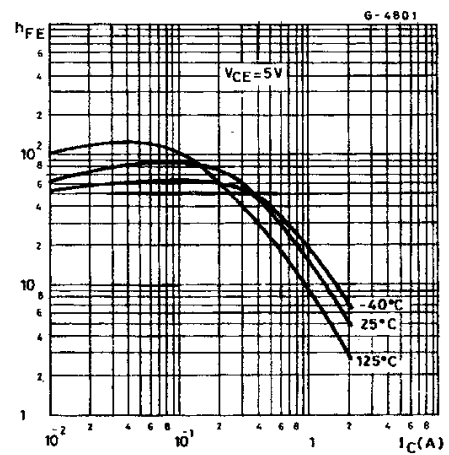
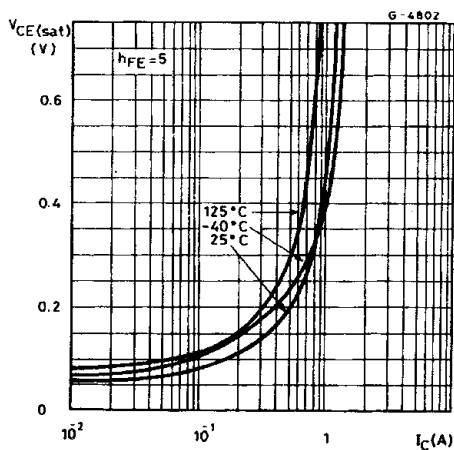
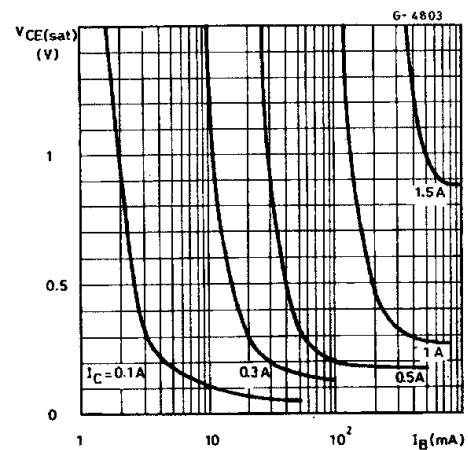
**Figure 1. Safe operating area**

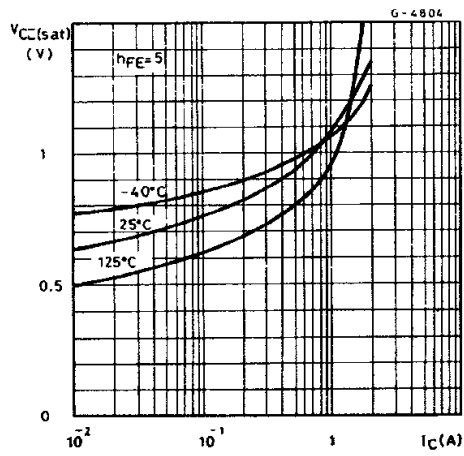
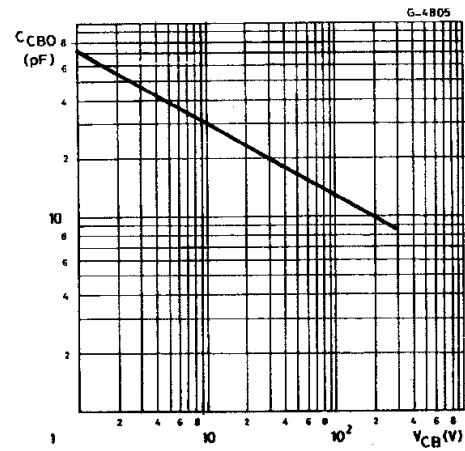
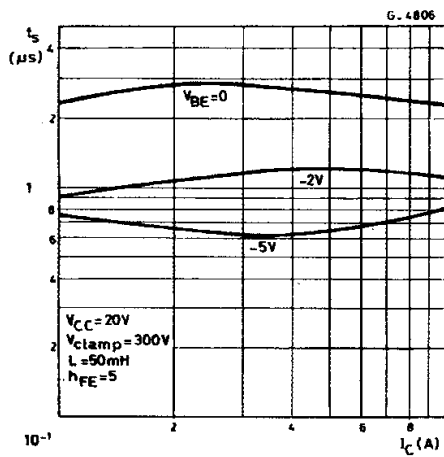
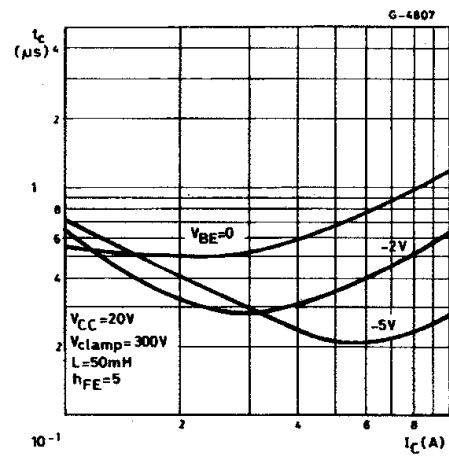
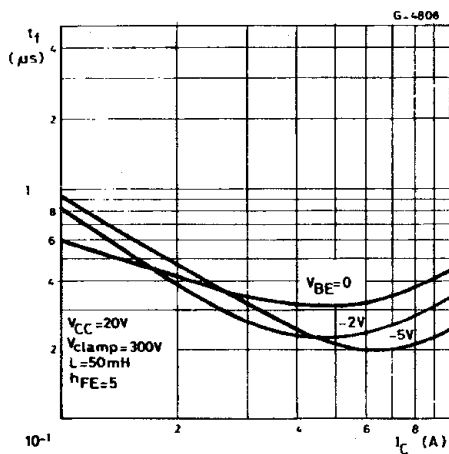
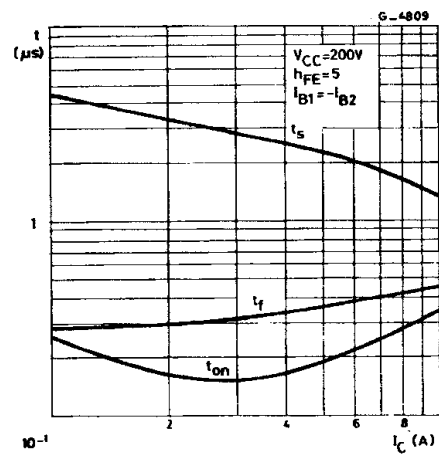
**Figure 2. Derating curves**

**Figure 3. DC current gain ( $V_{CE} = 1V$ )**

**Figure 4. DC current gain ( $V_{CE} = 5V$ )**

**Figure 5. Collector-emitter saturation voltage vs  $I_C$** 

**Figure 6. Collector-emitter saturation voltage vs  $I_B$** 

**Figure 7. Base-emitter saturation voltage**

**Figure 8. Collector-base capacitance**

**Figure 9. Storage time**

**Figure 10. Crossing time**

**Figure 11. Fall time**

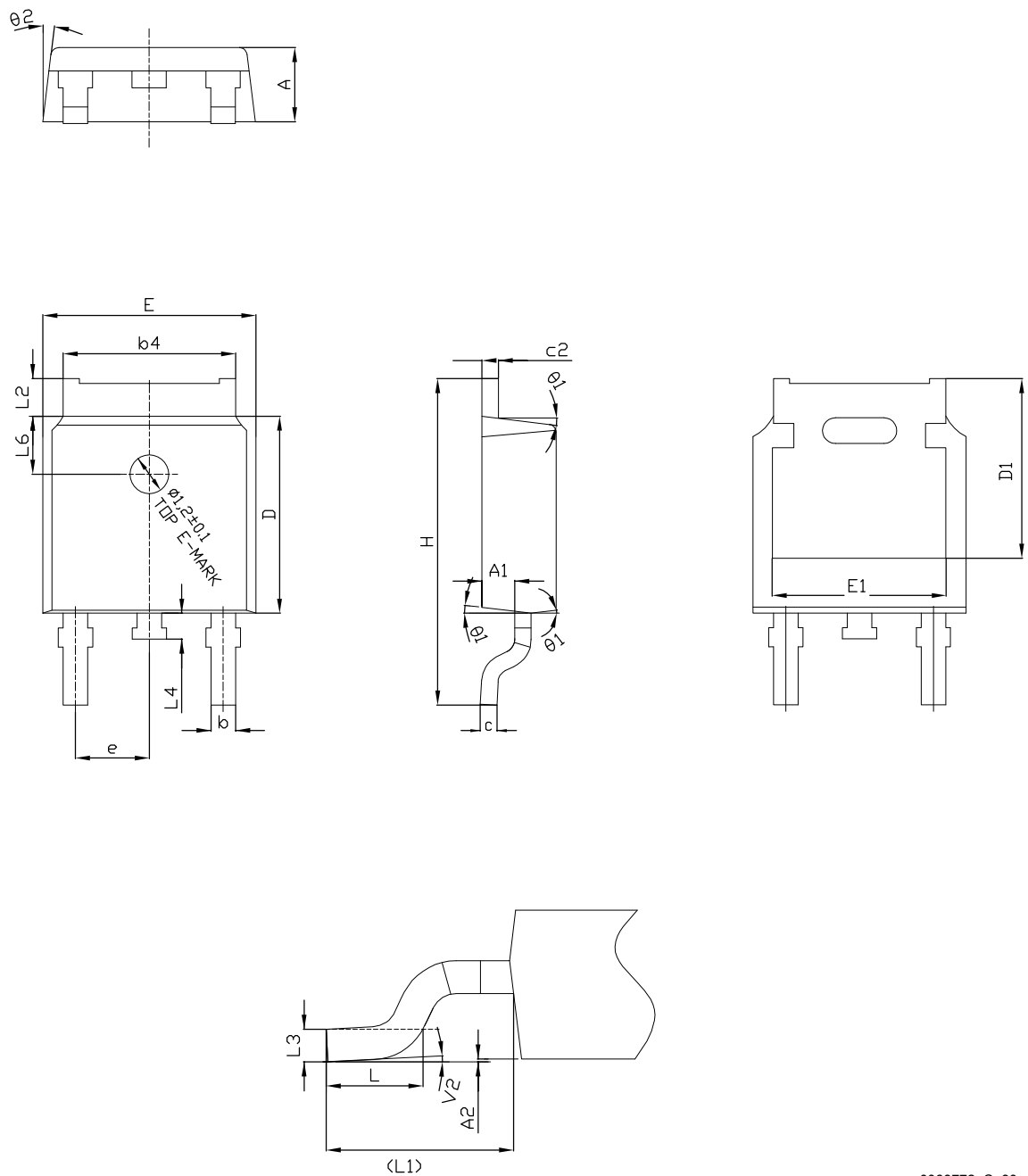
**Figure 12. Resistive load switching times**

### 3 Package information

In order to meet environmental requirements, ST offers these devices in different grades of **ECOPACK** packages, depending on their level of environmental compliance. ECOPACK specifications, grade definitions and product status are available at: [www.st.com](http://www.st.com). ECOPACK is an ST trademark.

#### 3.1 DPAK (TO-252) type C package information

Figure 13. DPAK (TO-252) type C package outline



0068772\_C\_30

**Table 4. DPAK (TO-252) type C mechanical data**

Dim.	mm		
	Min.	Typ.	Max.
A	2.20	2.30	2.38
A1	0.90	1.01	1.10
A2	0.00		0.10
b	0.72		0.85
b4	5.13	5.33	5.46
c	0.47		0.60
c2	0.47		0.60
D	6.00	6.10	6.20
D1	5.25		
E	6.50	6.60	6.70
E1	4.70		
e	2.186	2.286	2.386
H	9.80	10.10	10.40
L	1.40	1.50	1.70
L1	2.90 REF		
L2	0.90		1.25
L3	0.51 BSC		
L4	0.60	0.80	1.00
L6	1.80 BSC		
θ1	5°	7°	9°
θ2	5°	7°	9°
V2	0°		8°

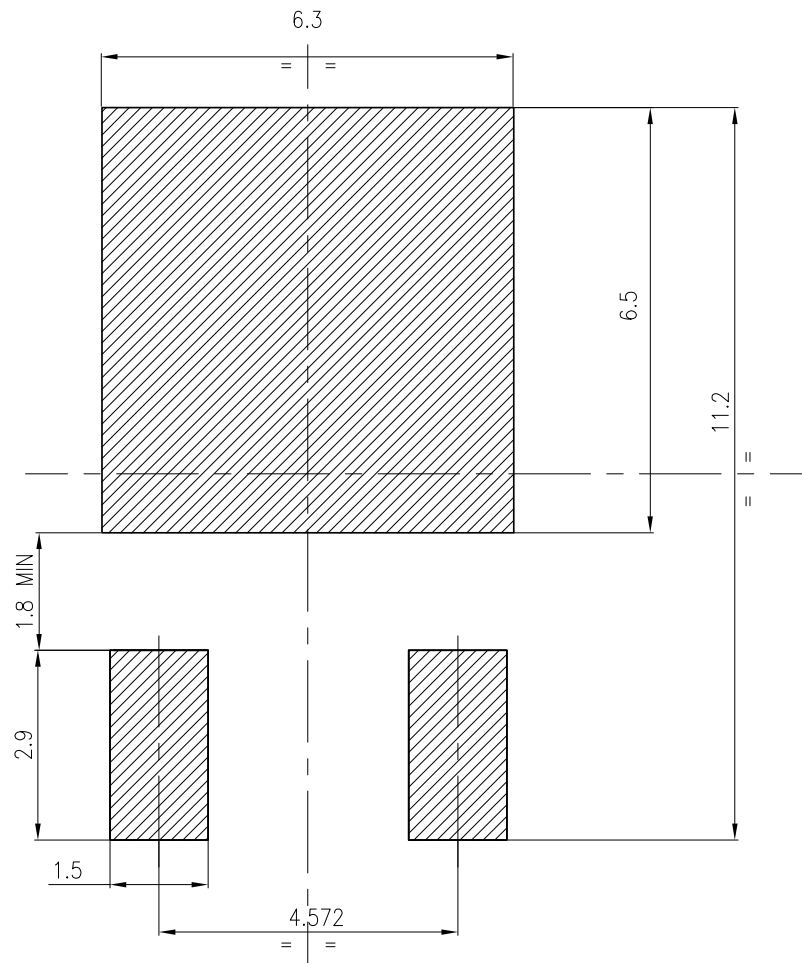
**Figure 14. DPAK (TO-252) recommended footprint (dimensions are in mm)**

FP\_0068772\_30



### 3.2 DPAK (TO-252) packing information

Figure 15. DPAK (TO-252) tape outline

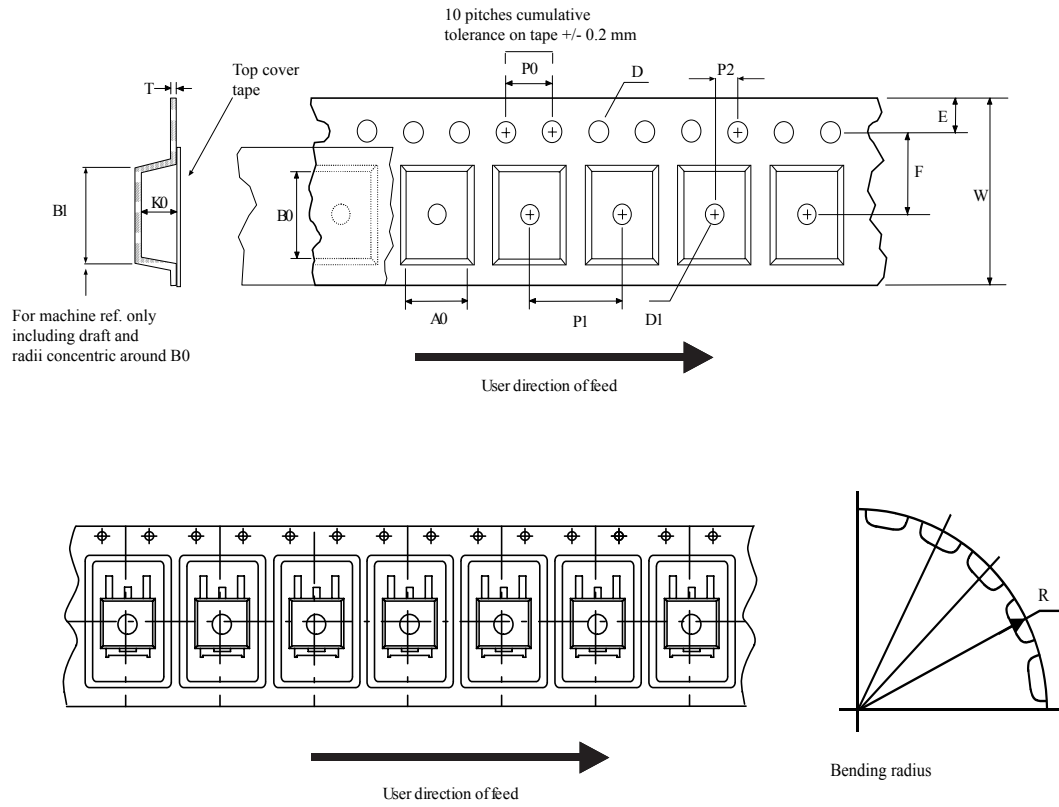

AM08852v1

Figure 16. DPAK (TO-252) reel outline

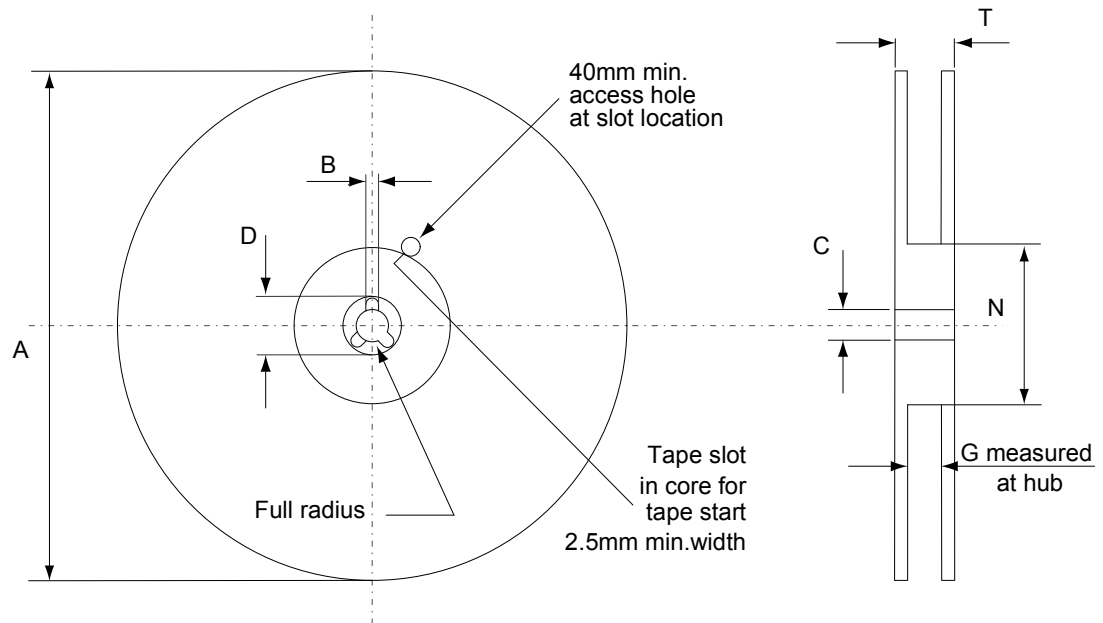

AM06038v1

Table 5. DPAK (TO-252) tape and reel mechanical data

Dim.	Tape		Dim.	Reel	
	mm			mm	
	Min.	Max.		Min.	Max.
A0	6.8	7	A		330
B0	10.4	10.6	B	1.5	
B1		12.1	C	12.8	13.2
D	1.5	1.6	D	20.2	
D1	1.5		G	16.4	18.4
E	1.65	1.85	N	50	
F	7.4	7.6	T		22.4
K0	2.55	2.75			
P0	3.9	4.1		Base qty.	2500
P1	7.9	8.1		Bulk qty.	2500
P2	1.9	2.1			
R	40				
T	0.25	0.35			
W	15.7	16.3			

## Revision history

**Table 6. Document revision history**

Date	Revision	Changes
17-Mar-2022	1	First release.