

## MLH Series

### All Metal Pressure Sensors



#### DESCRIPTION

MLH Series pressure sensors combine Application Specific Integrated Circuit (ASIC) technology with a media isolated, metal diaphragm design. This digitally compensated sensor offers value and performance, making it the ideal pressure sensing solution for demanding applications. Fully temperature compensated, calibrated and amplified, the MLH is available in 50 psi to 8,000 psi pressure ranges.

MLH sensors deliver  $\pm 0.25\%$  full scale accuracy Best Fit Straight Line (BFSL) and as low as 2% total error over a temperature range of  $-40\text{ }^{\circ}\text{C}$  to  $125\text{ }^{\circ}\text{C}$  [ $-40\text{ }^{\circ}\text{F}$  to  $257\text{ }^{\circ}\text{F}$ ]. Industry standard connectors and process ports are offered for enhanced reliability and user flexibility.

#### FEATURES

- All metal wetted parts for use in wide variety of fluid applications
- No internal elastomeric seals mean no o-ring compatibility issues
- Amplified outputs eliminate cost of external amplifiers
- Input reverse voltage protection guards against mis-wiring
- Less than 2 ms response time provides accurate, high speed measurement
- Rated IP65 or better for protection from harsh environments

The MLH has six standard output options:

- A. 0.5 Vdc to 4.5 Vdc ratiometric from 5 Vdc excitation
- B. 4 mA to 20 mA
- C. 1 Vdc to 6 Vdc regulated
- D. 0.25 Vdc to 10.25 Vdc regulated
- E. 0.5 Vdc to 4.5 Vdc regulated
- G. 1 Vdc to 5 Vdc regulated

#### POTENTIAL APPLICATIONS

- Compressors
- Refrigeration and HVAC/R
- General industrial
- General hydraulics
- Multiple transportation applications including braking and alternate fuels
- Medical

# MLH Series

**Table 1. Pressure Range Specifications<sup>1</sup> (At 25 °C [77 °F] and at rated excitation unless otherwise specified.)**

psi												
Pressure	50	100	150	200	250	300	500	1000	2000	3000	5000	8000
Proof pressure	150	300	450	600	750	900	1500	2000	4000	6000	7500	12000
Burst pressure	500	1000	1500	2000	2500	3000	5000	10000	20000	30000	30000	30000
bar												
Pressure	6	10	16	25	40	60	100	160	250	350	500	550
Proof pressure	18	30	48	75	80	120	200	320	500	700	750	825
Burst pressure	60	100	160	250	400	600	1000	1600	2068	2068	2068	2068

**Note:**

1. Comparable metric units follow same proof and burst specifications.

**Table 2. Physical and Environmental Specifications**

Parameter	Characteristic
Material in contact with media	port: stainless steel 304L; diaphragm: Haynes 214 alloy
Housing material	black plastic – Amodel AS-4133 HS – PPA
Weight	57.0 g [2.0 oz] (typical for Delphi Metri-Pack 150 and 1/8 NPT port)
Shock	100 g peak [11 ms]
Vibration	MIL-STD-810C, Figure 514.2-5, Curve AK, Table 514.2-V, Random Vibration Test [overall g rms = 20.7 min.]
Compensated and operating temperature range: 0.5 Vdc to 4.5 Vdc ratiometric output all regulated and 4 mA to 20 mA outputs	-40 °C to 125 °C [-40 °F to 257 °F] -40 °C to 125 °C [-40 °F to 257 °F] See Figures 2 and 3 for operating area details.
Storage temperature range	-40 °C to 125 °C [-40 °F to 257 °F]
Approvals	UL Component Recognition for USA and Canada: File No. E258956

**Table 3. Electrical Specifications (At 25 °C [77 °F] and at rated excitation unless otherwise specified.)**

Parameter	Ratiometric (A)	Current (B)	Regulated (C)	Regulated (D)	Regulated (E)	Regulated (G)
Zero output	0.5 Vdc	4 mA	1 Vdc	0.25 Vdc	0.5 Vdc	1 Vdc
Full scale span (FSS)	4 Vdc (0.5 Vdc to 4.5 Vdc)	16 mA (4 mA to 20 mA)	5 Vdc (1 Vdc to 6 Vdc)	10 Vdc (0.25 Vdc to 10.25 Vdc)	4 Vdc (0.5 Vdc to 4.5 Vdc)	4 Vdc (1 Vdc to 5 Vdc)
Excitation	5 Vdc (6 Vdc max.) <sup>1</sup>	9.5 Vdc to 30 Vdc <sup>2</sup>	8 Vdc to 30 Vdc <sup>2</sup>	14 Vdc to 30 Vdc <sup>2</sup>	7 Vdc to 30 Vdc <sup>2</sup>	8 Vdc to 30 Vdc <sup>2</sup>
Supply current	4 mA typ. (8 mA max.)	N/A	5 mA typ. (17 mA max.)	5 mA typ. (17 mA max.)	5 mA typ. (17 mA max.)	5 mA typ. (17 mA max.)
Source (nominal)	1 mA	N/A	1 mA	1 mA	1 mA	1 mA
Sink (nominal)	1 mA at zero output	N/A	1 mA at zero output	1 mA at zero output	1 mA at zero output	1 mA at zero output
Supply rejection ratio	90 dB	90 dB	90 dB	90 dB	90 dB	90 dB
Output impedance	25 Ω max.	N/A	25 Ω max.	25 Ω max.	25 Ω max.	25 Ω max.

**Notes:**

1. Maintains ratiometricity at 5 ±0.25 Vdc excitation. Product can tolerate 6 Vdc excitation without damage.
2. See Figures 2 and 3 for more information regarding maximum excitation voltage vs. operating temperature.

# All Metal Pressure Sensors

**Table 4. Performance Specifications (At 25 °C [77 °F] and at rated excitation unless otherwise specified.)**

Parameter	Characteristic
Response time	<2 ms
Accuracy <sup>1</sup> : ≥100 psi <100 psi	±0.25% FSS ±0.50% FSS
Total error band <sup>2</sup> : Gage: <300 psig ≥300 psig Seal gage: ≥300 psig Seal gage <u>without</u> L, M, P termination: 100 psig to 299 psig (-40 °C to 85 °C [-40 °F to 185 °F]) 100 psig to 299 psig (>85 °C to 125 °C [>185 °F to 257 °F]) ≥300 psig (-40 °C to 125 °C [-40 °F to 257 °F]) Seal gage <u>with</u> L, M, P termination: 100 psig to 299 psig (-40 °C to 65 °C [-40 °F to 149 °F]) 100 psig to 299 psig (>65 °C to 125 °C [>149 °F to 257 °F]) ≥300 psig (-40 °C to 65 °C [-40 °F to 149 °F]) ≥300 psig (>65 °C to 125 °C [>149 °F to 257 °F])	±3% FSS ±2% FSS ±2% FSS ±3% FSS ±10% FSS ±2% FSS ±10% FSS ±15% FSS ±5% FSS ±15% FSS

**Notes:**

1. Includes pressure non-linearity (BFSL), pressure hysteresis and non-repeatability. Thermal errors are not included.
2. Includes zero error, span error, thermal effect on zero, thermal effect on span, thermal hysteresis, pressure-non-linearity, pressure hysteresis and non-repeatability.

**Figure 2. Operating and Temperature Compensated Area for All Regulated Output Options**

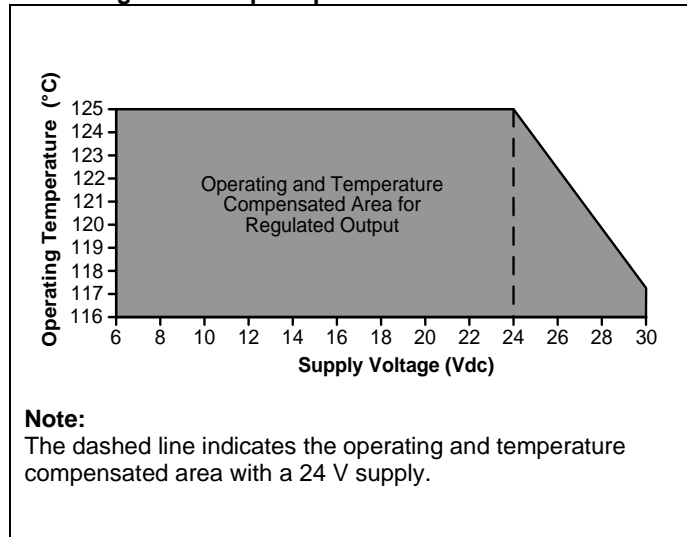

**Figure 3. Operating and Temperature Compensated Area for 4 mA to 20 mA Output**

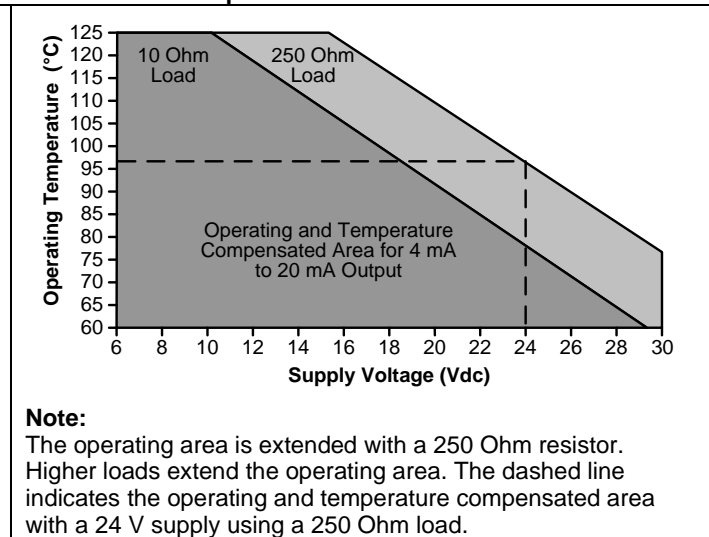

**Figure 4. Mounting Dimensions (For reference only. mm/(in.))**

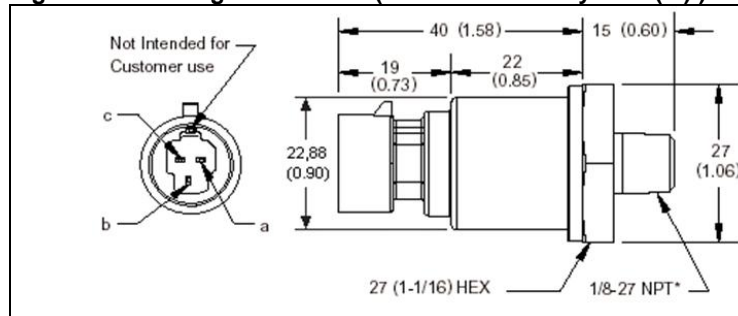

**Pin and Wire Codes (Option B – Packard)**

Pin	Voltage	Current
a	+ excitation	+ excitation
b	output	- excitation
c	common	no connection

A variety of pressure ports and electrical termination connection options are available. Refer to the "How to Order" on previous page for possible combinations. Contact your Honeywell representative for details.