

MM5130

Evaluation Kit Instructions

You hold in your hands an evaluation board package for the MM5130 Switch. The board is intended for evaluation of RF performance such as insertion loss, return loss and isolation over frequency.

INCLUDED IN YOUR EVALUATION KIT:

- MM5130 Evaluation Board, packaged in protective ESD bag.
- Mini-USB cable, for controlling the board.
- Control Software on USB memory stick.
- MM5130 Datasheet
- Quick Start Guide (this document)

**MM5130 EVK WITH
ATTACHED DRIVER BOARD**

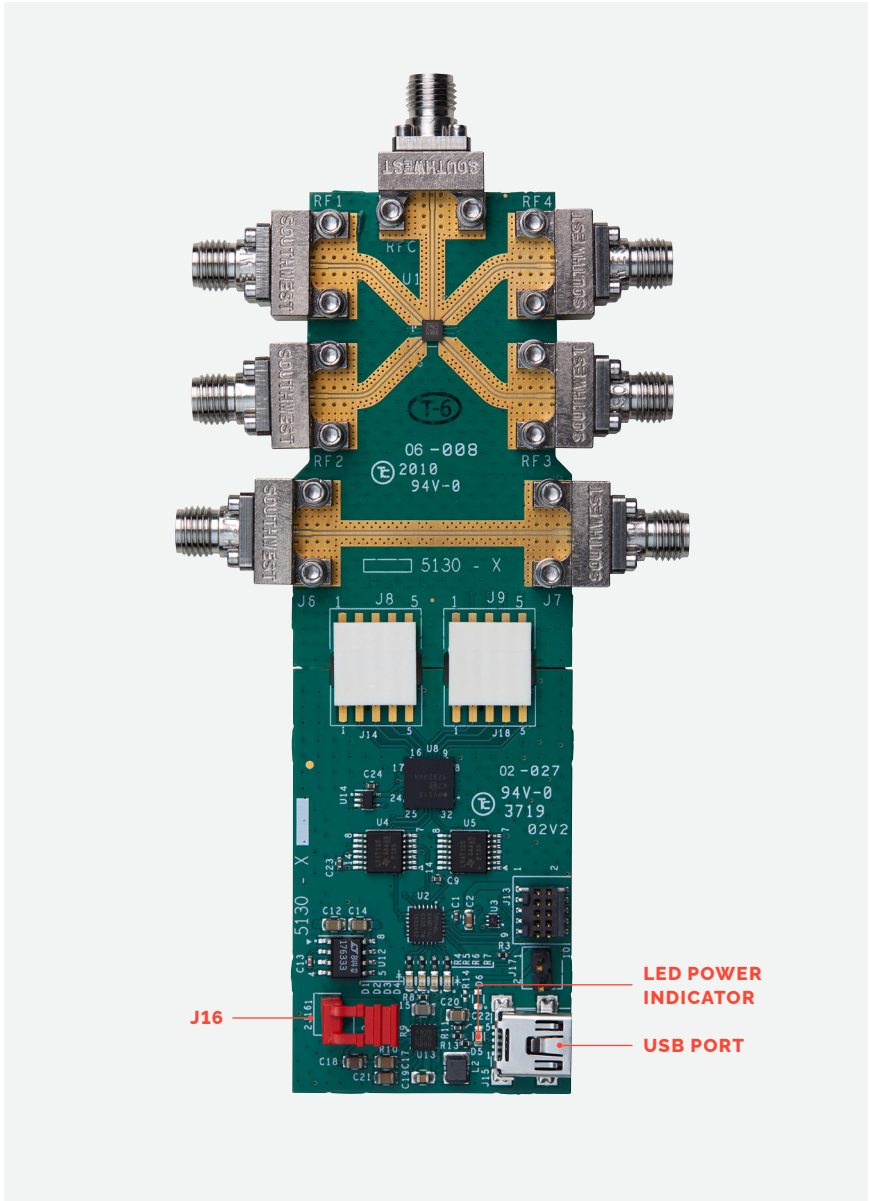

FIG. 1 MM5130 EVK and Driver Board

STEP-BY-STEP

PROCEDURE:

1. Using the files found on the USB memory stick included in this kit, install the Menlo Micro EVK Control Software to your computer.
2. In an ESD protected environment, remove the MM5130 board from the ESD bag. Ensure jumper J16 is installed as shown in Fig. 1.
3. Install the USB cable between the Evaluation Board and your computer. The angled mini-USB provides clearance between the connector and RF measurement cables. When the EVK is connected to the Computer, the LED Power Indicator lights up at the presence of 5.0 V supply voltage from the computer.
4. With the USB cable connected, start the Menlo Micro EVK Control Software which will scan the connected USB ports to find the Evaluation Board. Click on the "MM5130 EVK" button to confirm the correct board. If not detected, click on "Retry Port Scan."
5. The control GUI for the MM5130 will be shown and you can now control each of the 4 switches on the EVK. Note that LED indicators now indicate which switch is closed. Make sure there is no more than 0.5 V over the switch when it is closing or opening.



Perform all handling, installation and testing
in an ESD protected environment.

NOTE ON MEASUREMENT INSTRUMENTATION:

It is recommended to measure the evaluation board using a VNA. During evaluation it is best practice to open or close the device with zero voltage across the terminals. It is possible to open or close switches with up to 0.5 V across the terminals without lifetime degradation. See datasheet (available at MenloMicro.com) for full hot switching specification details. Opening or closing the switch with a VNA sweep active is generally a safe practice.



Even using a common digital multimeter to check the resistance can lead to device damage if the measurement is active during the actual state transition. Voltages between 3.0 V and 7.0 V from Multi-Meters (DMM) have been observed.

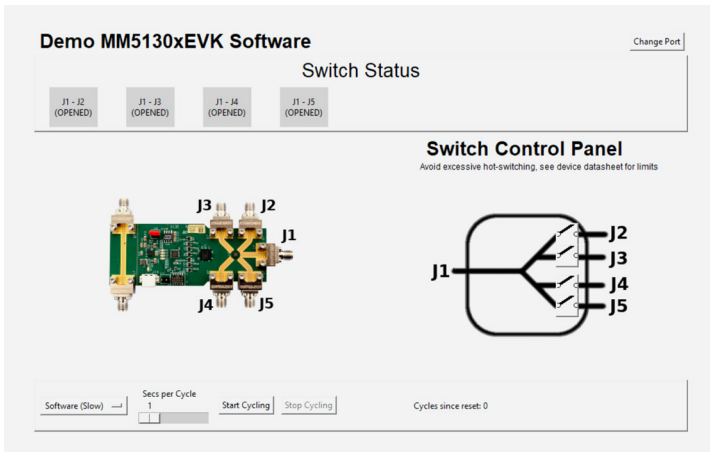

FIG. 2 Software with no EVK connected