



menlo**micro**

MM5600 EVK1 R1.0

Evaluation Kit Instructions
March 2021

Introduction to MM560 EVK1 Revision 1.0

Revision 1.0 is an easy to use EVK enables access to all channels of the M5600 with equal length GCPW lines and SMA connectors.

The top layer of the PCB where the RF traces are located is fabricated from a low loss dielectric.

Note: The attached board with RF lines should not be used as a calibration board for the VNA, it is intended to help model the equal length RF lines. A rudimentary amplitude de-embedding can be accomplished by measuring the 2X Thru lines and doing relative measurement of the insertion loss.

To simplify the evaluation process, the EVK features power and control over the USB connector. No external power supply is required.

NOTE ON MEASUREMENT INSTRUMENTATION:

The MM5600 devices are ESD sensitive devices. Wrist strap and ESD safe work surfaces must be used.

During evaluation it is best practice to open or close the device with zero voltage across the terminals. It is possible to open or close switches with up to 0.5 V across the terminals without lifetime degradation. See datasheet (available at MenloMicro.com) for full hot switching specification details. Opening or closing the switch with a VNA sweep active in generally a safe practice.

For resistance measurements, a DMM may be used to measure the switch once it is turned on. The center connector of the SMA is a good place to attach the test leads.

Starting up the EVK

In an ESD safe environment, remove the EVK from the ESD bag.

Install the control software from the included USB memory stick. An automatic installer is provided.

Connect the EVK and the computer with the USB cable. A small LED on the EVK should light up and indicate presence of 5.0 V.

Start the software and select the board you are using (MM5600 EVK1 R1.0)
A control screen shows channel assignment and status of all switches.

A VNA can be used for RF performance evaluation.

High performance BERT and wide-band oscilloscope can be used to perform differential eye diagram tests for high speed differential signaling protocols.

MM5600 EVK1 WITH ATTACHED DRIVER BOARD

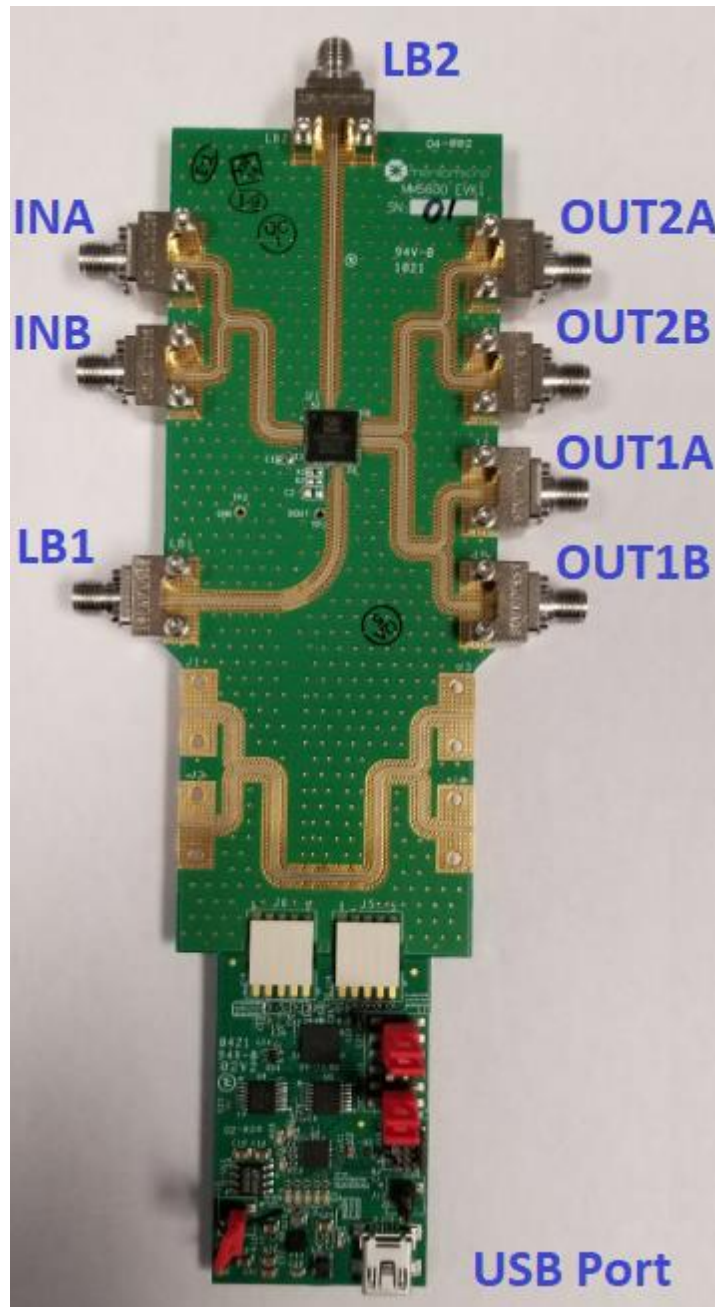

STEP-BY-STEP PROCEDURE:

1 . Using the files found on the USB memory stick included in this kit, install the Menlo Micro EVK Control Software to your computer.

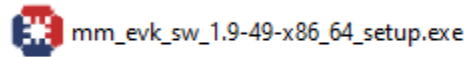

2 . In an ESD protected environment, remove the MM5600 board from the ESD bag.

3. Install the USB cable between the Evaluation Board and your computer. The angled mini-USB provides clearance between the connector and RF measurement cables. When the EVK is connected to the Computer, the LED Power Indicator lights up at the presence of 5.0 V supply voltage from the computer.

4. With the USB cable connected, start the Menlo Micro EVK Control Software which will scan the connected USB ports to find the Evaluation Board. Click on the “USB MM5600” button to confirm the correct board. If not detected, click on “Retry Port Scan.”

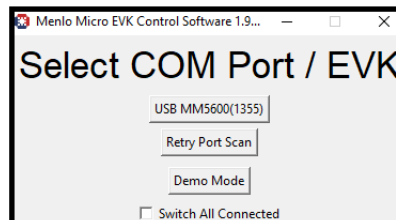

5. The control GUI for the MM5600 will be shown and you can now control the switches on the EVK. Note that LED indicators now indicate which switch is closed.

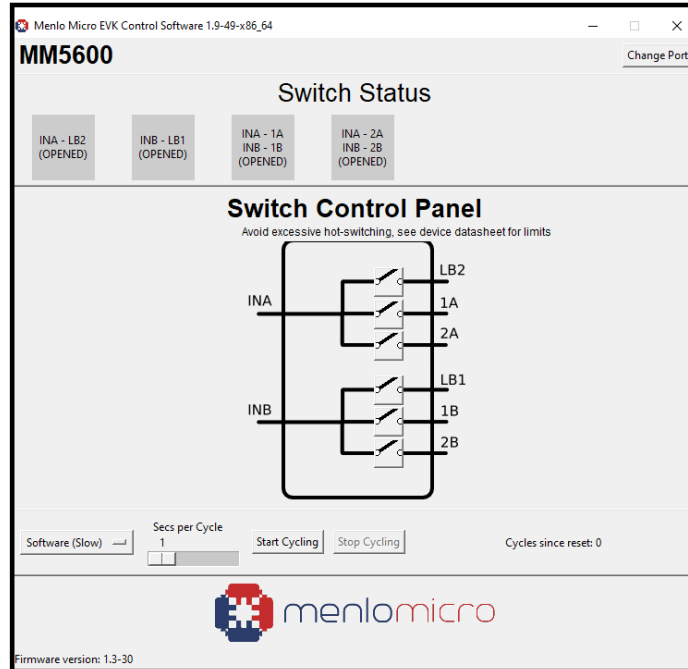

6. To connect the input ports (INA and INB) to the output ports (1A and 1B), click on either “INA_1A” switch or “INB-1B” switch, then both switches are on/off together.

