

MMA044PP3

Datasheet

**6 GHz–18 GHz GaAs pHEMT MMIC Wideband Low-Noise
Amplifier**

Released

May 2017



Contents

1	Revision History	1
1.1	Revision 1.0	1
2	Product Overview	2
2.1	Applications	2
2.2	Key Features	2
3	Electrical Specifications	3
3.1	Absolute Maximum Ratings	3
3.2	Specified Electrical Performance	4
3.3	Typical Performance Curves	4
4	Package Specifications	6
4.1	Package Outline Drawing	6
4.2	Package Information	6
4.3	Pin Descriptions	7
4.4	Application Circuit	7
5	Handling Recommendations	8
6	Evaluation Board Information	9
7	Ordering Information	10

1 Revision History

The revision history describes the changes that were implemented in the document. The changes are listed by revision, starting with the most current publication.

1.1 Revision 1.0

Revision 1.0 was published in May 2017. It was the first publication of this document.

2 Product Overview

The MMA044PP3 is a gallium arsenide (GaAs) pseudomorphic high-electron-mobility transistor (pHEMT) low-noise wideband amplifier in a plastic leadless 3 mm × 3 mm surface-mount package that operates between 6 GHz and 18 GHz. The MMA044PP3 amplifier provides 17 dB of gain, 2.0 dB noise figure, 14 dBm P1dB, and 28 dBm output IP3. The amplifier draws only 100 mA of current from a 4 V supply. The P1dB power of 14 dBm enables the LNA to function as an LO driver. The RF input and output ports of the amplifier are DC blocked and internally matched to 50 Ω. This product is also available in die format as the MMA044AA.

The following illustration shows the primary functional diagram of the MMA044PP3 device.

Figure 1 • MMA044PP3 Functional Block Diagram

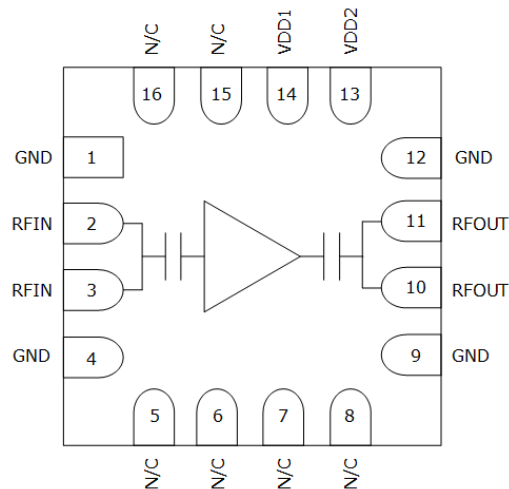

2.1 Applications

The MMA044PP3 device is designed for the following applications:

- Test and measurement instrumentation
- Electronic warfare (EW), electronic countermeasures (ECM), and electronic counter-countermeasures (ECCM)
- Wideband communications
- Military and space systems
- Telecom infrastructure
- Microwave and millimeter-wave communications systems

2.2 Key Features

The following are key features of the MMA044PP3 device:

- GaAs pHEMT LNA monolithic microwave integrated circuit (MMIC)
- Low-noise figure: 2.0 dB from 6 GHz–12 GHz
- 50 Ω matched input/output
- High gain: 17 dB from 6 GHz–18 GHz
- Broadband performance: 6 GHz–18 GHz
- Excellent P1dB output power: 14 dBm
- High OIP3: 28 dBm
- Single-supply operation: 4 V
- Package: compact 16-lead 3 mm × 3 mm × 0.85 mm QFN package

3 Electrical Specifications

This section details the electrical specifications of the MMA044PP3 device.

3.1 Absolute Maximum Ratings

The following table shows the absolute maximum ratings of the MMA044PP3 device.

Table 1 • Absolute Maximum Ratings

Parameter	Rating
Storage temperature	–65 °C to 150 °C
Operating temperature	–40 °C to 85 °C
Drain bias voltage (V_{D1} , V_{D2})	4.5 V
Channel temperature	150 °C
ESD sensitivity (HBM)	TBD
Thermal impedance (channel-to-die backside)	TBD

3.2 Specified Electrical Performance

The following table shows the specified electrical performance of the MMA044PP3 device at 25 °C, where V_{D1} and V_{D2} are 4 V, I_{D1} is 30 mA, and I_{D2} is 70 mA.

Table 2 • Specified Electrical Performance

Parameter	Frequency Range	Min	Typ	Max	Units
Operational frequency range		5		19	GHz
Gain	6 GHz–18 GHz	16	17		dB
Gain flatness	6 GHz–18 GHz		±0.5		dB
Noise figure	6 GHz–12 GHz		2.0	2.5	dB
	12 GHz–18 GHz		2.5	3.5	dB
Input return loss	6 GHz–18 GHz		–12		dB
Output return loss	6 GHz–18 GHz		–12		dB
P1dB	6 GHz–18 GHz		14		dBm
Psat (3 dB compression point)	6 GHz–18 GHz		16		dBm
OIP3	6 GHz–18 GHz		28		dBm
V_{D1} (drain voltage supply)			4		V
V_{D2} (drain voltage supply)			4		V
I_{D1} (drain current nominal)		25	30	35	mA
I_{D2} (drain current nominal)		63	70	78	mA

3.3 Typical Performance Curves

The following graphs show the typical electrical performance curves of the MMA044PP3 device, where V_{DD} is 4 V and I_{DD} is 100 mA, unless otherwise indicated.

Figure 2 • Gain vs. Temperature

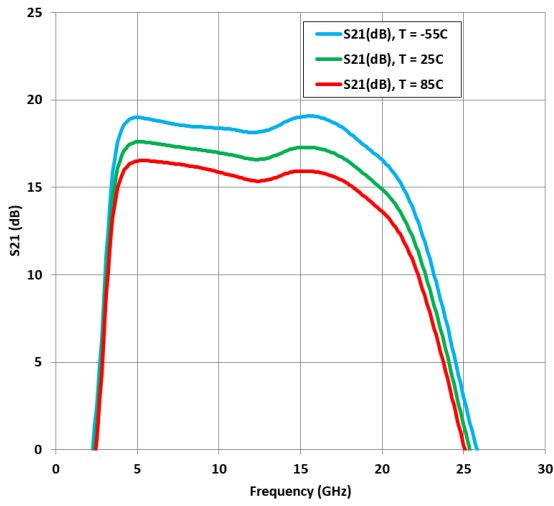

Figure 3 • Noise Figure vs. Temperature

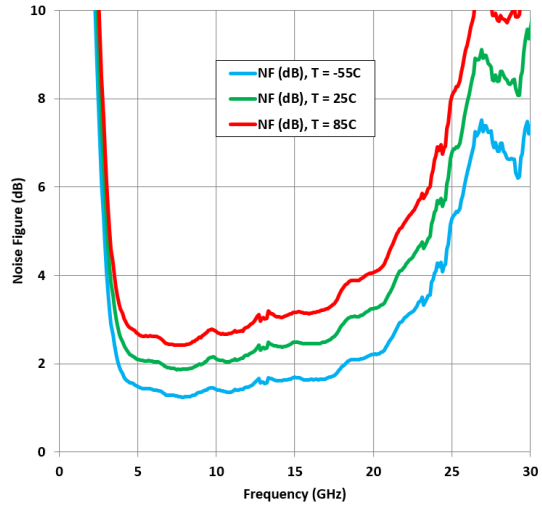

Figure 4 • Input Return Loss vs. Temperature

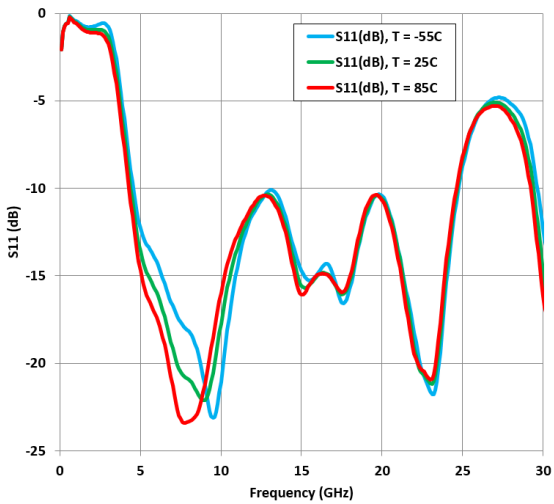

Figure 5 • Output Return Loss vs. Temperature

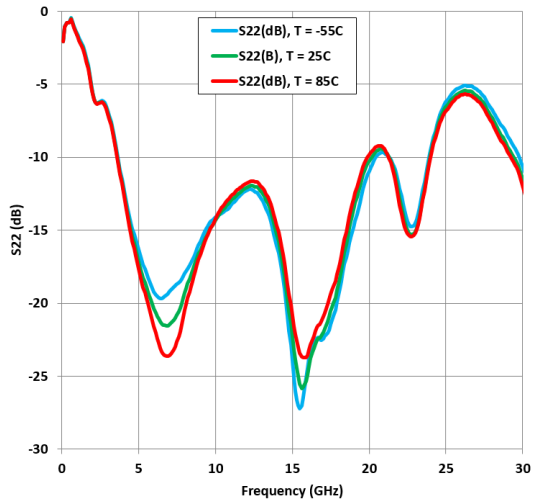

Figure 6 • P1dB/P3dB Output Power vs. Temperature

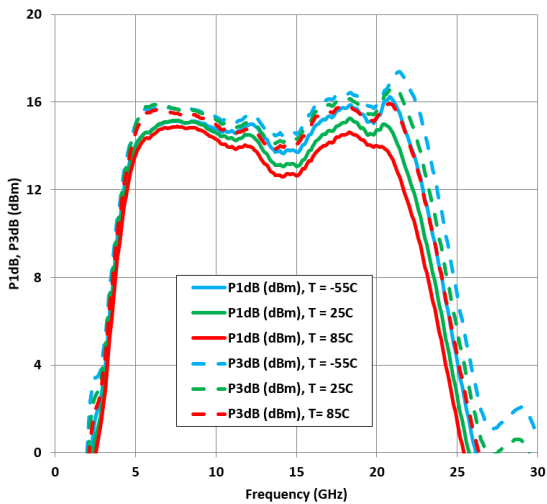
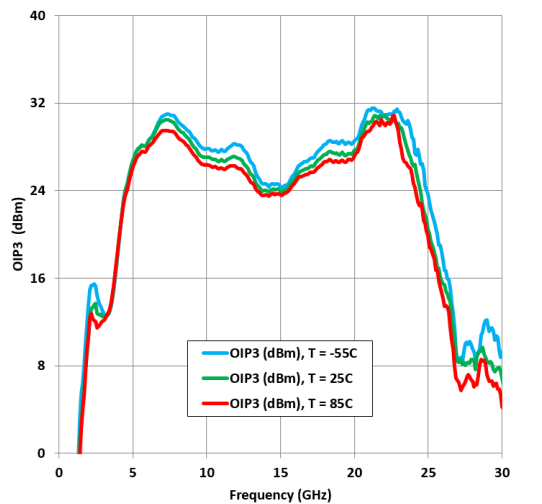

Figure 7 • Output IP3 vs. Temperature



4 Package Specifications

This section details the package specifications of the MMA044PP3 device.

4.1 Package Outline Drawing

The following illustration shows the package outline of the MMA044PP3 device. Dimensions are in millimeters [inches].

Figure 8 • Package Outline

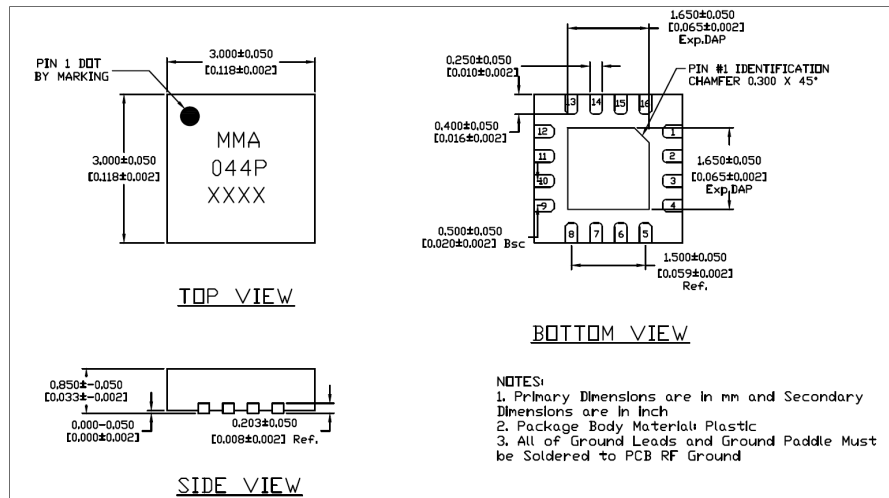

4.2 Package Information

The following table shows the package information of the MMA044PP3 device. For additional packaging information, contact your Microsemi sales representative.

Table 3 • Package Information

Part Number	Package Body Material	Lead Finish	MSL Rating	Package Marking
MMA044PP3	Low-stress injection molded plastic	100% matte Sn	TBD	MMA 044P wwyy

4.3 Pin Descriptions

The following table provides descriptions of pins for the MMA044PP3 device.

Table 4 • Pin Descriptions

Pin Number	Pin Name	Description
1,4,9,12	GND	GND pins and package bottom must be connected to external RF/DC ground on PCB.
2,3	RFIN	This pin is AC-coupled and matched to 50 Ω .
5,6,7,8,15,16	N/C	These pins are not connected internally, but they may be connected to external RF/DC ground on PCB.
10,11	RFOUT	This pin is AC-coupled and matched to 50 Ω .
13,14	VDD2, VDD1	Power supply voltage for the amplifier. See assembly for required external components.
Backside paddle	RF/DC GND	RF/DC ground.

4.4 Application Circuit

The following illustration shows the application circuit schematic for the MMA044PP3 device.

Figure 9 • Application Circuit Schematic

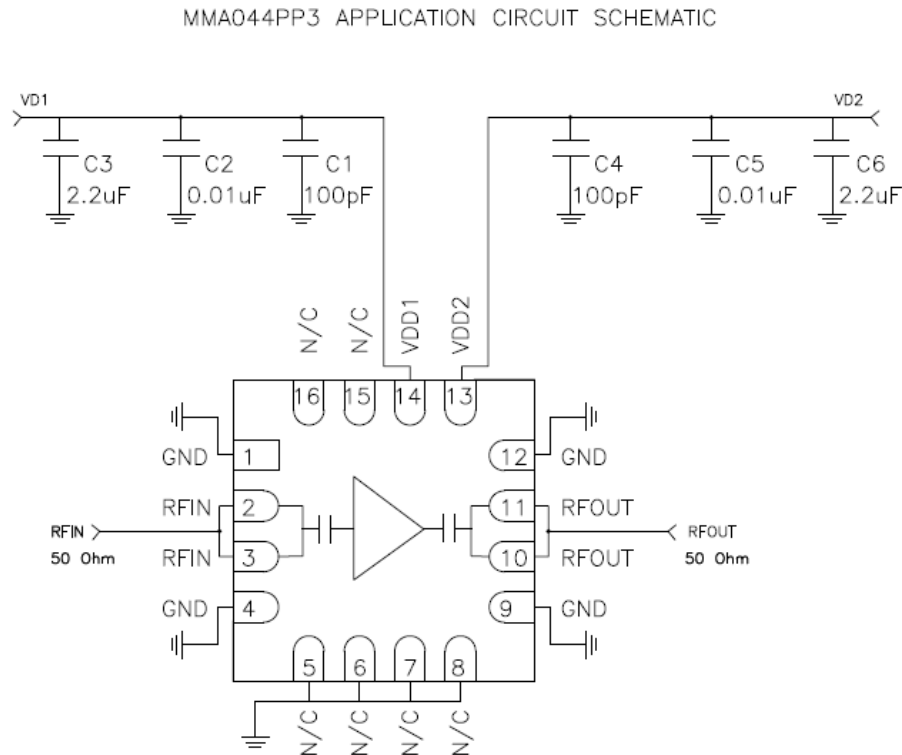

5 Handling Recommendations

Gallium arsenide integrated circuits are sensitive to electrostatic discharge (ESD) and can be damaged by static electricity. It is recommended to follow all procedures and guidelines outlined in the Microsemi application note [AN01 GaAs MMIC Handling and Die Attach Recommendations](#).

6 Evaluation Board Information

The following image shows the evaluation board of the MMA044PP3 device.

Figure 10 • Evaluation Board

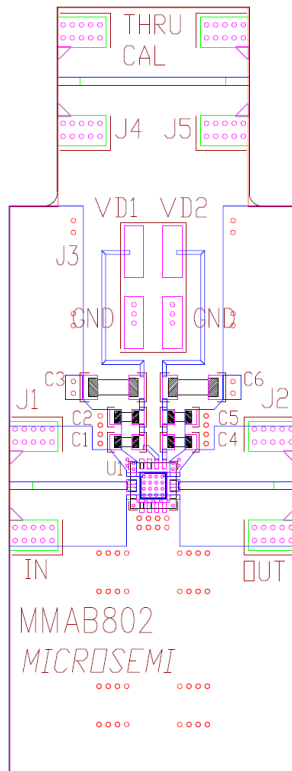

The circuit board used in the application should be generated with proper RF circuit design techniques. Signal lines at the RF ports should have 50 Ω impedance and the package ground leads and backside ground paddle should be connected directly to the ground plane similar to that shown previously.

The following table shows the materials for the evaluation PCB MMA044PP3E.

Table 5 • Materials for Evaluation PCB MMA044PP3E

Item	Description
C1, C4	0603, 100 pF, $\pm 5\%$, 100 V, AVX, NPO
C2, C5	0603, 10000 pF, $\pm 10\%$, 100 V, AVX, X7R
C3, C6	1206, 2.2 μ F, $\pm 10\%$, 50 V, AVX, X7R
J1, J2, J4, J5	SRI RF connector 2.9 mm
J3	4-pin DC header Molex
U1	MMA044PP3 QFN 3X3, 16L
PCB	MMAB802
Base plate	749-MM-0198_Rev 03 (modified)

7 Ordering Information

The following table shows the ordering information for the MMA044PP3 device.

Table 6 • Ordering Information

Part Number	Package
MMA044PP3	3 mm × 3 mm plastic QFN package
MMA044PP3E	Evaluation board for MMA044PP3