

Features

- Epitaxial Planar Die Construction
- Halogen Free. "Green" Device (Note 1)
- Moisture Sensitivity Level 1
- Epoxy Meets UL 94 V-0 Flammability Rating
- Lead Free Finish/RoHS Compliant ("P" Suffix Designates RoHS Compliant. See Ordering Information)

Maximum Ratings @ 25°C Unless Otherwise Specified

- Operating Junction Temperature Range: -55°C to +150°C
- Storage Temperature Range: -55°C to +150°C
- Typical Thermal Resistance: 833°C/W Junction to Ambient

Parameter	Symbol	Rating	Unit
Collector-Base Voltage	V_{CBO}	-40	V
Collector-Emitter Voltage	V_{CEO}	-40	V
Emitter-Base Voltage	V_{EBO}	-5	V
Collector Current	I_C	-200	mA
Collector Power Dissipation	P_C	150	mW

Note: 1. Halogen free "Green" products are defined as those which contain <900ppm bromine, <900ppm chlorine (<1500ppm total Br + Cl) and <1000ppm antimony compounds.

Internal Structure

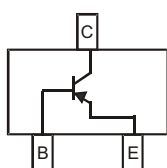

Marking: 3N

PNP General Purpose Amplifier

SOT-523

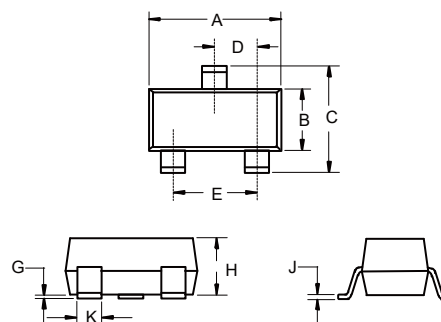

DIM	DIMENSIONS				NOTE
	INCHES		MM		
	MIN	MAX	MIN	MAX	
A	0.059	0.067	1.50	1.70	
B	0.030	0.033	0.75	0.85	
C	0.057	0.069	1.45	1.75	
D	0.020		0.50		TYP.
E	0.035	0.043	0.90	1.10	
G	0.000	0.004	0.00	0.10	
H	0.024	0.031	0.60	0.80	
J	0.004	0.008	0.10	0.20	
K	0.006	0.014	0.15	0.35	

Suggested Solder Pad Layout

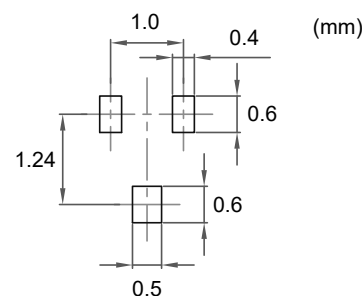

Electrical Characteristics @ 25°C Unless Otherwise Specified

Parameter	Symbol	Min	Typ	Max	Units	Conditions
Collector-Base Breakdown Voltage	$V_{(BR)CBO}$	-40			V	$I_C = -10\mu A, I_E = 0$
Collector-Emitter Breakdown Voltage	$V_{(BR)CEO}$	-40			V	$I_C = -1mA, I_B = 0$
Emitter-Base Breakdown Voltage	$V_{(BR)EBO}$	-5			V	$I_E = -10\mu A, I_C = 0$
Collector-Base Cutoff Current	I_{CBO}			-50	nA	$V_{CB} = -30V, I_E = 0$
Emitter-Base Cutoff Current	I_{EBO}			-50	nA	$V_{EB} = -5V, I_C = 0$
DC Current Gain	$h_{FE(1)}$	60				$V_{CE} = -1V, I_C = -0.1mA$
	$h_{FE(2)}$	80				$V_{CE} = -1V, I_C = -1mA$
	$h_{FE(3)}$	100		300		$V_{CE} = -1V, I_C = -10mA$
	$h_{FE(4)}$	60				$V_{CE} = -1V, I_C = -50mA$
	$h_{FE(5)}$	30				$V_{CE} = -1V, I_C = -100mA$
Collector-Emitter Saturation Voltage	$V_{CE(sat)}$			-0.25	V	$I_C = -10mA, I_B = -1mA$
				-0.4	V	$I_C = -50mA, I_B = -5mA$
Base-Emitter Saturation Voltage	$V_{BE(sat)}$	-0.65		-0.85	V	$I_C = -10mA, I_B = -1mA$
				-0.95	V	$I_C = -50mA, I_B = -5mA$
Transition Frequency	f_T	250			MHz	$V_{CE} = -20V, I_C = -10mA, f = 100MHz$
Output Capacitance	C_{obo}			4.5	pF	$V_{CB} = -5V, I_E = 0, f = 1MHz$
Input Capacitance	C_{ibo}			10	pF	$V_{BE} = -0.5V, I_C = 0, f = 1KHz$
Noise Figure	NF			4	dB	$V_{CE} = -5V, I_C = -100\mu A$ $RS = 1K\Omega, f = 1MHz$
Delay Time	t_d			35	ns	$V_{CC} = -3V, V_{BE} = -0.5V$
Rise Time	t_r			35	ns	$I_C = -10mA, I_{B1} = -1mA$
Storage Time	t_s			225	ns	$V_{CC} = -3V, I_C = -10mA$
Fall Time	t_f			75	ns	$I_{B1} = I_{B2} = -1mA$

Curve Characteristics

Fig. 1 - Static Characteristics

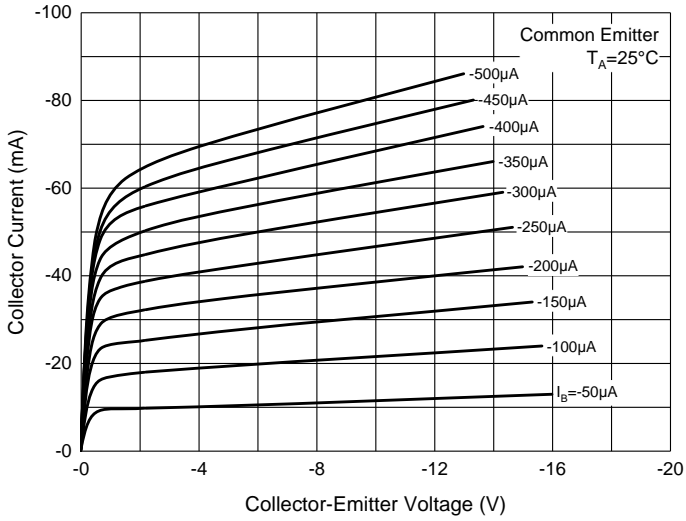

Fig. 2 - DC Current Gain Characteristics

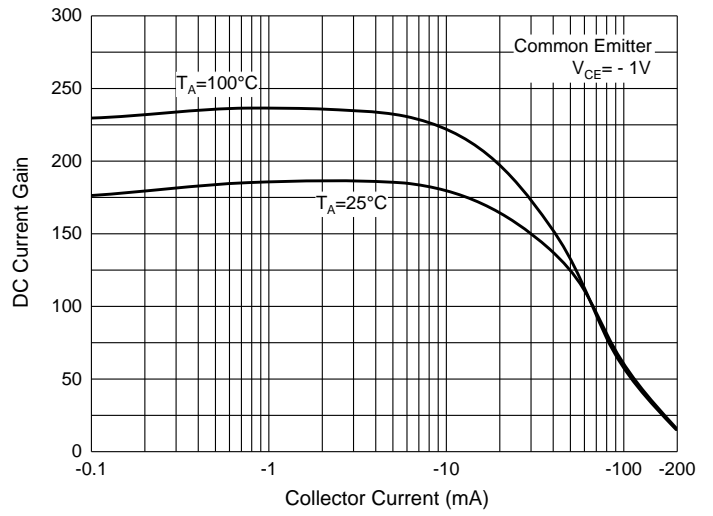

Fig. 3 - Collector-Emitter Saturation Voltage Characteristics

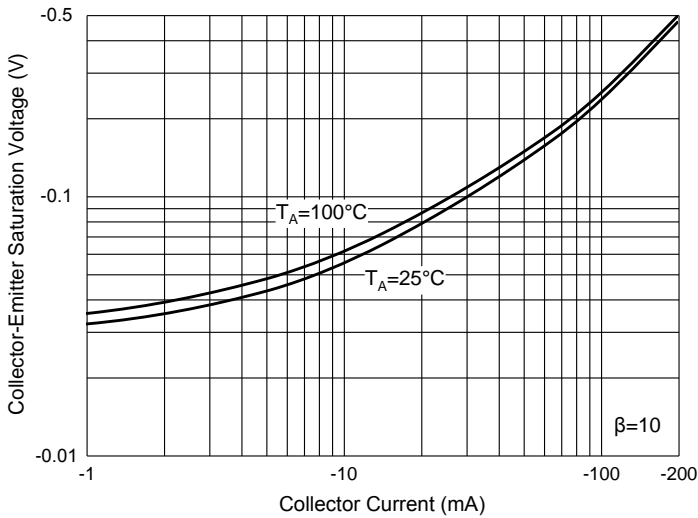

Fig. 4 - Base-Emitter Saturation Voltage Characteristics

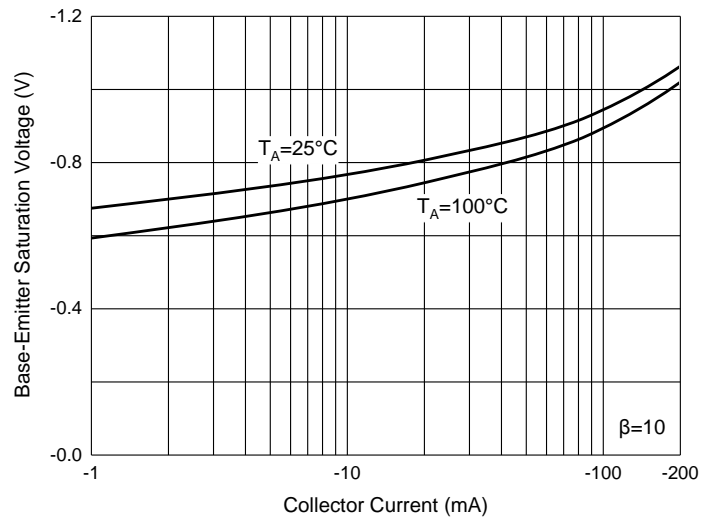

Fig. 5 - Base-Emitter Voltage Characteristics

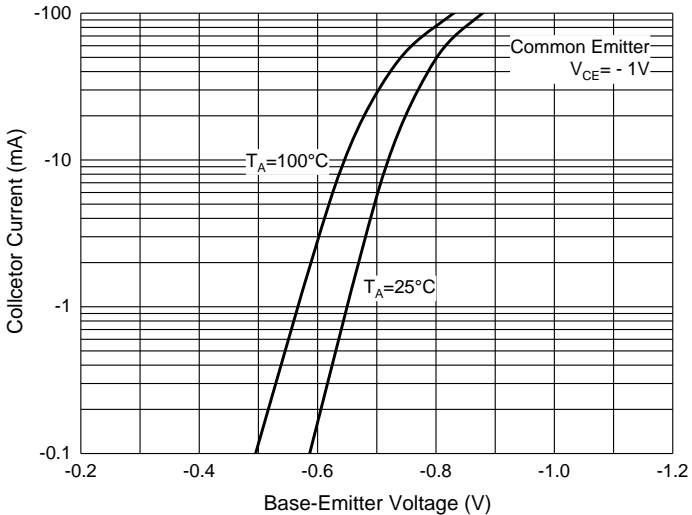

Fig. 6 - Collector Power Derating Curve

