

MMBT4401-G (NPN) RoHS Device

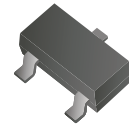

Features

-Switching Transistor

Circuit Diagram

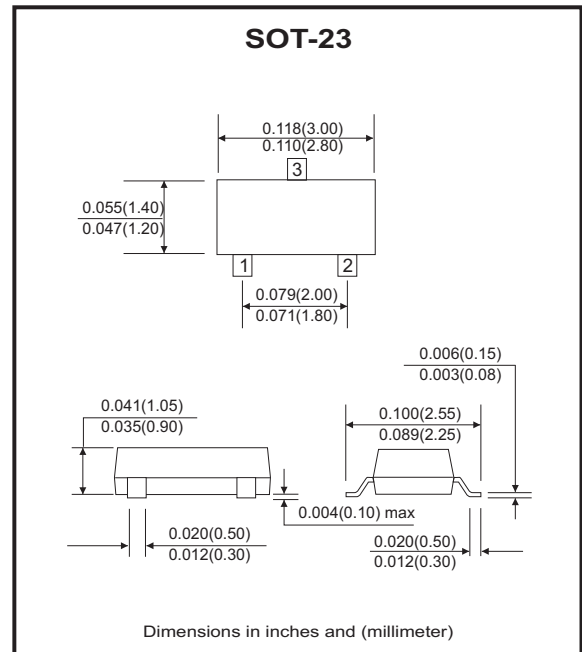
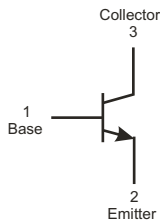

Maximum Ratings (at Ta=25°C unless otherwise noted)

Parameter	Symbol	Value	Units
Collector-Base voltage	V_{CBO}	60	V
Collector-Emitter voltage	V_{CEO}	40	V
Emitter-Base voltage	V_{EBO}	6	V
Collector current	I_C	600	mA
Collector power dissipation	P_C	300	mW
Thermal resistance, junction to ambient	$R_{\theta JA}$	417	°C/W
Junction temperature	T_J	150	°C
Storage temperature range	T_{STG}	-55 to +150	°C

Company reserves the right to improve product design , functions and reliability without notice.

Electrical Characteristics (@TA=25°C unless otherwise noted)

Parameter	Symbol	Conditions	Min.	Max.	Units
Collector-Base breakdown voltage	$V_{(BR)CBO}$	$I_C=100\mu A, I_E=0$	60		V
Collector-Emitter breakdown voltage	$V_{(BR)CEO}$	$I_C=1mA, I_B=0$	40		V
Emitter-Base breakdown voltage	$V_{(BR)EBO}$	$I_E=100\mu A, I_C=0$	6		V
Collector cut-off current	I_{CEO}	$V_{CE}=30V, I_B=0$		100	nA
Collector cut-off current	I_{CBO}	$V_{CB}=50V, I_E=0$		100	nA
Base cut-off current	I_{EBO}	$V_{EB}=5V, I_C=0$		100	nA
DC current gain	h_{FE}	$V_{CE}=1V, I_C=150mA$	100	300	
Collector-Emitter saturation voltage	$V_{CE(sat)}$	$I_C=150mA, I_B=15mA$		0.4	V
Base-Emitter saturation voltage	$V_{BE(sat)}$	$I_C=150mA, I_B=15mA$		0.95	V
Transition frequency	f_T	$V_{CE}=10V, I_C=20mA$ $f=100MHz$	250		MHz
Delay time	t_d	$V_{CC}=30V, V_{BE(off)}=-2V,$ $I_C=150mA, I_{B1}=15mA$		15	nS
Rise time	t_r			20	nS
Storage time	t_s	$V_{CC}=30V, I_C=150mA$ $I_{B1}=I_{B2}=15mA$		225	nS
Fall time	t_f			30	nS

Company reserves the right to improve product design , functions and reliability without notice.

RATING AND CHARACTERISTIC CURVES (MMBT4401-G)

Fig.1 - Static Characteristic

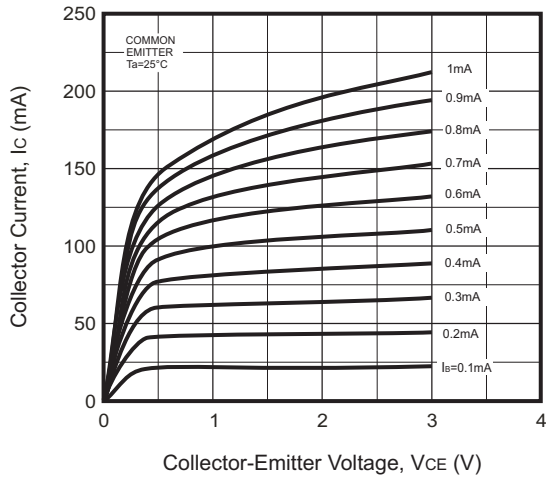

Fig.2 - $h_{FE} - I_c$

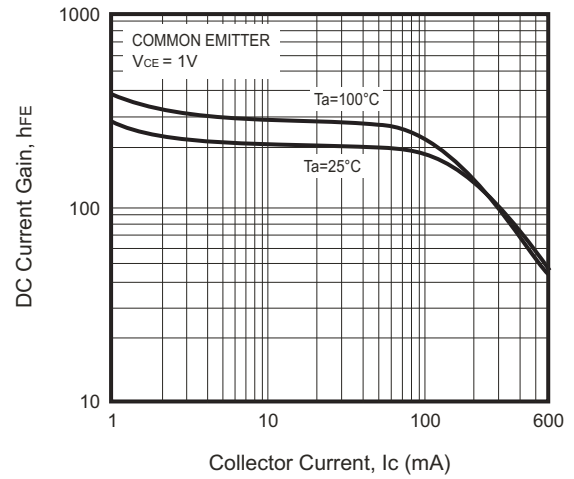

Fig.3 - $V_{CEsat} - I_c$

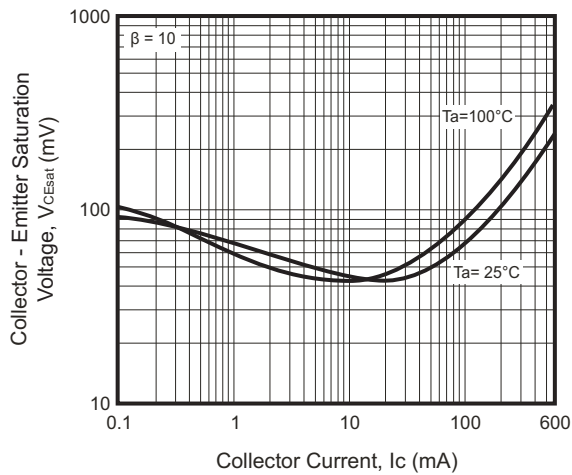
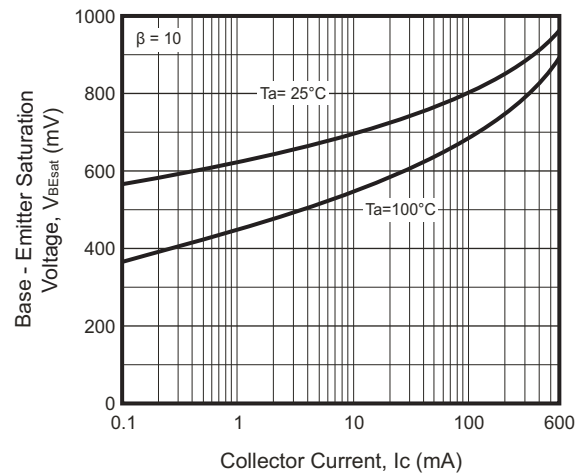

Fig.4 - $V_{BEsat} - I_c$



Company reserves the right to improve product design , functions and reliability without notice.

RATING AND CHARACTERISTIC CURVES (MMBT4401-G)

Fig.5 - I_c — V_{BE}

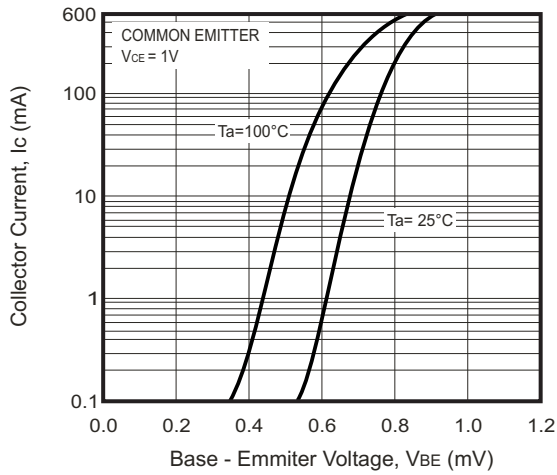

Fig.6 - f_T — I_c

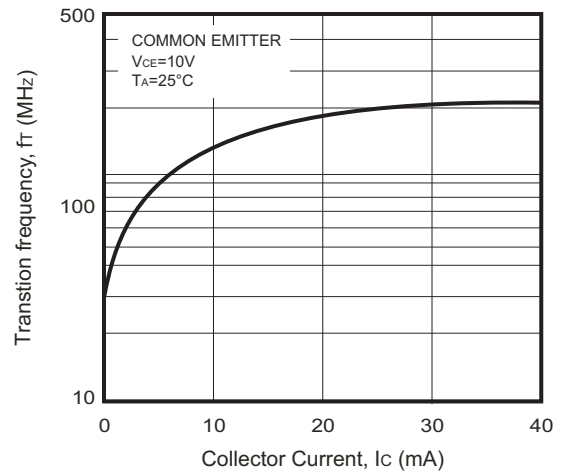

Fig.7 - C_{ob}/C_{ib} — V_{CB}/V_{EB}

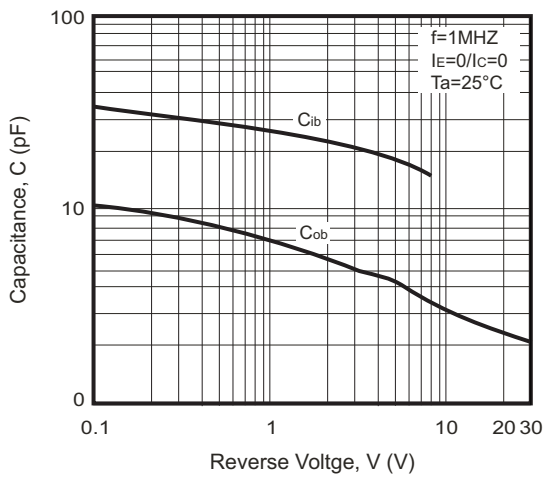
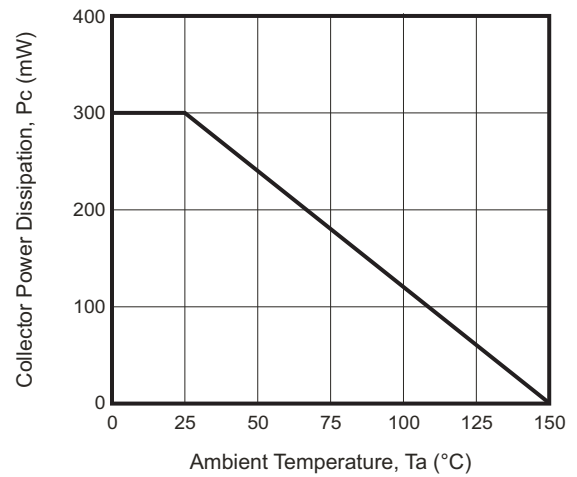
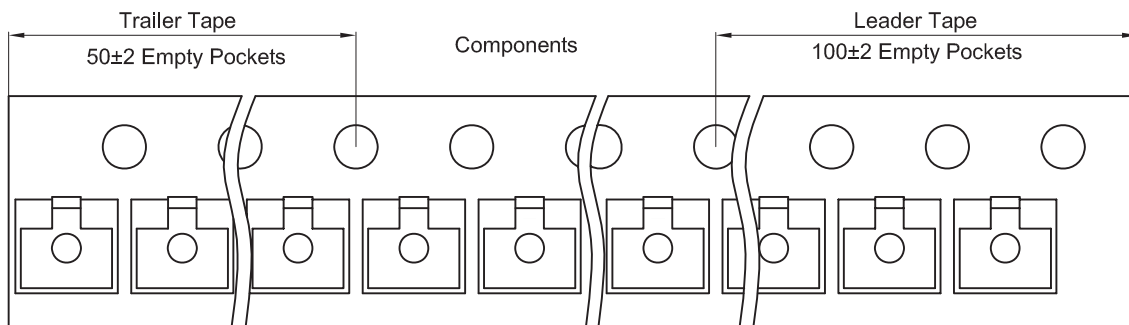
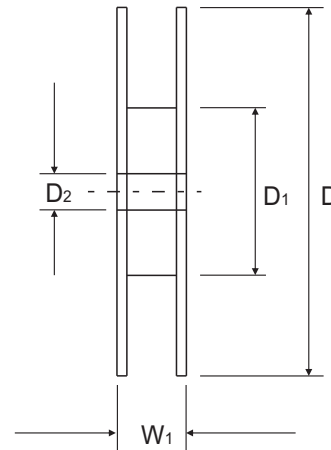
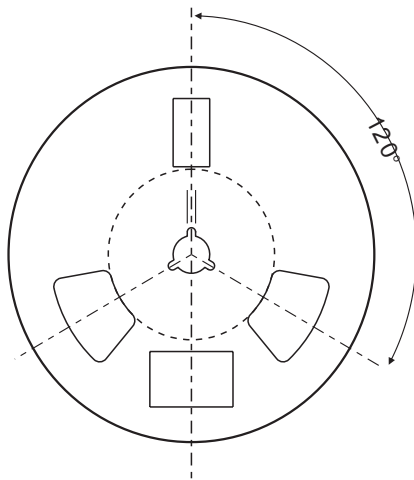
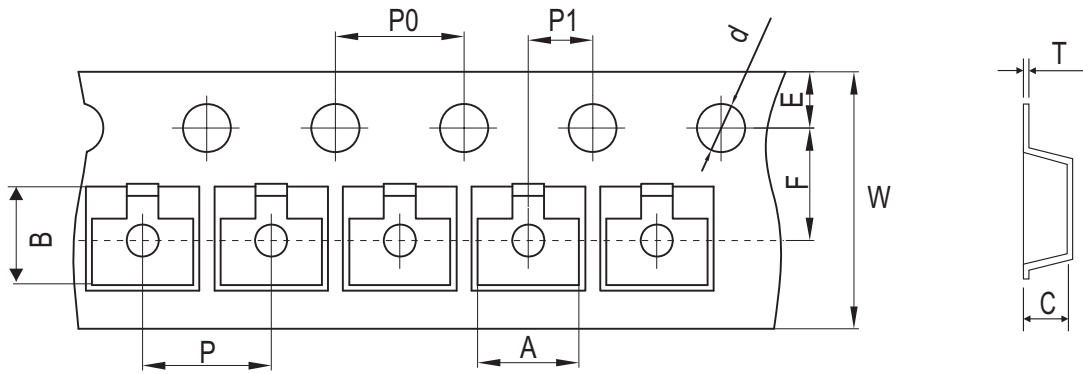

Fig.8 - P_c — T_a



Company reserves the right to improve product design , functions and reliability without notice.

Reel Taping Specification



SOT-23	SYMBOL	A	B	C	d	D	D1	D2
	(mm)	3.15 ± 0.10	2.77 ± 0.10	1.22 ± 0.10	Φ1.50 ± 0.10	178 ± 2.00	54.40 ± 1.00	13.00 ± 1.00
	(inch)	0.124 ± 0.004	0.109 ± 0.004	0.048 ± 0.004	Φ0.059 ± 0.004	7.008 ± 0.079	2.142 ± 0.039	0.512 ± 0.039

SOT-23	SYMBOL	E	F	P	P0	P1	W	W1
	(mm)	1.75 ± 0.10	3.50 ± 0.10	4.00 ± 0.10	4.00 ± 0.10	2.00 ± 0.10	8.00 + 0.30 / - 0.10	12.30 ± 1.00
	(inch)	0.069 ± 0.004	0.138 ± 0.004	0.157 ± 0.004	0.157 ± 0.004	0.079 ± 0.004	0.315 + 0.012 / - 0.004	0.484 ± 0.039

Company reserves the right to improve product design, functions and reliability without notice.