

Features

- High Current Gain Bandwidth Product
- Designed for VHF/UHF Amplifier Applications and High Output VHF Oscillators
- Halogen Free. "Green" Device (Note 1)
- Moisture Sensitivity Level 1
- Epoxy Meets UL 94 V-0 Flammability Rating
- Lead Free Finish/RoHS Compliant ("P" Suffix Designates RoHS Compliant. See Ordering Information)

Maximum Ratings @ 25°C Unless Otherwise Specified

- Operating Junction Temperature Range: -55°C to +150°C
- Storage Temperature Range: -55°C to +150°C
- Thermal Resistance: 556°C/W Junction to Ambient

Parameter	Symbol	Rating	Unit
Collector-Base Voltage	V_{CBO}	30	V
Collector-Emitter Voltage	V_{CEO}	25	V
Emitter-Base Voltage	V_{EBO}	3	V
Continuous Collector Current	I_C	50	mA
Power Dissipation	P_D	225	mW

Note: 1. Halogen free "Green" products are defined as those which contain <900ppm bromine, <900ppm chlorine (<1500ppm total Br + Cl) and <1000ppm antimony compounds.

Marking: 3EM

Internal Structure

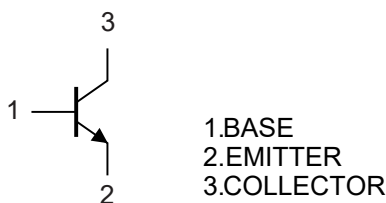

NPN VHF/UHF Transistors

SOT-23

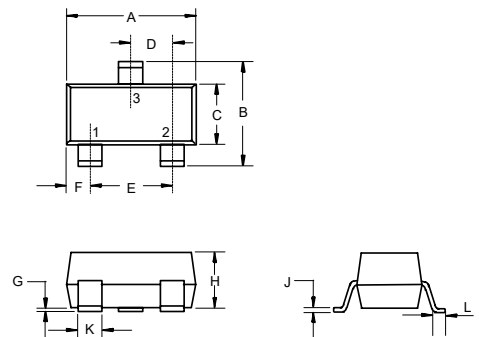

DIM	DIMENSIONS				NOTE
	INCHES		MM		
	MIN	MAX	MIN	MAX	
A	0.110	0.120	2.80	3.04	
B	0.083	0.104	2.10	2.64	
C	0.047	0.055	1.20	1.40	
D	0.034	0.041	0.85	1.05	
E	0.067	0.083	1.70	2.10	
F	0.018	0.024	0.45	0.60	
G	0.0004	0.006	0.01	0.15	
H	0.035	0.043	0.90	1.10	
J	0.003	0.007	0.08	0.18	
K	0.012	0.020	0.30	0.51	
L	0.007	0.020	0.20	0.50	

Suggested Solder Pad Layout

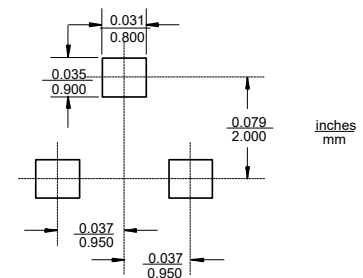

Electrical Characteristics @ $T_A=25^\circ\text{C}$ Unless Otherwise Specified

Parameter	Symbol	Min	Typ	Max	Units	Conditions
Collector-Base Breakdown Voltage	$V_{(BR)CBO}$	30			V	$I_C=100\mu\text{A}, I_E=0$
Collector-Emitter Breakdown Voltage	$V_{(BR)CEO}$	25			V	$I_C=1\text{mA}, I_B=0$
Emitter-Base Breakdown Voltage	$V_{(BR)EBO}$	3			V	$I_E=10\mu\text{A}, I_C=0$
Collector Cutoff Current	I_{CBO}			0.1	μA	$V_{CB}=25\text{V}, I_E=0$
Emitter Cutoff Current	I_{EBO}			0.1	μA	$V_{EB}=2\text{V}, I_C=0$
DC Current Gain	h_{FE}	60				$V_{CE}=10\text{V}, I_C=4\text{mA}$
Collector-Emitter Saturation Voltage	$V_{CE(sat)}$			0.5	V	$I_C=4\text{mA}, I_B=0.4\text{mA}$
Base-Emitter Saturation Voltage	$V_{BE(sat)}$			0.95	V	$I_C=4\text{mA}, V_{CE}=10\text{V}$
Transition Frequency	f_T	650			MHz	$V_{CE}=10\text{V}, I_C=4\text{mA}, f=100\text{MHz}$
Collector-Base Capacitance	C_{CB}			0.7	pF	$V_{CB}=10\text{V}, I_E=0, f=1\text{MHz}$
Collector-Base Feedback Capacitance	C_{RB}			0.65	pF	$V_{CB}=10\text{V}, I_E=0, f=1\text{MHz}$

Curve Characteristics

Fig. 1 - Static Characteristics

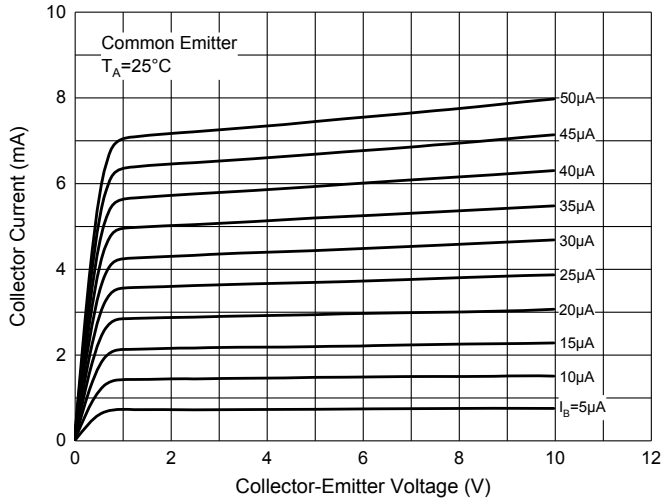

Fig. 2 - DC Current Gain Characteristics

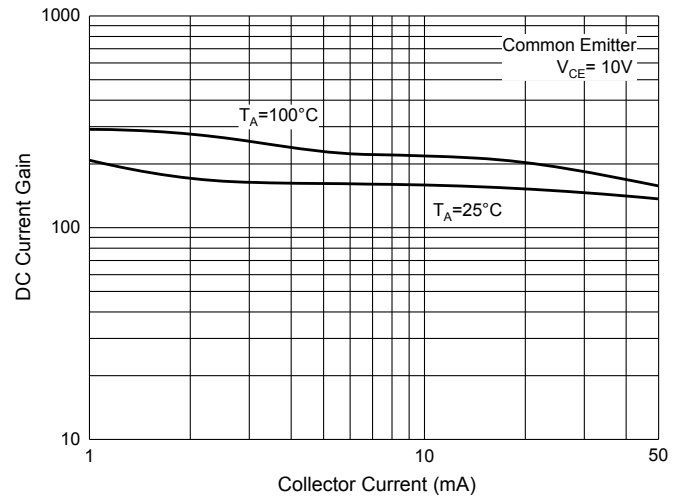

Fig. 3 - Collector-Emitter Saturation Voltage Characteristics

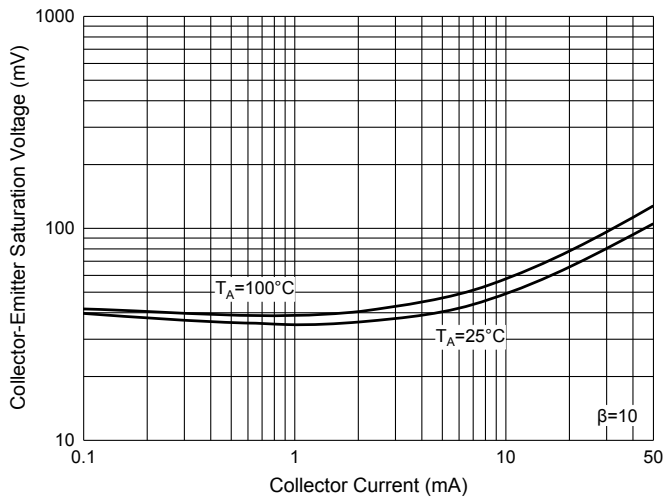

Fig. 4 - Base-Emitter Saturation Voltage Characteristics

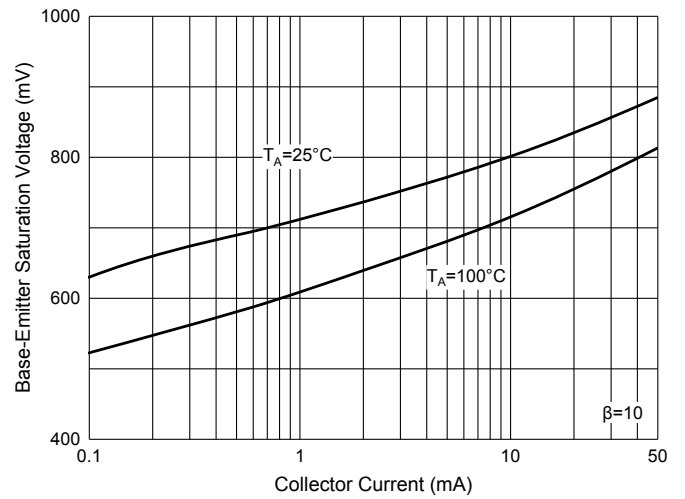

Fig. 5 - Base-Emitter Voltage Characteristics

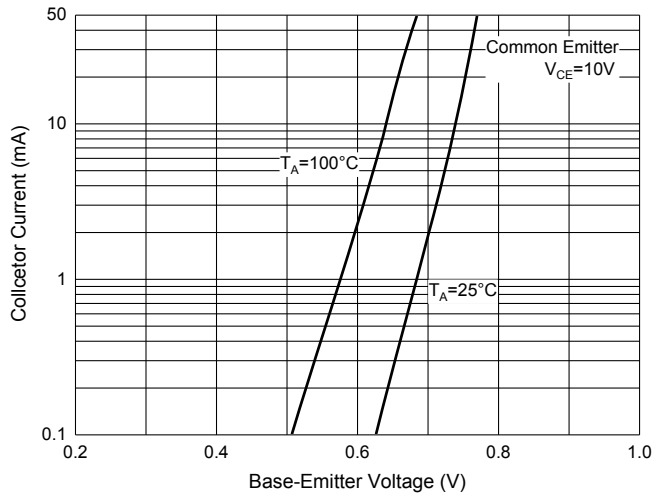

Fig. 6 - Collector Power Derating Curve

