



3-Bit Digital Step Attenuator

The MMT20303H is an integrated 3-bit digital step attenuator with a 1 dB step size. It is controlled via a 3-bit parallel interface and operates from a 3 to 5 V supply. The MMT20303H is suitable for 3G/4G small cell transmitter and mobile radio applications using frequencies from 50 to 4000 MHz.

Features

- Frequency: 50–4000 MHz
- Maximum RF Input Power: 30 dBm (CW)
- Typical IIP3 > 50 dBm
- Programmable Attenuator with 7 dB Maximum Range, 1 dB Step Size
- Low Insertion Loss
- ±0.1 dB Typical Bit Error
- Excellent Consistency over Temperature and Supply Voltage
- Single 3 to 5 V Supply
- 50 Ohm Operation
- P1dB Independent of Control Voltage
- 3-bit Digital Control
- TTL/CMOS Interface Compatible
- Cost-effective 16-pin, 3 mm QFN Surface Mount Plastic Package

MMT20303HT1

**50–4000 MHz, 3 Bit
 1 dB LSB**



**QFN 3 × 3
 PLASTIC**

Table 1. Typical Performance (1)

Characteristic	Symbol	250 MHz	900 MHz	4000 MHz	Unit
Insertion Loss	IL	-0.6	-0.7	-1.3	dB
Attenuation Accuracy (Worst Case State)	—	+0.1, -0.1	+0.1, 0	+0.1, -0.1	dB
Third Order Intercept Input Point (2)	IIP3	47	54	52	dBm
Power Input @ 1 dB Compression	P1dB	30	35 (3)	35 (3)	dBm

1. $V_{DD} = 5 \text{ Vdc}$, $T_A = 25^\circ\text{C}$, 50 ohm system, application circuit tuned for specific frequency.
2. Two-tone input power = +13 dBm each tone.
3. Operate within specified maximum rating.

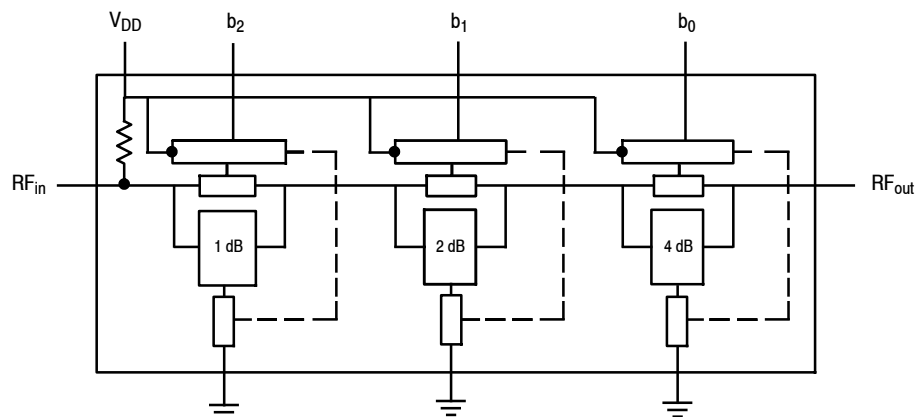

Figure 1. Functional Block Diagram

Table 2. Maximum Ratings

Rating	Symbol	Value	Unit
Supply Voltage	V_{DD}	6	V
RF Input Power	P_{in}	30	dBm
Storage Temperature Range	T_{stg}	-65 to +150	°C
Case Operating Temperature Range	T_C	-40 to +85	°C
Junction Temperature	T_J	175	°C

Table 3. Electrical Characteristics ($V_{DD} = 5$ Vdc, 900 MHz, $T_A = 25^\circ\text{C}$, 50 ohm system, in Freescale Application Circuit)

Characteristic	Symbol	Min	Typ	Max	Unit
Insertion Loss 1 (50–900 MHz)	IL_1	—	0.6	1.0	dB
Insertion Loss 2 (1000–2500 MHz)	IL_2	—	0.8	—	dB
Insertion Loss 3 (2500–4000 MHz)	IL_3	—	1.2	—	dB
Input Return Loss (S11)	IRL	—	20	—	dB
Output Return Loss (S22)	ORL	—	20	—	dB
Attenuation Control Maximum Range	ΔR	—	7	—	dB
Attenuation Step	ΔR^{step}	—	1	—	dB
Attenuation Accuracy	—	—	0.1	0.25	dB
Turn-on Time	t_{on}	—	60	—	ns
Turn-off Time	t_{off}	—	100	—	ns
Power Output @ 1dB Compression	P_{1dB}	—	35	—	dBm
Third Order Input Intercept Point @ 5 V	$IIP3_5$	—	50	—	dBm
Third Order Input Intercept Point @ 3 V	$IIP3_3$	—	50	—	dBm
Max Input Voltage Logic Low @ 100 μA , 3 V	V_{IL}	—	—	0.8	V
Min Input Voltage Logic High @ 100 μA , 3 V	V_{IH}	2.3	—	—	V
Supply Current @ 5 V	I_{DD}	—	2	3	mA

Table 4. ESD Protection Characteristics

Test Methodology	Class
Human Body Model (per JESD22-A114)	1A
Machine Model (per EIA/JESD22-A115)	A
Charge Device Model (per JESD22-C101)	III

Table 5. Moisture Sensitivity Level

Test Methodology	Rating	Package Peak Temperature	Unit
Per JESD22-A113, IPC/JEDEC J-STD-020	1	260	°C

Table 6. Ordering Information

Device	Tape and Reel Information	Package
MMT20303HT1	T1 Suffix = 1,000 Units, 12 mm Tape Width, 7-inch Reel	QFN 3 × 3

Table 7. Functional Pin Description

Pin Number	Pin Function	Pin Description
1, 3, 4, 5, 8, 9, 10, 12	N.C.	No Connection
2	RF _{in}	RF Input
6, 7	ACG (1)	AC Ground
11	RF _{out}	RF Output
13	b ₀	Attenuator Bit 0 (active low)
14	b ₁	Attenuator Bit 1 (active low)
15	b ₂	Attenuator Bit 2 (active low)
16	V _{DD}	Supply Voltage

1. AC ground connection for operation below 700 MHz.

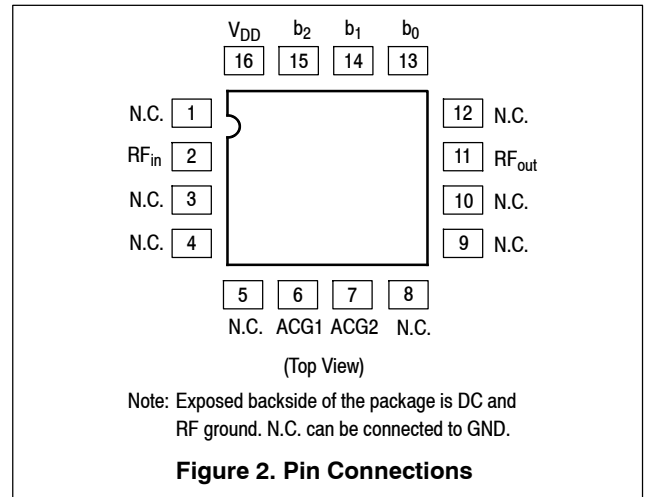

Table 8. Logic Truth Table

b ₂	b ₁	b ₀	State	Attenuation (dB)
H	H	H	111	0
L	H	H	011	1
H	L	H	101	2
L	L	H	001	3
H	H	L	110	4
L	H	L	010	5
H	L	L	100	6
L	L	L	000	7

50 OHM APPLICATION CIRCUIT: 50–4000 MHz, 5 VOLT OPERATION

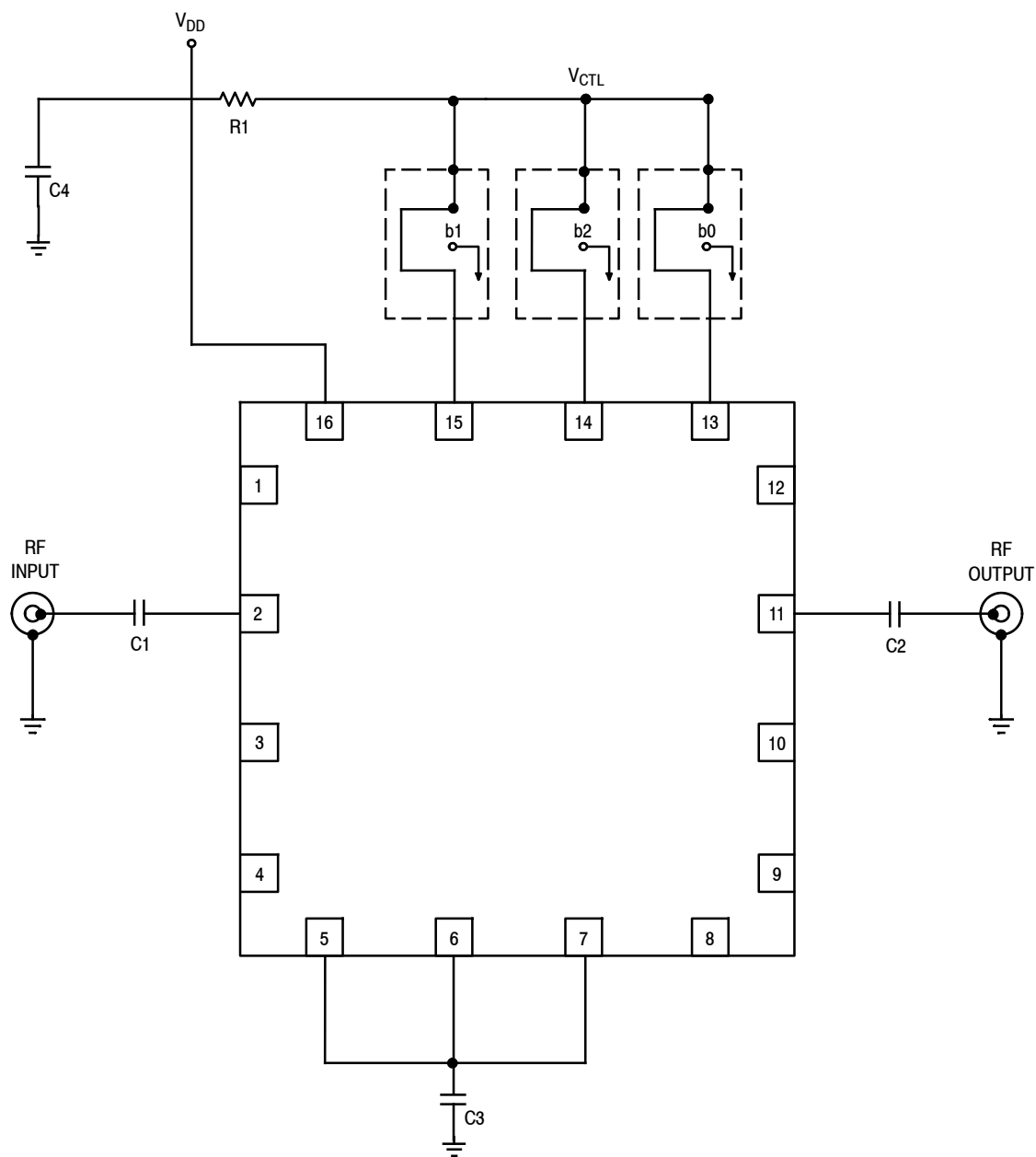
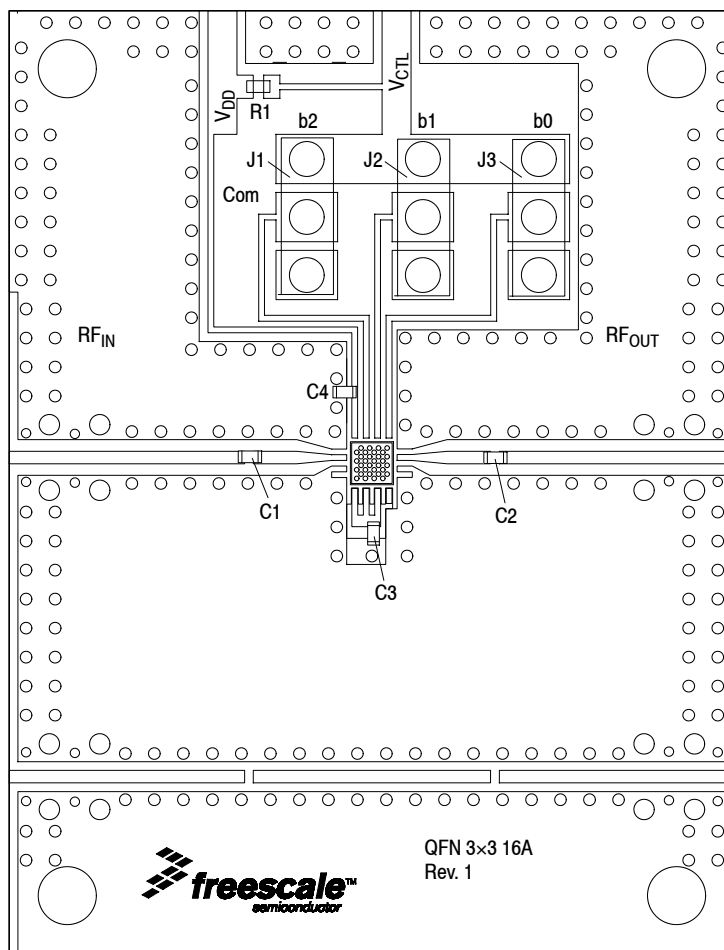

Figure 3. MMT20303HT1 Test Circuit Schematic

Table 9. MMT20303HT1 Test Circuit Component Designations and Values

Part	Description	Part Number	Manufacturer
C1, C2, C4	0.1 μ F Chip Capacitors	GRM155R61A104KA01D	Murata
C3	3300 pF Chip Capacitor	GRM1557U1A332JA01D	Murata
J1, J2, J3	3-pin Header	22-28-8360	Molex
R1	1000 Ω , 1/16 W Chip Resistor	RC0402FR-071KL	Yageo
PCB	Rogers RO4350B, 0.010", $\epsilon_r = 3.66$	M60818	MTL

50 OHM APPLICATION CIRCUIT: 50–4000 MHz, 5 VOLT OPERATION



PCB actual size: 1.25" × 1.62".

Figure 4. MMT20303HT1 Test Circuit Component Layout

Table 9. MMT20303HT1 Test Circuit Component Designations and Values

Part	Description	Part Number	Manufacturer
C1, C2, C4	0.1 μF Chip Capacitors	GRM155R61A104KA01D	Murata
C3	3300 pF Chip Capacitor	GRM1557U1A332JA01D	Murata
J1, J2, J3	3-pin Header	22-28-8360	Molex
R1	1000 Ω, 1/16 W Chip Resistor	RC0402FR-071KL	Yageo
PCB	Rogers RO4350B, 0.010", ε _r = 3.66	M60818	MTL

(Test Circuit Component Designations and Values table repeated for reference.)

50 OHM APPLICATION CIRCUIT: 50–4000 MHz, 5 VOLT OPERATION

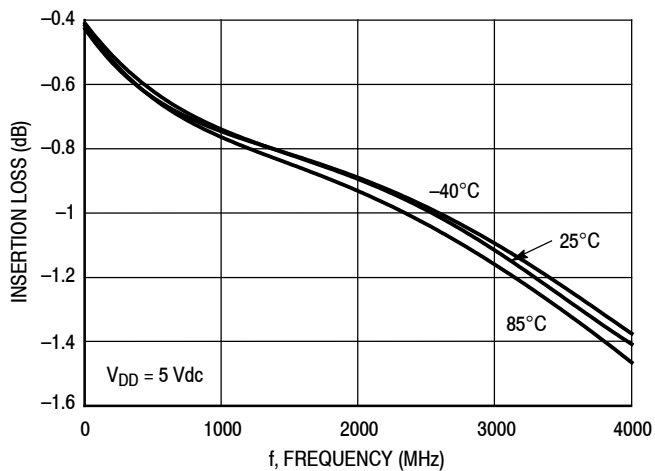

Figure 5. Insertion Loss versus Frequency versus Temperature

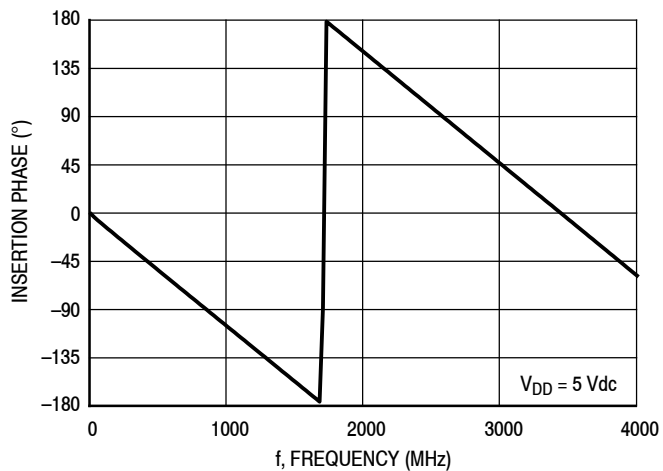

Figure 6. Insertion Phase versus Frequency versus Temperature (-40°C, 25°C, 85°C)

50 OHM APPLICATION CIRCUIT: 50–4000 MHz, 5 VOLT OPERATION

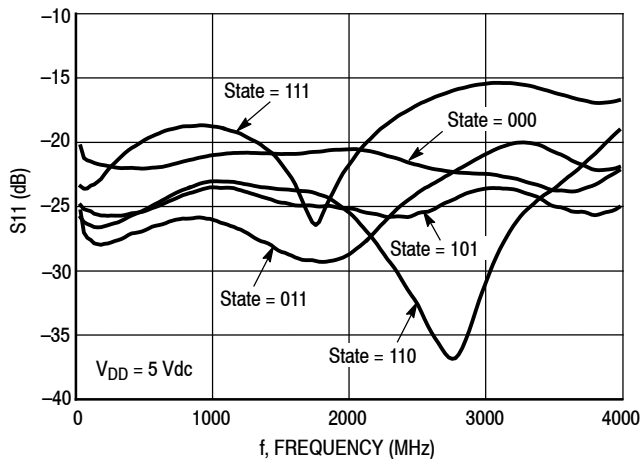

Figure 7. S11 versus Frequency

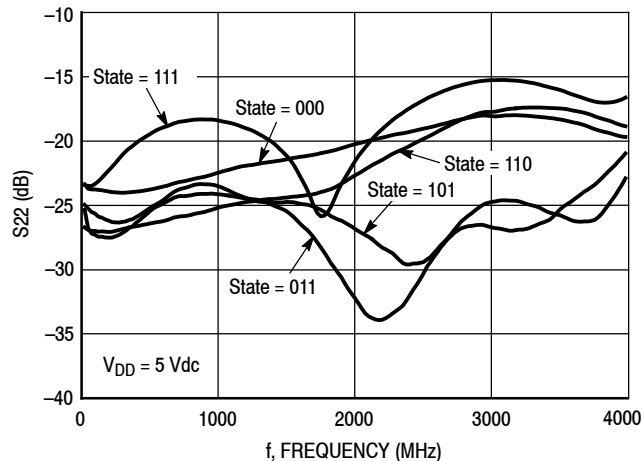
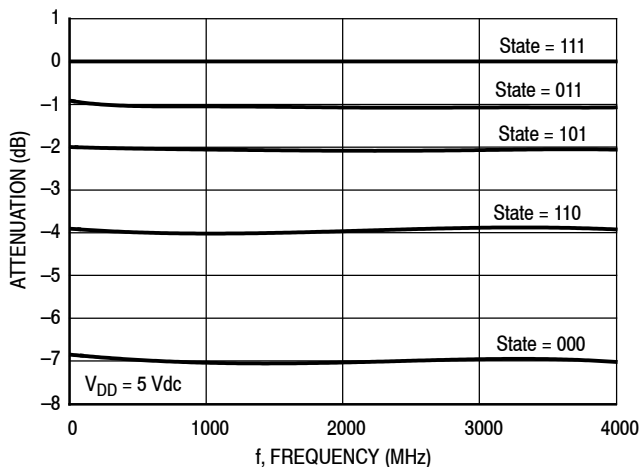

Figure 8. S22 versus Frequency



Attenuation Error Due to Temperature

Major Setting	Temperature Range	Δ Attenuation due to Temperature
0 dB	-40°C to 85°C	±0 dB
1 dB		±0.08 dB
2 dB		±0.08 dB
4 dB		±0.08 dB
7 dB		±0.20 dB

Figure 9. Attenuation versus Frequency

50 OHM APPLICATION CIRCUIT: 50–4000 MHz, 5 VOLT OPERATION

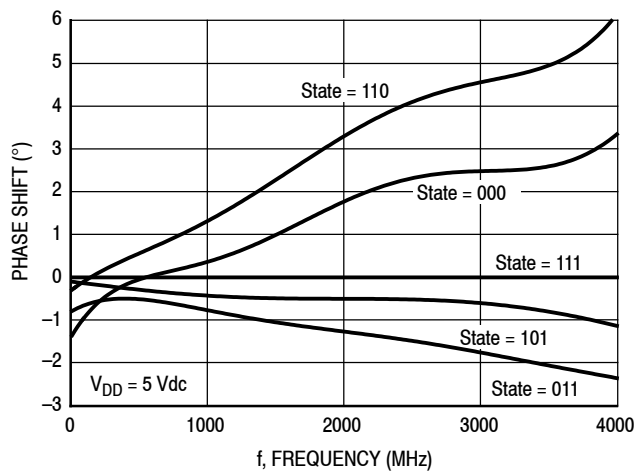

Figure 10. Phase Shift versus Frequency

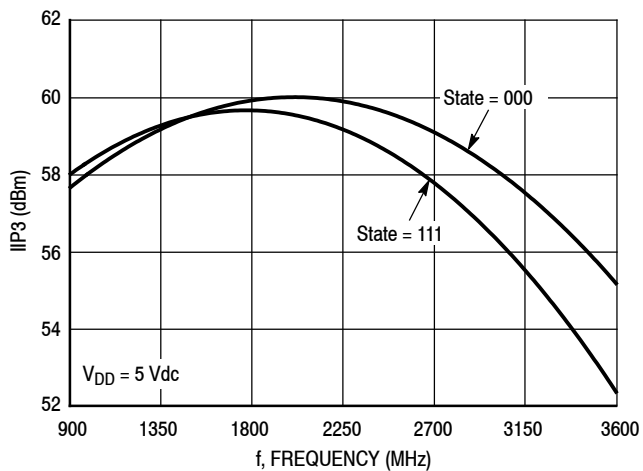

Figure 11. IIP3 versus Frequency

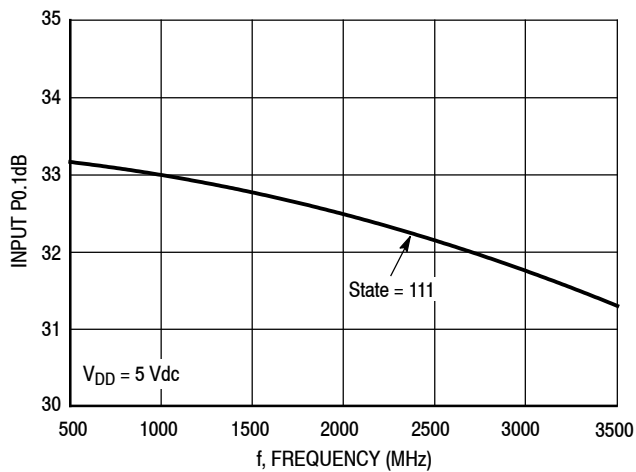

Figure 12. Input P0.1dB versus Frequency

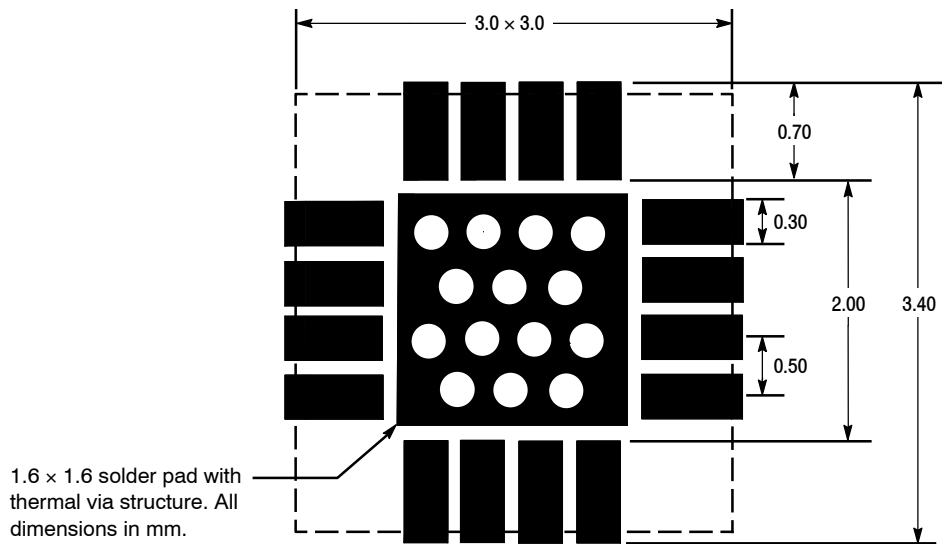

Figure 13. PCB Pad Layout for QFN 3 × 3, 16 Lead

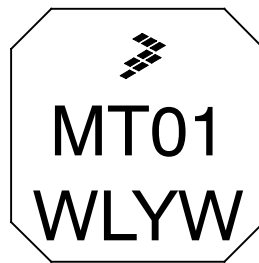
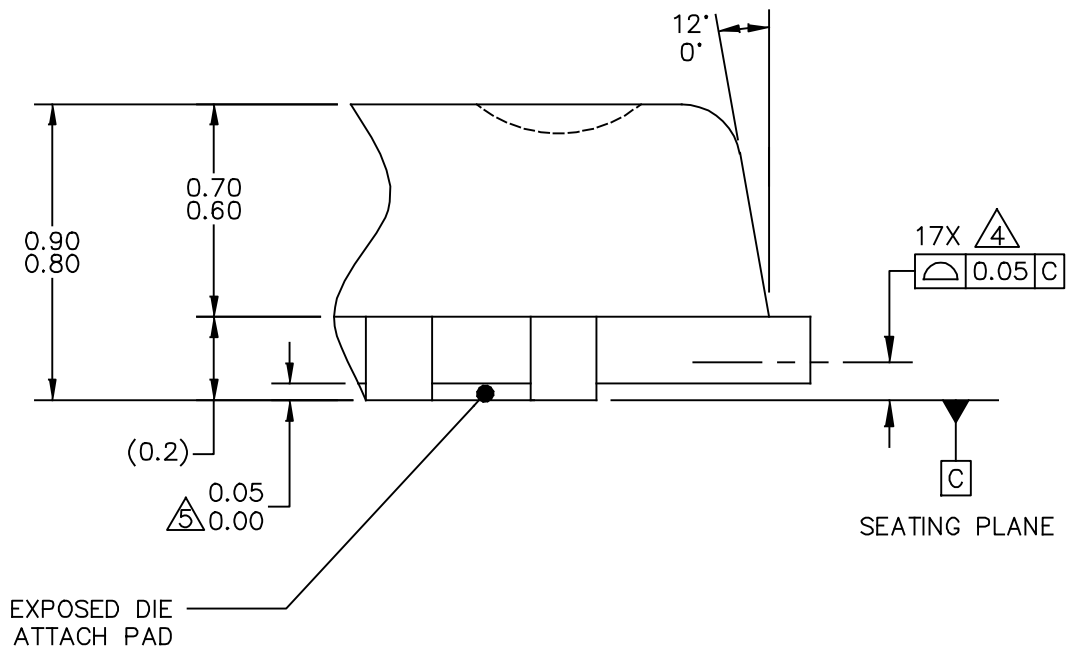

Figure 14. Product Marking



DETAIL G
VIEW ROTATED 90° CW

© FREESCALE SEMICONDUCTOR, INC. ALL RIGHTS RESERVED.	MECHANICAL OUTLINE	PRINT VERSION NOT TO SCALE	
TITLE: QFN (PUNCH), THERMALLY ENHANCED 3 X 3 X 0.85, 0.5 PITCH, 16 TERMINAL		DOCUMENT NO: 98ASA00598D	REV: 0
		STANDARD: NON-JEDEC	
			20 MAY 2013

NOTES:

1. ALL DIMENSIONS ARE IN MILLIMETERS.

2. DIMENSIONING AND TOLERANCING PER ASME Y14.5M-2009.

3. THIS DIMENSION APPLIES TO METALIZED TERMINAL AND IS MEASURED BETWEEN 0.15 AND 0.30MM FROM TERMINAL TIP.

4. BILATERAL COPLANARITY ZONE APPLIES TO THE EXPOSED PAD AS WELL AS THE TERMINALS.

5. THIS DIMENSION APPLIES ONLY FOR TERMINALS.

© FREESCALE SEMICONDUCTOR, INC. ALL RIGHTS RESERVED.	MECHANICAL OUTLINE	PRINT VERSION NOT TO SCALE	
TITLE: QFN (PUNCH), THERMALLY ENHANCED 3 X 3 X 0.85, 0.5 PITCH, 16 TERMINAL		DOCUMENT NO: 98ASA00598D	REV: 0
		STANDARD: NON-JEDEC	
		20 MAY 2013	

PRODUCT DOCUMENTATION AND TOOLS

Refer to the following resources to aid your design process.

Application Notes

- AN1955: Thermal Measurement Methodology of RF Power Amplifiers

Development Tools

- Printed Circuit Boards

To Download Resources Specific to a Given Part Number:

1. Go to <http://www.freescale.com/rf>
2. Search by part number
3. Click part number link
4. Choose the desired resource from the drop down menu

FAILURE ANALYSIS

At this time, because of the physical characteristics of the part, failure analysis is limited to electrical signature analysis. In cases where Freescale is contractually obligated to perform failure analysis (FA) services, full FA may be performed by third party vendors with moderate success. For updates contact your local Freescale Sales Office.

REVISION HISTORY

The following table summarizes revisions to this document.

Revision	Date	Description
0	Dec. 2015	<ul style="list-style-type: none">• Initial release of data sheet