

## DESCRIPTION

The MP2030 is a very low dropout, dual supply linear regulator. The use of two supplies allows the BIAS to control an NMOS device. The NMOS device supplies power to the load via the IN. In this way the input supply can be just above the desired output, yet still provide very good regulation performance due to the higher bias supply. The BIAS operates from a 2.5V to 5.5V input and regulates the output voltage to as low as 0.9V, and as high as 3.8V.

The MP2030 can supply up to 3A of load current with a typical dropout voltage of 150mV. The BIAS runs the internal reference and drive circuitry, while the output current comes directly from the IN for high efficiency regulation.

The low bias current of 220uA makes the MP2030 ideal for use in battery-powered applications. The BIAS can be directly applied from the battery while IN is powered from the high efficiency buck regulator. This will reduce the output noise and decoupling capacitor.

Other features of MP2030 include thermal overload and current limit protection, power good indicator, stability with ultra low ESR ceramic capacitors as low as 1uF, and fast transient response. The MP2030 is available in 10-pin QFN (3mm x 3mm), and in QFN (5mm x 5mm) packages.

## FEATURES

- Wide 1.1V to 5.5V Input Voltage Range
- Stable with Very Small Ceramic Capacitors
- 150mV Dropout at 3A Output
- 2% Accurate Output Voltage
- Adjustable Output Range of 0.9V to 3.8V
- Low Noise: 80 $\mu$ V<sub>RMS</sub> (10Hz to 100kHz)
- PSRR
  - 32dB at 100kHz
- Better Than 0.001%/mA Load Regulation
- Stable With Low-ESR Output Capacitors
- Low 220uA Ground Current
- Internal Thermal Protection
- Current Limit Protection
- 0.1 $\mu$ A Typical Quiescent Current at Shutdown
- Power Good Indicator

## APPLICATIONS

- Network, Telecom, Equipment: Routers and Switches
- Servers, Storage Equipment
- Set-Top Box
- Post Regulation for Switch Mode
- Televisions

"MPS" and "The Future of Analog IC Technology" are Registered Trademarks of Monolithic Power Systems, Inc.

## TYPICAL APPLICATION

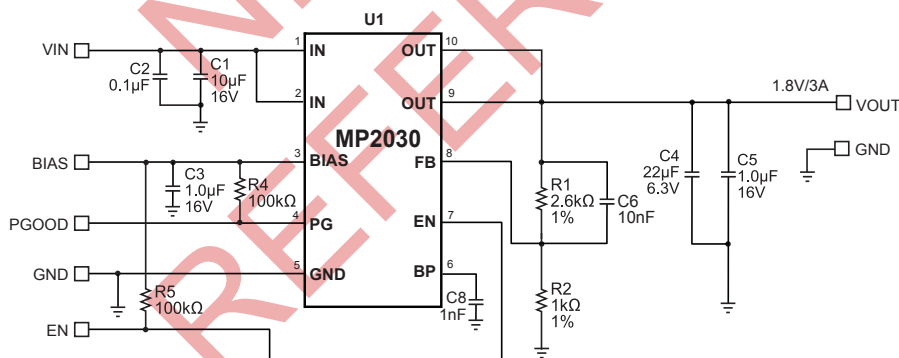

### ORDERING INFORMATION

| Part Number* | Package   | Top Marking | Free Air Temperature (T <sub>A</sub> ) |
|--------------|-----------|-------------|--|
| MP2030DQ*    | 3x3 QFN10 | 7D          | -40°C to +85°C                         |
| MP2030DU**   | 5x5 QFN32 | M2030DU     | -40°C to +85°C                         |

\* For Tape & Reel, add suffix -Z (eg. MP2030DQ-Z).  
For RoHS compliant packaging, add suffix -LF (eg. MP2030DQ-LF-Z)

\*\* For Tape & Reel, add suffix -Z (eg. MP2030DU-Z).  
For RoHS compliant packaging, add suffix -LF (eg. MP2030DU-LF-Z)

### PACKAGE REFERENCE

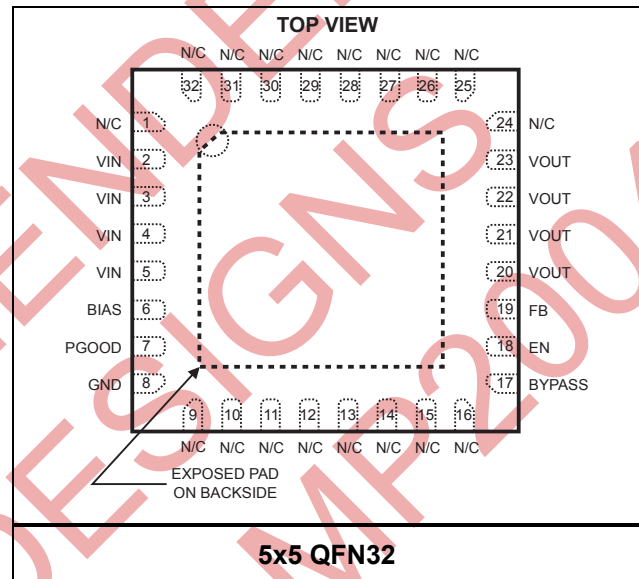
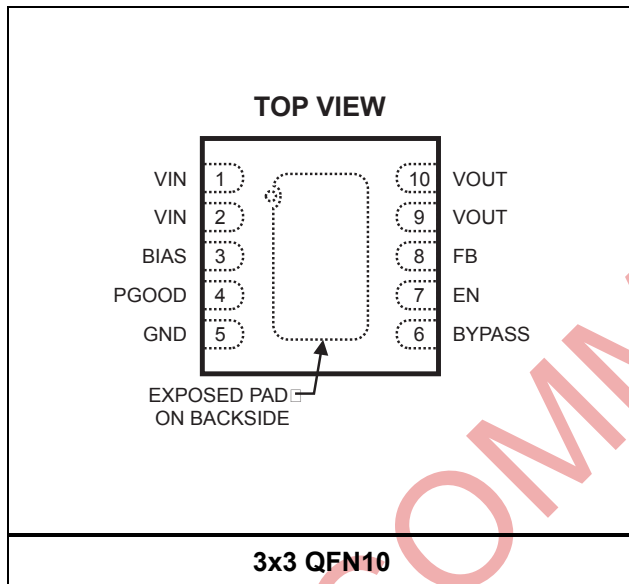

#### ABSOLUTE MAXIMUM RATINGS <sup>(1)</sup>

|  |  |
|--|--|
| V <sub>BIAS</sub> , V <sub>IN</sub> to GND | -0.3V to +6V                           |
| FB, EN, to GND                             | -0.3V to 6V                            |
| V <sub>OUT</sub>                           | -0.3V to V <sub>IN</sub> + 0.3 or 6V   |
| PGOOD                                      | -0.3V to V <sub>BIAS</sub> + 0.3 or 6V |
| BYPASS                                     | -0.3V to V <sub>BIAS</sub> + 0.3 or 6V |
| Junction Temperature                       | 150°C                                  |
| Lead Temperature                           | 260°C                                  |
| Storage Temperature                        | -65°C to +150°C                        |

#### Power Dissipation

|                                    |      |
|------------------------------------|------|
| T <sub>A</sub> =70°C (QFN10 3 x 3) | 1.3W |
| T <sub>A</sub> =70°C (QFN32 5 x 5) | 1.8W |

#### Recommended Operating Conditions <sup>(2)</sup>

|                                 |                 |
|---------------------------------|-----------------|
| Input Voltage V <sub>IN</sub>   | 1.1V to 5.5V    |
| Input Voltage V <sub>BIAS</sub> | 2.5V to 5.5V    |
| Output Voltage                  | 0.9V to 3.6V    |
| Load Current                    | 3.0A Maximum    |
| Operating Junct. Temp.          | -40°C to +125°C |

#### Thermal Resistance <sup>(3)</sup>

|           | θ <sub>JA</sub> | θ <sub>JC</sub> |
|-----------|-----------------|-----------------|
| QFN10 3X3 | 50              | 12 °C/W         |
| QFN32 5X5 | 36              | 8 °C/W          |

#### Notes:

- Exceeding these ratings may damage the device.
- The device is not guaranteed to function outside of its operating conditions.
- Measured on JESD51-7, 4-layer PCB.

**ELECTRICAL CHARACTERISTICS**
 $V_{IN} = 1.5V$ ,  $V_{BIAS} = 3.6V$ ,  $V_{OUT} = 1.2V$ ,  $C_{OUT} = 1\mu F$ ,  $C_{IN} = 0.1\mu F$ ,  $T_A = +25^\circ C$ , unless otherwise noted.

| Parameter                     | Symbol | Condition   | Min   | Typ   | Max   | Units      |
|-------------------------------|--------|---|-------|-------|-------|------------|
| $V_{IN}$ Operating Voltage    |        |   | 1.1   |       | 5.5   | V          |
| $V_{BIAS}$ Operating Voltage  |        |   | 2.5   |       | 5.5   | V          |
| $V_{BIAS}$ Operating Current  |        |   |       | 220   |       | $\mu A$    |
| FB Regulation Voltage         |        |   | 0.490 | 0.500 | 0.510 | V          |
|                               |        | $-40^\circ C \leq T_A \leq +85^\circ C$   | 0.485 | 0.500 | 0.515 |            |
| Dropout Voltage               |        | $I_{OUT} = 3A$ , $V_{BIAS} = 3.6V$  |       | 150   |       | mV         |
| $V_{IN}$ Line Regulation      |        | $I_{OUT} = 1mA$ ,<br>$V_{IN} = 1.5$ to $5V$<br>$V_{BIAS} = 3.6V$ $V_{OUT} = 1.2V$                             |       | 1     |       | mV         |
| $V_{BIAS}$ Line Regulation    |        | $I_{OUT} = 1mA$ ,<br>$V_{BIAS} = 3.6V$ to $5.5V$ $V_{OUT} = 1.2V$<br>$V_{IN} = 1.5V$                          |       | 2     |       | mV         |
| Load Regulation               |        | $I_{OUT} = 1mA$ to $1A$   |       | 0.001 |       | %/mA       |
| PSRR<br>( $V_{IN}$ )          |        | $V_{IN} > V_{OUT} + 0.5V$ , $C_{OUT} = 22\mu F$ ,<br>$V_{IN(AC)} = 100mV$ , $f = 100KHz$<br>$I_{OUT} = 300mA$ |       | 32    |       | dB         |
| Power Good Threshold          |        |   |       | 440   |       | mV         |
| Power Good Delay              |        |   |       | 160   |       | $\mu s$    |
| Soft Start                    |        | BYPASS=open   |       | 550   |       | $\mu s$    |
| Power Good Voltage            |        | $I_{sink} = 230\mu A$   |       | 0.39  |       | V          |
| EN Input High Voltage         |        |   | 1.5   |       |       | V          |
| EN Input Low Voltage          |        |   |       |       | 0.8   | V          |
| EN Input Bias Current         |        | $V_{EN} = 1.2V$   | -1    |       | +1    | $\mu A$    |
| Thermal Protection            |        |   |       | 135   |       | $^\circ C$ |
| Thermal Protection Hysteresis |        |   |       | 15    |       | $^\circ C$ |

## PIN FUNCTIONS

### QFN3X3 10pins

| Pin # | Name   | Description   |
|-------|--------|---|
| 9, 10 | OUT    | Regulator Output. OUT is the output of the linear regulator, By pass OUT to GND with a 4.7 $\mu$ F or greater capacitor.                                      |
| 3     | BIAS   | Bias Voltage. Bypass to ground with a 1 $\mu$ F or greater capacitor for maximum output current the $V_{IN} > 0.2V + V_{OUT}$ and $V_{BIAS} > 2V + V_{OUT}$ . |
| 8     | FB     | Feedback Input. Connect a resistive voltage divider from OUT to FB to set the output voltage. OUT feedback threshold is 0.5V.                                 |
| 7     | EN     | Enable Input. Drive EN high to turn on the MP2030, drive EN low to turn it off. For automatic startup, connect EN to IN.                                      |
| 5     | GND    | Ground, exposed pad.  |
| 1, 2  | IN     | Power Source Input. IN supplies power to the load at the output (through the power transistor). Bypass IN to GND with a 1 $\mu$ F or greater capacitor.       |
| 4     | PGOOD  | Open drain output. High indicated $V_{OUT} > 90\%$ final value.   |
| 6     | BYPASS | Connect a 1nF to this pin. Do not load this pin resistively.  |

### QFN5x5 32pins

| Pin #  | Name   | Description   |
|--|--------|---|
| 20, 21, 22, 23   | VOUT   | Regulator Output. OUT is the output of the linear regulator, By pass OUT to GND with a 4.7 $\mu$ F or greater capacitor.                                |
| 6  | BIAS   | Bias Voltage. Bypass to ground with a 1 $\mu$ F or greater capacitor.   |
| 19   | FB     | Feedback Input. Connect a resistive voltage divider from OUT to FB to set the output voltage. OUT feedback threshold is 0.5V.                           |
| 18   | EN     | Enable Input. Drive EN high to turn on the MP2030, drive EN low to turn it off. For automatic startup, connect EN to IN.                                |
| 8  | GND    | Ground, exposed pad.  |
| 2, 3, 4, 5   | VIN    | Power Source Input. IN supplies power to the load at the output (through the power transistor). Bypass IN to GND with a 1 $\mu$ F or greater capacitor. |
| 7  | PGOOD  | Open drain output. High indicated $V_{OUT} > 90\%$ final value.   |
| 17   | BYPASS | Connect a 1nF to this pin. Do not load this pin resistively.  |
| 1, 9, 10, 11, 12, 13, 14, 15, 16, 24, 25, 26, 27, 28, 29, 30, 31, 32 | NC     | These are no connection pins.   |

TYPICAL PERFORMANCE CHARACTERISTICS

C1=10μF, C2=0.1μF, C3=1.0μF, C4=22μF, C6=22nF, V<sub>B</sub>=5.5V, T<sub>A</sub>=25°C, unless otherwise noted

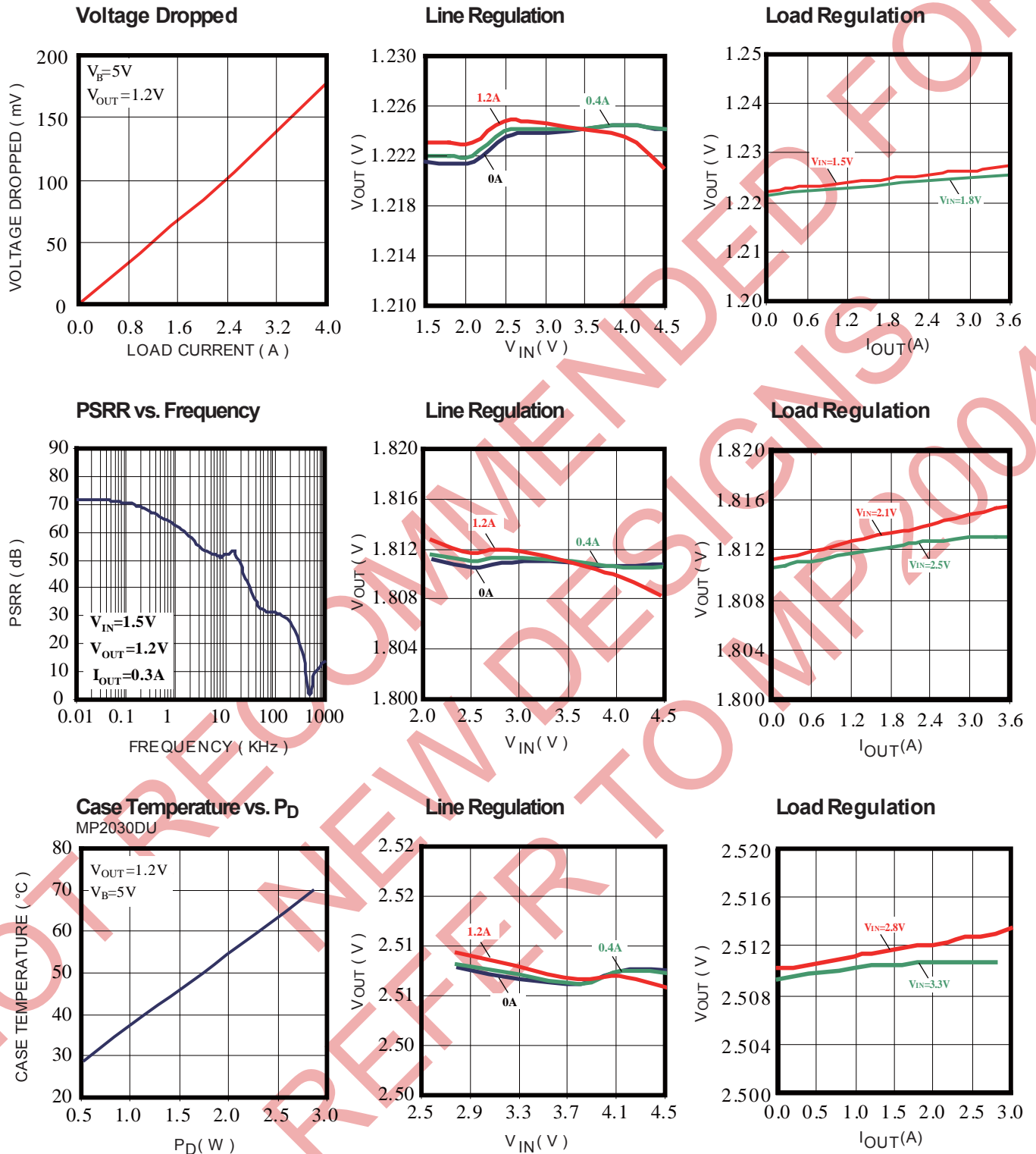

TYPICAL PERFORMANCE CHARACTERISTICS

C1=10μF, C2=0.1μF, C3=1.0μF, C4=22μF, C6=22nF, V<sub>B</sub>=5.5V, T<sub>A</sub>=25°C, unless otherwise noted

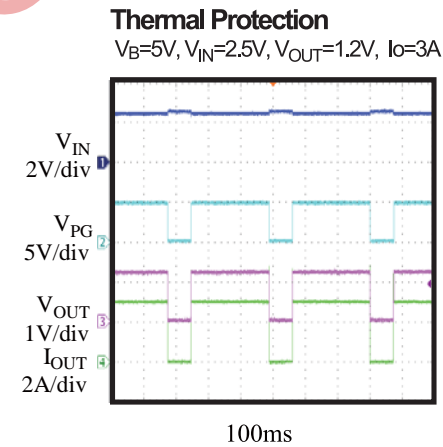
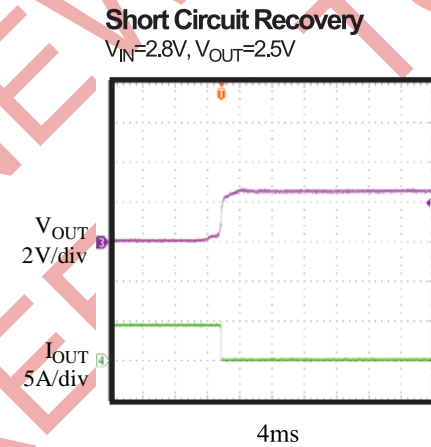
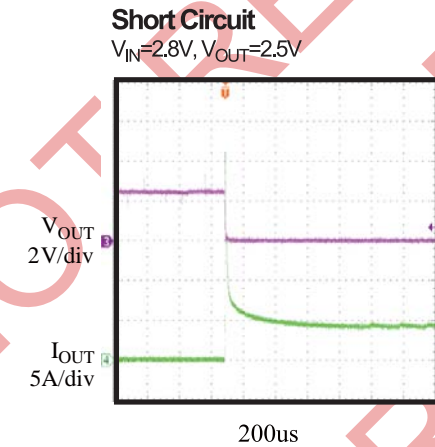
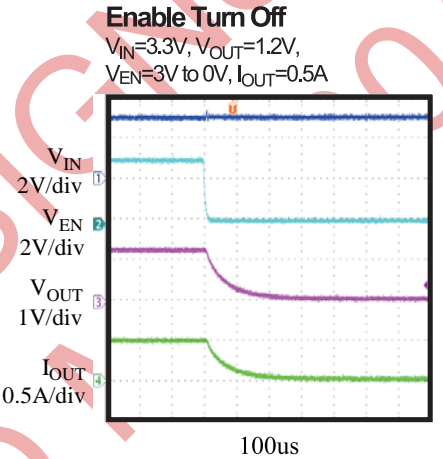
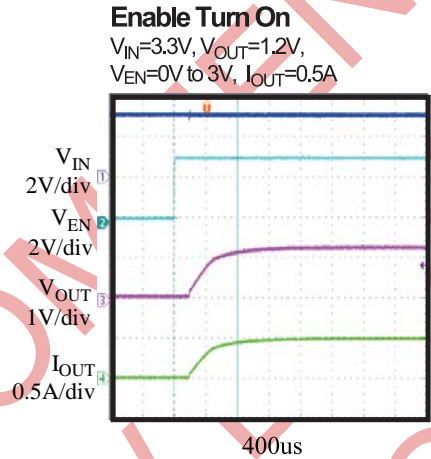
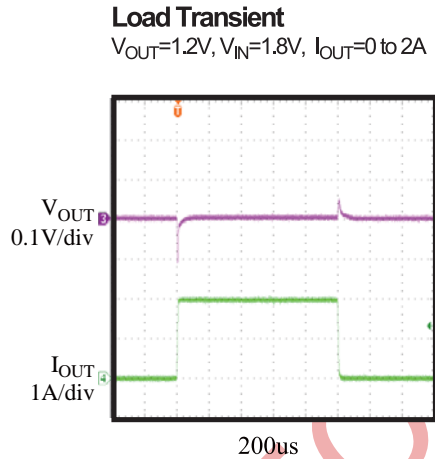
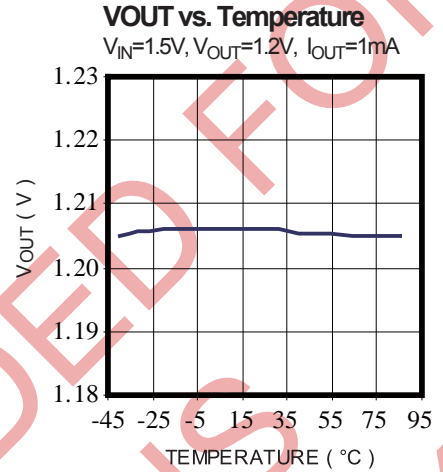
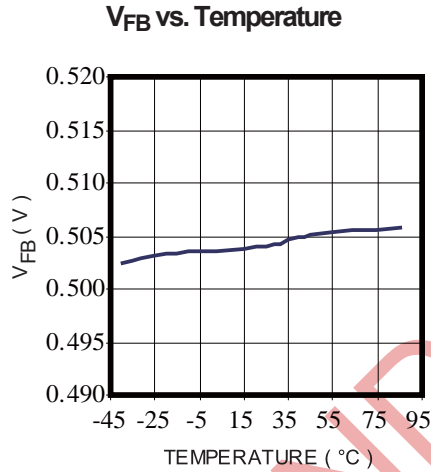
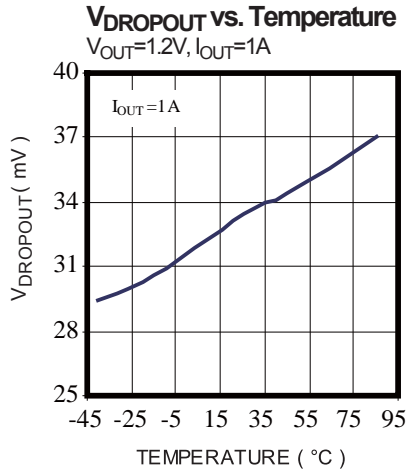

**TYPICAL PERFORMANCE CHARACTERISTICS**

C1=10μF, C2=0.1μF, C3=1.0μF, C4=22μF, C6=22nF, V<sub>B</sub>=5.5V, T<sub>A</sub>=25°C, unless otherwise noted

**Power Ramp Up**

V<sub>IN</sub>=2.1V, V<sub>OUT</sub>=1.8V, I<sub>OUT</sub>=3A, with Resistor load

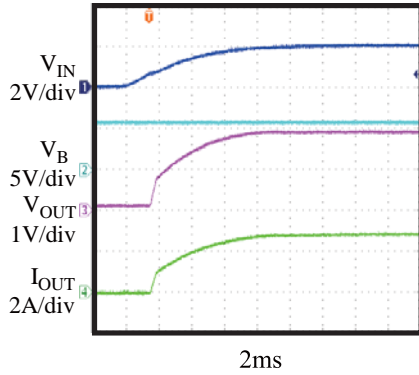

**Power Ramp Down**

V<sub>IN</sub>=2.1V, V<sub>OUT</sub>=1.8V, I<sub>OUT</sub>=3A, with Resistor load

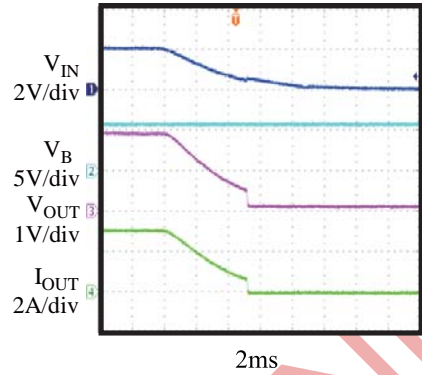

**Line Transient**

V<sub>IN</sub>=1.8 to 5V, V<sub>OUT</sub>=1.2V, I<sub>OUT</sub>=0.2A,

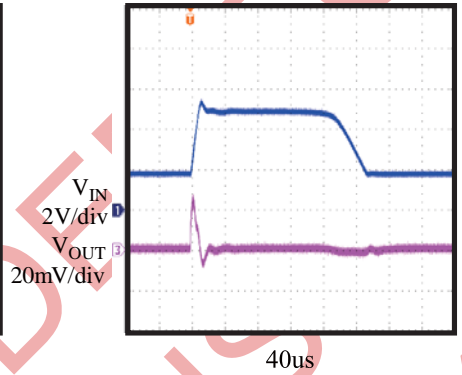

NOT RECOMMENDED FOR NEW DESIGNERS REFER TO MP20046



BLOCK DIAGRAM

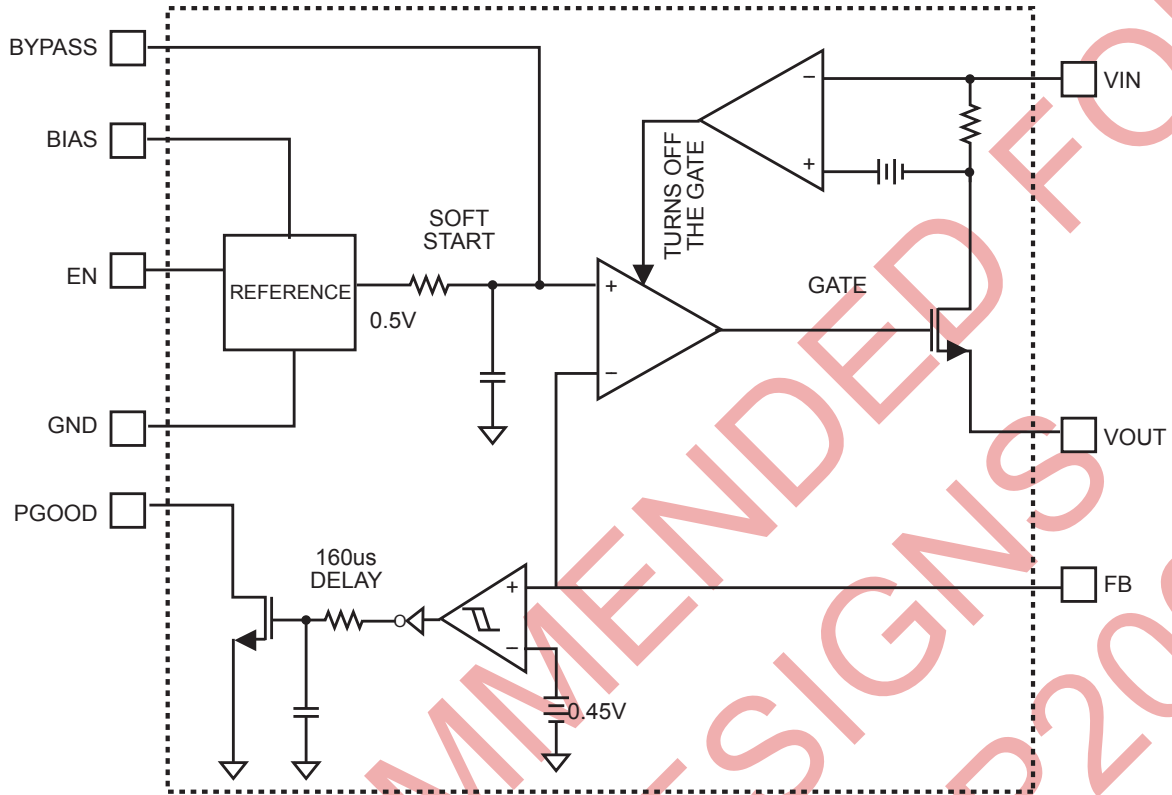

Figure 1—Block Diagram of Low Dropout Regulator



## OPERATION

### MP2030 Theory of Operation

The MP2030 linear dropout regulator provides adjustable output voltages from 0.9V to 3.6V at currents up to 3A. This LDO is protected against short circuits, and it has thermal shut down protection with 15°C hysteresis.

### Utilizing Two Power Supplies

In order to maximize the efficiency MP2030 uses two power supplies. One power supply is connected to the BIAS pin and it is used to power up the internal circuitries including band gap reference and the rest of control circuitries. The other power supply is connected to the VIN pins which are the drain of pass device. This power supply can be set close to output voltage of LDO. The output pins are the source of the pass device. The smaller voltage drop across the pass device translates to the smaller power loss in pass device. Thus, the part operates with higher efficiency.

### Internal Current Limit

The MP2030 has an internal current limit set at almost 4.5A. When the output current is greater than 4.5A, current limit is activated, the output voltage is internally forced close to ground, and stays at this voltage until the short circuit is removed. Internal current limit is very well controlled over process variations and ambient temperature.

### Enable

The enable (EN) pin is active high. The enable pin has a built-in hysteresis. If this pin is held below 0.8V then part shuts down and draws less than 1uA from  $V_{BIAS}$  supply.

If not used then connect this pin to  $V_{BIAS}$ .

### Under Voltage Lockout

The Bias voltage is monitored by a circuit that prevents the LDO start up when the bias voltage is below 2.35V. This circuitry has an approximate hysteresis of 90mV.

### Soft Start

MP2030 incorporates internal soft start function. This internal function reduces the start up current surge into the output capacitor. This allows the gradual built up of output voltage to its final set value. The internal soft start cap is held to ground if there is a fault condition. The fault conditions are UVLO, Thermal shut down, and disable. The internal soft start time is almost 550us.

### Power Good

The Power Good pin is an open drain output and can be connected to Bias voltage via a pull up resistor. Open drain transistor turns off and PG pin voltage value becomes  $V_{BIAS}$  when  $V_{FB}$  exceeds 450mV. Also PG pin can sink at least 230μA while being low.

### Setting the Output Voltage

The MP2030 has an adjustable output voltage, set by using a resistive voltage divider from the output voltage to FB pin. The voltage divider divides the output voltage down to the feedback voltage by the ratio:

$$V_{FB} = V_{OUT} * R_2 / (R_1 + R_2)$$

Where  $V_{FB}$  is the feedback threshold voltage ( $V_{FB}=0.5V$ ), and  $V_{OUT}$  is the output voltage.  $R_1$  connects between  $V_{OUT}$  and  $V_{FB}$ , and  $R_2$  connects between  $V_{FB}$  and ground.

Thus the output voltage is:

$$V_{OUT} = 0.5 * (R_1 + R_2) / R_2$$

$R_2$  can be as high as 100KΩ, but a typical value is 10KΩ. Using that value,  $R_1$  is determined by:

$$R_1 = R_2 * (V_{OUT} - V_{FB}) / V_{FB}$$

For example, for a 1.8V output voltage,  $R_2$  is 10KΩ, and  $R_1$  is 26kΩ. You can select 26kΩ (1%) resistor for  $R_1$ .

### Power Dissipation

Most of the power dissipation is due to power dissipation in PASS device. For example, assume  $V_{BIAS}=5.0V$ ,  $V_{IN}=2.0V$ ,  $V_{OUT}=1.8V$ , and  $I_{OUT}=3A$ :

$$P_D (PASS) = (V_{IN} - V_{OUT}) * I_{OUT}$$

$$P_D (PASS) = (2.0V - 1.8V) * 3A = 0.6$$

$P_{BIAS} = V_{BIAS} \times I_{GND} = 5V \times (220\mu A) = 1.25mW$ .  
This is negligible compared to  $P_D (PASS) = 0.6W$

For QFN 3X3  $\theta_{JA}$  is  $50^\circ C/W$ .

0.6W power is dissipated when 3A output current goes through PASS device with  $V_{IN}=2.0V$ , and  $V_{OUT}=1.8V$ .

This gives a rise in die temperature for  $0.6 \times 50^\circ C/W = 30^\circ C$

This is a safe operating point assuming a junction temperature of  $135^\circ C$  at an  $85^\circ C$  ambient temperature.

A heat sink needs to be utilized for a better temperature performance.

NOT RECOMMENDED FOR  
NEW DESIGNS  
REFER TO MP20046

PACKAGE INFORMATION

QFN10 (3mm x 3mm)

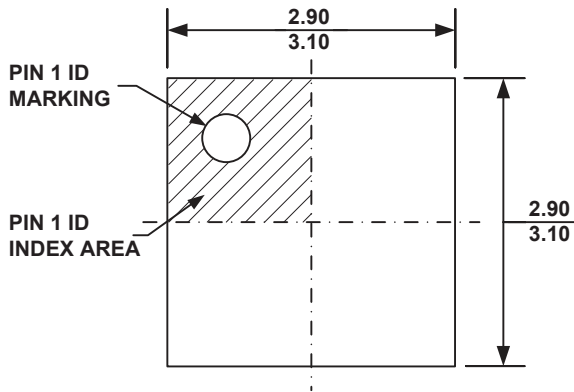

TOP VIEW

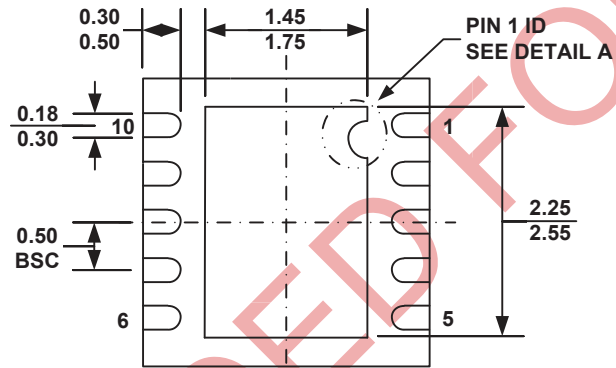

BOTTOM VIEW

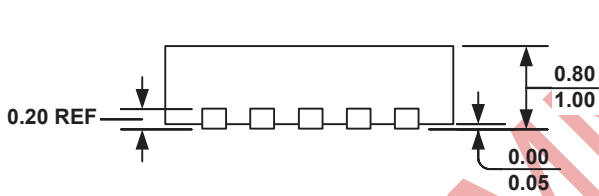

SIDE VIEW

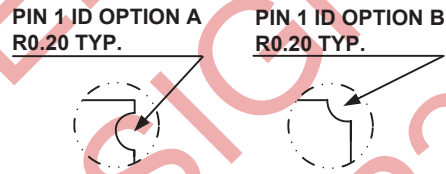

DETAIL A

NOTE:

- 1) ALL DIMENSIONS ARE IN MILLIMETERS.
- 2) EXPOSED PADDLE SIZE DOES NOT INCLUDE MOLD FLASH.
- 3) LEAD COPLANARITY SHALL BE 0.10 MILLIMETER MAX.
- 4) DRAWING CONFORMS TO JEDEC MO-229, VARIATION VEED-5.
- 5) DRAWING IS NOT TO SCALE.

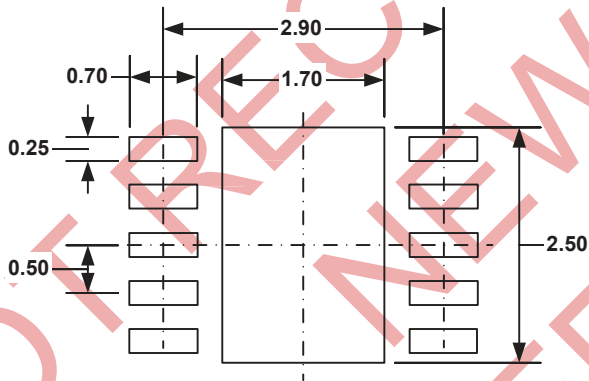

RECOMMENDED LAND PATTERN