



The Future of Analog IC Technology®

# MP2355

## 3A, 23V, 380KHz Step-Down Converter

### DESCRIPTION

The MP2355 is a step-down regulator with a built in internal Power MOSFET. It achieves 3A continuous output current over a wide input supply range with excellent load and line regulation.

Current mode operation provides fast transient response and eases loop stabilization. Fault condition protection includes cycle-by-cycle current limiting and thermal shutdown. Adjustable soft-start reduces the stress on the input source at turn-on. In shutdown mode the regulator draws 20µA of supply current.

The MP2355 uses a minimum number of readily available external components to complete a 3A step-down DC to DC converter solution.

### EVALUATION BOARD REFERENCE

Board Number	Dimensions
EV2355DN-00A	2.0"X x 1.3"Y x 0.5"Z

### FEATURES

- Programmable Soft-Start
- 100mΩ Internal Power MOSFET Switch
- Stable with Low ESR Output Ceramic Capacitors
- Up to 95% Efficiency
- 20µA Shutdown Mode
- 3A Output Current
- Wide 4.75V to 23V Operating Input Range
- Fixed 380KHz Frequency
- Thermal Shutdown
- Cycle-by-Cycle Over Current Protection
- Under Voltage Lockout

### APPLICATIONS

- Distributed Power Systems
- Battery Chargers
- Pre-Regulator for Linear Regulators

"MPS" and "The Future of Analog IC Technology" are Registered Trademarks of Monolithic Power Systems, Inc.

### TYPICAL APPLICATION

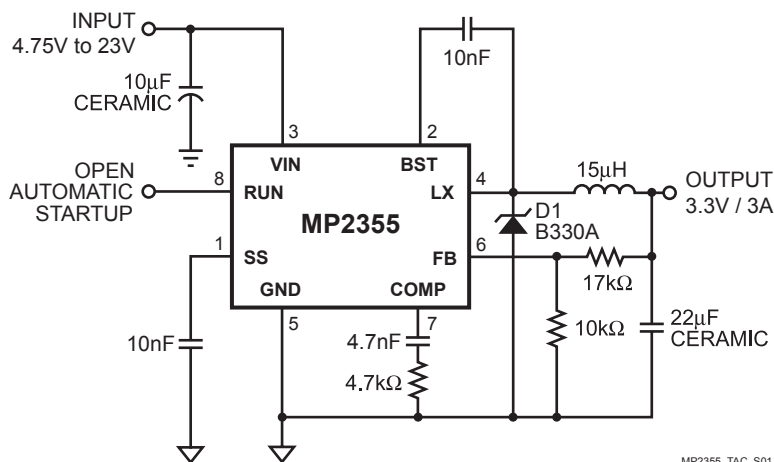

MP2355\_TAC\_S01

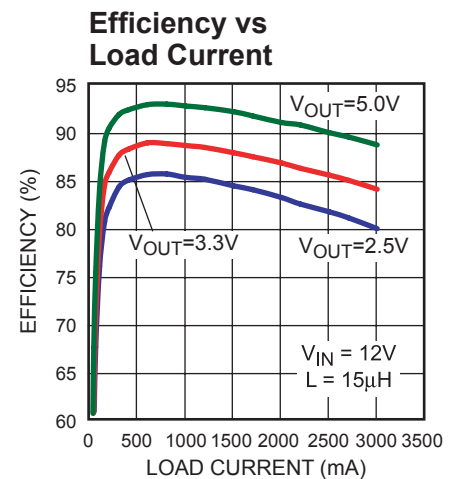

MP2355\_EC01

## PACKAGE REFERENCE

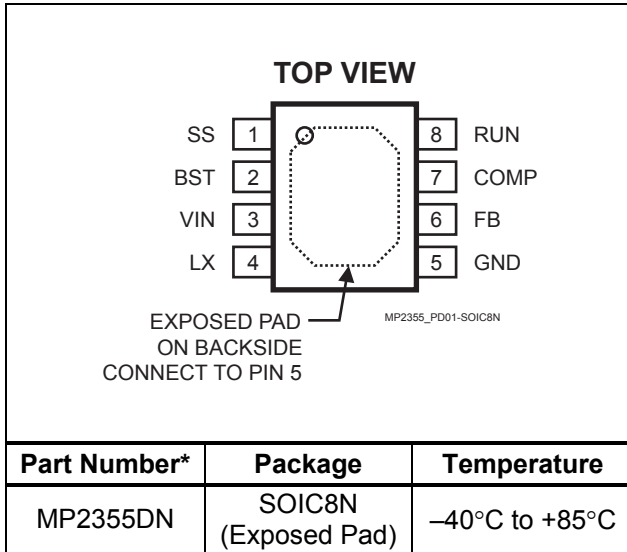

\* For Tape & Reel, add suffix -Z (eg. MP2355DN-Z)  
 For RoHS compliant packaging, add suffix -LF (eg. MP2355DN-LF-Z)

## ABSOLUTE MAXIMUM RATINGS <sup>(1)</sup>

Supply Voltage  $V_{IN}$ ..... -0.3V to +25V  
 Switch Voltage  $V_{LX}$ ..... -0.3V to +26V  
 Boost Voltage  $V_{BST}$  .....  $V_{LX} - 0.3V$  to  $V_{LX} + 6V$   
 All Other Pins..... -0.3V to +6V  
 Junction Temperature..... 150°C  
 Lead Temperature ..... 260°C  
 Storage Temperature ..... -65°C to +150°C

## Recommended Operating Conditions <sup>(2)</sup>

Input Voltage  $V_{IN}$ ..... 4.75V to 23V  
 Operating Temperature ..... -40°C to +85°C

**Thermal Resistance <sup>(3)</sup>**       $\theta_{JA}$        $\theta_{JC}$   
 SOIC8N ..... 50 ..... 10... °C/W

### Notes:

- 1) Exceeding these ratings may damage the device.
- 2) The device is not guaranteed to function outside of its operating conditions.
- 3) Measured on approximately 1" square of 1 oz copper.

## ELECTRICAL CHARACTERISTICS

$V_{IN} = 12V$ ,  $T_A = +25^\circ C$ , unless otherwise noted.

Parameter	Symbol	Condition	Min	Typ	Max	Units
Shutdown Supply Current		$V_{RUN} = 0V$		20	30	$\mu A$
Supply Current		$V_{RUN} = 2.8$ , $V_{FB} = 1.5V$		1.0	1.2	mA
Feedback Voltage	$V_{FB}$	$4.75V \leq V_{IN} \leq 23V$ , $V_{COMP} < 2V$	1.194	1.222	1.250	V
Error Amplifier Voltage Gain	$A_{VEA}$			400		V/V
Error Amplifier Transconductance	$G_{EA}$	$\Delta I_{COMP} = \pm 10\mu A$	500	800	1120	$\mu A/V$
High-Side Switch-On Resistance	$R_{DS(ON)1}$			95		m $\Omega$
Low-Side Switch-On Resistance	$R_{DS(ON)2}$			10		$\Omega$
High-Side Switch Leakage Current		$V_{RUN} = 0V$ , $V_{LX} = 0V$		0	10	$\mu A$
Current Limit <sup>(4)</sup>			3.7	4.3		A
Current Sense to COMP Transconductance	$G_{CS}$			3.8		A/V
Oscillation Frequency	$f_s$		330	380	430	KHz
Short Circuit Oscillation Frequency		$V_{FB} = 0V$	20	35	50	KHz
Maximum Duty Cycle	$D_{MAX}$	$V_{FB} = 1.0V$		90		%
Minimum Duty Cycle	$D_{MIN}$	$V_{FB} = 1.5V$			0	%
EN Shutdown Threshold Voltage			0.9	1.2	1.5	V

**ELECTRICAL CHARACTERISTICS (continued)**
 $V_{IN} = 12V$ ,  $T_A = +25^{\circ}C$ , unless otherwise noted.

Parameter	Symbol	Condition	Min	Typ	Max	Units
Enable Pull Up Current		$V_{RUN} = 0V$	1.1	1.8	2.5	$\mu A$
EN UVLO Threshold		$V_{EN}$ Rising	2.37	2.54	2.71	V
EN UVLO Threshold Hysteresis				210		mV
Soft-Start Period		$C_{SS} = 0.1\mu F$		10		ms
Thermal Shutdown				150		$^{\circ}C$

**Note:**

- 4) Equivalent output current =  $1.5A \geq 50\%$  Duty Cycle  
 $2.0A \leq 50\%$  Duty Cycle  
 Assumes ripple current = 30% of load current.  
 Slope compensation changes current limit above 40% duty cycle.

**TYPICAL PERFORMANCE CHARACTERISTICS**

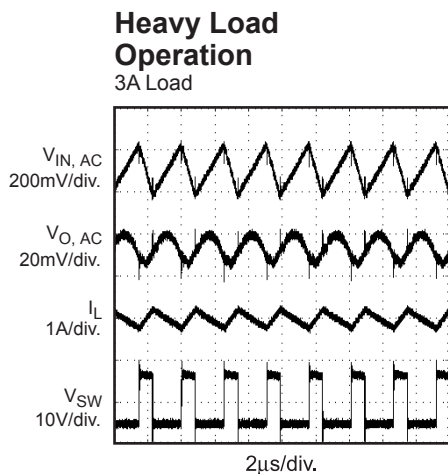
 Circuit of Figure 2,  $V_{IN} = 12V$ ,  $V_O = 3.3V$ ,  $L1 = 15\mu H$ ,  $C1 = 10\mu F$ ,  $C2 = 22\mu F$ ,  $T_A = +25^{\circ}C$ , unless otherwise noted.

MP2355-TPC01

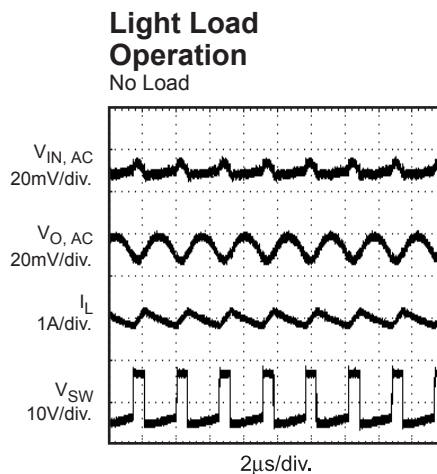

MP2355-TPC02

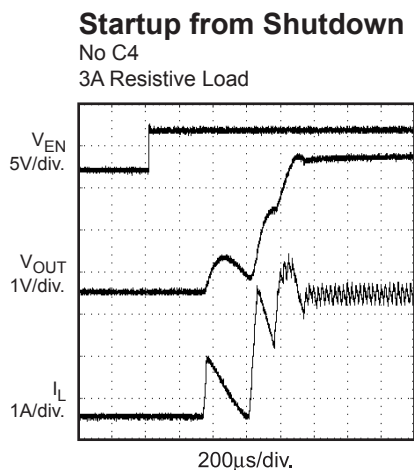

MP2355-TPC03

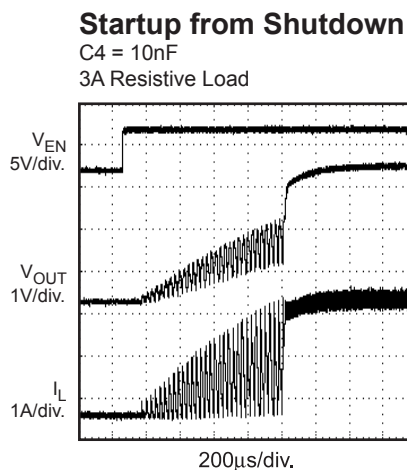

MP2355-TPC04

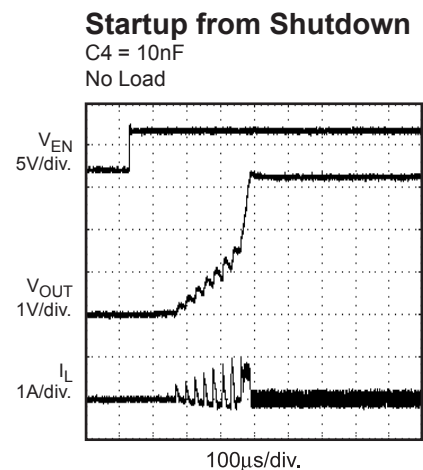

MP2355-TPC05

**TYPICAL PERFORMANCE CHARACTERISTICS (continued)**

Circuit of Figure 2,  $V_{IN} = 12V$ ,  $V_O = 3.3V$ ,  $L1 = 15\mu H$ ,  $C1 = 10\mu F$ ,  $C2 = 22\mu F$ ,  $T_A = +25^\circ C$ , unless otherwise noted.

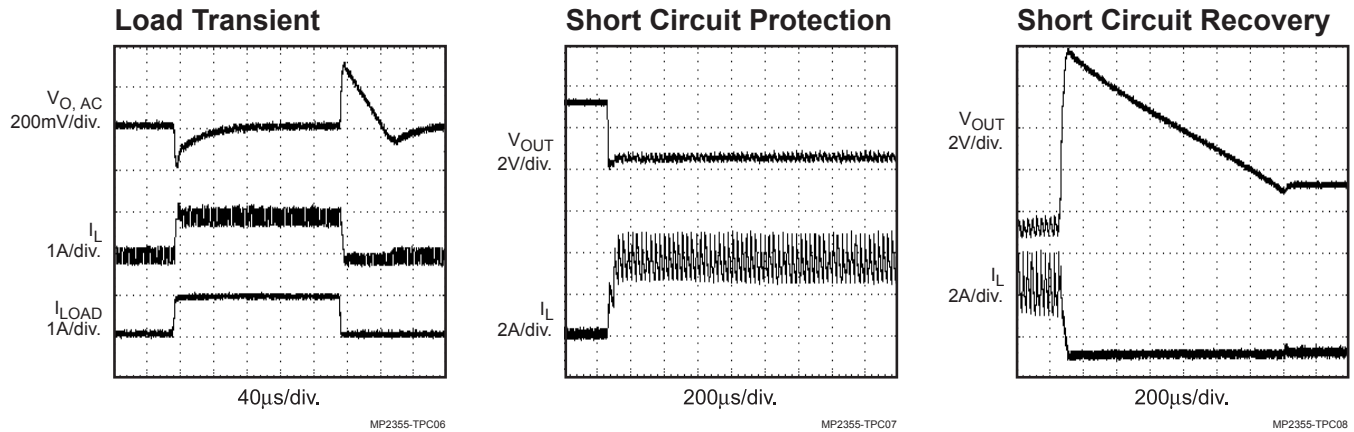
**PIN FUNCTIONS**

Pin #	Name	Description
1	SS	Soft-Start Control Input. SS controls the soft-start period. Connect a capacitor from SS to GND to set the soft-start period. A 0.1 $\mu F$ capacitor sets the soft-start period to 10ms. To disable the soft-start feature, leave SS unconnected.
2	BST	High-Side Gate Drive Boost Input. BST supplies the drive for the high-side N-Channel MOSFET switch. Connect a 10nF or greater capacitor from LX to BST to power the high side switch.
3	VIN	Power Input. VIN supplies the power to the IC, as well as the step-down converter switches. Drive VIN with a 4.75V to 23V power source. Bypass VIN to GND with a suitably large capacitor to eliminate noise on the input to the IC. See <i>Input Capacitor</i>
4	LX	Power Switching Output. LX is the switching node that supplies power to the output. Connect the output LC filter from LX to the output load. Note that a capacitor is required from LX to BST to power the high-side switch.
5	GND	Ground. (Note: Connect the exposed pad on backside to Pin 5.)
6	FB	Feedback Input. FB senses the output voltage to regulate that voltage. Drive FB with a resistive voltage divider from the output voltage. The feedback threshold is 1.222V. See <i>Setting the Output Voltage</i>
7	COMP	Compensation Node. COMP is used to compensate the regulation control loop. Connect a series RC network from COMP to GND to compensate the regulation control loop. In some cases, an additional capacitor from COMP to GND is required. See <i>Compensation</i>
8	RUN	Enable/UVLO. A voltage greater than 2.71V enables operation. For complete low current shutdown the EN pin voltage needs to be less than 900mV.

**OPERATION**

The MP2355 is a current-mode step-down regulator. It regulates input voltages from 4.75V to 23V down to an output voltage as low as 1.222V, and is able to supply up to 3A of load current.

The MP2355 uses current-mode control to regulate the output voltage. The output voltage is measured at FB through a resistive voltage divider and amplified through the internal error amplifier. The output current of the transconductance error amplifier is presented at COMP where a network compensates the regulation control system. The voltage at COMP

is compared to the switch current measured internally to control the output voltage.

The converter uses an internal N-Channel MOSFET switch to step-down the input voltage to the regulated output voltage. Since the MOSFET requires a gate voltage greater than the input voltage, a boost capacitor connected between LX and BST drives the gate. The capacitor is internally charged while LX is low.

An internal 10Ω switch from LX to GND is used to insure that LX is pulled to GND when LX is low to fully charge the BST capacitor.

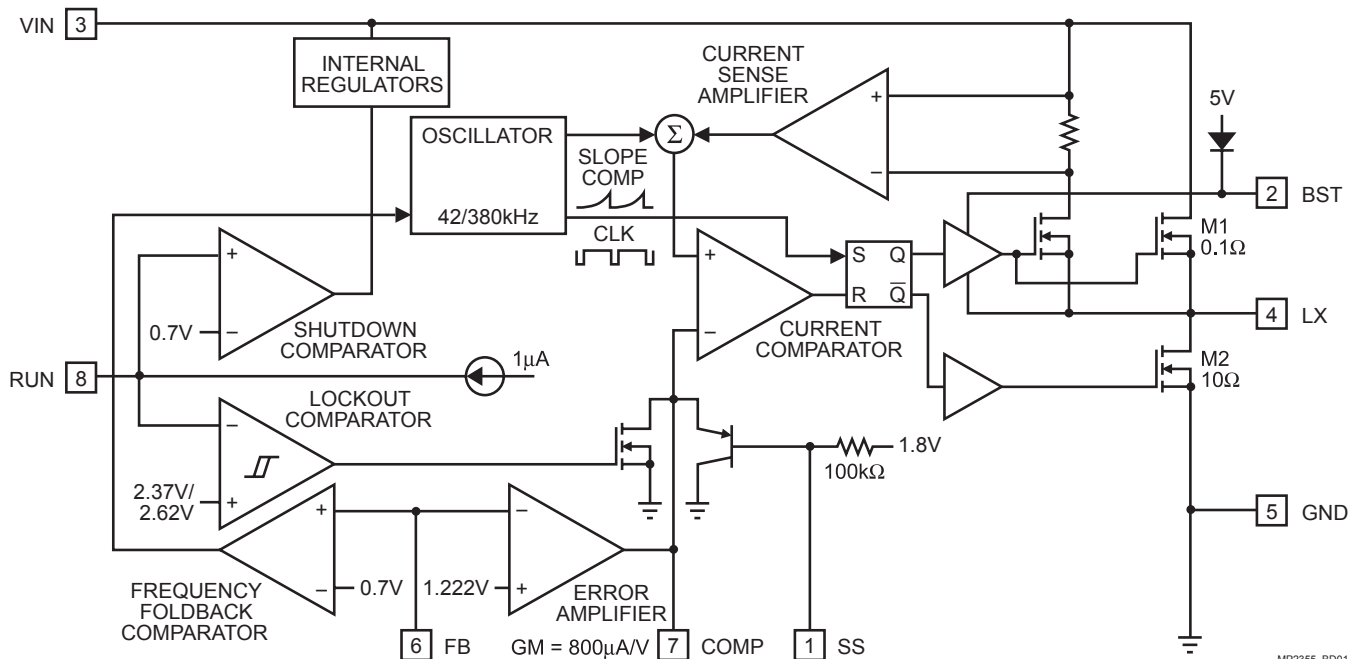

**Figure 1—Functional Block Diagram**

MP2355\_BD01

## APPLICATIONS INFORMATION

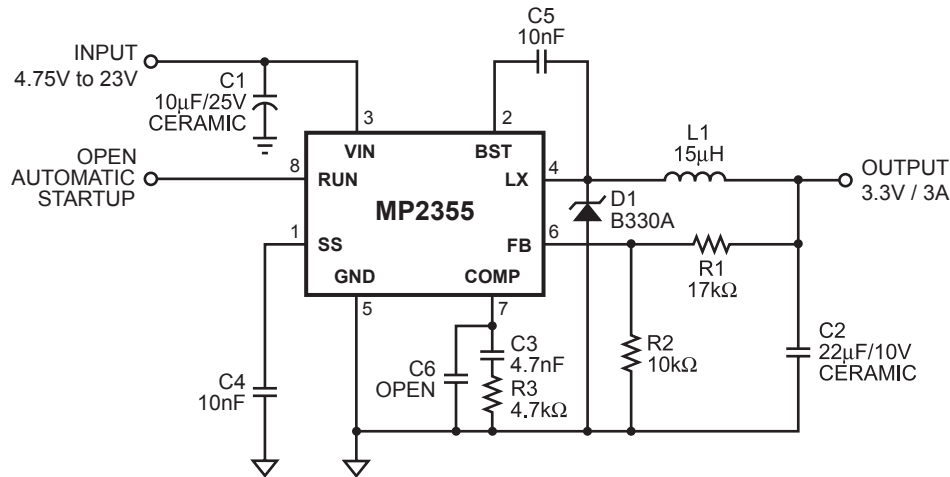

MP2355\_TAC\_F02

**Figure 2—MP2355 with Murata 22µF, 10V Ceramic Output Capacitor**

### COMPONENT SELECTION

#### Setting the Output Voltage

The output voltage is set using a resistive voltage divider from the output voltage to FB pin. The voltage divider divides the output voltage down to the feedback voltage by the ratio:

$$V_{FB} = V_{OUT} \frac{R2}{R1 + R2}$$

Thus the output voltage is:

$$V_{OUT} = 1.22 \times \frac{R1 + R2}{R2}$$

Where  $V_{FB}$  is the feedback voltage and  $V_{OUT}$  is the output voltage.

A typical value for R2 can be as high as 100kΩ, but a typical value is 10kΩ. Using that value, R1 is determined by:

$$R1 = 8.18 \times (V_{OUT} - 1.22)(k\Omega)$$

For example, for a 3.3V output voltage, R2 is 10kΩ, and R1 is 17kΩ.

#### Inductor

The inductor is required to supply constant current to the output load while being driven by the switched input voltage. A larger value inductor will result in less ripple current that will result in lower output ripple voltage. However, the larger value inductor will have a larger physical size, higher series resistance, and/or lower saturation current.

A good rule for determining the inductance to use is to allow the peak-to-peak ripple current in the inductor to be approximately 30% of the maximum switch current limit. Also, make sure that the peak inductor current is below the maximum switch current limit. The inductance value can be calculated by:

$$L = \frac{V_{OUT}}{f_s \times \Delta I_L} \times \left( 1 - \frac{V_{OUT}}{V_{IN}} \right)$$

Where  $V_{IN}$  is the input voltage,  $f_s$  is the 380KHz switching frequency, and  $\Delta I_L$  is the peak-to-peak inductor ripple current.

Choose an inductor that will not saturate under the maximum inductor peak current. The peak inductor current can be calculated by:

$$I_{LP} = I_{LOAD} + \frac{V_{OUT}}{2 \times f_s \times L} \times \left( 1 - \frac{V_{OUT}}{V_{IN}} \right)$$

Where  $I_{LOAD}$  is the load current.

Table 1 lists a number of suitable inductors from various manufacturers. The choice of which style inductor to use mainly depends on the price vs. size requirements and any EMI requirement.

**Table 1—Inductor Selection Guide**

Vendor/ Model	Core Type	Core Material	Package Dimensions (mm)		
			W	L	H
<b>Sumida</b>					
CR75	Open	Ferrite	7.0	7.8	5.5
CDH74	Open	Ferrite	7.3	8.0	5.2
CDRH5D28	Shielded	Ferrite	5.5	5.7	5.5
CDRH5D28	Shielded	Ferrite	5.5	5.7	5.5
<b>Sumida (continued)</b>					
CDRH6D28	Shielded	Ferrite	6.7	6.7	3.0
CDRH104R	Shielded	Ferrite	10.1	10.0	3.0
<b>Toko</b>					
D53LC Type A	Shielded	Ferrite	5.0	5.0	3.0
D75C	Shielded	Ferrite	7.6	7.6	5.1
D104C	Shielded	Ferrite	10.0	10.0	4.3
D10FL	Open	Ferrite	9.7	1.5	4.0
<b>Coilcraft</b>					
DO3308	Open	Ferrite	9.4	13.0	3.0
DO3316	Open	Ferrite	9.4	13.0	5.1

### Output Rectifier Diode

The output rectifier diode supplies the current to the inductor when the high-side switch is off. To reduce losses due to the diode forward voltage and recovery times, use a Schottky diode.

Choose a diode which has a maximum reverse voltage rating is greater than the maximum input voltage, and whose current rating is greater than the maximum load current. Table 2 lists example Schottky diodes and manufacturers.

**Table 2—Diode Selection Guide**

Diode	Voltage/Current Rating	Manufacture
SK33	30V, 3A	Diodes Inc.
SK34	40V, 3A	Diodes Inc.
B330	30V, 3A	Diodes Inc.
B340	40V, 3A	Diodes Inc.
MBRS330	30V, 3A	On Semiconductor
MBRS340	40V, 3A	On Semiconductor

### Input Capacitor

The input current to the step-down converter is discontinuous, therefore a capacitor is required to supply the AC current to the step-down converter while maintaining the DC input voltage. Use low ESR capacitors for the best performance. Ceramic capacitors are preferred, but tantalum or low-ESR electrolytic capacitors may also suffice.

Since the input capacitor (C1) absorbs the input switching current it requires an adequate ripple current rating. The RMS current in the input capacitor can be estimated by:

$$I_{C1} = I_{LOAD} \times \sqrt{\frac{V_{OUT}}{V_{IN}} \times \left(1 - \frac{V_{OUT}}{V_{IN}}\right)}$$

The worst-case condition occurs at  $V_{IN} = 2V_{OUT}$ , where:

$$I_{C1} = \frac{I_{LOAD}}{2}$$

For simplification, choose the input capacitor whose RMS current rating greater than half of the maximum load current.

The input capacitor can be electrolytic, tantalum or ceramic. When using electrolytic or tantalum capacitors, a small, high quality ceramic capacitor, i.e. 0.1μF, should be placed as close to the IC as possible. When using ceramic capacitors, make sure that they have enough capacitance to provide sufficient charge to prevent excessive voltage ripple at input. The input voltage ripple caused by capacitance can be estimated by:

$$\Delta V_{IN} = \frac{I_{LOAD}}{f_s \times C1} \times \frac{V_{OUT}}{V_{IN}} \times \left(1 - \frac{V_{OUT}}{V_{IN}}\right)$$



### Output Capacitor

The output capacitor is required to maintain the DC output voltage. Ceramic, tantalum, or low ESR electrolytic capacitors are recommended. Low ESR capacitors are preferred to keep the output voltage ripple low. The output voltage ripple can be estimated by:

$$\Delta V_{OUT} = \frac{V_{OUT}}{f_s \times L} \times \left(1 - \frac{V_{OUT}}{V_{IN}}\right) \times \left(R_{ESR} + \frac{1}{8 \times f_s \times C2}\right)$$

Where L is the inductor value, C2 is the output capacitance value, and  $R_{ESR}$  is the equivalent series resistance (ESR) value of the output capacitor.

In the case of ceramic capacitors, the impedance at the switching frequency is dominated by the capacitance. The output voltage ripple is mainly caused by the capacitance. For simplification, the output voltage ripple can be estimated by:

$$\Delta V_{OUT} = \frac{V_{OUT}}{8 \times f_s^2 \times L \times C2} \times \left(1 - \frac{V_{OUT}}{V_{IN}}\right)$$

In the case of tantalum or electrolytic capacitors, the ESR dominates the impedance at the switching frequency. For simplification, the output ripple can be approximated to:

$$\Delta V_{OUT} = \frac{V_{OUT}}{f_s \times L} \times \left(1 - \frac{V_{OUT}}{V_{IN}}\right) \times R_{ESR}$$

The characteristics of the output capacitor also affect the stability of the regulation system. The MP2355 can be optimized for a wide range of capacitance and ESR values.

### Compensation Components

MP2355 employs current mode control for easy compensation and fast transient response. The system stability and transient response are controlled through the COMP pin. COMP pin is the output of the internal transconductance error amplifier. A series capacitor-resistor combination sets a pole-zero combination to control the characteristics of the control system.

The DC gain of the voltage feedback loop is given by:

$$A_{VDC} = R_{LOAD} \times G_{CS} \times A_{VEA} \times \frac{V_{FB}}{V_{OUT}}$$

Where  $A_{VEA}$  is the error amplifier voltage gain, 400V/V;  $G_{CS}$  is the current sense transconductance, 3.8A/V;  $R_{LOAD}$  is the load resistor value.

The system has two poles of importance. One is due to the compensation capacitor (C3) and the output resistor of error amplifier, and the other is due to the output capacitor and the load resistor. These poles are located at:

$$f_{P1} = \frac{G_{EA}}{2\pi \times C3 \times A_{VEA}}$$

$$f_{P2} = \frac{1}{2\pi \times C2 \times R_{LOAD}}$$

Where  $G_{EA}$  is the error amplifier transconductance, 800 $\mu$ A/V.

The system has one zero of importance, due to the compensation capacitor (C3) and the compensation resistor (R3). This zero is located at:

$$f_{Z1} = \frac{1}{2\pi \times C3 \times R3}$$

The system may have another zero of importance, if the output capacitor has a large capacitance and/or a high ESR value. The zero, due to the ESR and capacitance of the output capacitor, is located at:

$$f_{ESR} = \frac{1}{2\pi \times C2 \times R_{ESR}}$$

In this case (as shown in Figure 2), a third pole set by the compensation capacitor (C6) and the compensation resistor (R3) is used to compensate the effect of the ESR zero on the loop gain. This pole is located at:

$$f_{P3} = \frac{1}{2\pi \times C6 \times R3}$$



The goal of compensation design is to shape the converter transfer function to get a desired loop gain. The system crossover frequency where the feedback loop has the unity gain is important.

Lower crossover frequencies result in slower line and load transient responses, while higher crossover frequencies could cause system unstable. A good rule of thumb is to set the crossover frequency to approximately one-tenth of the switching frequency. Switching frequency for the MP2355 is 380KHz, so the desired crossover frequency is around 38KHz.

Table 3 lists the typical values of compensation components for some standard output voltages with various output capacitors and inductors. The values of the compensation components have been optimized for fast transient responses and good stability at given conditions.

**Table 3—Compensation Values for Typical Output Voltage/Capacitor Combinations**

V <sub>OUT</sub>	L1	C2	R3	C3	C6
2.5V	10µH min.	22µF Ceramic	3.9kΩ	5.6nF	None
3.3V	15µH min.	22µF Ceramic	4.7kΩ	4.7nF	None
5V	15µH min.	22µF Ceramic	7.5kΩ	2.7nF	None
12V	22µH min.	22µF Ceramic	15kΩ	1.5nF	None
2.5V	10µH min.	560µF Al. 30mΩ ESR	100kΩ	1nF	150pF
3.3V	15µH min.	560µF Al. 30mΩ ESR	120kΩ	1nF	120pF
5V	15µH min.	470µF Al. 30mΩ ESR	150kΩ	1nF	82pF
12V	22µH min.	220µF Al. 30mΩ ESR	169kΩ	1nF	39pF

To optimize the compensation components for conditions not listed in Table 2, the following procedure can be used.

1) Choose the compensation resistor (R3) to set the desired crossover frequency. Determine the R3 value by the following equation:

$$R3 = \frac{2\pi \times C2 \times f_c}{G_{EA} \times G_{CS}} \times \frac{V_{OUT}}{V_{FB}}$$

2) Choose the compensation capacitor (C3) to achieve the desired phase margin. For applications with typical inductor values, setting the compensation zero,  $f_{z1}$ , to less than one fourth of the crossover frequency provides sufficient phase margin. Determine the C3 value by the following equation:

$$C3 > \frac{4}{2\pi \times R3 \times f_c}$$

Where R3 is the compensation resistor value and  $f_c$  is the desired crossover frequency, 38KHz.

3) Determine if the second compensation capacitor (C6) is required. It is required if the ESR zero of the output capacitor is located at less than half of the 380KHz switching frequency, or the following relationship is valid:

$$\frac{1}{2\pi \times C2 \times R_{ESR}} < \frac{f_s}{2}$$

If this is the case, then add the second compensation capacitor (C6) to set the pole  $f_{p3}$  at the location of the ESR zero. Determine the C6 value by the equation:

$$C6 = \frac{C2 \times R_{ESR}}{R3}$$

### External Bootstrap Diode

It is recommended that an external bootstrap diode be added when the system has a 5V fixed input or the power supply generates a 5V output. This helps improve the efficiency of the regulator. The bootstrap diode can be a low cost one such as IN4148 or BAT54.

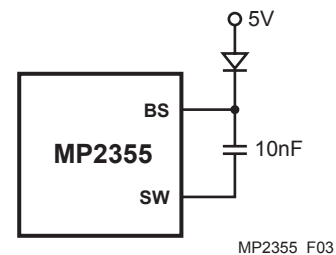

**Figure 3—External Bootstrap Diode**

This diode is also recommended for high duty cycle operation (when  $\frac{V_{OUT}}{V_{IN}} > 65\%$ ) and high output voltage ( $V_{OUT} > 12V$ ) applications.