

## DESCRIPTION

The MP24895 is step-down LED driver, which is designed in continuous current mode for driving the high-brightness LEDs from a wide input voltage of 6V to 36V.

The MP24895 employs a hysteretic control scheme to regulate LED current. Moreover, the control scheme provides optimal loop stabilization and a very quick response time. For a high accuracy, the MP24895 senses LED current by an external high-side resistor. Its low 100mV average feedback voltage reduces power loss and improves the efficiency.

The MP24895 implements PWM and analog dimming together on the EN/DIM pin.

The MP24895 includes under-voltage lockout, and thermal overload protection to prevent damage in the event of an output overload.

The MP24895 is available in TSOT23-5 and QFN-6 packages.

## FEATURES

- Internal 36V MOSFET
- Wide 6V-to-36V Input Range
- 1A Output Current
- High Efficiency
- Hysteretic Control
- PWM and Analog Dimming
- 1000:1 PWM Dimming Resolution
- UVLO, Thermal Shutdown
- Available in TSOT23-5 and QFN-6 Packages

## APPLICATIONS

- Low-Voltage Halogen Replacement
- Low-Voltage General Illumination
- Automotive/Decorative LED Lighting
- Signs/Emergency Lighting
- LED Backlighting

All MPS parts are lead-free and adhere to the RoHS directive. For MPS green status, please visit MPS website under Products, Quality Assurance page. "MPS" and "The Future of Analog IC Technology" are registered trademarks of Monolithic Power Systems, Inc.

## TYPICAL APPLICATION

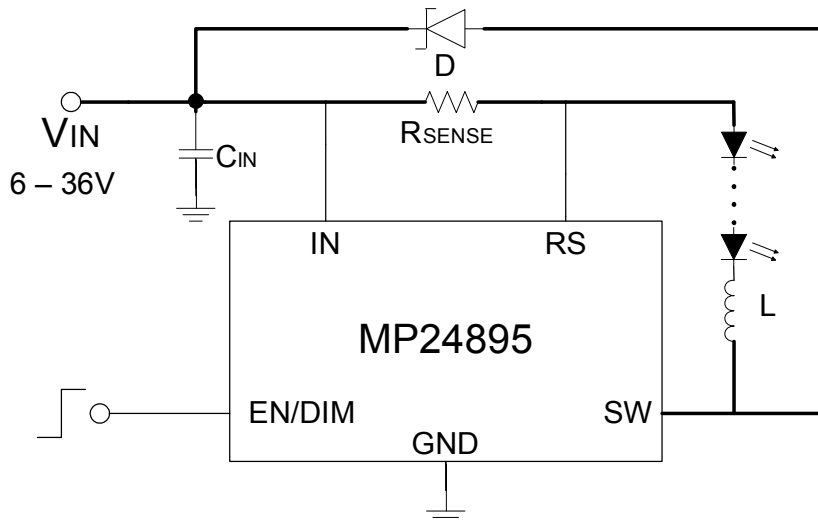

### ORDERING INFORMATION

Part Number*	Package	Top Marking
MP24895GJ*	TSOT23-5	AKD
MP24895GQ**	QFN-6 (3x3mm)	AKD

\* For Tape & Reel, add suffix -Z (e.g. MP24895GJ-Z);

\*\*For Tape & Reel, add suffix -Z (e.g. MP24895GQ-Z);

### PACKAGE REFERENCE

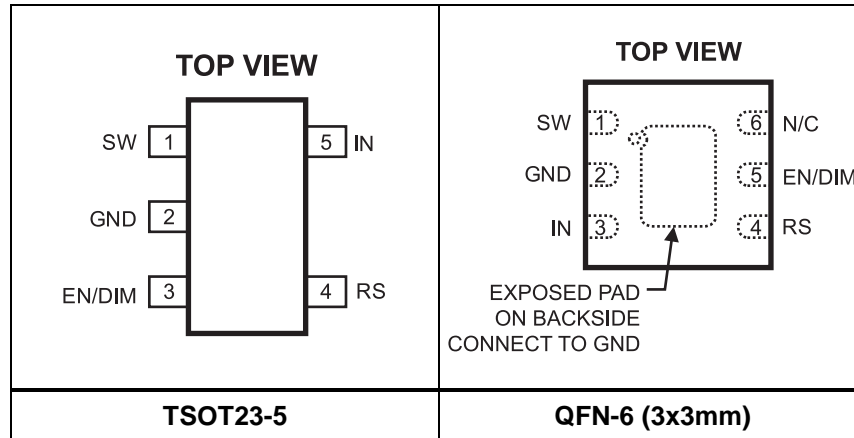

#### ABSOLUTE MAXIMUM RATINGS <sup>(1)</sup>

$V_{IN}, V_{SW}$ .....	-0.3V to +40V
$V_{RS}$ .....	$V_{IN}-5V$ to $V_{IN}$
All Other Pins.....	-0.3V to +6.3V
Continuous Power Dissipation ( $T_A = +25^\circ\text{C}$ ) <sup>(2)</sup>	
TSOT23-5.....	1.1W
QFN-6 (3x3mm).....	2.5W
Junction Temperature.....	150°C
Lead Temperature.....	260°C
Storage Temperature.....	-65°C to +150°C

#### Recommended Operating Conditions <sup>(3)</sup>

Supply Voltage $V_{IN}$ .....	6V to 36V
Operating Junction Temp. ( $T_J$ )....	-40°C to +125°C

#### Thermal Resistance <sup>(4)</sup>

	$\theta_{JA}$	$\theta_{JC}$
TSOT23-5 .....	110 .....	55 ... °C/W
QFN-6 (3x3mm) .....	50 .....	14 ... °C/W

#### Notes:

- Exceeding these ratings may damage the device.
- The maximum allowable power dissipation is a function of the maximum junction temperature  $T_J(\text{MAX})$ , the junction-to-ambient thermal resistance  $\theta_{JA}$ , and the ambient temperature  $T_A$ . The maximum allowable continuous power dissipation at any ambient temperature is calculated by  $P_D(\text{MAX}) = (T_J(\text{MAX}) - T_A) / \theta_{JA}$ . Exceeding the maximum allowable power dissipation will cause excessive die temperature, and the regulator will go into thermal shutdown. Internal thermal shutdown circuitry protects the device from permanent damage.
- The device is not guaranteed to function outside of its operation conditions.
- Measured on JESD51-7 4-layer board.

## ELECTRICAL CHARACTERISTICS

$V_{IN} = 24V$ ,  $T_J = -40^{\circ}C$  to  $125^{\circ}C$ <sup>(6)</sup>, unless otherwise noted.

Parameter	Symbol	Condition	Min	Typ	Max	Units
Input Voltage	$V_{IN}$		6		36	V
IN Under-Voltage Lockout	$V_{IN\_UVLO}$	$V_{IN}$ Rising	4.7	5.3	5.9	V
Under-Voltage Lockout Hysteresis				700		mV
Shutdown Supply Current	$I_{SD}$			170	250	$\mu A$
Quiescent Supply Current	$I_Q$	No Switching		0.7	1.1	mA
Feedback Reference Voltage (with respect to $V_{IN}$ )	$V_{IN-V_{RS}}$	For $T_J=25^{\circ}C$ , $V_{EN/DIM}=1.28V$	94	100	106	mV
		For $T_J=-40^{\circ}C$ to $125^{\circ}C$ $V_{EN/DIM}=1.28V$	92		108	mV
EN/DIM Enable High Voltage	$V_{EN\_HIGH}$	$V_{EN}$ Rising	0.19	0.25	0.31	V
EN/DIM Enable Hysteresis	$V_{EN\_HYS}$			50	90	mV
EN/DIM Pull-Up Resistor	$R_{EN}$	$V_{EN/DIM}=0.3V$		45		k $\Omega$
Internal Reference Voltage	$V_{REF}$		1.24	1.28	1.32	V
Switch On Resistance	$R_{DS\_ON}$			0.2	0.4	$\Omega$
Minimum On Time <sup>(5)</sup>	$t_{ON\_MIN}$			100		ns
Minimum Off Time <sup>(5)</sup>	$t_{OFF\_MIN}$			80		ns
Thermal Shutdown Temperature <sup>(5)</sup>	$T_{OTP}$			150		$^{\circ}C$
Thermal Shutdown Hysteresis <sup>(5)</sup>	$T_{OTP\_HYS}$			15		$^{\circ}C$

**Notes:**

5) Guaranteed by design

6) Not test in production, guaranteed by characterization. Typical value represent the most likely parametric norm at  $+25^{\circ}C$

## TYPICAL CHARACTERISTICS

$V_{IN} = 18V$ ,  $V_{OUT} = 10V$ ,  $L = 47\mu H$ ,  $T_A = 25^\circ C$ , unless otherwise noted.

**VIN UVLO**

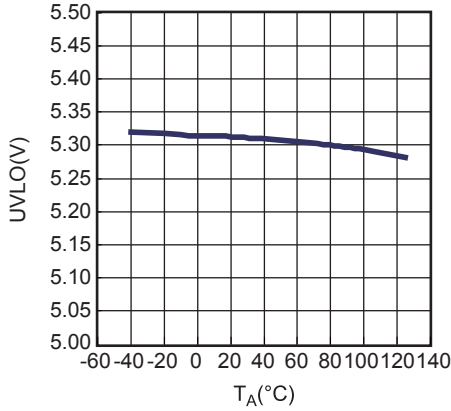

**EN UVLO**

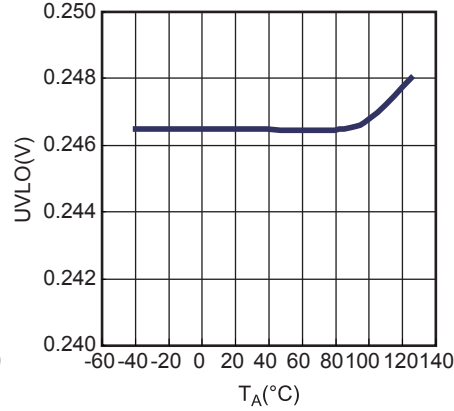

**VRS**

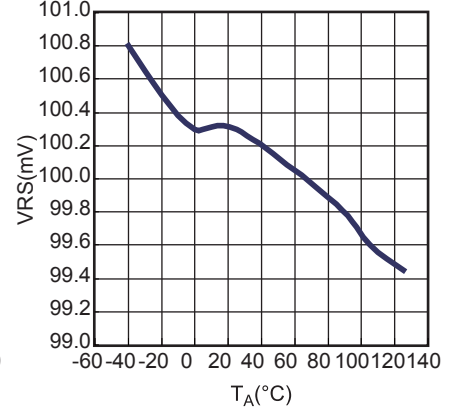

**RDSON**

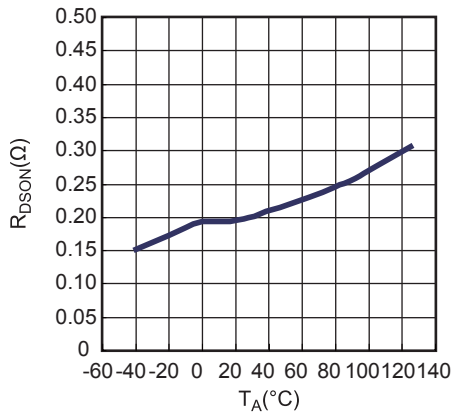

**Reference Voltage**

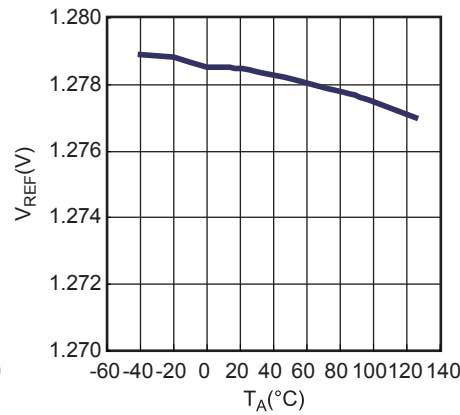

**TYPICAL PERFORMANCE CHARACTERISTICS (continued)**
 $V_{IN} = 18V$ ,  $V_{OUT} = 10V$ ,  $L = 47\mu H$ ,  $T_A = 25^\circ C$ , unless otherwise noted.

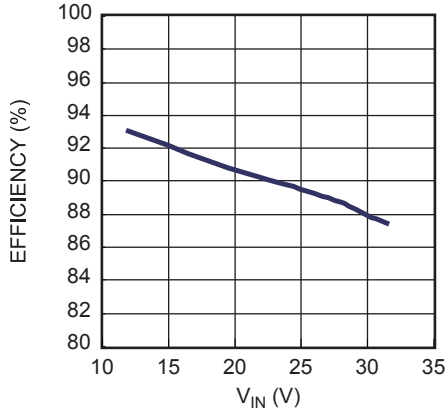
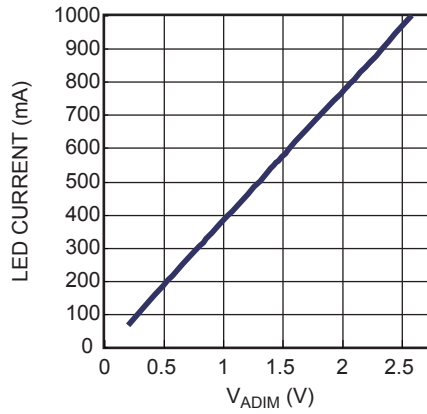
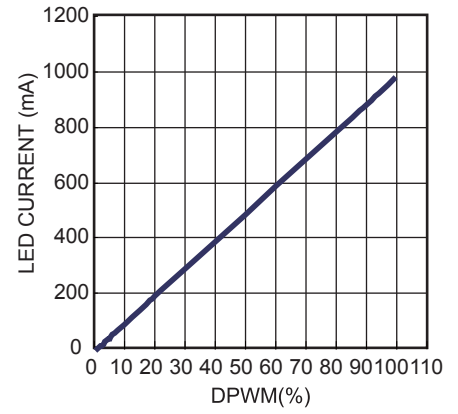
**Efficiency Test**

**Analog Dimming**

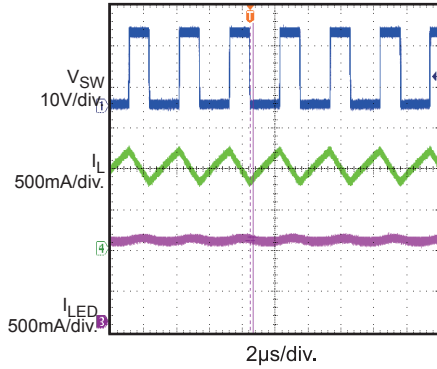
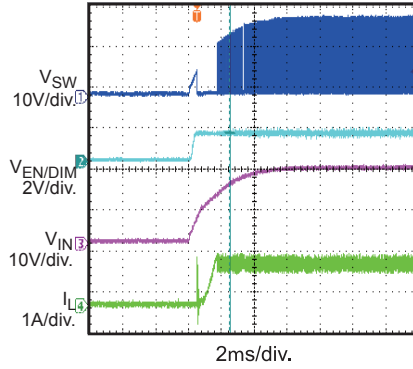
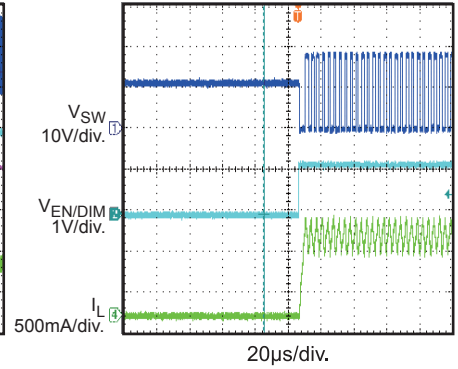
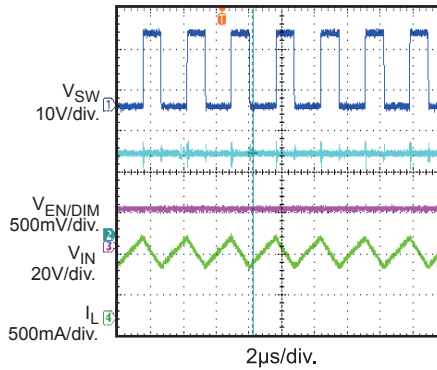
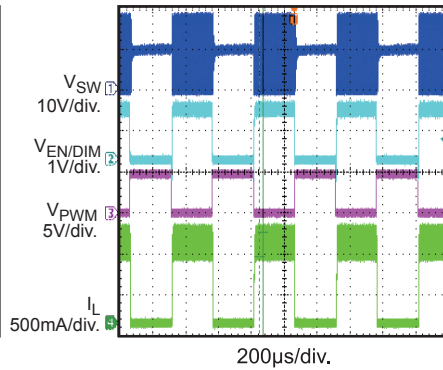
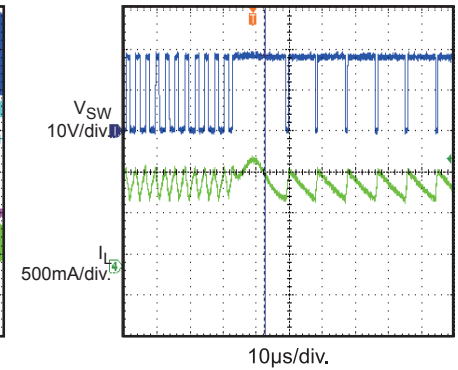
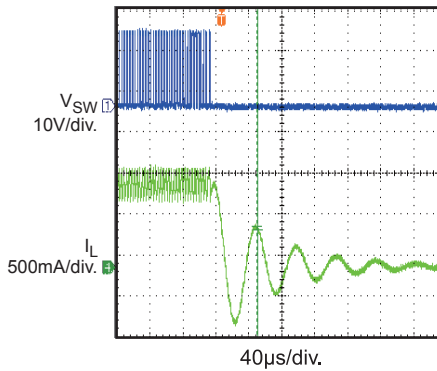
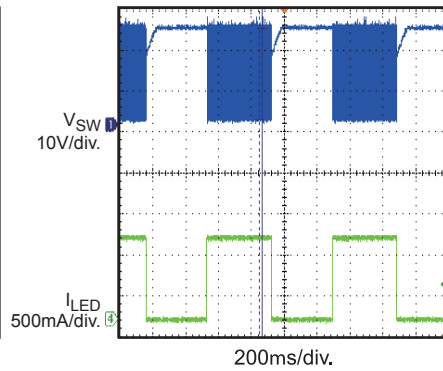
**PWM Dimming**

**TYPICAL PERFORMANCE CHARACTERISTICS (continued)**
 $V_{IN} = 18V$ ,  $V_{OUT} = 10V$ ,  $L = 47\mu H$ ,  $T_A = 25^\circ C$ , unless otherwise noted.

**Steady State**

**VIN Start-up**

**VEN Start-up**

**Analog Dimming**
 $V_{EN/DIM} = 0.9V$ 

**PWM Dimming**
 $f_{PWM} = 2kHz$ ,  $D_{PWM} = 50\%$ 

**Short Protection**

**Open Protection**

**Over-Temperature Protection**
 $T_A = 125^\circ C$ 

## PIN FUNCTIONS

TSOT23-5 Pin#	QFN-6 (3x3mm) Pin#	Name	Description
1	1	SW	Drain of Internal MOSFET. Connect the inductor common terminal and Schottky anode to this pin.
2	2	GND	Ground.
3	5	EN/DIM	Enable/Dimming Command Input. For PWM dimming, apply a square wave signal to this pin. For analog dimming, apply a 0.3V-to-2.5V DC voltage to linearly control the LED current range from 25% to 200%. Turn off the output current when pulling this pin below 0.2V. Leave it open for normal operation ( $V_{EN/DIM}=1.28V$ ).
4	4	RS	LED Current Sense Input. Connect a current-sense resistor to program the LED average current to IN pin.
5	3	IN	Input Supply Pin. Connect an appropriate decoupling capacitor from the IN pin to GND.
	6	N/C	Not Connected.

FUNCTION DIAGRAM

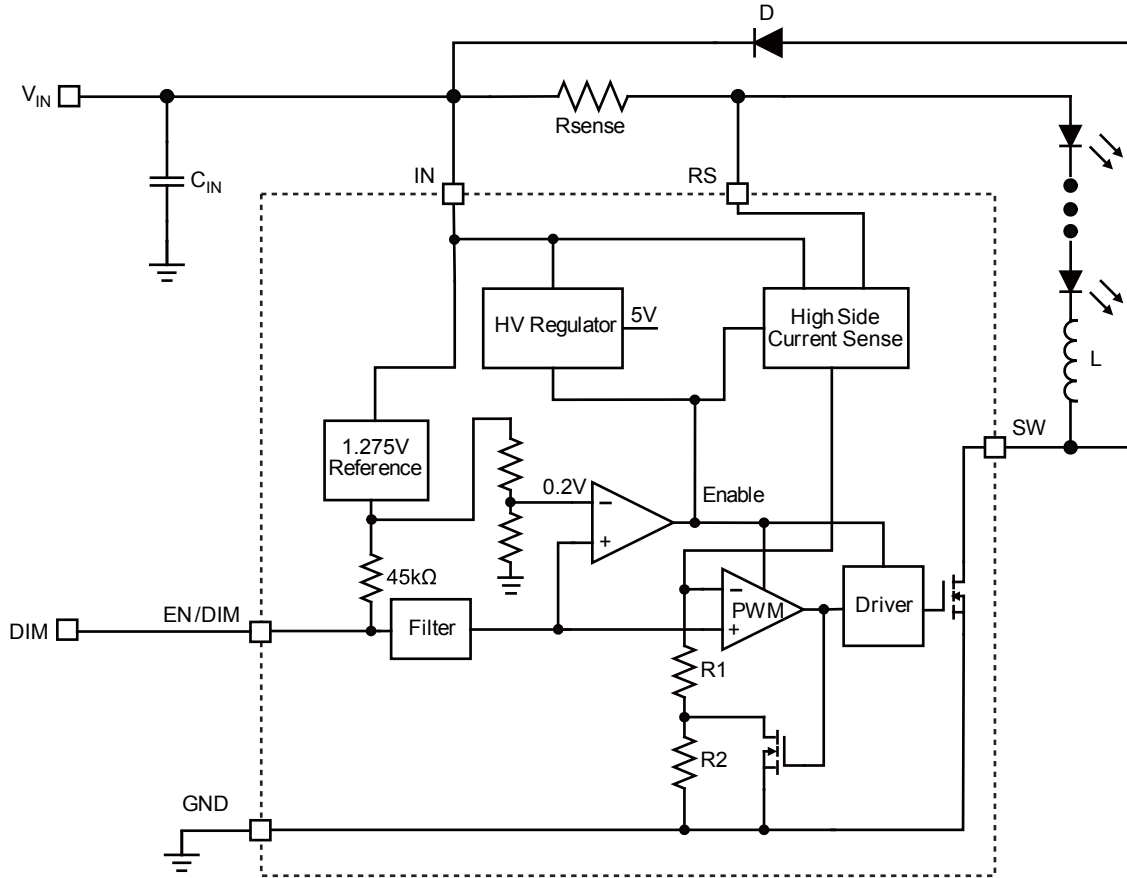

Figure 1: MP24895 Functional Block Diagram



## OPERATION

### Steady State

The MP24895 is a hysteretic-controlled, step-down LED driver that is easily configured for various applications with an input range from 6V to 36V. The converter employs a high-side current-sense resistor to detect and regulate the LED current. The voltage across the current-sense resistor is measured and regulated to within  $100\text{mV} \pm 20\text{mV}$ .

The internal 1.275V reference voltage provides a 0.2V reference to enable the part and a 1.275V pull-up voltage as current reference. When  $V_{\text{EN}} > 0.2\text{V}$ , the output of the comparator goes high and the other blocks are enabled.

A high-side resistor,  $R_{\text{SENSE}}$ , senses the output current. When the switch is on, R2 is shorted and R1 sets the output current upper-threshold. When the switch is off, R1 and R2 set the output current lower-threshold, and the ratio of R1 and R2 determines the current hysteresis.

### Enable Control

Once Input voltage is applied, the internal 1.275V reference is connected to EN/DIM pin through pull up resistor. If the EN/DIM pin is left open, the IC automatically starts up to the maximum brightness. Adding a capacitor to this pin can hereby program a soft-start time.

Applying an external voltage range from 0.2V to 1.25V to the EN/DIM pin linearly controls the current-sense voltage reference from 0mV to 100mV for analog dimming.

Applying an external PWM voltage with an amplitude of 1.25V to the EN/DIM pin achieves PWM dimming. For additional information on the flexible external PWM dimming method, please refer to the “Selecting Dimming Control Mode” section.

### System Soft Start

The voltage on the EN/DIM pin is the inductor current reference. An external capacitor from the EN/DIM pin to ground provides a soft-start delay. When  $V_{\text{IN}}$  starts, internal voltage source charges the capacitor from 0V to 1.25V for soft-start.

### Dimming Control

MP24895 provides two dimming methods: PWM dimming and DC analog dimming.

To use PWM dimming, apply a square wave to the EN/DIM pin. To use analog dimming, apply a 0.3V-to-2.5V DC voltage to this pin.

## APPLICATION INFORMATION

### Setting the LED Current

The LED current is set by the current-setting resistor between the IN and RS pins, where:

$$R_{SET} = 100\text{mV}/I_{LED}$$

For  $R_{SET} = 0.2\Omega$ , the LED current is set to 500mA

### Selecting the Inductor

Lower value of the inductor results in higher switching frequencies, leading to larger switch loss. For most applications, select a switching frequency between 200kHz and 600kHz. Estimate the inductor value based on the desired switching frequency, where:

$$L = \frac{\left(1 - \frac{V_{OUT}}{V_{IN}}\right) \times V_{OUT}}{0.4 \times I_{LED} \times f_{SW}}$$

For higher efficiency, use inductors with low DC resistance.

### Selecting the Diode

The output diode supplies current flowing path to the inductor when the internal MOSFET is off. To reduce losses due to the diode forward voltage and recovery time, use a Schottky diode. Select a diode rated with a reverse voltage greater than the input voltage. The average current rating must exceed the maximum expected load current, and the peak current rating must exceed the peak inductor current.

### Selecting the Input Capacitor

The input capacitor reduces the surge current drawn from the input supply and the switching noise from the device. Select capacitor value between 10 $\mu$ F and 22 $\mu$ F for most applications. The voltage rating should exceed the input voltage. Use a low-ESR capacitor input decoupling.

### Selecting the Output Capacitor

For most applications, an output capacitor is not necessary. But if the peak-to-peak ripple LED current must be less than 40% of the average current, add a capacitor across the LEDs, where a higher capacitor value leads to a proportionally lower ripple. A 2.2 $\mu$ F capacitor will meet most requirements.

### Selecting Soft-Start Capacitor

The delay time with the soft-start capacitor can be estimated by 0.2ms/nF. In PWM dimming, select a  $C < 2.2\text{nF}$  to eliminate its effect on the average LED current.

### Selecting Dimming Control Mode

MP24895 provides two dimming methods: DC analog dimming and PWM dimming.

#### 1. DC analog dimming mode

Apply a 0.3V-to-2.5V DC voltage to the EN/DIM pin. The voltage from 0.3V to 2.5V changes the inductor current reference directly and linearly controls the inductor current range from 25% to 200% (see Figure 2).

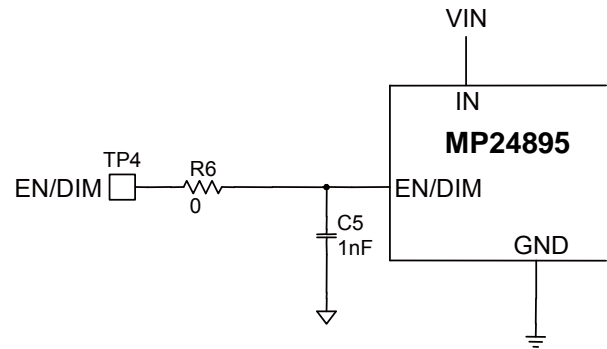

**Figure 2: Analog Dimming External Circuit**

#### 2. PWM dimming mode

Apply a 100Hz-to-2kHz square waveform to the EN/DIM pin. The average LED current is proportional to the PWM duty cycle. Add an NPN-transistor on/off circuit to separate the PWM signal from the current reference (see Figure 3) because this pin is pulled up by the 1.25V internal source as the inductor current reference. The minimum PWM amplitude is 1.5V.

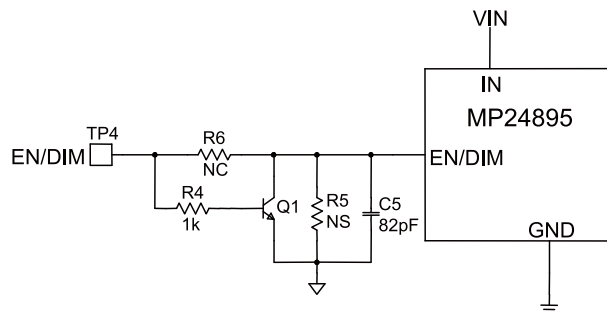

**Figure 3: PWM Dimming External Circuit**

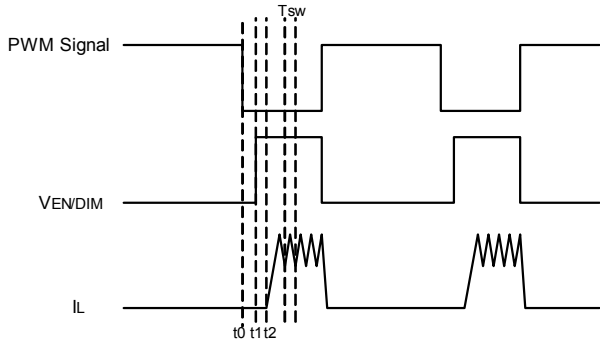

t0-t1: Delay time caused by transistor turning-off. For MMBT3904, t1 is about 1us-2us

t1-t2: Delay time caused by signal transmission (less than 1us).

Tsw: one switching period

The average LED current is proportional to duty cycle of PWM signal. For good PWM dimming linearity, inductor current has to achieve the peak threshold during PWM on time. The minimum PWM duty cycle can be estimated as below:

$$D_{min}/f_{pwm} = t_1 + t_2 + 4 \cdot D \cdot T_{sw}$$

### Circuit Layout Consideration

Pay careful attention to the PCB board layout and components placement. R<sub>SENSE</sub> should be placed close to the IN pin and RS pin to minimize set current error. The input loop—including the input capacitor, Schottky diode, and internal MOSFET—should be as short as possible.

## TYPICAL APPLICATION CIRCUITS

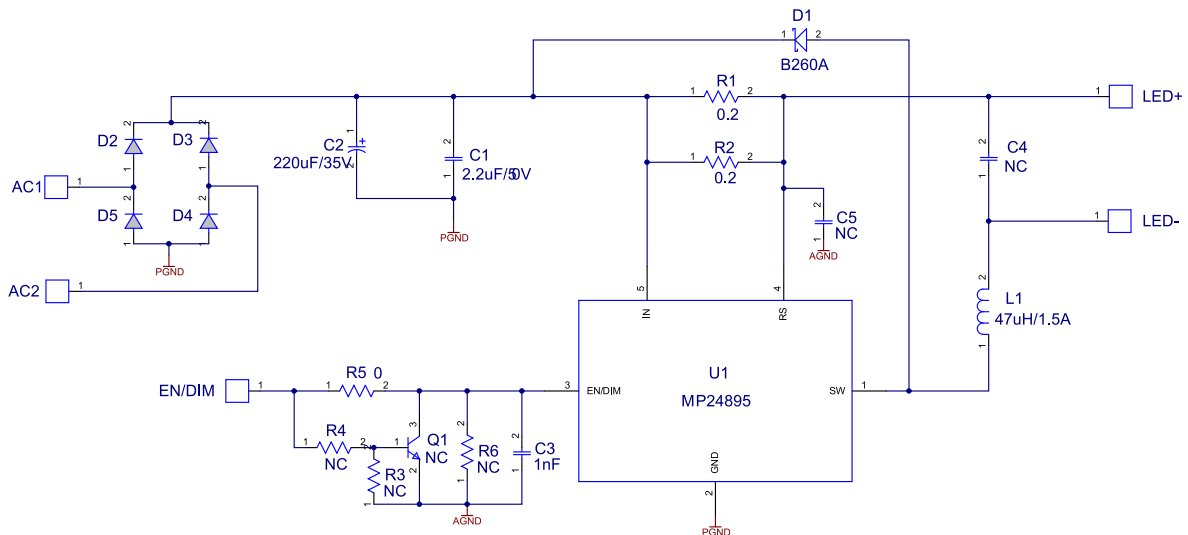

**Figure 4: Drive 3 LEDs in Series, 1A Current Output**

# PACKAGE INFORMATION

## TSOT23-5

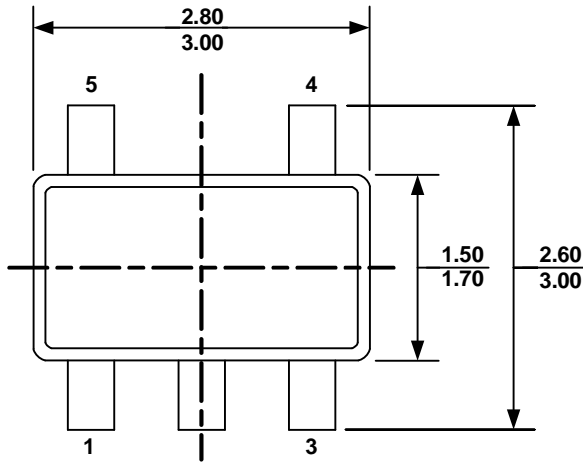

**TOP VIEW**

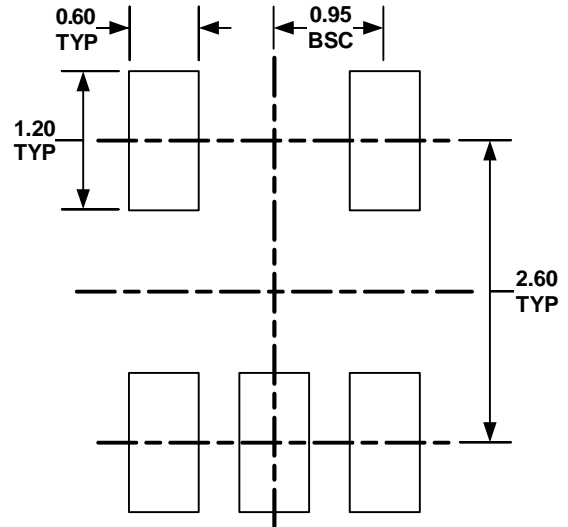

**RECOMMENDED LAND PATTERN**

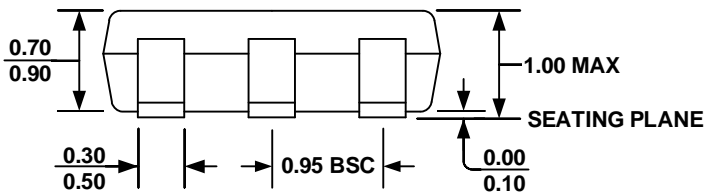

**FRONT VIEW**

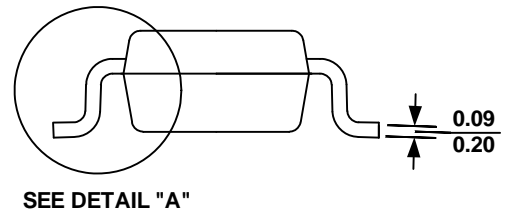

**SIDE VIEW**

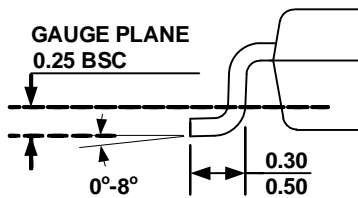

**DETAIL "A"**

**NOTE:**

- 1) ALL DIMENSIONS ARE IN MILLIMETERS
- 2) PACKAGE LENGTH DOES NOT INCLUDE MOLD FLASH, PROTRUSION OR GATE BURR.
- 3) PACKAGE WIDTH DOES NOT INCLUDE INTERLEAD FLASH OR PROTRUSION.
- 4) LEAD COPLANARITY (BOTTOM OF LEADS AFTER FORMING) SHALL BE 0.10 MILLIMETERS MAX
- 5) DRAWING CONFORMS TO JEDEC MO-193, VARIATION AA
- 6) DRAWING IS NOT TO SCALE