



The Future of Analog IC Technology®

# MP3356

## High Voltage Photo Flash Charger and IGBT Driver for DSC

### DESCRIPTION

The MP3356 is a fast, highly efficient and precision high voltage photo-flash charger for DSC xenon flash.

The MP3356 has a peak current of 1.5A. A 50V, 0.5Ω internal power switch lowers transformer turns ratio and switching losses associated with the primary leakage inductance and winding capacitance. Integrated secondary feedback resistors provide +/-2.5% output voltage charge accuracy. MP3356 also has an integrated IGBT driver.

MP3356 is available in the 10-pin, 2X2 flip chip package.

### FEATURES

- Integrated 50V, 0.5Ω Power Switch
- 1.5A peak current limit
- 2.5% Charge Accuracy
- <1uA Shutdown Current
- Integrated IGBT Driver

### APPLICATIONS

- Digital Still Cameras
- Optical Film Cameras

"MPS" and "The Future of Analog IC Technology" are Registered Trademarks of Monolithic Power Systems, Inc.

### TYPICAL APPLICATION

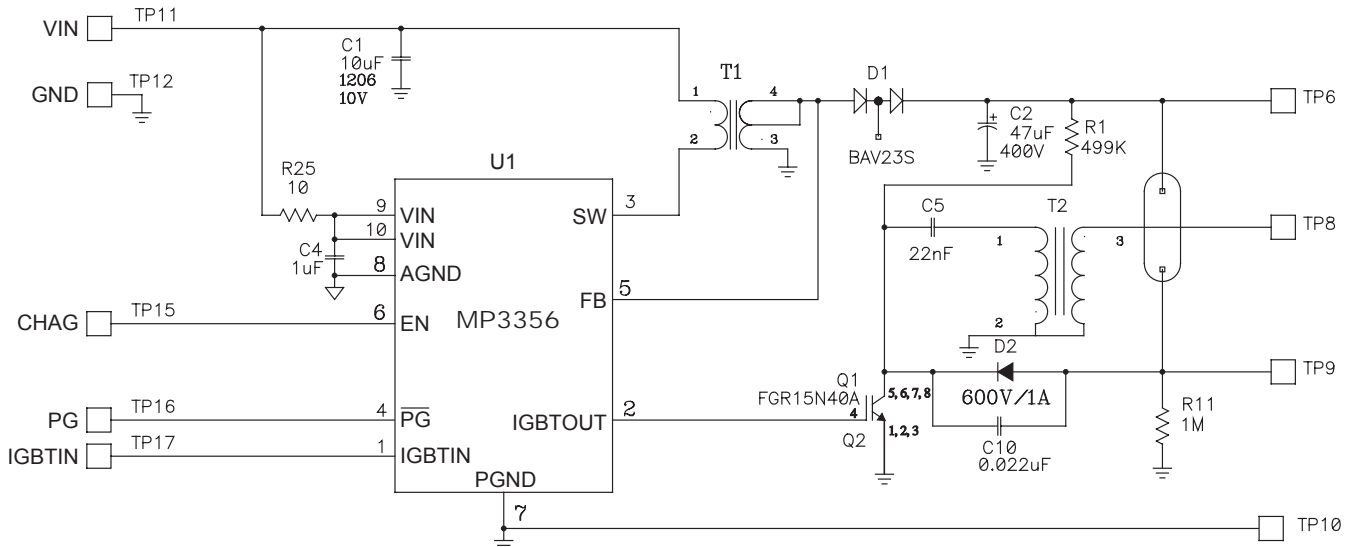

**ORDERING INFORMATION**

Part Number*	Package	Top Marking	Free Air Temperature (T <sub>A</sub> )
MP3356DG	10-pin, 2x2 Flip QFN	4PY	-40°C to +85°C

\* For Tape & Reel, add suffix -Z (e.g. MP3356DG-Z).  
 For RoHS Compliant Packaging, add suffix -LF (e.g. MP3356DG-LF-Z)

**PACKAGE REFERENCE**

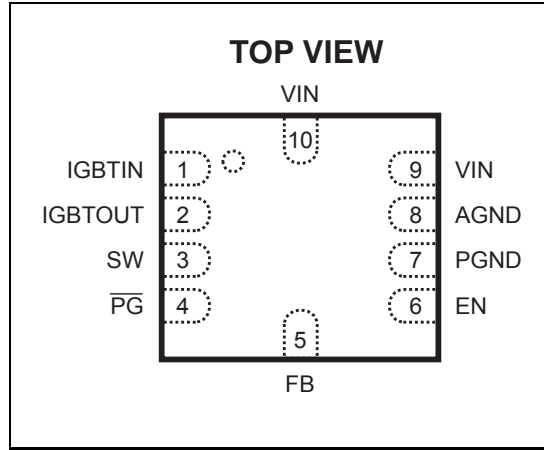

**ABSOLUTE MAXIMUM RATINGS** <sup>(1)</sup>

V <sub>IN</sub> to AGND	-0.3V to 6V
EN, IGBTIN, IGBTOUT, PG to AGND	-0.3V to 6V
FB to AGND	-60V to 350V
SW to AGND	-0.3V to 50V
PGND to AGND	-0.3V to 0.3V
Storage Temperature	-55°C to +150°C
Continuous Power Dissipation (T <sub>A</sub> = +25°C) <sup>(2)</sup>	1.6W
Junction Temperature	+150°C
Lead Temperature (Solder)	+260°C

**Recommended Operating Conditions** <sup>(3)</sup>

Supply Voltage V <sub>IN</sub>	2.8V to 6V
Operating Junct. Temp (T <sub>J</sub> )	-40°C to +125°C

<b>Thermal Resistance</b> <sup>(4)</sup>	<b>θ<sub>JA</sub></b>	<b>θ<sub>JC</sub></b>
2x2 Flip Chip	80	16 ... °C/W

**Notes:**

- Exceeding these ratings may damage the device.
- The maximum allowable power dissipation is a function of the maximum junction temperature T<sub>J</sub> (MAX), the junction-to-ambient thermal resistance θ<sub>JA</sub>, and the ambient temperature T<sub>A</sub>. The maximum allowable continuous power dissipation at any ambient temperature is calculated by P<sub>D</sub> (MAX) = (T<sub>J</sub> (MAX) - T<sub>A</sub>) / θ<sub>JA</sub>. Exceeding the maximum allowable power dissipation will cause excessive die temperature, and the regulator will go into thermal shutdown. Internal thermal shutdown circuitry protects the device from permanent damage.
- The device is not guaranteed to function outside of its operating conditions.
- Measured on JESD51-7, 4-layer PCB.

## ELECTRICAL CHARACTERISTICS

$V_{IN} = V_{EN} = 3.6V$ ,  $T_A = +25^{\circ}C$ , unless otherwise noted.

Parameter	Conditions	Min	Typ	Max	Unit
<b>Photoflash Capacitor Charger</b>					
$V_{IN}$ Voltage Range		2.8		6	V
$V_{IN}$ UVLO	Rising edge, hysteresis = 200mV typical			2.5	V
$V_{IN}$ Quiescent Current	V(EN)=High, V(FB) = 0		1	2	mA
$V_{IN}$ Quiescent Current	V(EN)=High, V(FB) = 336V			100	$\mu A$
Shutdown Current from $V_{IN}$	V(EN)=Low, $V_{IN}=3.6V$			1	$\mu A$
$V_{SW}$ Leakage Current	$V_{IN}=3.6V$ , $V_{SW}=50V$ , in Shutdown			1	$\mu A$
SW ON Resistance between SW and PGND	Switch turn-on, $I_{SW}=100mA$ , $V_{IN}=3.6V$		0.5		$\Omega$
EN Input High Voltage		2.4			V
EN Input Low Voltage				0.6	V
Pull-down Resistance of EN pin	V(EN)=3.6V		100		k $\Omega$
$I_{PEAK}$	Peak Current Limit	1.2	1.5	1.7	A
Charge completion detect voltage at FB		294	302	310	V
FB Resistance	V(FB)=30V		315		k $\Omega$
DCM Comparator threshold			5		V
$\overline{PG}$ Leakage Current	V(PG)=3.6V			1	$\mu A$
$\overline{PG}$ Output Low Voltage	$I_{SINK}= 2mA$			0.1	V
MAX $T_{ON}$	Maximum $T_{ON}$ time		70		$\mu S$
Thermal Shutdown	Rising edge, hysteresis = 15 $^{\circ}C$		150		$^{\circ}C$
<b>IGBT Driver</b>					
IGBTOUT pull-up ON resistance			6		$\Omega$
IGBTOUT pull-down ON resistance			6		$\Omega$
IGBTIN Input High Voltage		2.4			V
IGBTIN Input Low Voltage				0.6	V
Propagation delay	IGBTIN rising/falling edge to IGBTOUT rising/falling edge, $C_{gate}=6800pF$			40	nS
IGBTOUT rise time	$C_{gate}=6800pF$		130		nS
IGBTOUT fall time	$C_{gate}=6800pF$		180		nS
Pull down resistance of IGBTIN			90		k $\Omega$

## PIN FUNCTIONS

Pin #	Name	Description
1	IGBTIN	Logic Input Pin for IGBT Drive.
2	IGBTOUT	Output Drive for IGBT Gate. Connect this pin to the gate of the IGBT.
3	SW	Switch Pin. This is the drain of the internal power switch.
4	$\overline{\text{PG}}$	Open-Drain Power-Ready Output. PG becomes low when the output voltage is reached.
5	FB	Feedback Pin. Its trip voltage is 300V
6	EN	Charge Enable Pin. A low to high transition on this pin puts the part into power delivery mode. Once the target voltage is reached, the part will stop charging the output. Toggle this pin will start charging again. Bring this pin low will terminate the power delivery and put the part in shutdown.
7	PGND	Power Ground
8	AGND	Analog ground. Tie it directly to local ground plane.
9,10	VIN	Input Supply Pin. Connect it to system supply voltage. Bypass VIN to AGND with a 0.1uF or greater ceramic capacitor.

## TYPICAL PERFORMANCE CHARACTERISTICS

T<sub>A</sub> = +25°C, unless otherwise noted.

**Charge Time vs. Input Voltage**

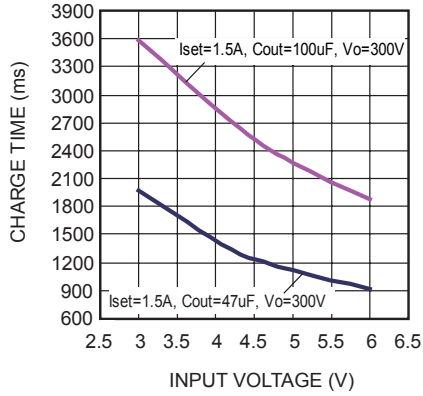

**Efficiency**

V<sub>in</sub>=3V, I<sub>set</sub>=1.5A  
with 1:8 transformer

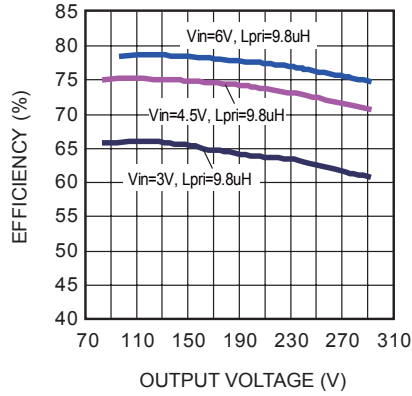

**Line Regulation**

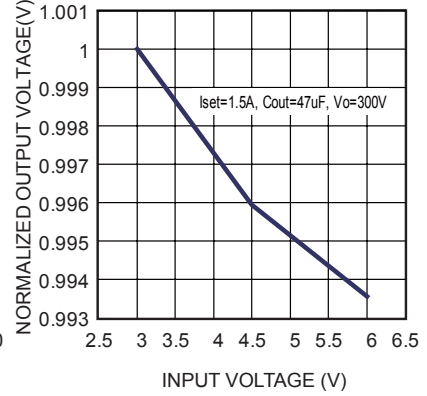

**Output Voltage vs. Input Voltage**

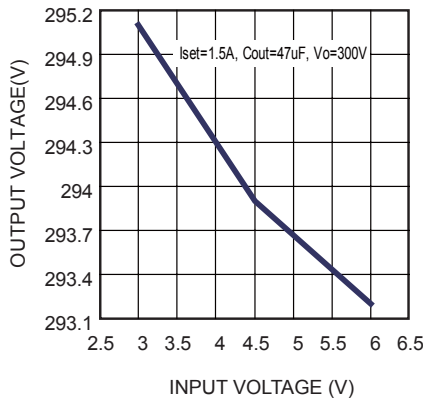

**TYPICAL PERFORMANCE CHARACTERISTICS** (continued)

T<sub>A</sub> = +25°C, unless otherwise noted.

**Switching Waveform**

V<sub>in</sub>=3.3V, V<sub>o</sub>=300V, I<sub>set</sub>=1.5A

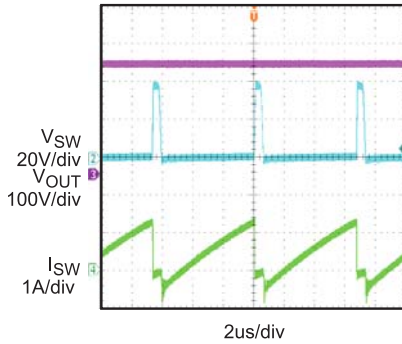

**Switching Waveform**

V<sub>in</sub>=5.0V, V<sub>o</sub>=300V, I<sub>set</sub>=1.5A

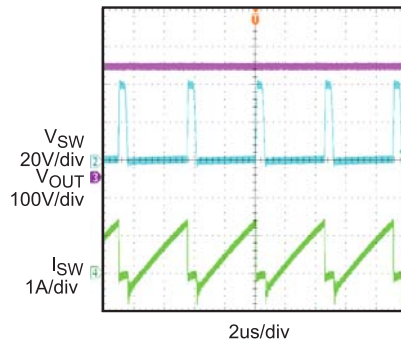

**Charging Waveform**

V<sub>in</sub>=3.3V, V<sub>o</sub>=300V, I<sub>set</sub>=1.5A, C<sub>out</sub>=47μF

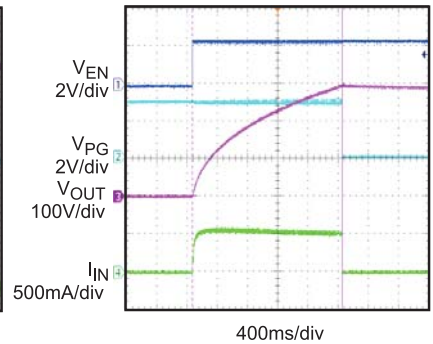

**Charging Waveform**

V<sub>in</sub>=5.0V, V<sub>o</sub>=300V, I<sub>set</sub>=1.5A, C<sub>out</sub>=47μF

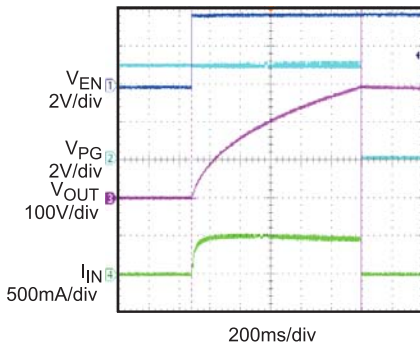

**Charging Waveform**

V<sub>in</sub>=3.3V, V<sub>o</sub>=300V, I<sub>set</sub>=1.5A, C<sub>out</sub>=100μF

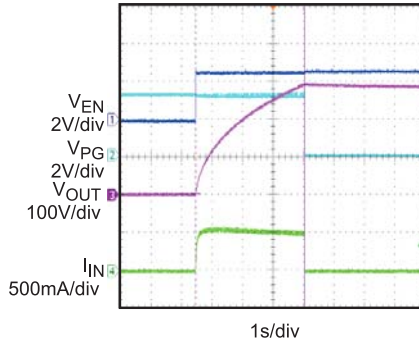

**Charging Waveform**

V<sub>in</sub>=5V, V<sub>o</sub>=300V, I<sub>set</sub>=1.5A, C<sub>out</sub>=100μF

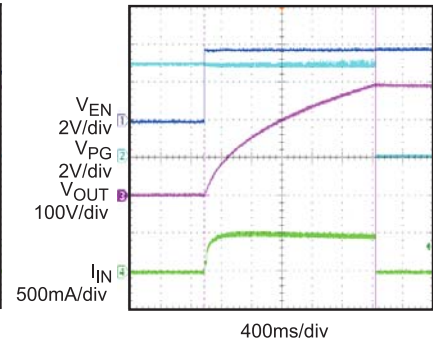

**Flash**

V<sub>out</sub> = 300V, C<sub>o</sub> = 47μF

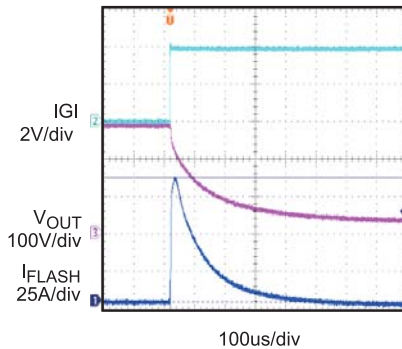

**BLOCK DIAGRAM**

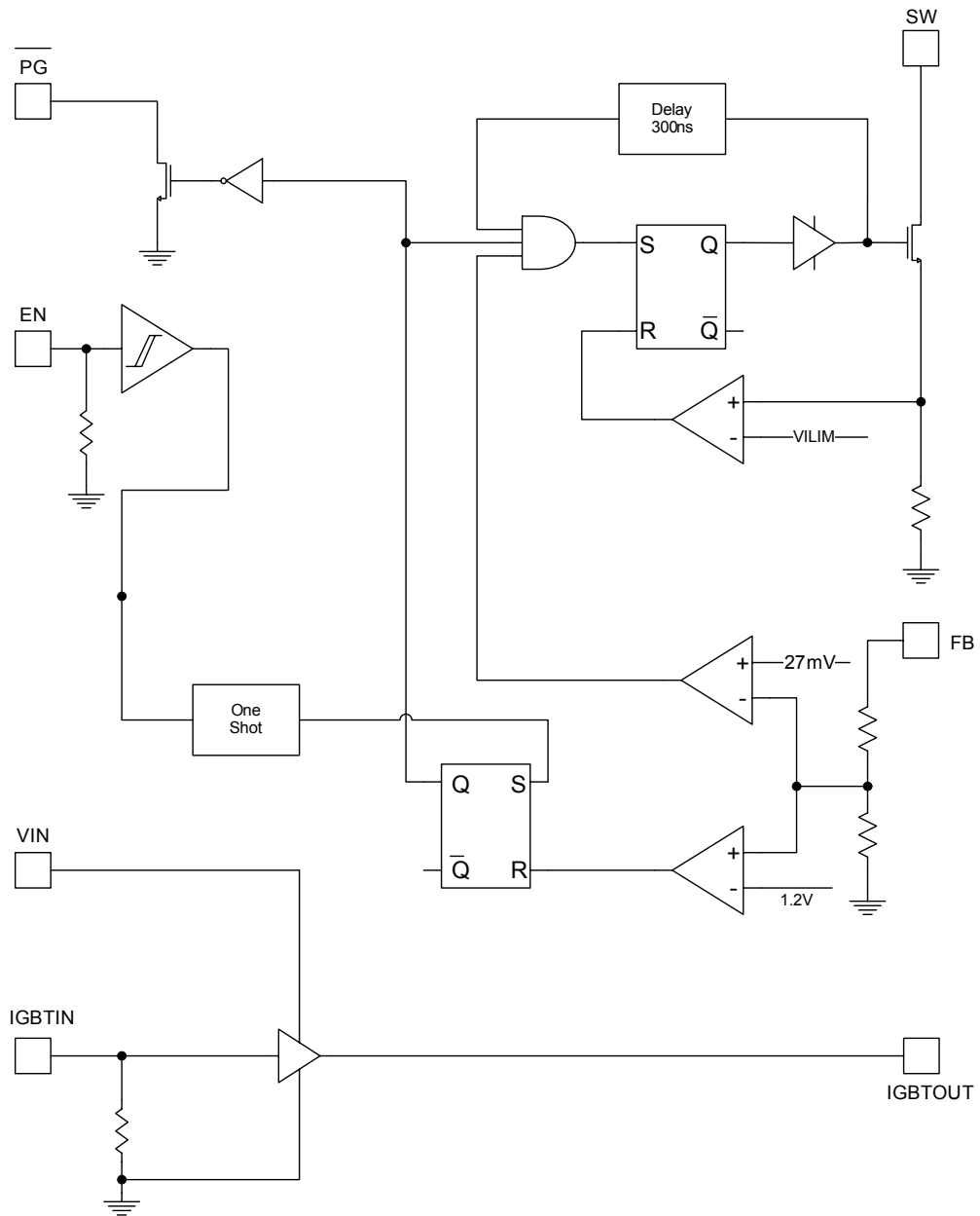

**Figure 1—Functional Block Diagram**

## OPERATION

The MP3356 controlled flyback charger operates in critical conduction mode with 1.5A peak current. The output voltage is divided down through an internal 300: 1 resistive divider from the positive terminal of the transformer secondary (FB pin) and compares it with an internal 1.2V reference. The low to high transition of the EN pin will enable the flyback converter to switch.

A constant  $T_{OFF}$  of 20 $\mu$ s is used when the output voltage is below 20V to avoid inrush current. The boundary mode operation will follow to minimize charge time when the output voltage is above 20V. A minimum  $T_{OFF}$  of 200ns serves as

blanking for turn off transition. The circuit will stop switching and  $\overline{PG}$  will be pulled low once the flash capacitor is charged to 300V. This value is set by the internal 300:1 R divider and the 1.2V reference. When charge is complete, the part will shut down its internal circuitry and draw less than 100uA drawn from  $V_{in}$ . The EN pin will restart the charge. Bringing the EN pin low terminates the power delivery and puts the part in shutdown. A maximum  $T_{ON}$  timer prevents pulling current from a depleted battery. If the ON time exceeds the maximum  $T_{ON}$ , the switch is forced OFF regardless of  $I_{PEAK}$  detection.



## APPLICATION INFORMATION

### Charge Speed

The output capacitor charging speed is determined by:

$$T_{\text{charge}} \propto \frac{I_{\text{LIM}}}{V_{\text{IN}} + \frac{N}{V_{\text{OUT}}}}$$

### Primary Inductance

The primary inductance is calculated based on the minimum off time period:

$$I_{\text{primary}} \geq \frac{V_{\text{OUT}} T_{\text{min,off}}}{N I_{\text{PEAK}}}$$

$V_{\text{OUT}}$ : output voltage about 300V

$T_{\text{MIN-OFF}}$  Minimum off time 200ns.

$I_{\text{PEAK}}$ : primary peak current

### Turns Ratio

The minimum turns ratio of the flyback transformer is obtained as:

$$N \geq \frac{V_{\text{OUT}}}{V_{\text{ds}} - V_{\text{IN}}}$$

$V_{\text{DS}}$ : FET drain-source voltage

$V_{\text{IN}}$ : Input voltage 3~5V

### Output Diode Selection

The reverse voltage of the output diode is determined by:

$$V_{\text{D}} = V_{\text{OUT}} + N V_{\text{IN}}$$