

### DESCRIPTION

The MP6922 is a dual fast turn-off intelligent controller to drive two N-CH power MOSFETs in LLC resonant converters for synchronous rectification.

The IC regulates the forward voltage drop of the power switch to about 70mV and turns it off before the voltage goes negative.

MP6922 has a light-load function to latch-off the gate driver at light load condition, during which only about 600 $\mu$ A quiescent current is consumed.

The fast turn-off speed of MP6922 makes both CCM and DCM driving available. An internal Reverse Current Protection (RCP) function ensures safe operation of the MOSFETs in high frequency CCM condition.

MP6922 requires a minimum number of readily available standard external components and is available in SOIC8E, SOIC8 or SOIC14 package.

### FEATURES

- Works with both Standard and Logic Level FETs
- Compatible with Energy Star, 0.5W Standby Requirements
- $V_{DD}$  Range From 8V to 24V
- 70m VDS Regulation Function <sup>(1)</sup>
- Fast Turn-off Total Delay of 20ns
- Reverse Current Protection Function
- Max 300kHz Switching Frequency
- Light Load Mode Function <sup>(1)</sup> with <600 $\mu$ A Quiescent Current
- Supports CCM, CrCM and DCM Operation Mode
- Available in SOIC8E, SOIC8 or SOIC14 package

### APPLICATIONS

- AC-DC Adapter
- LCD & PDP TV
- Telecom SMPS

All MPS parts are lead-free and adhere to the RoHS directive. For MPS green status, please visit MPS website under Quality Assurance.

"MPS" and "The Future of Analog IC Technology" are Registered Trademarks of Monolithic Power Systems, Inc.

#### Notes:

- 1) Related issued patent: US Patent US8,067,973; US8,400,790. CN Patent ZL201010504140.4; ZL200910059751.X. Other patents pending.

### TYPICAL APPLICATION

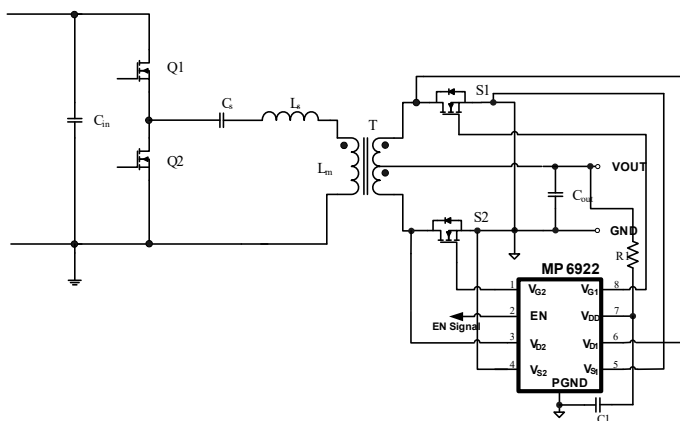

SOIC8E

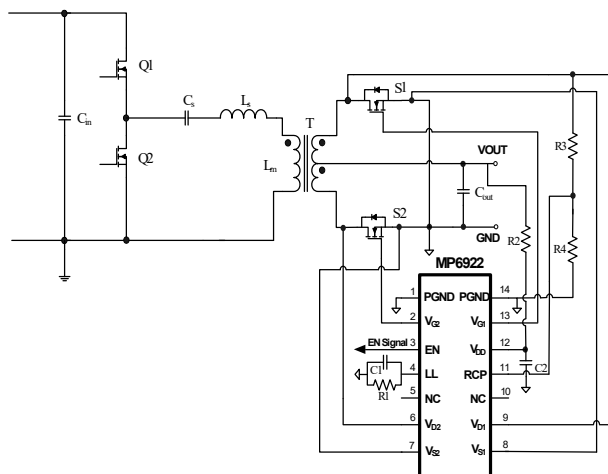

SOIC14

### ORDERING INFORMATION

Part Number	Package	Top Marking
MP6922DN*	SOIC8E	See Below
MP6922DS**	SOIC14	See Below
MP6922DSE***	SOIC8	See Below

\*For Tape & Reel, add suffix -Z (e.g. MP6922DN-Z);  
 For RoHS Compliant Packaging, add suffix -LF; (e.g. MP6922DN-LF-Z)

\*\*For Tape & Reel, add suffix -Z (e.g. MP6922DS-Z);  
 For RoHS Compliant Packaging, add suffix -LF; (e.g. MP6922DS-LF-Z)

\*\*\*For Tape & Reel, add suffix -Z (e.g. MP6922DSE-Z);  
 For RoHS Compliant Packaging, add suffix -LF; (e.g. MP6922DSE-LF-Z)

### TOP MARKING (MP6922DN &MP6922DSE)

MP6922  
 LLLLLLLL  
 MPSYWW

MPS: MPS prefix  
 Y: year code  
 WW: week code  
 MP6922: part number  
 LLLLLLLL: lot number

### TOP MARKING (MP6922DS)

MPSYYWW  
 MP6922  
 LLLLLLLL

MPS: MPS prefix  
 YY: year code  
 WW: week code  
 MP6922: part number  
 LLLLLLLL: lot number

## PACKAGE REFERENCE

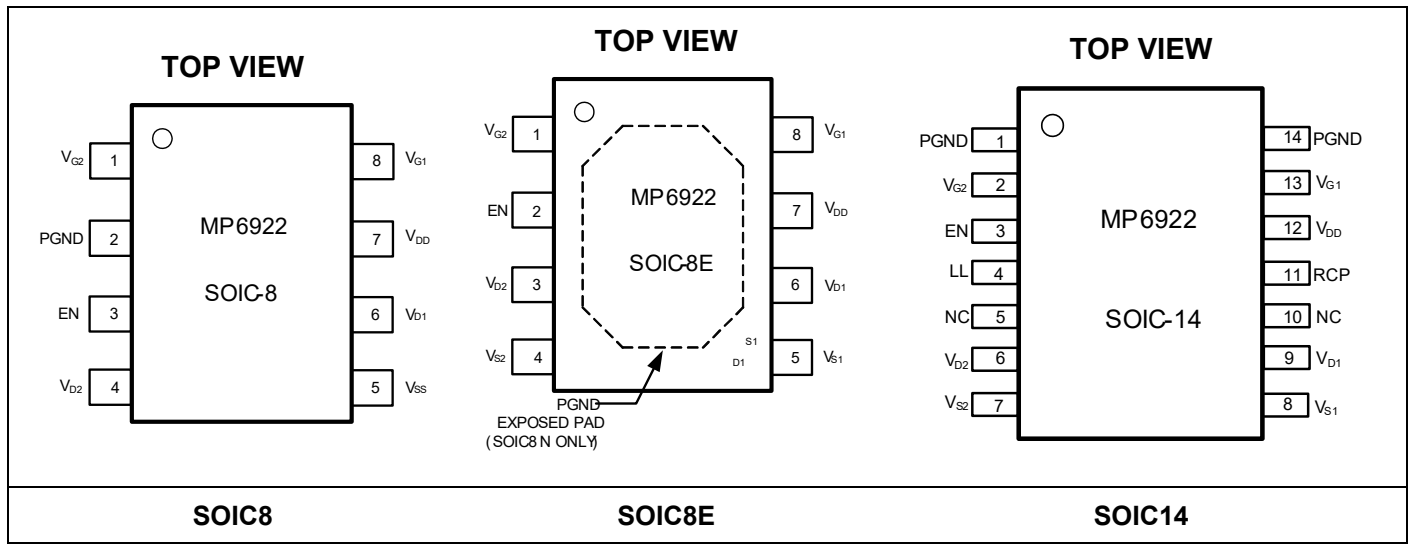

### ABSOLUTE MAXIMUM RATINGS <sup>(2)</sup>

V <sub>DD</sub> to V <sub>S1</sub> , V <sub>S2</sub> , V <sub>SS</sub> .....	-0.3V to +26V
PGND to V <sub>S1</sub> , V <sub>S2</sub> , V <sub>SS</sub> .....	-0.3V to +0.3V
V <sub>G1</sub> to V <sub>S1</sub> , V <sub>SS</sub> .....	-0.3V to V <sub>DD</sub>
V <sub>G2</sub> to V <sub>S2</sub> , V <sub>SS</sub> .....	-0.3V to V <sub>DD</sub>
V <sub>D1</sub> to V <sub>S1</sub> , V <sub>SS</sub> .....	-0.7V to +180V
V <sub>D2</sub> to V <sub>S2</sub> , V <sub>SS</sub> .....	-0.7V to +180V
LL, EN to V <sub>S1</sub> , V <sub>S2</sub> , V <sub>SS</sub> .....	-0.3V to +6.5V
Maximum Operating Frequency.....	300 kHz
Continuous Power Dissipation.. (T <sub>A</sub> = +25°C) <sup>(3)</sup>	
SOIC8E .....	2.5W
SOIC14 .....	1.5W
SOIC8 .....	1.4W
Junction Temperature .....	150°C
Lead Temperature (Solder).....	260°C
Storage Temperature .....	-55°C to +150°C

### Recommended Operation Conditions <sup>(4)</sup>

V <sub>DD</sub> to V <sub>S1</sub> , V <sub>S2</sub> , V <sub>SS</sub> .....	8V to 24V
Operating Junction Temp. (T <sub>J</sub> )....	-40°C to +125°C

### Thermal Resistance <sup>(4)</sup>

	$\theta_{JA}$	$\theta_{JC}$
SOIC8 .....	90	45
SOIC8E .....	50	10
SOIC14 .....	86	38

#### Notes:

- 2) Exceeding these ratings may damage the device.
- 3) T<sub>A</sub>=+25°C. The maximum allowable power dissipation is a function of the maximum junction temperature T<sub>J</sub>(MAX), the junction-to-ambient thermal resistance  $\theta_{JA}$ , and the ambient temperature T<sub>A</sub>. The maximum allowable continuous power dissipation at any ambient temperature is calculated by P<sub>D</sub>(MAX) = (T<sub>J</sub>(MAX)-T<sub>A</sub>)/ $\theta_{JA}$ . Exceeding the maximum allowable power dissipation will cause excessive die temperature, and the regulator will go into thermal shutdown. Internal thermal shutdown circuitry protects the device from permanent damage.
- 4) The device is not guaranteed to function outside of its operating conditions.
- 5) Measured on JESD51-7, 4-layer PCB. Without heatsink.

## ELECTRICAL CHARACTERISTICS

$V_{DD} = 12V$ ,  $T_A = +25^\circ C$ , unless otherwise noted.

Parameter	Symbol	Conditions	Min	Typ	Max	Units
$V_{DD}$ Voltage Range			8		24	V
$V_{DD}$ UVLO Threshold		Rising	5.0	6.0	7.0	V
		Hysteresis	0.5	1	1.5	V
Quiescent Current	$I_q$	$V_{D1}-V_{S1}=-0.5V$ , $V_{D2}-V_{S2}=-0.5V$		4	6	mA
Shutdown Current		$V_{DD}=20V$ , $EN=0V$			600	$\mu A$
Light-load Mode Current					600	$\mu A$
Thermal shutdown <sup>(6)</sup>				150		$^\circ C$
Thermal Shutdown hysteresis <sup>(6)</sup>				30		$^\circ C$
Enable Shutdown Threshold		Rising	1.1	1.5	1.9	V
		Hysteresis		0.2	0.4	V
Enable UVLO Threshold		Rising	2.5	3	3.5	V
		Hysteresis		0.2		V
Internal Pull-up Current on EN				10	15	$\mu A$
<b>CONTROL CIRCUITRY SECTION</b>						
$V_{S1,2} - V_{D1,2}$ forward voltage	$V_{fwd}$		55	70	85	mV
Turn-on delay	$T_{Don}$	$C_{LOAD} = 5nF$		150		ns
	$T_{Don}$	$C_{LOAD} = 10nF$		250		ns
Input bias current on $V_{D1,2}$ pin		$V_{D1,2} = 180V$			1	$\mu A$
Minimum on-time	$T_{MIN}$	$C_{LOAD} = 5nF$		1		$\mu s$
Minimum off-time	$T_{OFF}$			1.6		$\mu s$
Light-load-enter delay	$T_{LL-Delay}$	$R_{LL}=100k\Omega$		120	150	$\mu s$
Light-load-enter pulse width	$T_{LL}$	$R_{LL}=100k\Omega$		2.2		$\mu s$
Light-load turn on pulse width hysteresis	$T_{LL-H}$	$R_{LL}=100k\Omega$		0.2		$\mu s$
Light-load-enter off period width	$T_{LL-OFF}$	$R_{LL}=100k\Omega$		50		$\mu s$
Light-load mode exit pulse width threshold ( $V_{D1,2}-V_{S1,2}$ )	$V_{LL-DS}$		-400	-250		mV
Light-load mode enter pulse width threshold ( $V_{G1,2}-V_{S1,2}$ ) <sup>(6)</sup>	$V_{LL-GS}$			1.0		V
Reverse Current Protection threshold	$V_{RCP}$			3		V
Reverse Current Protection latch time	$T_{RCP}$			100		$\mu s$
<b>GATE DRIVER SECTION</b>						
$V_{G1,2}$ (Low)		$I_{LOAD}=1mA$		0.05	0.1	V
$V_{G1,2}$ (High)		$V_{DD} > 16V$		14		V
		$V_{DD} < 16V$		$V_{DD}-2.2$		
Turn off threshold ( $V_{S1,2}-V_{D1,2}$ ) <sup>(6)</sup>				-30		mV
Turn-off propagation delay		$V_{D1,2}=V_{SS}$		15		ns
Turn-off total delay	$T_{Doff}$	$V_{D1,2} = V_{SS}$ , $C_{LOAD}=5nF$ , $R_{GATE}=0\Omega$		35		ns
	$T_{Doff}$	$V_{D1,2} = V_{SS}$ , $C_{LOAD}=10nF$ , $R_{GATE}=0\Omega$		45		ns
Pull down impedance				1	2	$\Omega$
Pull down current <sup>(6)</sup>		$3V < V_{G1,2} < 10V$		3		A

6) Guaranteed by Design and Characterization

**PIN FUNCTIONS**

Pin # (SOIC8)	Pin # (SOIC8E)	Pin # (SOIC14)	Name	Description
1	1	2	V <sub>G2</sub>	FET 2 gate driver output
3	2	3	EN	Enable Pin. When EN pin voltage is larger than EN Shutdown threshold, the internal logic of the IC is start but the gate driver will be latched until the EN pin voltage has exceed the EN UVLO threshold
4	3	6	V <sub>D2</sub>	FET 2 drain voltage sense
-	4	7	V <sub>S2</sub>	Source pin used as reference for V <sub>D2</sub>
-	5	8	V <sub>S1</sub>	Source pin used as reference for V <sub>D1</sub>
6	6	9	V <sub>D1</sub>	FET 1 drain voltage sense
7	7	12	V <sub>DD</sub>	Supply Voltage
8	8	13	V <sub>G1</sub>	FET 1 gate driver output
2	EXPOSE D PAD	1,14	PGND	Power Ground, return for power switch
-	-	5,10	NC	No Connection
-	-	4	LL	Light load timing setting. Connect a resistor to set the light load timing
-	-	11	RCP	Reverse Protection function, internal 5V reference.
5	-	-	V <sub>SS</sub>	Common source pin used as reference for both channels

## TYPICAL PERFORMANCE CHARACTERISTICS

$V_{DD} = 12V$ , unless otherwise noted.

**$V_{D1,2}$  Breakdown Voltage vs. Temperature**

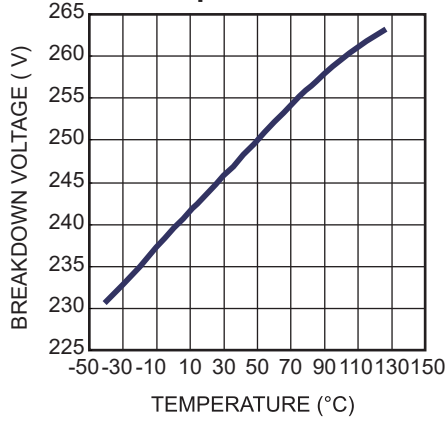

**VDD UVLO Rising vs. Temperature**

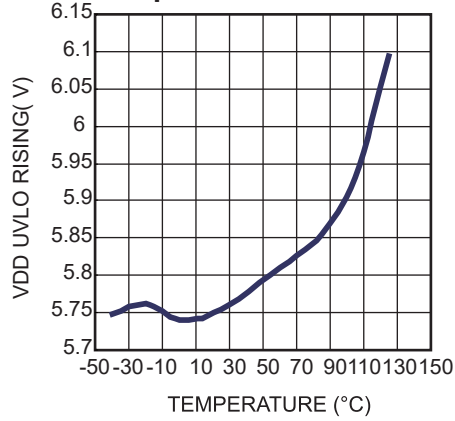

**Quiescent Current vs. Temperature**

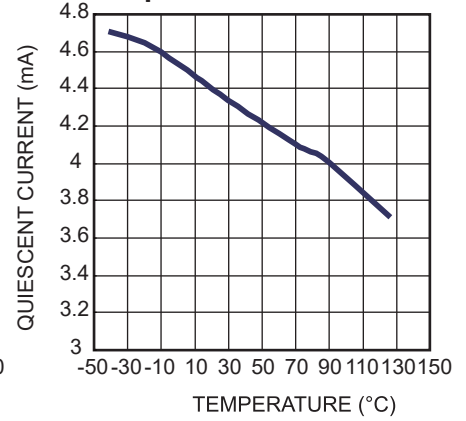

**Shutdown Current (VDD=20V) vs. Temperature**

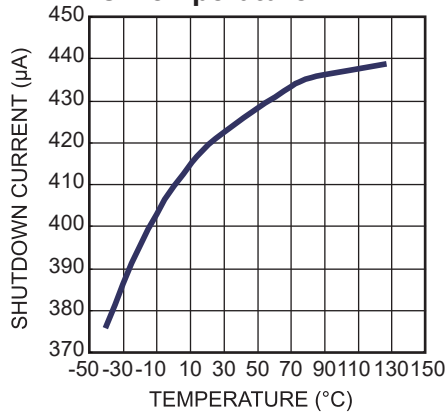

**Vfwd vs. Temperature**

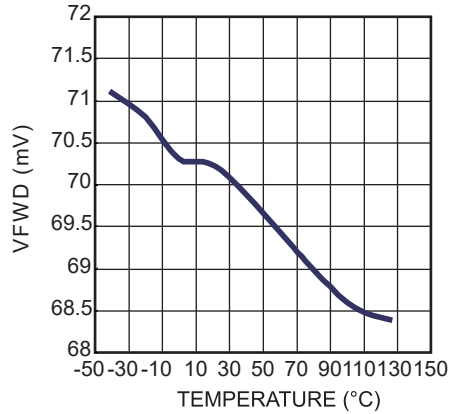

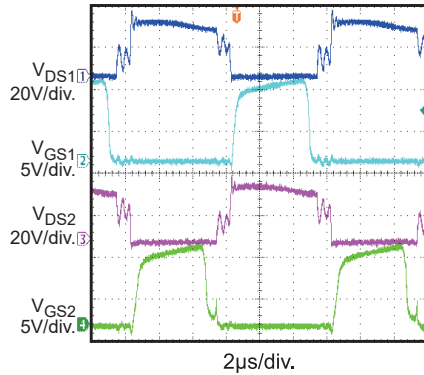
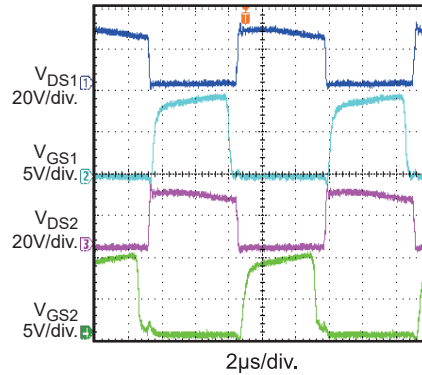
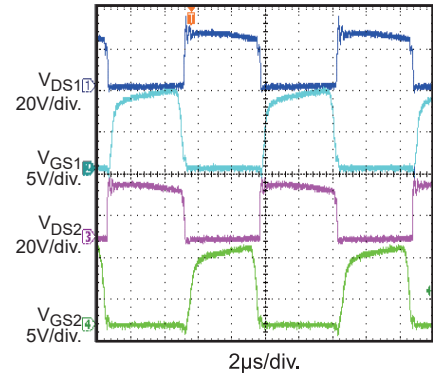
**TYPICAL PERFORMANCE CHARACTERISTICS** *(continued)*
 **$V_{DD} = 12V$ , unless otherwise noted.**
**Operation in 180W LLC Converter**
 $V_{IN}=220Vac, V_{OUT}=12V, I_{OUT}=15A$ 

**Operation in 180W LLC Converter**
 $V_{IN}=240Vac, V_{OUT}=12V, I_{OUT}=15A$ 

**Operation in 180W LLC Converter**
 $V_{IN}=260Vac, V_{OUT}=12V, I_{OUT}=15A$ 

## BLOCK DIAGRAM

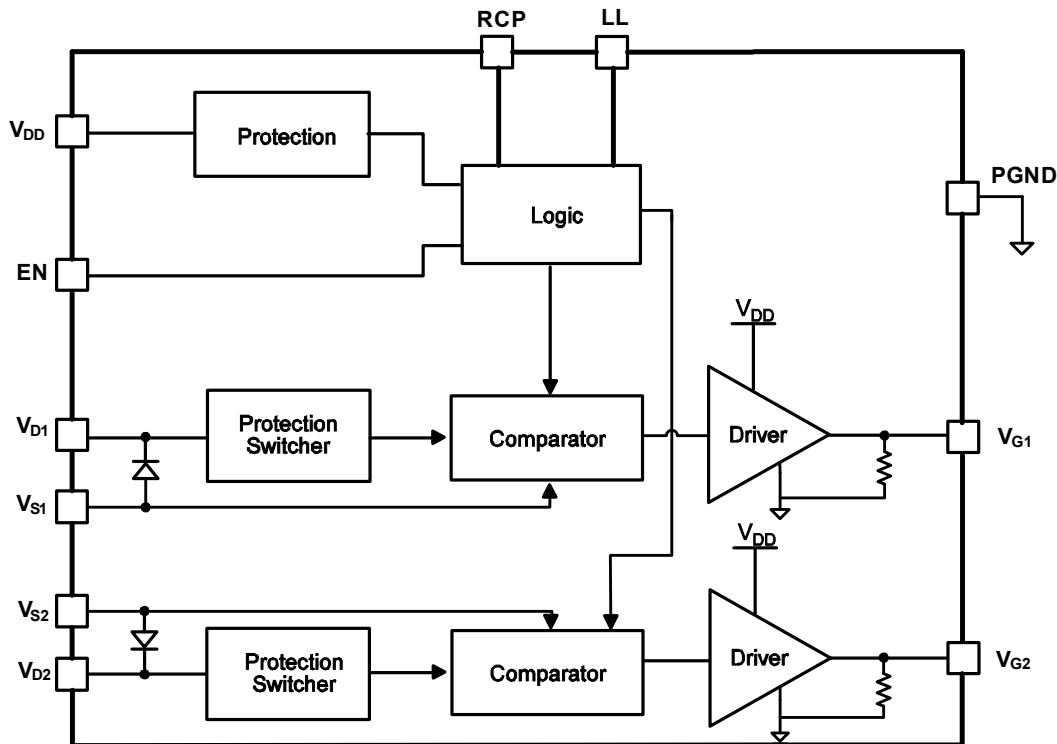

Figure 1—Functional Block Diagram

## OPERATION

The MP6922 supports operation in DCM, CCM and CrCM condition. Operating in either a DCM or CrCM condition, the control circuitry controls the gate in forward mode and will turn the gate off when the MOSFET current is fairly low. In CCM operation, the control circuitry turns off the gate when very fast transients occur.

### Blanking

The control circuitry contains blanking function. When it pulls the MOSFET on/off, it makes sure that the on/off state at least lasts for some time. The turn on blanking time is  $\sim 1\mu\text{s}$ , which determines the minimum on-time. During the turn on blanking period, the turn off threshold is not totally blanked, but changed to  $\sim +100\text{mV}$  (instead of  $30\text{mV}$ ). This assures that the part can always be turned off even during the turn on blanking period. (Albeit slower, so it is not recommended to set the synchronous period less than  $1\mu\text{s}$  at

CCM condition in LLC converter, otherwise shoot through may occur)

### VD Clamp

Because  $V_{D1,2}$  can go as high as  $180\text{V}$ , a High-Voltage JFET is used at the input. To avoid excessive currents when  $V_g$  goes below  $-0.7\text{V}$ , a small resistor is recommended between  $V_{D1,2}$  pin and the drain of the external MOSFET.

### Under-Voltage Lockout (UVLO)

When  $V_{DD}$  is below UVLO threshold, the part falls into sleep mode and  $V_g$  is pulled down by a  $10\text{k}\Omega$  resistor.

### Enable pin

If EN is pulled low, the part is in sleep mode.

### Thermal shutdown

If the junction temperature of the IC exceeds  $150^\circ\text{C}$ ,  $V_g$  will be pulled low and the part



stops switching. The part will return to normal operation after the junction temperature has dropped to 120°C.

**Turn-on Phase**

When the switch current flows through the body diode of the MOSFET, there will be a negative  $V_{DS}$  ( $V_D - V_{SS}$ ) across it ( $< -500mV$ ), the  $V_{DS}$  is much lower than the turn on threshold of the control circuitry ( $-70mV$ ), which then turns on the MOSFET after 200ns turn-on delay (defined in Fig.2).

As soon as the turn on threshold ( $-70mV$ ) is triggered, a blanking time (Minimum on-time:  $\sim 1\mu s$ ) will be added during which the turn off threshold will be changed from  $0mV$  to  $+50mV$ . This blanking time can help to avoid error trigger on turn off threshold caused by the turn on ringing of the synchronous power switch.

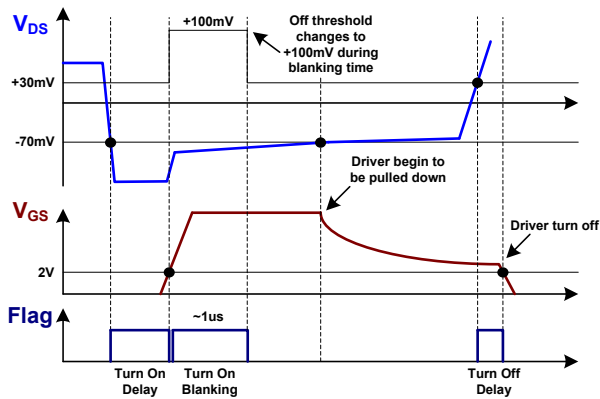

**Figure 2—Turn on and Turn off delay**

**Conducting Phase**

When the MOSFET is turned on,  $V_{DS}$  ( $-I_{SD} \times r_{DS(ON)}$ ) becomes to rise according to the drop of the switch current ( $I_{SD}$ ), as soon as  $V_{DS}$  rises above the turn on threshold ( $-70mV$ ), the control circuitry stops pulling up the gate driver and the driver voltage of the MOSFET dropped, which makes the on resistance  $r_{DS(ON)}$  of the MOSFET becomes larger. By doing that,  $V_{DS}$  ( $-I_{SD} \times r_{DS(ON)}$ ) is adjusted to be around  $-70mV$  even when the switch current  $I_{SD}$  is fairly small, this function can make the turn off threshold ( $0mV$ ) of the internal driver never triggered until the current through the MOSFET has dropped to near zero.

**Turn-off Phase**

When  $V_{DS}$  rises to trigger the turn off threshold ( $30mV$ ), the driver voltage of the switch is pulled to

low after about 20ns turn off delay (defined in Fig.4) by the control circuitry. Similar with turn-on phase, a 1.6 $\mu s$  blanking time is added after the switch is turned off, during which the MOSFET is never turned on to avoid error trigger.

Fig.3 show the MP6922 operation at heavy load condition. Due to the high current, the driver voltage will be saturated at first. After  $V_{DS}$  goes to above  $-70mV$ , driver voltage decreases to adjust the  $V_{DS}$  to typical  $-70mV$ .

Fig.4 show the MP6922 operation at light load condition. Due to the low current, the driver voltage never saturates but begins to decrease as soon as the synchronous power switch is turned on and adjust the  $V_{DS}$ .

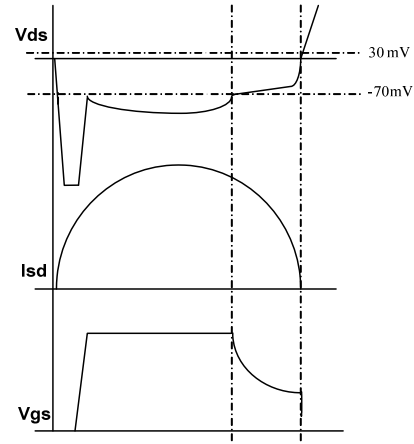

**Figure 3—Synchronous Rectification Operation at heavy load**

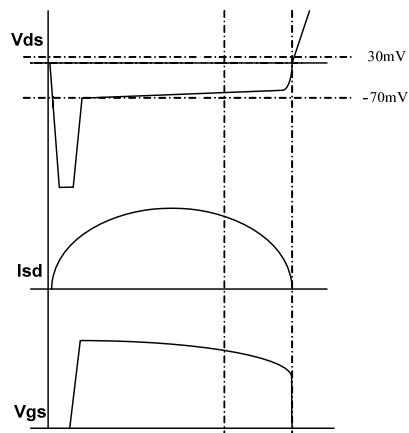

**Figure 4—Synchronous Rectification Operation at light load**

### Light-load Latch-off Function

The gate driver of MP6922 is latched to save the driver loss at light-load condition to improve light load efficiency.

### Latch off during Normal Operation

When the MOSFET conducting period during each switching cycle keeps lower than 2.2us ( $T_{LL}$ ), the MP6922 falls into light-load mode and latches off the MOSFET after 120us delay (light-load-enter delay,  $T_{LL-Delay}$ )

After falling into light-load mode, MP6922 monitors the MOSFET's body diode conducting period by sensing  $V_{DS}$  (when  $V_{DS}$  exceeds -250mV ( $V_{LL-DS}$ ), MP6922 considers the MOSFET's body diode conducting period finishes). If the MOSFET's body diode conducting period is longer than  $\sim 2.4\mu s$  ( $T_{LL}+T_{LL-H}$ ), the light-load mode is finished and the MOSFET is unlatched to restart the synchronous rectification.

For SOIC14 package MP6922 with LL pin, the  $T_{LL}$  could be adjusted by an external resistor:

$$T_{LL} = 2.2\mu s \cdot \frac{R_{LL}}{100k\Omega}$$

### Latch off during Burst Operation

The IC also monitors the synchronous MOSFET off period, if the off period is longer than the light-load-enter off period width ( $T_{LL-OFF}$ ), MP6922 enters light-load mode and latches off the gate driver.

The gate driver is unlatched when the drain-source voltage of the synchronous MOSFET  $V_{DS}$  drops below -70mV.

### Reverse Current Protection Function

When the LLC system operates in CCM with very high frequency, the synchronous current may get reverse before the IC turns off the gate driver which leads to shoot through (in center-tapped output with full-wave rectification topology). MP6922 has protection function to latch off the gate driver when the current reverses before the driver signal is pulled low.

When the synchronous current reverses, the high spike can be observed between Drain-Source of MOSFET. The MP6922 monitors the voltage by RCP pin through a voltage divider. When the voltage of RCP pin exceeds  $V_{RCP}$ , MP6922 will latch the driver signal of both channels for  $\sim 100\mu s$  ( $T_{RCP}$ ) to protect the synchronous MOSFET. At the end of  $T_{RCP}$ , MP6922 restarts the synchronous rectification.

TYPICAL APPLICATION CIRCUIT

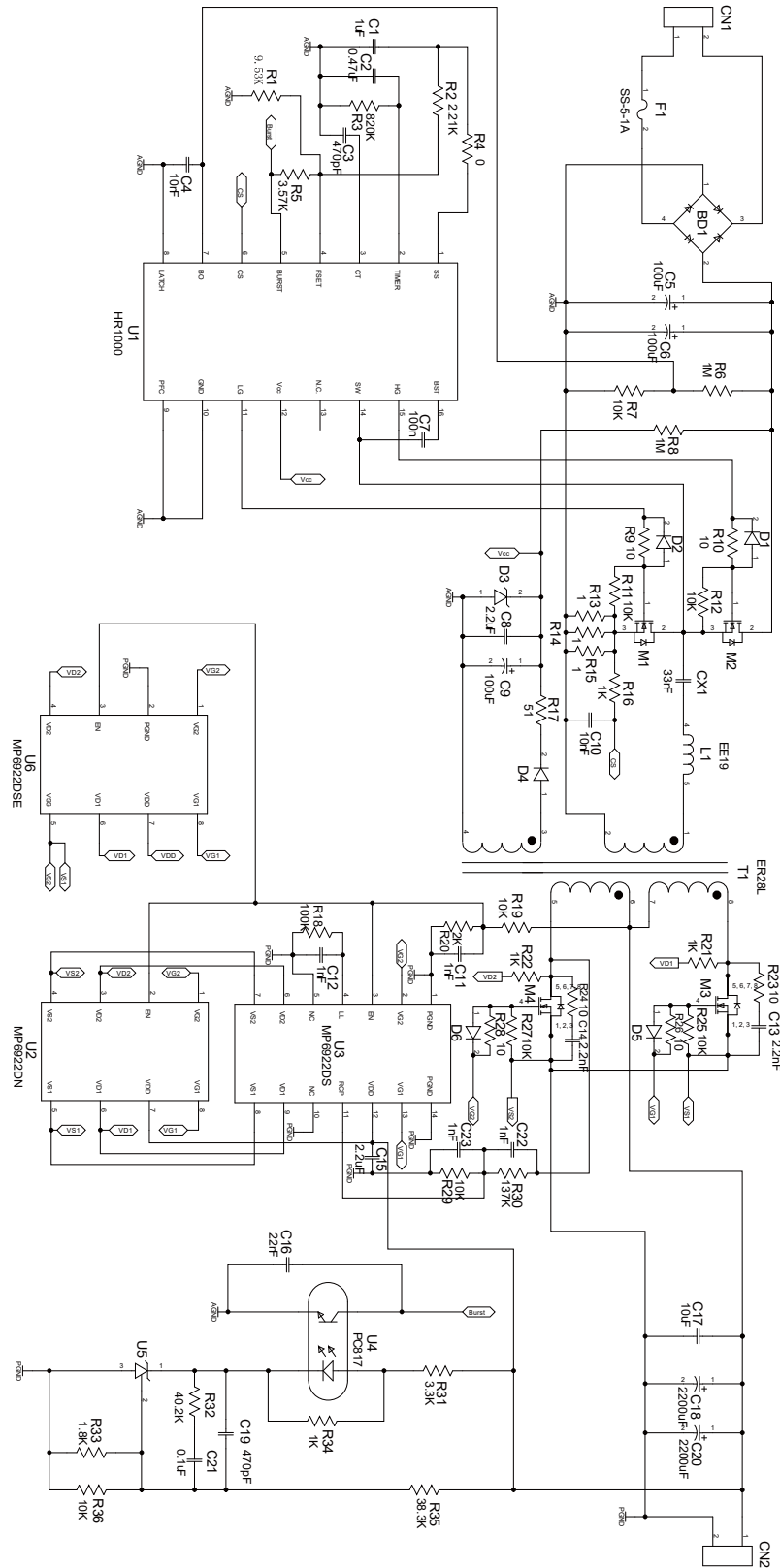
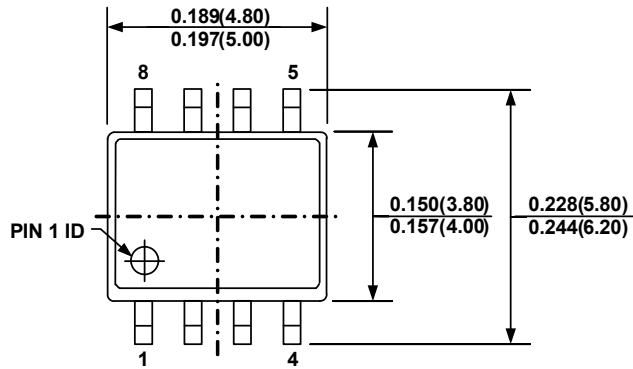

Figure 5—Synchronous Rectification in LLC with MP6922

## PACKAGE INFORMATION

### SOIC8E (EXPOSED PAD)



**TOP VIEW**

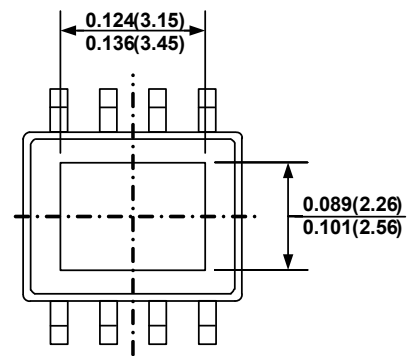

**BOTTOM VIEW**

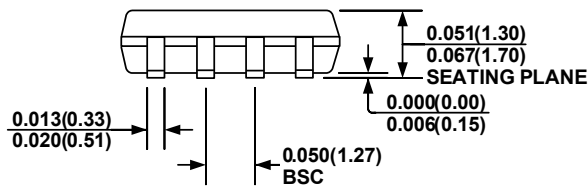

**FRONT VIEW**

SEE DETAIL "A"

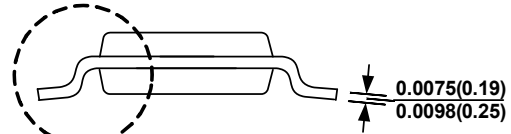

**SIDE VIEW**

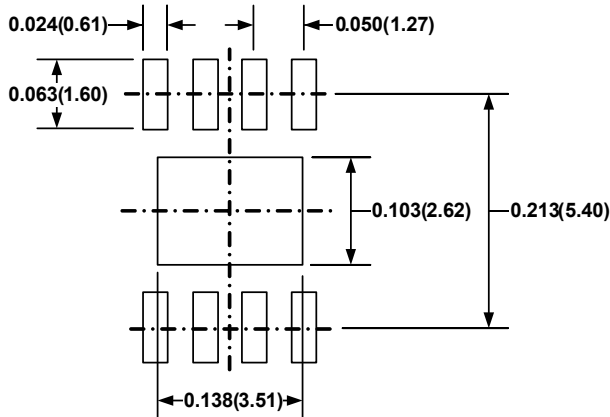

**RECOMMENDED LAND PATTERN**

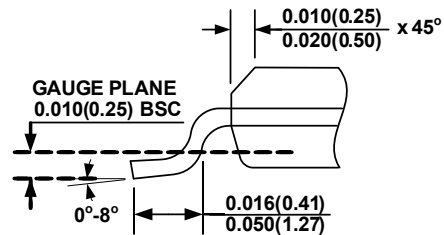

**DETAIL "A"**

**NOTE:**

- 1) CONTROL DIMENSION IS IN INCHES DIMENSION IN BRACKET IS IN MILLIMETERS
- 2) PACKAGE LENGTH DOES NOT INCLUDE MOLD FLASH, PROTRUSIONS OR GATE BURRS
- 3) PACKAGE WIDTH DOES NOT INCLUDE INTERLEAD FLASH OR PROTRUSIONS.
- 4) LEAD COPLANARITY(BOTTOM OF LEADS AFTER FORMING) SHALL BE 0.004" INCHES MAX.
- 5) DRAWING CONFORMS TO JEDEC MS012, VARIATION BA
- 6) DRAWING IS NOT TO SCALE

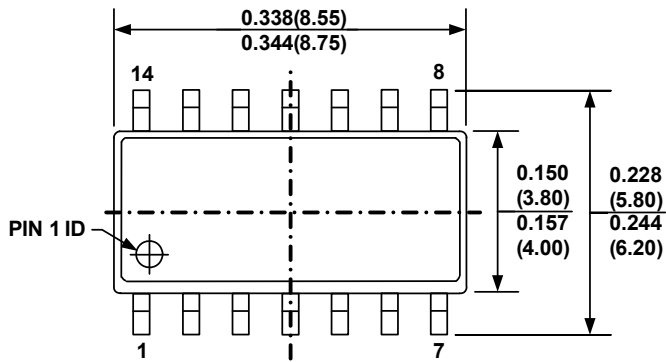
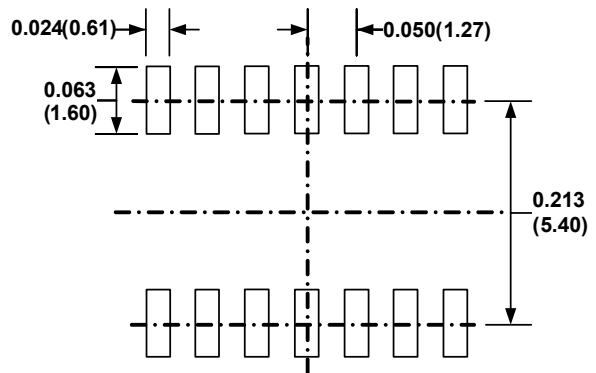
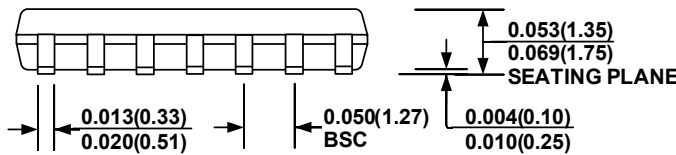
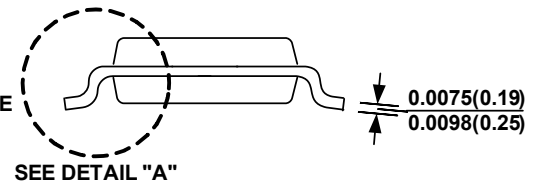
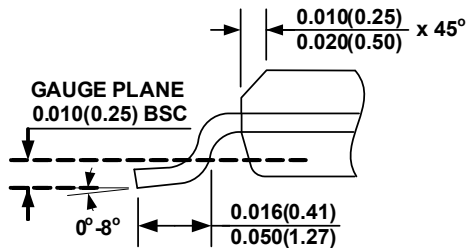
**SOIC14**

**TOP VIEW**

**RECOMMENDED LAND PATTERN**

**FRONT VIEW**

**SIDE VIEW**

**DETAIL "A"**
**NOTE:**

- 1) CONTROL DIMENSION IS IN INCHES DIMENSION IN BRACKET IS IN MILLIMETERS
- 2) PACKAGE LENGTH DOES NOT INCLUDE MOLD FLASH, PROTRUSIONS OR GATE BURRS
- 3) PACKAGE WIDTH DOES NOT INCLUDE INTERLEAD FLASH OR PROTRUSIONS.
- 4) LEAD COPLANARITY(BOTTOM OF LEADS AFTER FORMING) SHALL BE 0.004" INCHES MAX.
- 5) DRAWING CONFORMS TO JEDEC MS012, VARIATION AB.
- 6) DRAWING IS NOT TO SCALE