



PF7100

7-channel power management integrated circuit for high performance applications

Rev. 4 — 9 March 2021

Product data sheet

1 Overview

The PF7100 is a power management integrated circuit (PMIC) designed for high performance i.MX 8 processors. It features five high efficiency buck converters and two linear regulators for powering the processor, memory, and miscellaneous peripherals.

Built-in one-time programmable memory stores key startup configurations, drastically reducing external components typically used to set output voltage and sequence of external regulators. Regulator parameters are adjustable through high-speed I²C after startup offering flexibility for different system states.

2 Features

- Five high efficiency buck converters
- Two linear regulators with load switch options
- Watchdog timer/monitor
- Monitoring circuit to fit ASIL B safety level
- One-time programmable device configuration
- 3.4 MHz I²C communication interface
- 48-pin 7×7 mm QFN package

3 Simplified application diagram

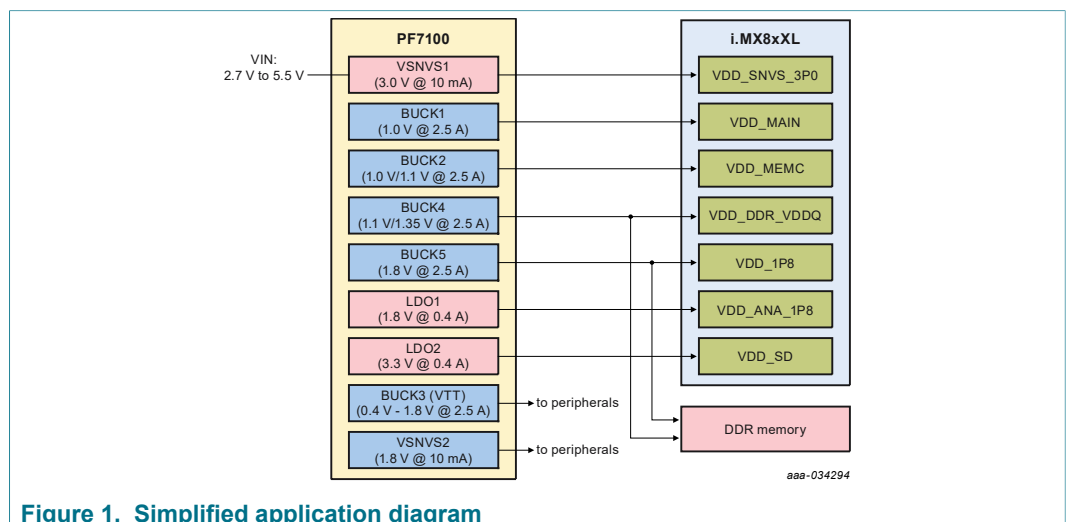

7-channel power management integrated circuit for high performance applications

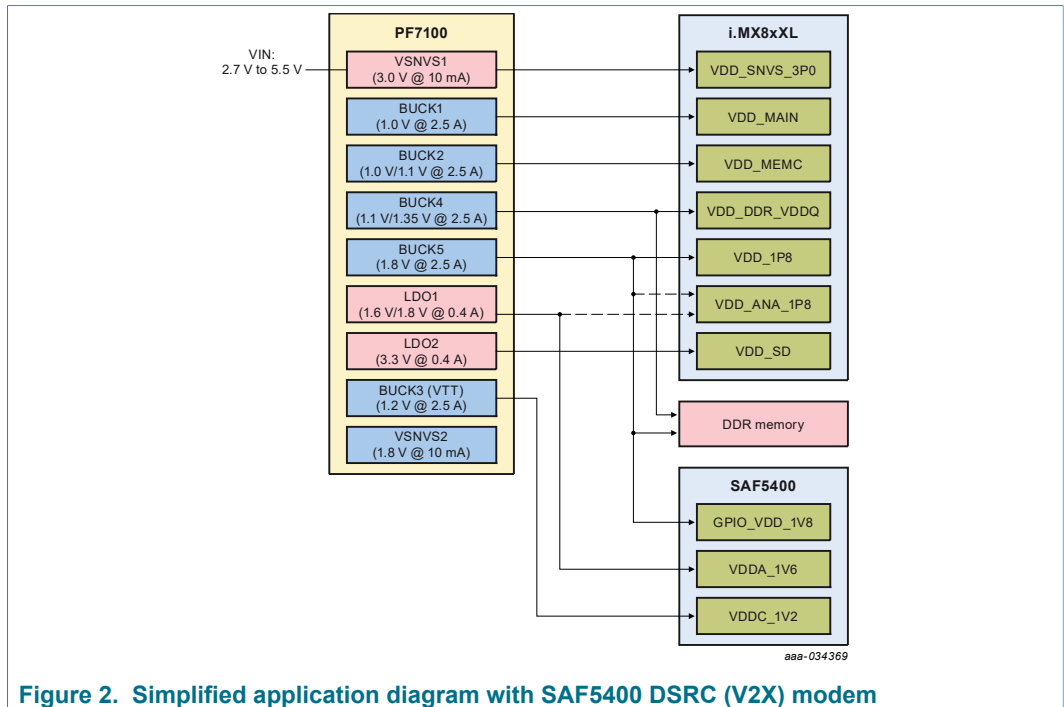

Figure 2. Simplified application diagram with SAF5400 DSRC (V2X) modem

4 Ordering information

Table 1. Device information

Type	Package		
	Name	Description	Version
PF7100 (automotive and industrial)	HVQFN48	HVQFN48, plastic, thermally enhanced very thin quad; flat non-leaded package, dimple wettable flanks; 48 pins; 0.5 mm pitch; 7 mm x 7 mm x 0.85 mm body	SOT619-27(D)

Table 2. Ordering information

Part number ^[1]	Target market	Process or	System comments	AEC-Q100 grade ^[2]	Safety grade	OTP ID
MPF7100BMA0ES	Automotive	—	OTP not programmed	1	ASIL B	A0
MPF7100BVBA0ES	Automotive	—	OTP not programmed	2	ASIL B	A0
MPF7100BMA0ES	Automotive	—	OTP not programmed	1	QM	A0
MPF7100BVMA0ES	Automotive Industrial	—	OTP not programmed	2	QM	A0
MPF7100BVBA1ES	Automotive	i.MX8XL	LPDDR4 memory	2	ASIL B	http://www.nxp.com/MPF7100BVBA1ES-OTP-Report
MPF7100BVMA1ES	Automotive Industrial	i.MX8XL	LPDDR4 memory	2	QM	http://www.nxp.com/MPF7100BVMA1ES-OTP-Report
MPF7100BVBA2ES	Automotive	i.MX8XL	DDR3L memory	2	ASIL B	http://www.nxp.com/MPF7100BVBA2ES-OTP-Report
MPF7100BVMA2ES	Automotive Industrial	i.MX8XL	DDR3L memory	2	QM	http://www.nxp.com/MPF7100BVMA2ES-OTP-Report
MPF7100BVBA3ES	Automotive	i.MX8DXP i.MX8DX	LPDDR4 memory	2	ASIL B	http://www.nxp.com/MPF7100BVBA3ES-OTP-Report
MPF7100BVMA3ES	Automotive Industrial	i.MX8DXP i.MX8DX	LPDDR4 memory	2	QM	http://www.nxp.com/MPF7100BVMA3ES-OTP-Report
MPF7100BVBA4ES	Automotive	i.MX8DXP i.MX8DX	DDR3L memory	2	ASIL B	http://www.nxp.com/MPF7100BVBA4ES-OTP-Report
MPF7100BVMA4ES	Automotive Industrial	i.MX8DXP i.MX8DX	DDR3L memory	2	QM	http://www.nxp.com/MPF7100BVMA4ES-OTP-Report

[1] To order parts in tape and reel, add the R2 suffix to the part number.

[2] For the device ambient operating temperature range, see [Table 6](#).

5 Applications

- Automotive Infotainment
- Telematics
- High-end consumer and industrial

6 Internal block diagram

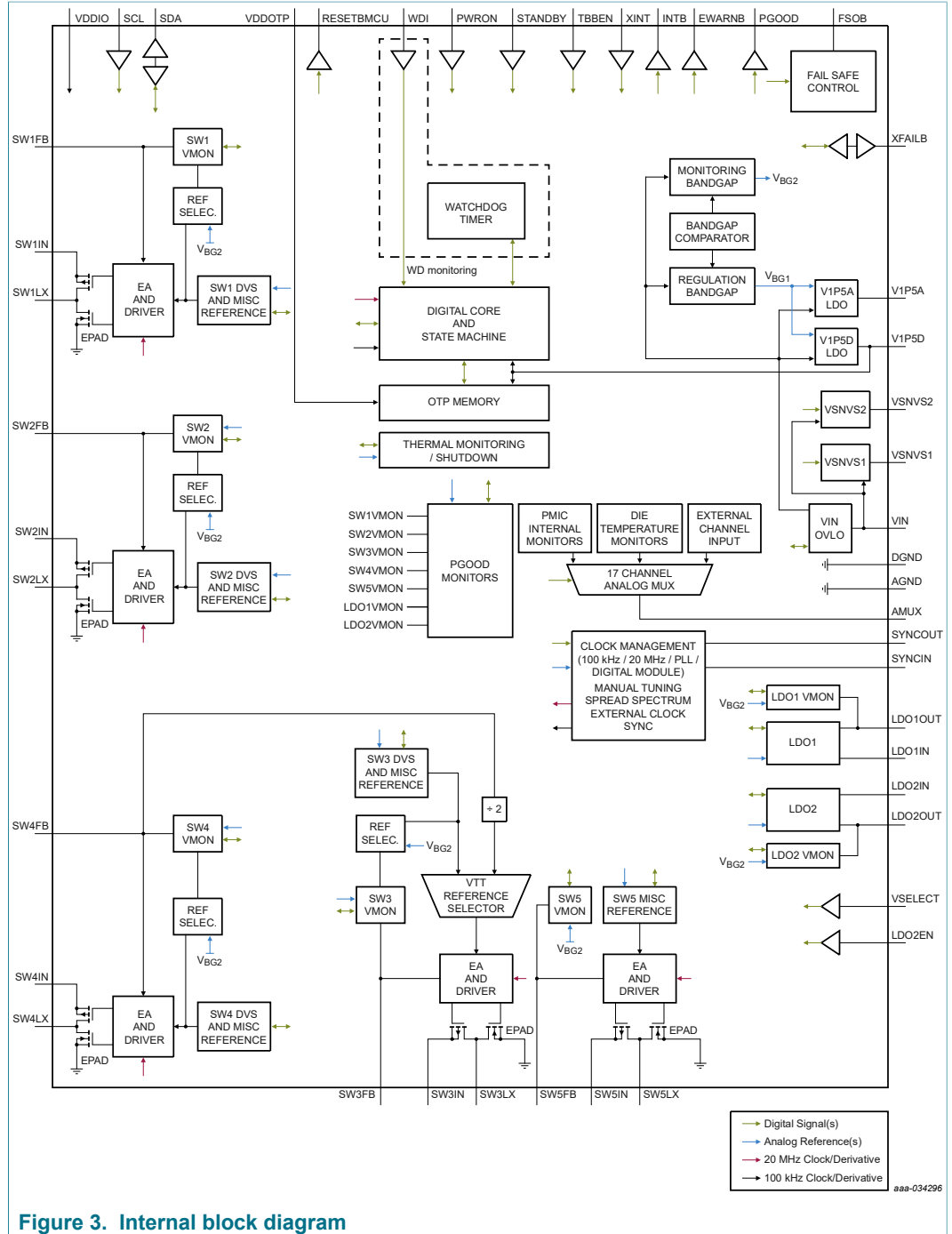

Figure 3. Internal block diagram

7 Pinning information

7.1 Pinning

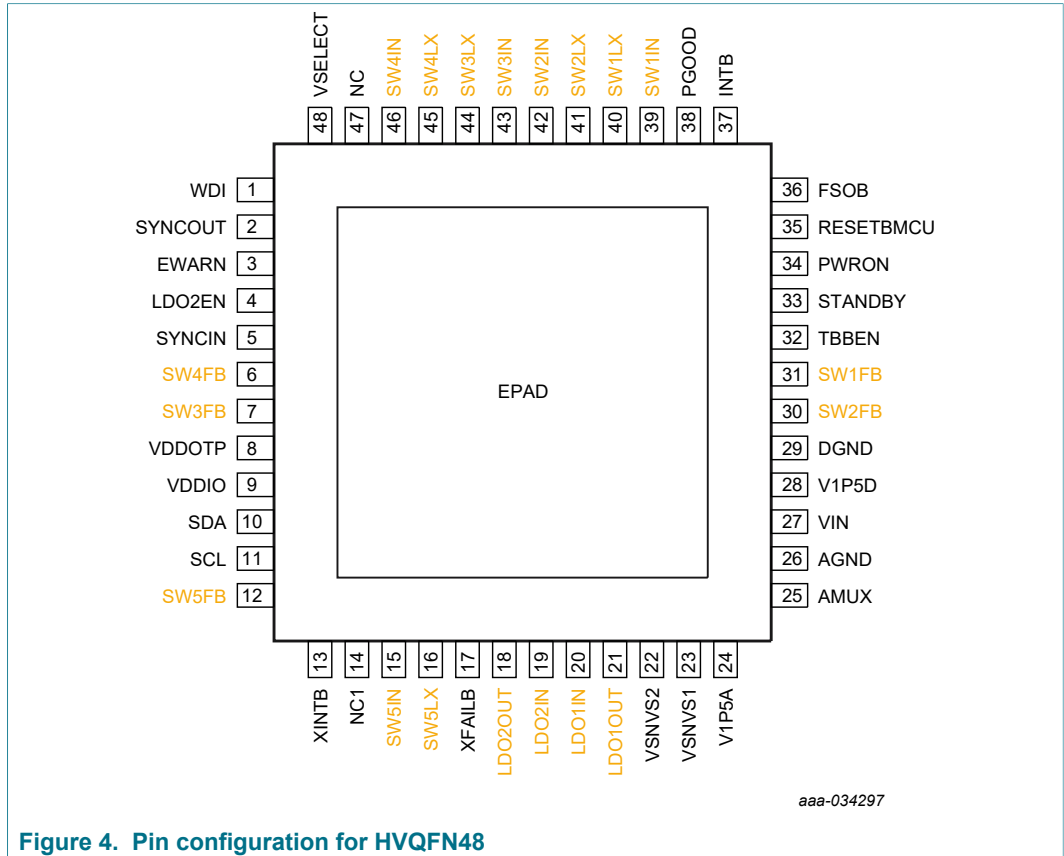

Figure 4. Pin configuration for HVQFN48

7.2 Pin definitions

Table 3. Pin definitions

Pin number	Symbol	Application description	Pin type	Min	Max	Units
1	WDI	Watchdog Input from MCU	I	-0.3	6.0	V
2	SYNCOUT	Clock out pin for external part synchronization	O	-0.3	6.0	V
3	EWARN	Early warning to MCU	O	-0.3	6.0	V
4	LDO2EN	LDO2 enable pin	I	-0.3	6.0	V
5	SYNCIN	External clock input pin for synchronization	I	-0.3	6.0	V
6	SW4FB	Buck 4 output voltage feedback	I	-0.3	6.0	V
7	SW3FB	Buck 3 output voltage feedback	I	-0.3	6.0	V
8	VDDOTP	OTP selection input	I	-0.3	10	V
9	VDDIO	I/O supply voltage. Connect to voltage rail between 1.6 V and 3.3 V.	I	-0.3	6.0	V
10	SDA	I ² C data signal	I/O	-0.3	6.0	V
11	SCL	I ² C clock signal	I	-0.3	6.0	V
12	SW5FB	Buck 5 output voltage feedback	I	-0.3	6.0	V
13	XINTB	External interrupt input	I	-0.3	6.0	V
14	NC1	Reserved	—	—	—	—
15	SW5IN	Buck 5 input supply	I	-0.3	6.0	V

7-channel power management integrated circuit for high performance applications

Pin number	Symbol	Application description	Pin type	Min	Max	Units
16	SW5LX	Buck 5 switching node	O	-0.3	6.0	V
17	XFAILB	External synchronization pin	I/O	-0.3	6.0	V
18	LDO2OUT	LDO2 output	O	-0.3	6.0	V
19	LDO2IN	LDO2 input supply	I	-0.3	6.0	V
20	LDO1IN	LDO1 input supply	I	-0.3	6.0	V
21	LDO1OUT	LDO1 output	O	-0.3	6.0	V
22	VSNVS2	VSNVS2 regulator output	O	-0.3	6.0	V
23	VSNVS1	VSNVS1 regulator output	O	-0.3	6.0	V
24	V1P5A	1.6 V analog core supply	O	-0.3	2.0	V
25	AMUX	Analog multiplexer output	O	-0.3	6.0	V
26	AGND	Analog ground	GND	-0.3	0.3	V
27	VIN	Main input voltage to PMIC	I	-0.3	6.0	V
28	V1P5D	1.6 V digital core supply	O	-0.3	2.0	V
29	DGND	Digital ground	GND	-0.3	0.3	V
30	SW2FB	Buck 2 feedback input	I	-0.3	6.0	V
31	SW1FB	Buck 1 feedback input	I	-0.3	6.0	V
32	TBBEN	Try before buy enable pin	I	-0.3	6.0	V
33	STANDBY	STANDBY input	I	-0.3	6.0	V
34	PWRON	PWRON input	I	-0.3	6.0	V
35	RESETBMCU	RESETBMCU open-drain output	O	-0.3	6.0	V
36	FSOB	Safety output pin	O	-0.3	6.0	V
37	INTB	INTB open-drain output	O	-0.3	6.0	V
38	PGOOD	PGOOD open-drain output	O	-0.3	6.0	V
39	SW1IN	Buck 1 input supply	I	-0.3	6.0	V
40	SW1LX	Buck 1 switching node	O	-0.3	6.0	V
41	SW2LX	Buck 2 switching node	O	-0.3	6.0	V
42	SW2IN	Buck 2 input supply	I	-0.3	6.0	V
43	SW3IN	Buck 3 input supply	I	-0.3	6.0	V
44	SW3LX	Buck 3 switching node	O	-0.3	6.0	V
45	SW4LX	Buck 4 switching node	O	-0.3	6.0	V
46	SW4IN	Buck 4 input supply	I	-0.3	6.0	V
47	NC	Reserved	—	—	—	—
48	VSELECT	LDO2 voltage select input	I	-0.3	6.0	V
49	EPAD	Exposed pad. Connect to ground.	GND	-0.3	0.3	V

8 Absolute maximum ratings

Table 4. Absolute maximum ratings

Symbol	Parameter	Min	Typ	Max	Unit
VIN	Main input supply voltage	[1] -0.3	—	6.0	V
SWxVIN, LDOxVIN	Regulator input supply voltage	[1] -0.3	—	6.0	V
VDDOTP	OTP programming input supply voltage	-0.3	—	10	V

[1] Pin reliability may be affected if system voltages are above the maximum operating range of 5.5 V for extended period of time. To minimize system reliability impact, system must not operate above 5.5 V for more than 1800 sec over the lifetime of the device.

9 ESD ratings

Table 5. ESD ratings

All ESD specifications are compliant with AEC-Q100 specification.

Symbol	Parameter	Min	Typ	Max	Unit
V _{ESD}	Human Body Model [1]	—	—	2000	V
V _{ESD}	Charge Device Model [1] QFN package - all pins	—	—	500	V
I _{LATCHUP}	Latch-up current	—	—	100	mA

[1] ESD testing is performed in accordance with the human body model (HBM) (CZAP = 100 pF, RZAP = 1500 Ω), and the charge device model (CDM), robotic (CZAP = 4.0 pF)

10 Thermal characteristics

Table 6. Thermal characteristics

Symbol	Parameter	Min	Typ	Max	Unit
T _A	Ambient operating temperature AEC-Q100 grade 1	-40	—	125	°C
T _A	Ambient operating temperature AEC-Q100 grade 2	-40	—	105	°C
T _J	Junction temperature	-40	—	150	°C
T _{ST}	Storage temperature range	-55	—	150	°C
T _{PPRT}	Peak package reflow temperature	—	—	260	°C

Table 7. HVQFN48 thermal resistance and package dissipation ratings

Symbol	Parameter	Min	Max	Unit
R _{θJA}	Junction to ambient thermal resistance [1] [2] [3] Four layer board (2s2p)	—	35	°C/W
R _{θJA}	Junction to ambient thermal resistance [1] [2] [4] Eight layer board (2s6p)	—	22	°C/W
Ψ _{JT}	Junction-to-top of package thermal resistance [1] [2] [3] Four layer board(2s2p)	—	1.0	°C/W
Ψ _{JT}	Junction-to-top of package thermal resistance [1] [2] [4] Eight layer board(2s6p)	—	1.0	°C/W

[1] Determined in accordance to JEDEC JESD51-2A natural convection environment and uniform power.

[2] Thermal resistance data in this report is solely for a thermal performance comparison of one package to another in a standardized specified environment. It is not meant to predict the performance of a package in an application-specific environment.

[3] Thermal test board meets JEDEC specification for this package (JESD51-9, 2s2p).

[4] 2s6p PCB is with customized board layers (top and bottom metal layers are at 7 μm thickness, internal metal layers are at 35 μm thickness).

11 Operating conditions

Table 8. Operating conditions

Symbol	Parameter	Min	Typ	Max	Unit
V _{IN}	Main input supply voltage	UVDET	—	5.5	V

12 General description

12.1 Features

The PF7100 is a power management integrated circuit (PMIC) designed to be the primary power management building block for NXP high-end multimedia application processors from the i.MX 8 series. It is also capable of providing power solution to the high end i.MX 6 series as well as several non-NXP processors.

- Buck regulators
 - SW1, SW2, SW3, SW4: 0.4 V to 1.8 V; 2500 mA; 2 % accuracy
 - SW5: 1.0 V to 4.1 V; 2500 mA; 2 % accuracy
 - Dynamic voltage scaling on SW1, SW2, SW3, SW4,
 - SW1, SW2 configurable as a dual phase regulator
 - SW3, SW4 configurable as a dual phase regulator
 - SW1, SW2, and SW3 configurable as a triple phase regulator with up to 7.5 A current capability
 - SW1, SW2, SW3, and SW4 configurable as a quad phase regulator with up to 10 A current capability
 - VTT termination mode on SW3
 - Programmable current limit
 - Spread-spectrum and manual tuning of switching frequency
- LDO regulators
 - LDO1, 0.8 V to 5.0 V, 400 mA; 3 % accuracy with optional load switch mode
 - LDO2, 0.8 V to 5.0 V, 400 mA; 3 % accuracy with optional load switch mode and selectable hardware/software control
- 2 RTC LDO supply
 - VSNVS1, 1.8 V/3.0 V/3.3 V, 10 mA
 - VSNVS2, 0.8 V/0.9 V/1.8 V, 10 mA
- System features
 - Fast PMIC startup
 - Advanced state machine for seamless processor interface
 - High speed I²C interface support (up to 3.4 MHz)
 - PGOOD monitor
 - User programmable standby and off modes
 - Programmable soft start sequence and power down sequence
 - Programmable regulator configuration
 - Analog multiplexer for smart system monitoring/diagnostic
- OTP (one-time programmable) memory for device configuration
- Monitoring circuit to fit ASIL B safety level
 - Independent voltage monitoring with programmable fault protection
 - Advance thermal monitoring and protection
 - External watchdog monitoring and programmable internal watchdog counter
 - I²C CRC and write protection mechanism
 - Analog built-in self-test (ABIST)

12.2 Functional block diagram

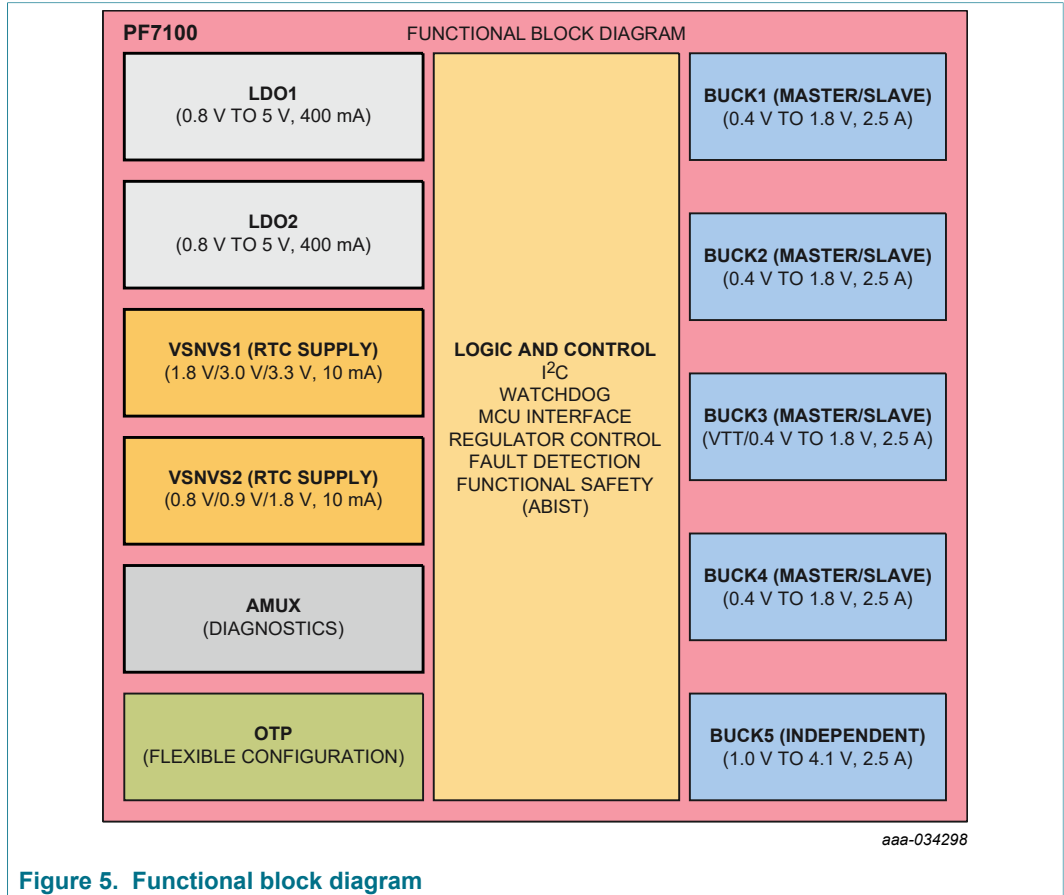

Figure 5. Functional block diagram

12.3 Power tree summary

The following table shows a summary of the voltage regulators in the PF7100.

Table 9. Voltage supply summary

Regulator	Type	Input supply	Regulated output range (V)	VOUT programmable step (mV)	IRATED (mA)
SW1	Buck	SW1IN ^[1]	0.4 V to 1.8 V	6.25	2500
SW2	Buck	SW2IN ^[1]	0.4 V to 1.8 V	6.25	2500
SW3	Buck	SW3IN ^[1]	VTT/0.4 V to 1.8 V	6.25	2500
SW4	Buck	SW4IN ^[1]	0.4 V to 1.8 V	6.25	2500
SW5	Buck	SW5IN ^[1]	1.0 V to 4.1 V	—	2500
LDO1	Linear (P-type)	LDO1IN	0.8 V to 5.0 V	—	400
LDO2	Linear (P-type)	LDO2IN	0.8 V to 5.0 V	—	400
VSNVS1	LDO	VIN	1.8 V/3.0 V/3.3 V	—	10
VSNVS2	LDO	VIN	0.8 V/0.9 V/1.8 V	—	10

[1] Input supply for switching regulators must be capable to sink current to avoid overvoltage condition during power down sequence of the device.

12.4 Device differences

Table 10. Device differences

Description	PF7100 ASIL B	PF7100 QM	Bits not available on PF7100 QM
During the self-test, the device checks: <ul style="list-style-type: none"> The high speed oscillator circuit is operating within a maximum of 15 % tolerance A CRC is performed on the mirror registers during the self-test routine to ensure the integrity of the registers before powering up ABIST test on all voltage monitors and toggling signals 	Available	Not available	AB_SWx_OV AB_SWx_UV AB_LDOx_OVAB_LDOx_UV STEST_NOK
Fail-safe state: to lock down the system in case of critical failures cycling the PMIC On/Off	Available	Not available	FS_CNT[3:0] OTP_FS_BYPASS OTP_FS_MAX_CNT[3:0] OTP_FS_OK_TIMER[2:0]
ABIST on demand	Available	Not available	AB_RUN
Active safe state: allow the FSOB to remain asserted as long as any of the non-safe conditions are present. Allow the system to be set in safe state via the FSOB pin.	Available	Not available	FSOB_ASS_NOK OTP_FSOB_ASS_EN (always 0)
Secure I ² C write: I ² C write procedure to modify registers dedicated to safety features (I ² C CRC is still available)	Available	Not available	I2C_SECURE_EN OTP_I2C_SECURE_EN (always 0) RANDOM_GEN[7:0] RANDOM_CHK[7:0]

13 State machine

The PF7100 features a state of the art state machine for seamless processor interface. The state machine handles the IC startup, provides fault monitoring and reporting, and protects the IC and the system during fault conditions.

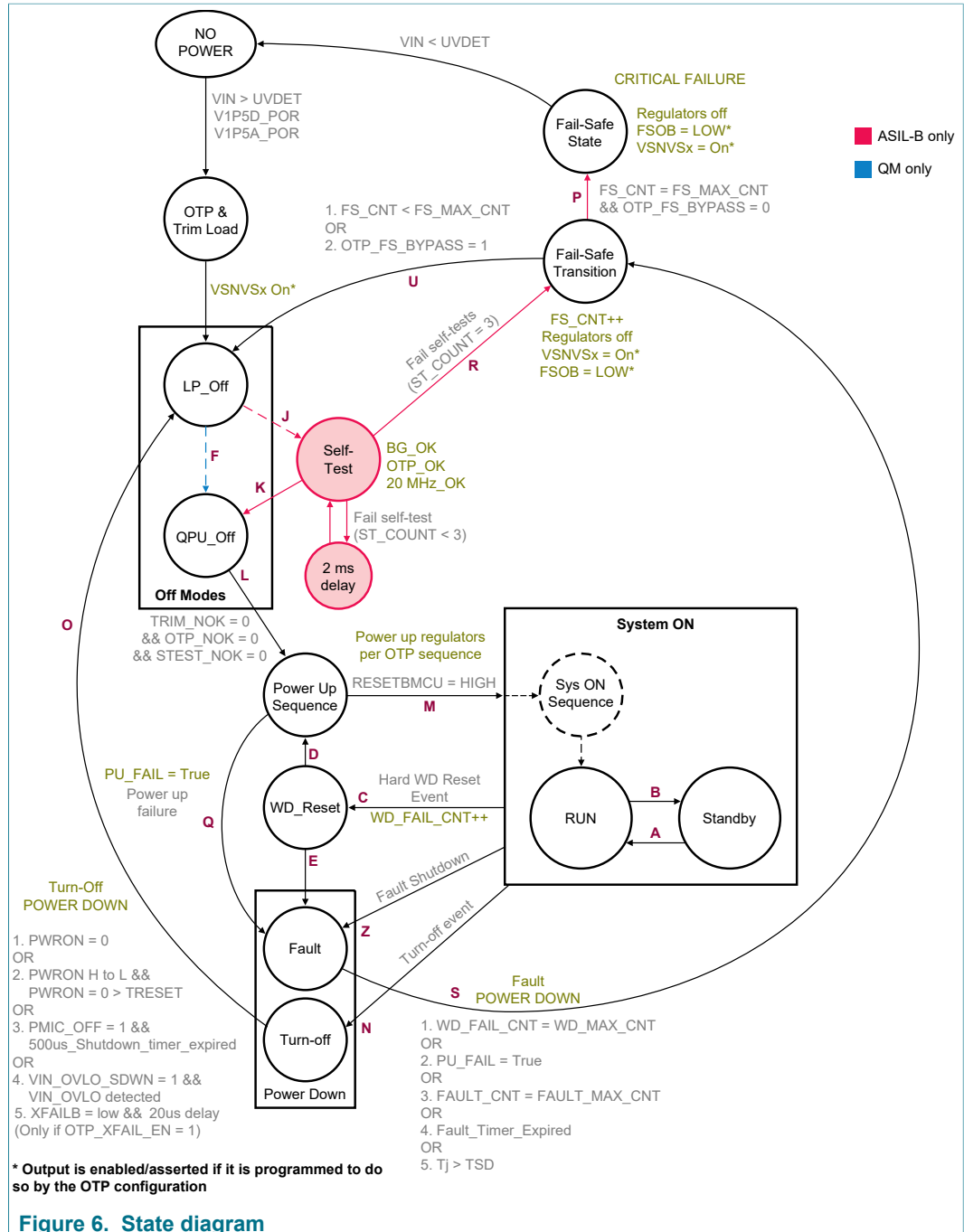

Figure 6. State diagram

Table 11 lists the conditions for the different state machine transitions.

Table 11. State machine transition definition

Symbol	Description	Conditions
Transition A	Standby to run	1. STANDBY = 0 && STANDBYINV bit = 0
		2. STANDBY = 1 && STANDBYINV bit = 1
Transition B	Run to standby	1. STANDBY = 1 && STANDBYINV bit = 0
		2. STANDBY = 0 && STANDBYINV bit = 1
Transition C	System on to WD reset	1. Hard WD Reset event
Transition D	WD reset to system on	1. 30 μ s delay passed && WD_EVENT_CNT < WD_MAX_CNT
Transition E	WD reset to power down (fault)	1. WD_EVENT_CNT = WD_MAX_CNT
Transition J	LP_Off to self-test (ASIL B only)	Transitory off state: device pass through LP_Off to Self-Test to QPU_Off (no power up event present) 1. LPM_OFF = 1 && TBBEN = Low
		Power up event from LP_Off state 2. LPM_OFF = 0 && TBBEN = Low && (PWRON = 1 && OTP_PWRON_MODE = 0) && UVDET < VIN < VIN_OVLO (or VIN_OVLO disabled) && T _j < TSD && TRIM_NOK = 0 && OTP_NOK = 0
		Power up event from LP_Off state 3. LPM_OFF = 0 && TBBEN = Low && (PWRON H to L && OTP_PWRON_MODE = 1) && UVDET < VIN < VIN_OVLO (or VIN_OVLO disabled) && T _j < T _{SD} && TRIM_NOK = 0 && OTP_NOK = 0
Transition K	Self-test to QPU_Off (ASIL B only)	Conditions: Transitory Off state to go into TBB Mode. Device pass through LP_Off to Self-Test to QPU_Off (no power up event present)
		4. TBBEN = high (V1P5D)
Transition K	Self-test to QPU_Off (ASIL B only)	1. Pass Self-Tests
		2. TBBEN = high (V1P5D)

7-channel power management integrated circuit for high performance applications

Symbol	Description	Conditions
Transition F	LP_Off to QPU_Off (QM only)	Transitory Off state: device pass through LP_Off to QPU_Off (no power up event present) 1. LPM_OFF = 1 && TBBEN = Low
		Power up event from LP_Off state 2. LPM_OFF = 0 && TBBEN = Low && (PWRON = 1 && OTP_PWRON_MODE = 0) && UVDET < VIN < VIN_OVLO (or VIN_OVLO disabled) && T _J < T _{SD} && TRIM_NOK = 0 && OTP_NOK = 0
		Power up event from LP_Off state 3. LPM_OFF = 0 && TBBEN = Low && (PWRON H to L && OTP_PWRON_MODE = 1) && UVDET < VIN < VIN_OVLO (or VIN_OVLO disabled) && T _J < T _{SD} && TRIM_NOK = 0 && OTP_NOK = 0
		Transitory Off state: device pass through LP_Off to QPU_Off (no power up event present) 4. TBBEN = High (V1P5D)
Transition L	QPU_Off to power up	Transitory QPU_Off state, power on event occurs from LP_Off state, after self-test is passed, QPU_Off is just a transitory state until power up sequence starts. 1. LPM_OFF = 0 && TBBEN = Low && TRIM_NOK = 0 && OTP_NOK = 0 && STEST_NOK = 0 && OTP_XFAILB_EN = 0
		Power up event from QPU_Off state 2. LPM_OFF = 1 && (PWRON = 1 && OTP_PWRON_MODE = 0) && T _J < T _{SD} && UVDET < VIN < VIN_OVLO (or VIN_OVLO disabled) && TRIM_NOK = 0 && OTP_NOK = 0 && STEST_NOK = 0 && OTP_XFAILB_EN = 0
		Power up event from QPU_Off state 3. LPM_OFF = 1 && (PWRON H to L && OTP_PWRON_MODE = 1) && T _J < T _{SD} && UVDET < VIN < VIN_OVLO (or VIN_OVLO disabled) && TRIM_NOK = 0 && OTP_NOK = 0 && STEST_NOK = 0 && OTP_XFAILB_EN = 0
		Power up event from QPU_Off state during TBB mode 4. TBBEN = 1 && (PWRON = 1 && OTP_PWRON_MODE = 0) && T _J < T _{SD} && UVDET < VIN < VIN_OVLO (or VIN_OVLO disabled) && TRIM_NOK = 0 && OTP_NOK = 0 && STEST_NOK = 0 && OTP_XFAILB_EN = 0

7-channel power management integrated circuit for high performance applications

Symbol	Description	Conditions
		Power up event from QPU_Off state during TBB mode 5. TBBEN = 1 && (PWRON H to L && OTP_PWRON_MODE = 1) && T _J < T _{SD} && UVDET < VIN < VIN_OVLO (or VIN_OVLO disabled) && TRIM_NOK = 0 && OTP_NOK = 0 && STEST_NOK = 0 && OTP_XFAILB_EN = 0
		Transitory QPU_Off state, Power on event occurs from LP_Off state, after Self-test is passed, QPU_Off is just a transitory state until power up sequence starts 6. LPM_OFF = 0 && TBBEN = Low && TRIM_NOK = 0 && OTP_NOK = 0 && STEST_NOK = 0 && OTP_XFAILB_EN = 1 && XFAILB = HIGH
		Power up event from QPU_Off state 7. LPM_OFF = 1 && (PWRON = 1 && OTP_PWRON_MODE = 0) && T _J < T _{SD} && UVDET < VIN < VIN_OVLO (or VIN_OVLO disabled) && TRIM_NOK = 0 && OTP_NOK = 0 && STEST_NOK = 0 && OTP_XFAILB_EN = 1 && XFAILB = HIGH
		Power up event from QPU_Off state 8. LPM_OFF = 1 && (PWRON H to L && OTP_PWRON_MODE = 1) && T _J < T _{SD} && UVDET < VIN < VIN_OVLO (or VIN_OVLO disabled) && TRIM_NOK = 0 && OTP_NOK = 0 && STEST_NOK = 0 && OTP_XFAILB_EN = 1 && XFAILB = HIGH
		Power up event from QPU_Off state during TBB mode 9. TBBEN = 1 && (PWRON = 1 && OTP_PWRON_MODE = 0) && T _J < T _{SD} && UVDET < VIN < VIN_OVLO (or VIN_OVLO disabled) && TRIM_NOK = 0 && OTP_NOK = 0 && STEST_NOK = 0 && OTP_XFAILB_EN = 1 && XFAILB = HIGH
		Power up event from QPU_Off state during TBB mode 10. TBBEN = 1 && (PWRON H to L && OTP_PWRON_MODE = 1) && T _J < T _{SD} && UVDET < VIN < VIN_OVLO (or VIN_OVLO disabled) && TRIM_NOK = 0 && OTP_NOK = 0 && STEST_NOK = 0 && OTP_XFAILB_EN = 1 && XFAILB = HIGH
Transition M	Power up sequence to system on	1. RESETBMCU is released as part of the power up sequence

Symbol	Description	Conditions
Transition N	System on to power down (turn off)	Requested turn off event 1. OTP_PWRON_MODE = 0 && PWRON = 0
		Requested turn off event 2. OTP_PWRON_MODE = 1 && (PWRON H to L && PWRON = low for t > TRESET)
		Requested turn off event 3. PMIC_OFF = 1 && 500µs_Shutdown_Timer_Expired
		Protective turn off event (no PMIC fault) 4. VIN_OVLO_SDWN=1 && VIN_OVLO detected for longer than VIN_OVLO_DBNC time
		External turn off event (no PMIC fault) 5. OTP_XFAILB_EN = 1 && XFAILB = Low && 20µs synchronization time is expired
Transition Z	System on to power down (fault)	Turn off event due to PMIC fault 1. Fault Timer expired
		Turn off event due to PMIC fault 2. FAULT_CNT = FAULT_MAX_CNT
		Turn off event due to PMIC fault 3. Thermal shutdown T _J > T _{SD}
Transition O	Power down (turn off) to LP_Off	Requested turn off event moves directly to LP_Off 1. Power down sequences finished
Transition Q	Power up to power down (fault)	Power up failure 1. Failure during power up sequence
Transition R	Self-test to fail-safe transition	1. Self-tests fail 3 times && TBBEN = low
Transition S	Power down (fault) to fail-safe transition	Turn off event due to a fault condition moves to fail-safe transition 1. Power down sequence is finished
Transition U	Fail-safe transition to LP_Off	1. FS_CNT < FS_MAX_CNT
		2. OTP_FS_BYPASS = 1
Transition P	Fail-safe transition to fail-safe state (ASIL B only)	1. FS_CNT = FS_MAX_CNT && OTP_FS_BYPASS = 0

13.1 States description

13.1.1 OTP/TRIM load

Upon VIN application, V1P5D and V1P5A regulators are turned on automatically. Once the V1P5D and V1P5A cross their respective POR thresholds, the fuses (for trim and OTP) are loaded into the mirror registers and into the functional I²C registers if configured by the voltage on the VDDOTP pin.

The fuse circuits have a CRC error check routine which reports and protects against register loading errors on the mirror registers. If a register loading error is detected, the corresponding TRIM_NOK or OTP_NOK flag is asserted. See [Section 17 "OTP/TBB and hardware default configurations"](#) for details on handling fuse load errors.

If no fuse load errors are present, VSNVSx is configured as indicated in the OTP configuration bits, and the state machine moves to the LP_OFF state.

13.1.2 LP_Off state

The LP_Off state is a low power off mode selectable by the LPM_OFF bit during the system-on modes. By default, the LPM_OFF = 0 when VIN crosses the UVDET threshold, therefore the state machine stops at the LP_Off state until a valid power up event is present. When LPM_OFF = 1, the state machine transitions automatically to the QPU_Off state if no power up event has been present and waits in the QPU_Off until a valid power up event is present.

The selection of the LPM_OFF bit is based on whether prioritizing low quiescent current (stay in LP_Off) or quick power up (move to QPU_Off state).

If a power up event is started in LP_Off state with LPM_OFF = 0 and a fuse loading error is detected, the PF7100 ignores the power up event and remains in the LP_Off state to avoid any potential damage to the system.

To be in LP_Off state, it is necessary to have VIN present.

13.1.3 Self-test routine (ASIL B only)

When device transitions from the LP_Off state, it turns on all necessary internal circuits as it moves into the self-test routine and performs a self-check routine to verify the integrity of the internal circuits.

During the self-test routine the following blocks are verified:

- The high-speed clock circuit is operating within a maximum of 15 % tolerance
- The output of both the voltage generation band gap and the monitoring band gap are not more than 4 % to 12 % apart from each other
- A CRC is performed on the mirror registers during the self-test routine, to ensure the integrity of the registers before powering up
- ABIST test on all voltage monitors.

To allow for varying settling times for the internal band gap and clocks, the self-test block is executed up to 3 times (with 2.0 ms between each test), if a failure is encountered, the state machine proceeds to the fail-safe transition.

A failure in the ABIST test is not interpreted as a self-test failure and it only sets the corresponding ABIST flag for system information. The MCU is responsible for reading the information and deciding whether it can continue with a safe operation. See [Section 18.1 "System safety strategy"](#) for more information about the functional safety strategy.

Upon a successful self-test, the state machine proceeds to the QPU_Off state.

13.1.4 QPU_Off state

The QPU_Off state is a higher power consumption off mode, in which all internal circuitry required for a power on is biased and ready to start a power up sequence.

If LPM_OFF = 1 and no turn on event is present, the device stops at the QPU_Off state, and waits until a valid turn on event is present.

In this state, if VDDIO supply is provided externally, the device is able to communicate through I²C to access and modify the mirror registers in order to operate the device in TBB mode or to program the OTP registers as described in [Section 17 "OTP/TBB and hardware default configurations"](#).

If a power up event is started and any of the TRIM_NOK, OTP_NOK or STEST_NOK flags are asserted, the device ignores the power up event and remains in the QPU_Off state. See [Section 17 "OTP/TBB and hardware default configurations"](#) for more details on debugging a fuse loading failure.

Upon a power up event, the default configuration from OTP or hardware is loaded into their corresponding I²C functional register in the transition from QPU_Off to power up state.

13.1.5 Power up sequence

During the power up sequence, the external regulators are turned on in a predefined order as programmed by the default (OTP or hardware) sequence.

If PGOOD is used as a GPO, it can also be set high as part of the power up sequence in order to allow sequencing of any external supply/device controlled by the PGOOD pin.

The RESETBMCU is also programmed as part of the power up sequence, and it is used as the condition to enter the system-on states. The RESETBMCU may be released in the middle of the power up sequence, in this case, the remaining supplies in the power up continue to power up as the device is in the run state. See [Section 14.5.2 "Power up sequencing"](#) for details.

13.1.6 System-on states

During the system-on state, the MCU is powered and out of reset and the system is fully operational.

The system-on is a virtual state composed by two modes of operations:

- Run state
- Standby state

Register to control the regulators output voltage, regulator enable, interrupt masks, and other miscellaneous functions can be written to or read from the functional I²C register map during the system-on states.

13.1.6.1 Run state

If the power up state is successfully completed, the state machine transitions to the run state. In this state, RESETBMCU is released high, and the MCU is expected to boot up and set up specific registers on the PMIC as required during the system boot up process.

The run mode is intended to be used as the normal mode of operation for the system.

Each regulator has specific registers to control its output voltage, operation mode and/or enable/disable state during the run state.

By default, the VSWx_RUN[7:0] / VLDOx_RUN[3:0] registers are loaded with the data stored in the OTP_VSWx[7:0] or OTP_VLDOx[3:0] bits respectively.

SW5 uses only one global register to configure the output voltage during run or standby mode. Upon power up, the VSW5[4:0] bits are loaded with the values of the OTP_VSW5[4:0].

Upon power up, if the switching regulator is part of the power up sequence, the SWx_RUN_MODE[1:0] bits are loaded as needed by the system:

7-channel power management integrated circuit for high performance applications

- When `OTP_SYNCIN_EN = 1`, default `SWx_RUN_MODE` at power up is always set to PWM (0b01)
- When `OTP_SYNCOUT_EN = 1`, default `SWx_RUN_MODE` at power up is always set to PWM (0b01)
- When `OTP_FSS_EN = 1`, default `SWx_RUN_MODE` at power up shall always set to PWM (0b01)
- If none of the above conditions are met, the default value of the `SWx_RUN_MODE` bits at power up are set by the `OTP_SW_MODE` bits.

When `OTP_SW_MODE = 0`, the default values of the `SWx_RUN_MODE` bits are set to 0b11 (Autoskip).

When `OTP_SW_MODE = 1`, the default values of the `SWx_RUN_MODE` bits are set to 0b01 (PWM).

If the switching regulator is not part of the power up sequence, the `SWx_RUN_MODE[1:0]` bits are loaded with 0b00 (OFF mode).

Likewise, if the LDO is part of the power up sequence, the `LDOx_RUN_EN` bit is set to 1 (enabled) by default. If the LDO is not selected as part of the power up sequence, the `LDOx_RUN_EN` bit is set to 0 (disabled) by default.

In a typical system, each time the processor boots up (PMIC transitions from off mode to run state), all output voltage configurations are reset to the default OTP configuration, and the MCU should configure the PMIC to its desired usage in the application.

13.1.6.2 Standby state

The standby state is intended to be used as a low-power (state retention) mode of operation. In this state, the voltage regulators can be preset to a specific low power configuration in order to reduce the power consumption during system's sleep or state retention modes of operations.

The standby state is entered when the `STANDBY` pin is pulled high or low as defined by the `STANDBYINV` bit. The `STANDBY` pin is pulled high/low by the MCU to enter/exit system low power mode. See [Section 14.9.2 "STANDBY"](#) for detailed configuration of the `STANDBY` pin.

Each regulator has specific registers to control its output voltage, operation mode and/or enable/disable state during the standby state.

By default, the `VSWx_STBY[7:0]` / `VLDOx_STBY[3:0]` registers are loaded with the data stored in the `OTP_VSWx[7:0]` or `OTP_VLDOx[3:0]` bits respectively.

Upon power up, if the switching regulator is part of the power up sequence, the `SWx_STBY_MODE[1:0]` bits are loaded as needed by the system:

- When `OTP_SYNCIN_EN = 1`, default `SWx_STBY_MODE` at power up is always set to PWM (0b01)
- When `OTP_SYNCOUT_EN = 1`, default `SWx_STBY_MODE` at power up is always set to PWM (0b01)
- When `OTP_FSS_EN = 1`, default `SWx_STBY_MODE` at power up shall always set to PWM (0b01)
- If none of the above conditions are met, the default value of the `SWx_STBY_MODE` bits at power up will be set by the `OTP_SW_MODE` bits.

When `OTP_SW_MODE = 0`, the default values of the `SWx_STBY_MODE` bits are set to 0b11 (Autoskip).

7-channel power management integrated circuit for high performance applications

When `OTP_SW_MODE = 1`, the default values of the `SWx_STBY_MODE` bits are set to `0b01` (PWM).

If the switching regulator is not part of the power up sequence, the `SWx_STBY_MODE[1:0]` bits are loaded with `0b00` (OFF mode).

Likewise, if the LDO is part of the power up sequence, the `LDOx_RUN_EN` bit is set to 1 (enabled) by default. If the LDO is not selected as part of the power up sequence, the `LDOx_RUN_EN` bit is set to 0 (disabled) by default.

Upon power up, the standby registers are loaded with the same default OTP values as the run mode. The MCU is expected to program the desired standby values during boot up.

If any of the external regulators are disabled in the standby state, the power down sequencer is engaged as described in [Section 14.6.2 "Power down sequencing"](#).

13.1.7 WD_Reset

When a hard watchdog reset is present, the state machine increments the `WD_EVENT_CNT[3:0]` register and compares against the `WD_MAX_CNT[3:0]` register. If `WD_EVENT_CNT[3:0] = WD_MAX_CNT[3:0]`, the state machine detects a cyclic watchdog failure, it powers down the external regulators and proceeds to the fail-safe transition.

If `WD_EVENT_CNT[3:0] < WD_MAX_CNT[3:0]`, the state machine performs a hard WD reset.

A hard WD reset can be generated from either a transition in the WDI pin or a WD event initiated by the internal watchdog counter as described in [Section 15.10.2 "Watchdog reset behaviors"](#).

13.1.8 Power down state

During power down state, all regulators except `VSNVSx` are disabled as configured in the power down sequence. The power down sequence is programmable as defined in [Section 14.6.2 "Power down sequencing"](#).

Two types of events may lead to the power down sequence:

- Non-faulty turn off events: move directly into `LP_Off` state as soon as power down sequence is finalized
- Turn off events due to a PMIC fault: move to the fail-safe transition as soon as the power down sequence is finalized

13.1.9 Fail-safe transition

The fail-safe transition is entered if the PF7100 initiates a turn off event due to a PMIC fault.

If the fail-safe transition is entered, the PF7100 provides four FAIL bits to indicate the source of the failure:

- The `PU_FAIL` is set to 1 when the device shuts down due to a power up failure
- The `WD_FAIL` is set to 1 when the device shuts down due to a watchdog event counter max out
- The `REG_FAIL` is set to 1 when the device shuts down due to a regulator failure (fault counter maxed out or fault timer expired)

- The TSD_FAIL is set to 1 when the device shuts down due to a thermal shutdown

The value of the FAIL bits is retained as long as VIN > UVDET.

The MCU can read the FAIL bits during the system-on states in order to obtain information about the previous failure and can clear them by writing a 1 to them, provided the state machine is able to power up successfully after such failure.

In the PF7100 ASIL B part numbers, when the state machine enters the fail-safe transition, a fail-safe counter is compared and increased, if the FS_CNT[3:0] reaches the maximum count, the device can be programmed to move directly to the fail-safe state to prevent a cyclic failure from happening.

13.1.10 Fail-safe state (ASIL B only)

The fail-safe state works as a safety lock-down upon a critical device/system failure. It is reached when the FS_CNT [3:0] = FS_MAX_CNT [3:0].

A bit is provided to enable or disable the device to enter the fail-safe state upon a cyclic failure. When the OTP_FS_BYPASS = 1, the fail-safe bypass operation is enabled and the device always move to the LP_Off state, regardless of the value of the FS_CNT[3:0]. If the OTP_FS_BYPASS = 0, the fail-safe bypass is disabled, and the device moves to the fail-safe state when the proper condition is met.

The maximum number of times the device can pass through the fail-safe transition continuously prior to moving to a fail state is programmed by the OTP_FS_MAX_CNT[3:0] bits. If the FS_MAX_CNT[3:0] = 0x00, the device moves into the fail-safe state as soon as it fails for the very first time.

If the FSOB pin is programmed to assert upon a specific fault, the FSOB pin remains asserted low during the fail-safe state if the corresponding fault is present when the PF7100 reaches the fail-safe state.

The device can exit the fail-safe state only after a power cycle (VIN crossing UVDET) event is present.

To avoid reaching the fail-safe state due to isolated fail-safe transition events, the FS_CNT [3:0] is gradually decreased based on a fail-safe OK timer. The OTP_FS_OK_TIME[2:0] bits select the default time configuration for the fail-safe OK timer between 1 to 60 min.

Table 12. Fail-safe OK timer configuration

OTP_FS_OK_TIME[2:0]	FS_CNT decrease period (min)
000	1
001	5
010	10
011	15
100	20
101	30
110	45
111	60

When the fail-safe OK timer reaches the configured time during the system-on states, the state machine decreases the FS_CNT[3:0] bits by one and starts a new count until the

FS_CNT[3:0] is 0x00. The FS_CNT[3:0] may be manually cleared during the system-on state if the system wants to control this counter manually.

14 General device operation

14.1 UVDET

UVDET works as the main operation threshold for the PF7100. Crossing UVDET on the rising edge is a mandatory condition for OTP fuses to be loaded into the mirror registers and allows the main PF7100 operation.

If VIN is below the UVDET threshold, the device remains in an unpowered state. A 200 mV hysteresis is implemented on the UVDET comparator to set the falling threshold.

Table 13. UVDET threshold

Symbol	Parameter	Min	Typ	Max	Unit
UVDET	Rising UVDET	2.7	2.8	2.9	V
UVDET	Falling UVDET	2.5	2.6	2.7	V

14.2 VIN OVLO condition

The VIN_OVLO circuit monitors the main input supply of the PF7100. When this block is enabled, the PF7100 monitors its input voltage and can be programmed to react to an overvoltage in two ways:

- When the VIN_OVLO_SDWN = 0, the VIN_OVLO event triggers an OVLO interrupt but does not turn off the device
- When the VIN_OVLO_SDWN = 1, the VIN_OVLO event initiates a power down sequence

When the VIN_OVLO_EN = 0, the OVLO monitor is disabled and when the VIN_OVLO_EN = 1, the OVLO monitor is enabled. The default configuration of the VIN_OVLO_EN bit is set by the OTP_VIN_OVLO_EN bit in OTP. Likewise, the default value of the VIN_OVLO_SDWN bit is set by the OTP_VIN_OVLO_SDWN upon power up.

During a power up transition, if the OTP_VIN_OVLO_SDWN = 0, the device allows the external regulators to come up and the PF7100 announces the VIN_OVLO condition through an interrupt after RESETBMCU is de-asserted. If the OTP_VIN_OVLO_SDWN = 1, the device stops the power up sequence and returns to the corresponding OFF mode.

Debounce on the VIN_OVLO comparator is programmable to 10 μ s, 100 μ s or 1.0 ms, by the VIN_OVLO_DBNC[1:0] bits. The default value for the VIN_OVLO debounce is set by the OTP_VIN_OVLO_DBNC[1:0] bits upon power up.

Table 14. VIN_OVLO debounce configuration

VIN_OVLO_DBNC[1:0]	VIN OVLO debounce value (μ s)
00	10
01	100
10	1000
11	Reserved

Table 15. VIN_OVLO specifications

Symbol	Parameter	Min	Typ	Max	Unit
VIN_OVLO	VIN overvoltage lockout rising ^[1]	5.6	5.8	6.0	V
VIN_OVLO_HYS	VIN overvoltage lockout hysteresis ^[1]	—	—	100	mV

[1] Operating the device above the maximum VIN = 5.5 V for extended period of time may degrade and cause permanent damage to the device.

14.3 IC startup timing with PWRON pulled up

The PF7100 features a fast internal core power up sequence to fulfill system power up timings of 5.0 ms or less, from power application until MCU is out of reset. Such requirement needs a maximum ramp up time of 1.5 ms for VIN to cross the UVDET threshold in the rising edge.

A maximum core biasing time of 1.5 ms from VIN crossing to UVDET until the beginning of the power up sequence is ensured to allow up to 1.5 ms time frame for the voltage regulators power up sequence.

Timing for the external regulators to start up is programmed by default in the OTP fuses.

The 5.0 ms power up timing requirement is only applicable when the PWRON pin operates in level sensitive mode OTP_PWRON_MODE = 0, however turn on timing is expected to be the same for both level, or edge sensitive modes after the power on event is present.

In applications using the VSNVSx regulator, if VSNVSx is required to reach regulation before system regulators come up, the system should use the SEQ[7:0] bits to delay the system regulators to allow enough time for VSNVSx to reach regulation before the power up sequence is started.

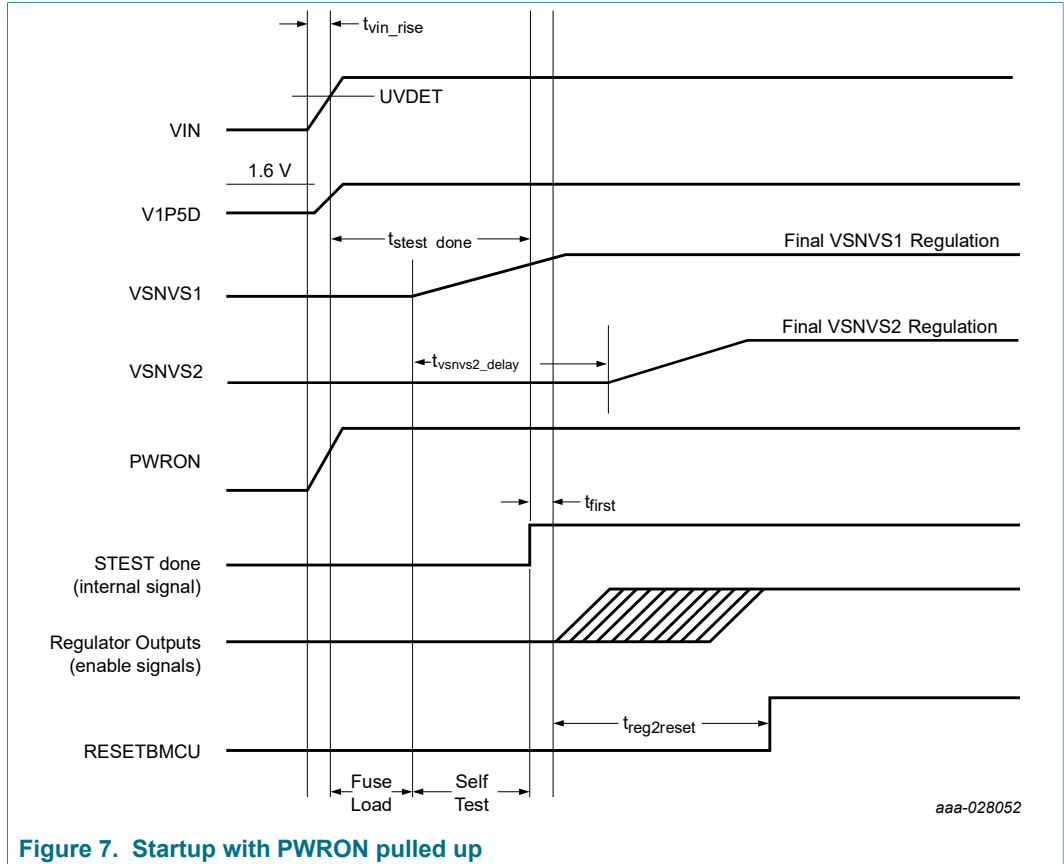

Figure 7. Startup with PWRON pulled up

Table 16. Startup timing requirements (PWRON pulled up)

Symbol	Description	Min	Typ	Max	Unit
t_{vin_rise}	Rise time of VIN from VPWR application to UVDET (system dependent)	10	—	1500	μs
t_{stest_done}	Time from VIN crossing UVDET to STEST_ done going high (self-test performed and passed)	—	—	1.4	ms
t_{vsnvs2_delay}	Time delay from fuse load to VSNVS2 start up	—	2	—	ms
t_{first}	Time from STEST_ done to first slot of power up sequence	—	—	100	μs
$t_{reg2reset}$	Time from first regulator enabled to RESETBMCU asserted to guarantee 5.0 ms PMIC boot up	[1] —	—	1.5	ms

[1] External regulators power up sequence time ($t_{reg2reset}$) is programmed by OTP and may be longer than 1.5 ms. However, 1.5 ms is the maximum allowed time to ensure power up within 5.0 ms.

14.4 IC startup timing with PWRON pulled low during VIN application

It is possible that PWRON is held low when VIN is applied. By default, LPM_OFF bit is reset to 0 upon crossing UVDET, therefore the PF7100 remains in the LP_Off state as described in [Section 13.1.2 "LP_Off state"](#). In this scenario, quiescent current in the LP_Off state is kept to a minimum. When PWRON goes high with LPM_OFF = 0, the PMIC startup is expected to take longer, since it has to enable most of the internal circuits and perform the self-test before starting a power up sequence.

The following figure shows startup timing with LPM_OFF = 0.

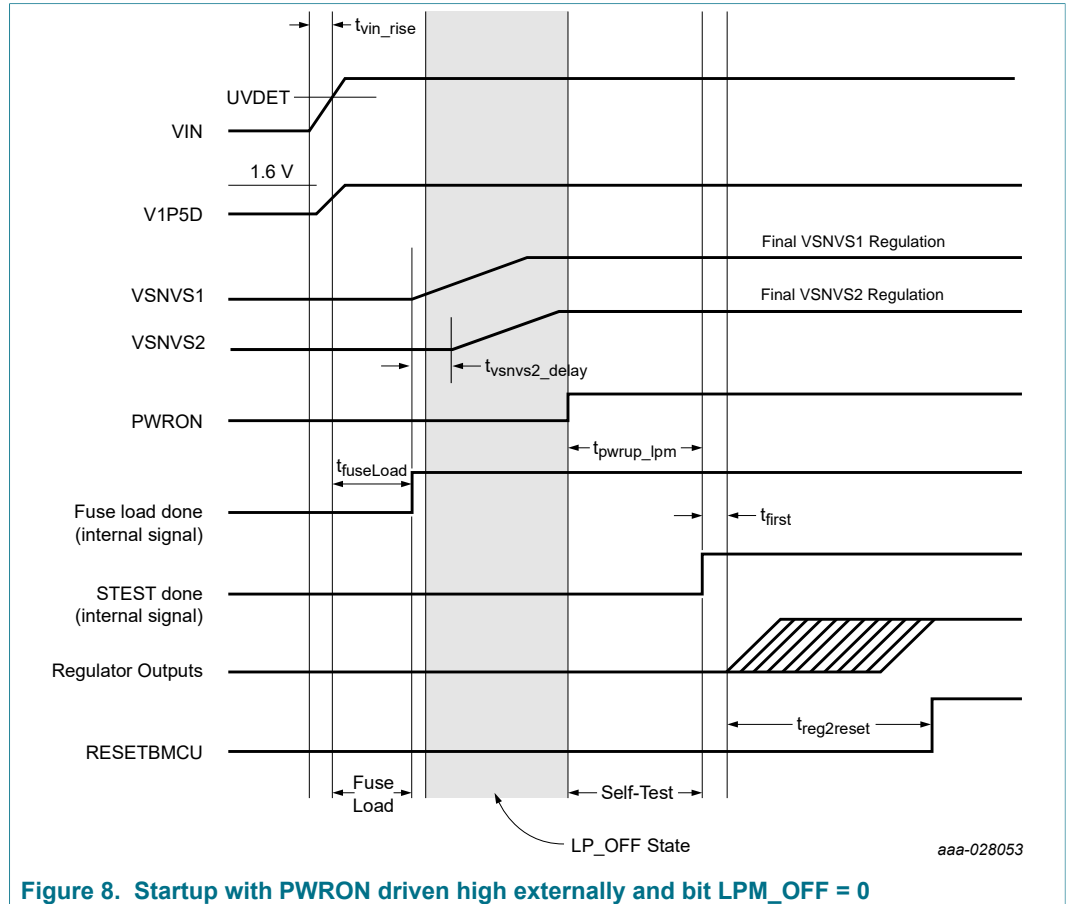

Figure 8. Startup with PWRON driven high externally and bit LPM_OFF = 0

Table 17. Startup with PWRON driven high externally and LPM_OFF = 0

Symbol	Parameter	Min	Typ	Max	Unit
t_{vin_rise}	Rise time of VIN from VPWR application to UVDET (system dependent)	10	—	1500	μs
$t_{fuseload}$	Time from VIN crossing UVDET to Fuse_Load_done (fuse loaded correctly)	—	—	600	μs
t_{pwrup_lpm}	Time from PWRON going high to the STEST_done (self-test performed and passed)	—	—	700	μs
t_{vsnvs2_delay}	Time delay from fuse load to VSNVS2 start up	—	2	—	ms
t_{first}	Time from STEST_done to first slot of power up sequence	—	—	100	μs
$t_{reg2reset}$	Time from first regulator enabled to RESETBMCU asserted to guarantee 5.0 ms PMIC boot up	[1] —	—	1.5	ms

[1] External regulators power up sequence time ($t_{reg2reset}$) is programmed by OTP and may be longer than 1.5 ms.

14.5 Power up

14.5.1 Power up events

Upon a power cycle ($V_{IN} > UVDET$), the LPM_OFF bit is reset to 0, therefore the device moves to the LP_Off state by default. The actual value of the LPM_OFF bit can be changed during the run mode and is maintained until V_{IN} crosses the UVDET threshold.

In either one of the Off modes, the PF7100 can be enabled by the following power up events:

1. When $OTP_PWRON_MODE = 0$, PWRON pin is pulled high.
2. When $OTP_PWRON_MODE = 1$, PWRON pin experiences a high to low transition and remains low for as long as the PWRON_DBNC timer.

A power up event is valid only if:

- $V_{IN} > UVDET$
- $V_{IN} < V_{IN_OVLO}$ (unless the OVLO is disabled or $OTP_VIN_OVLO_SDWN = 0$)
- $T_j <$ thermal shutdown threshold
- $TRIM_NOK = 0 \ \&\& \ OTP_NOK = 0 \ \&\& \ STEST_NOK = 0$

14.5.2 Power up sequencing

The power up sequencer controls the time and order in which the voltage regulators and other controlling I/O are enabled when going from the OFF mode into the run state.

The $OTP_SEQ_TBASE[1:0]$ bits set the default timebase for the power up and power down sequencer.

The $SEQ_TBASE[1:0]$ bits can be modified during the system-on states in order to change the sequencer timing during run/standby transitions as well as the power down sequence.

Table 18. Power up timebase register

OTP bits $OTP_SEQ_TBASE[1:0]$	Functional bits $SEQ_TBASE[1:0]$	Sequencer timebase (μs)
00	00	30
01	01	120
10	10	250
11	11	500

The power up sequence may include any of the following:

- Switching regulators
- LDO regulators
- PGOOD pin if programmed as a GPO
- RESETBMCU

The default sequence slot for each one of these signals is programmed via the OTP configuration registers. And they can be modified in the functional I²C register map to change the order in which the sequencer behaves during the run/standby transitions as well as the power down sequence.

7-channel power management integrated circuit for high performance applications

The `_SEQ[7:0]` bits set the regulator/pin sequence from 0 to 254. Sequence code 0x00 indicates that the particular output is not part of the startup sequence and remains in off (in case of a regulator) or remains low/disabled (in case of PGOOD pin used as a GPO).

Table 19. Power up sequence registers

OTP bits OTP_SWx_SEQ[7:0]/ OTP_LDOx_SEQ[7:0]/ OTP_PGOOD_SEQ[7:0]/ OTP_RESETBMCU_SEQ[7:0]	Functional bits SWx_SEQ[7:0]/ LDOx_SEQ[7:0]/ PGOOD_SEQ[7:0]/ RESETBMCU_SEQ[7:0]	Sequence slot	Startup time (µs)
00000000	00000000	Off	Off
00000001	00000001	0	SLOT0 (right after PWRON event is valid)
00000010	00000010	1	SEQ_TBASE x SLOT1
.	.	.	.
.	.	.	.
.	.	.	.
11111111	11111111	254	SEQ_TBASE x SLOT254

If RESETBMCU is not programmed in the OTP sequence, it will be enabled by default after the last regulator programmed in the power up sequence.

When the `_SEQ[7:0]` bits of all regulators and PGOOD used as a GPIO are set to 0x00 (off) and a power on event is present, the device moves to the run state in slave mode. In this mode, the device is enabled without any voltage regulator or GPO enabled. If the RESETBMCU is not programmed in a power up sequence slot, it is released when the device enters the run state.

The slave mode is a special case of the power up sequence to address the scenario where the PF7100 is working as a slave PMIC, and supplies are meant to be enabled by the MCU during the system operation. In this scenario, if RESETBMCU is used, it is connected to the master RESETBMCU pin.

The PWRUP_I interrupt bit is asserted at the end of the power up sequence when the time slot of the last regulator in the sequence has ended.

[Figure 9](#) provides an example of the power up/down sequence coming from the OFF modes.

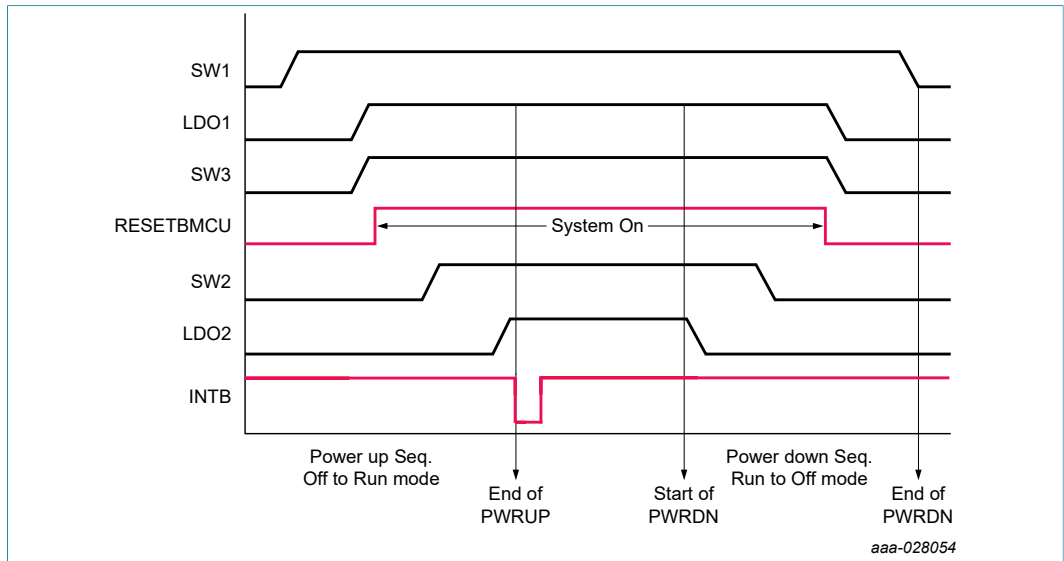

Figure 9. Power up/down sequence between OFF and system-on states

When transitioning from standby mode to run mode, the power up sequencer is activated only if any of the external regulators is re-enabled during this transition. If none of the regulators toggle from Off to On and only voltage changes are being performed when entering or exiting standby mode, the changes for the voltage regulators are made simultaneously rather than going through the power up sequencer.

Figure 10 shows an example of the power up/down sequence when transitioning between run and standby modes.

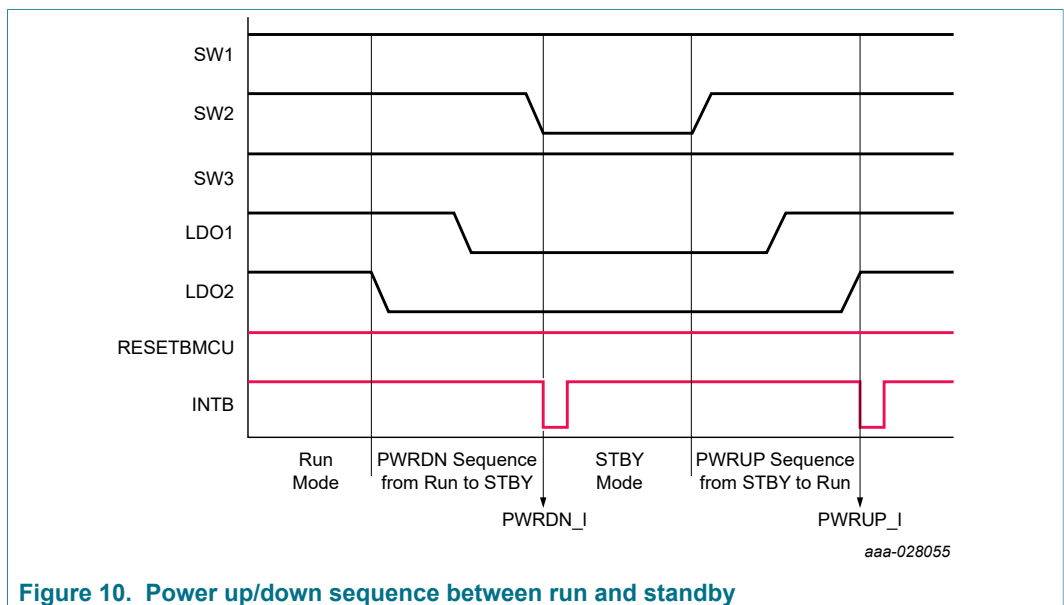

Figure 10. Power up/down sequence between run and standby

The PWRUP_I interrupt is set while transitioning from standby to run, even if the sequencer is not used. This is used to indicate that the transition is complete and device is ready to perform proper operation.

14.6 Power down

14.6.1 Turn off events

Turn off events may be requested by the MCU (non-PMIC fault related) or due to a critical failure of the PMIC (hard fault condition).

The following are considered non-PMIC failure turn off events:

1. When `OTP_PWRON_MODE = 0`, the device starts a power down sequence when the `PWRON` pin is pulled low.
2. When `OTP_PWRON_MODE = 1`, the device starts a power down sequence when the `PWRON` pin sees a transition from high to low and remains low for longer than `TRESET`.
3. When bit `PMIC_OFF` is set to 1, the device starts a 500 μ s shutdown timer. When the shutdown timer is started, the PF7100 sets the `SDWN_I` interrupt and asserts the `INTB` pin provided it is not masked. At this point, the MCU can read the interrupt and decide whether to continue with the turn off event or stop it in case it was sent by mistake.
If the `SDWN_I` bit is cleared before the 500 μ s shutdown timer is expired, the shutdown request is canceled and the shutdown timer is reset; otherwise, if the shutdown timer expires, the PF7100 starts a power down sequence.
The `PMIC_OFF` bit self-clears after `SDWN_I` flag is cleared.
4. When `VIN_OVLO_EN = 1` and `VIN_OVLO_SDWN = 1`, and a `VIN_OVLO` event is present.

Turn off events due to a hard fault condition:

1. If an `OV`, `UV` or `ILIM` condition is present long enough for the fault timer to expire.
2. In the event that an `OV`, `UV` or `ILIM` condition appears and clears cyclically, and the `FAULT_CNT[3:0] = FAULT_MAX_CNT[3:0]`.
3. If the watchdog fail counter is overflowed, that is `WD_EVENT_CNT = WD_MAX_CNT`.
4. When `Tj` crosses the thermal shutdown threshold as the temperature rises.

When the PF7100 experiences a turn off event due to a hard fault condition, the device passes through the fail-safe transition after regulators have been powered down.

14.6.2 Power down sequencing

During a power down sequence, output voltage regulators can be turned off in two different modes as defined by the `PWRDWN_MODE` bit.

1. When `PWRDWN_MODE = 0`, the regulators power down in sequential mode.
2. When `PWRDWN_MODE = 1`, the regulators power down by groups.

During transition from run to standby, the power down sequencer is activated in the corresponding mode. If any of the external regulators are turned off in the standby configuration. If external regulators are not turned off during this transition, the power down sequencer is bypassed and the transition happens at once (any associated DVS transitions could still take time).

The `PWRDN_I` interrupt is set at the end of the transition from run to standby when the last regulator has reached its final state, even if external regulators are not turned off during this transition.

14.6.2.1 Sequential power down

When the device is set to the sequential power down, it uses the same _SEQ[7:0] registers as the power up sequence to power down in reverse order.

All regulators with the _SEQ[7:0] bits set to 0x00, power down immediately and the remaining regulators power down one OTP_SEQ_TBASE[1:0] delay after, in reverse order as defined in the _SEQ[7:0] bits.

If PGOOD pin is used as a GPO, it is de-asserted as part of the power down sequence as indicated by the PGOOD_SEQ[7:0] bits.

If the MCU requires a different power down sequence, it can change the values of the SEQ_TBASE[1:0] and the _SEQ[7:0] bits during the system-on states.

When the state machine passes through any of the OFF modes, the contents of the SEQ_TBASE[1:0] and _SEQ[7:0] bits are reloaded with the corresponding mirror register (OTP) values before it starts the next power up sequence.

14.6.2.2 Group power down

When the device is configured to power down in groups, the regulators are assigned to a specific power down group. All regulators assigned to the same group are disabled at the same time when the corresponding group is due to be disabled.

Power down groups shut down in decreasing order starting from the lowest hierarchy group with a regulator shutting down (for instance, Group 4 being the lowest hierarchy and Group 1 the highest hierarchy group). If no regulators are set to the lowest hierarchy group, the power down sequence timer starts off the next available group that contains a regulator to power down.

Each regulator has its own _PDGRP[1:0] bits to set the power down group it belongs to as shown in [Table 20](#).

Table 20. Power down regulator group bits

OTP_SWx_PDGRP[1:0] OTP_LDOx_PDGRP[1:0] OTP_PGOOD_PDGRP[1:0] OTP_RESETMCU_PDGRP[1:0]	SWx_PDGRP[1:0] LDOx_PDGRP[1:0] PGOOD_PDGRP[1:0] RESETMCU_PDGRP[1:0]	Description
00	00	Regulator belongs to Group 4
01	01	Regulator belongs to Group 3
10	10	Regulator belongs to Group 2
11	11	Regulator belongs to Group 1

If PGOOD pin is used as a GPO, the PGOOD_PDGRP[1:0] is used to turn off the PGOOD pin in a specific group during the power down sequence. If PGOOD pin is used in power good mode, it is recommended that the OTP_PGOOD_PDGRP bits are set to 11 to ensure that the group power down sequencer does not detect these bits as part of Group 4.

Each one of power down groups have programmable time delay registers to set the time delay after the regulators in this group have been turned off, and the next group can start to power down.

Table 21. Power down counter delay

OTP bits OTP_GRPx_DLY[1:0]	Functional bits GRPx_DLY[1:0]	Power down delay (μ s)
00	00	120
01	01	250
10	10	500
11	11	1000

If RESETBMCU is required to be asserted first before any of the external regulators from the corresponding group, the RESETBMCU_DLY provides a selectable delay to disable the regulators after RESETBMCU is asserted.

Table 22. Programmable delay after RESETBMCU is asserted

OTP bits OTP_RESETBMCU_DLY[1:0]	Functional bits RESETBMCU_DLY[1:0]	RESETBMCU delay (μ s)
00	00	No delay
01	01	10
10	10	100
11	11	500

If RESETBMCU_DLY is set to 0x00, all regulators in the same power down group as RESETBMCU is disabled at the same time RESETBMCU is asserted.

[Figure 11](#) shows an example of the power down sequence when PWRDWN_MODE = 1.

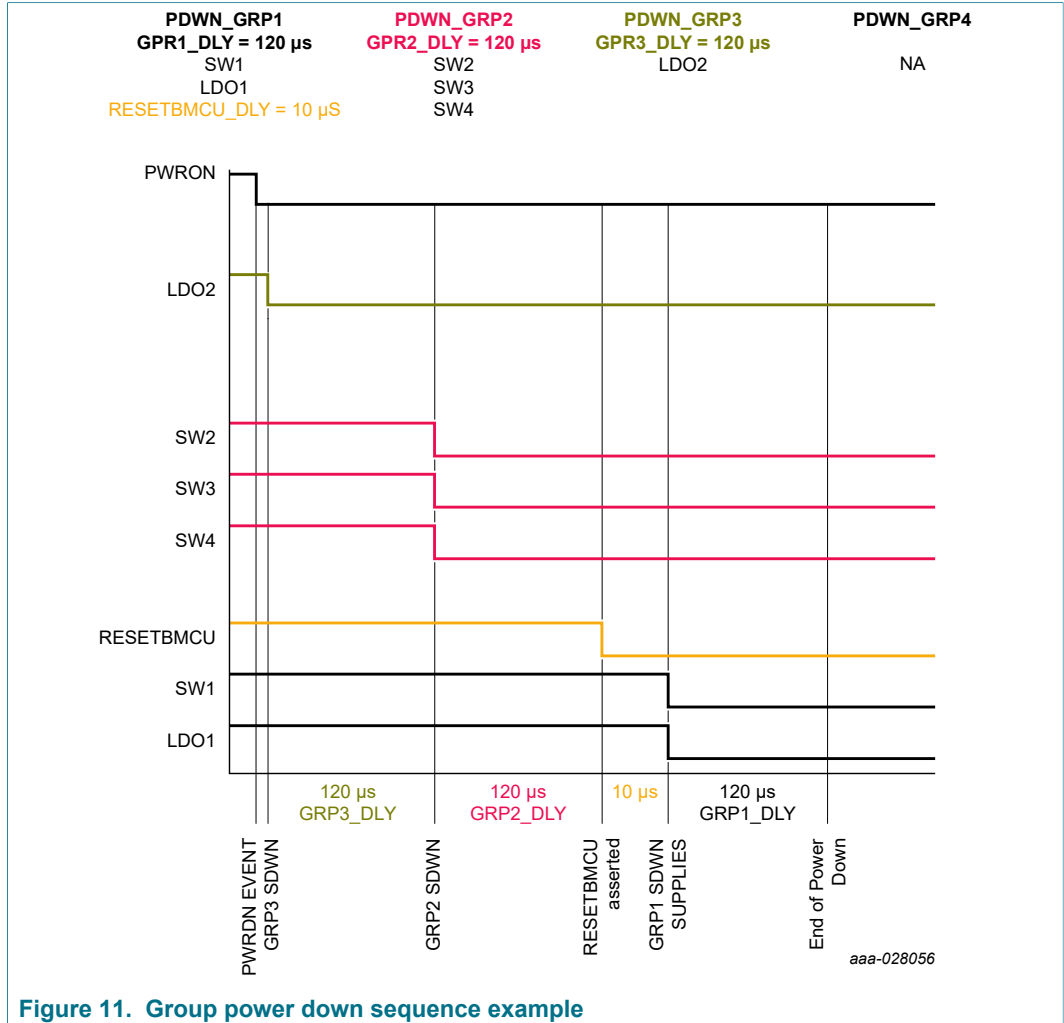

Figure 11. Group power down sequence example

14.6.2.3 Power down delay

After a power down sequence is started, the PWRON pin is masked until the sequence is finished and the programmable power down delay is reached, the device can then power up again if a power up event is present. The power down delay time can be programmed on OTP via the OTP_PD_SEQ_DLY[1:0] bits.

Table 23. Power down delay selection

OTP_PD_SEQ_DLY[1:0]	Delay after power down sequence
00	No delay
01	1.5 ms
10	5.0 ms
11	10 ms

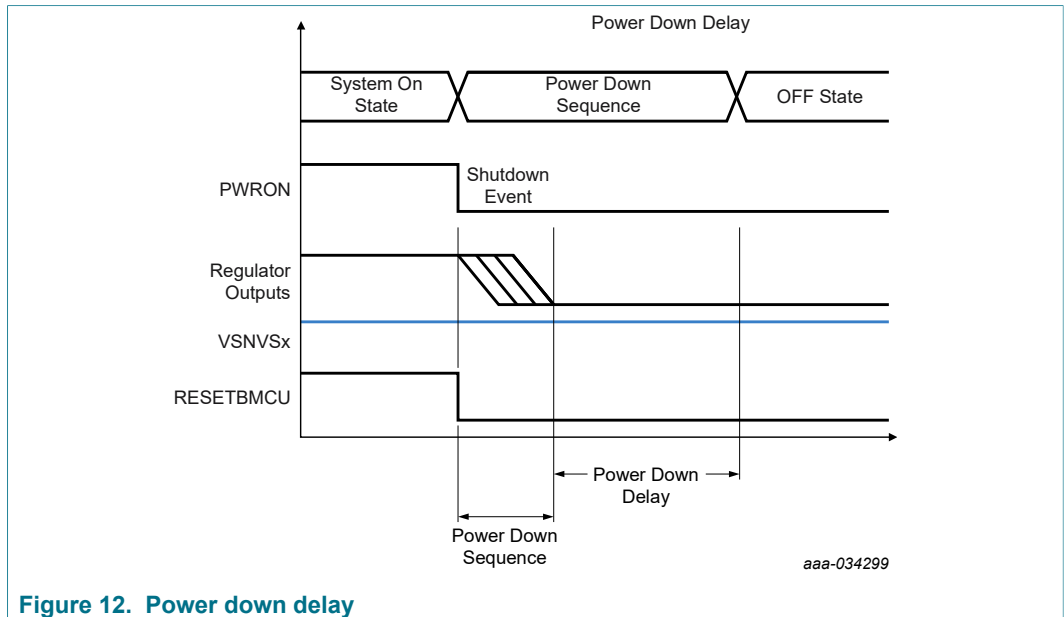

Figure 12. Power down delay

During a Hard WD reset, the power down shall also wait until the power down delay is reached before it can start the new power up sequence.

The default value of the OTP_PD_SEQ_DLY[1:0] bits on an unprogrammed OTP device is 00.

14.7 Fault detection

Three types of faults are monitored per regulator: UV, OV, and ILIM. Faults are monitored during power up sequence, run, standby, and WD reset states. A fault event is notified to the MCU through the INTB pin if the corresponding fault is not masked.

The fault configuration registers are reset to their default value after the power up sequence, and system must configure them as required during the boot-up process via I²C commands.

For each type of fault, there is an I²C bit that is used to select whether the regulator is kept enabled or disabled when the corresponding regulator experiences a fault event.

SWx_ILIM_STATE / LDOx_ILIM_STATE

- 0 = regulator disable upon an ILIM fault event
- 1 = regulator remains on upon an ILIM fault event

SWx_OV_STATE / LDOx_OV_STATE

- 0 = regulator disable upon an OV fault event
- 1 = regulator remains On upon an OV fault event

SWx_UV_STATE / LDOx_UV_STATE

- 0 = regulator disable upon an UV fault event
- 1 = regulator remains on upon an UV fault event

The following table lists the functional bits associated with enabling/disabling the external regulators when they experience a fault.

Table 24. Regulator control during fault event bits

Regulator	Bit to disable the regulator during current limit	Bit to disable the regulator during undervoltage	Bit to disable the regulator during overvoltage
SW1	SW1_ILIM_STATE	SW1_UV_STATE	SW1_OV_STATE
SW2	SW2_ILIM_STATE	SW2_UV_STATE	SW2_OV_STATE
SW3	SW3_ILIM_STATE	SW3_UV_STATE	SW3_OV_STATE
SW4	SW4_ILIM_STATE	SW4_UV_STATE	SW4_OV_STATE
SW5	SW5_ILIM_STATE	SW5_UV_STATE	SW5_OV_STATE
LDO1	LDO1_ILIM_STATE	LDO1_UV_STATE	LDO1_OV_STATE
LDO2	LDO2_ILIM_STATE	LDO2_UV_STATE	LDO2_OV_STATE

ILIM faults are debounced for 1.0 ms before they can be detected as a fault condition. If the regulator is programmed to disable upon an ILIM condition, the regulator turns off as soon as the ILIM condition is detected.

OV/UV faults are debounced as programmed by the OV_DB and UV_DB registers, before they are detected as a fault condition. If the regulator is programmed to disable upon an OV or UV, the regulator turns off if the fault persists for longer than 300 μs after the OV/UV fault has been detected.

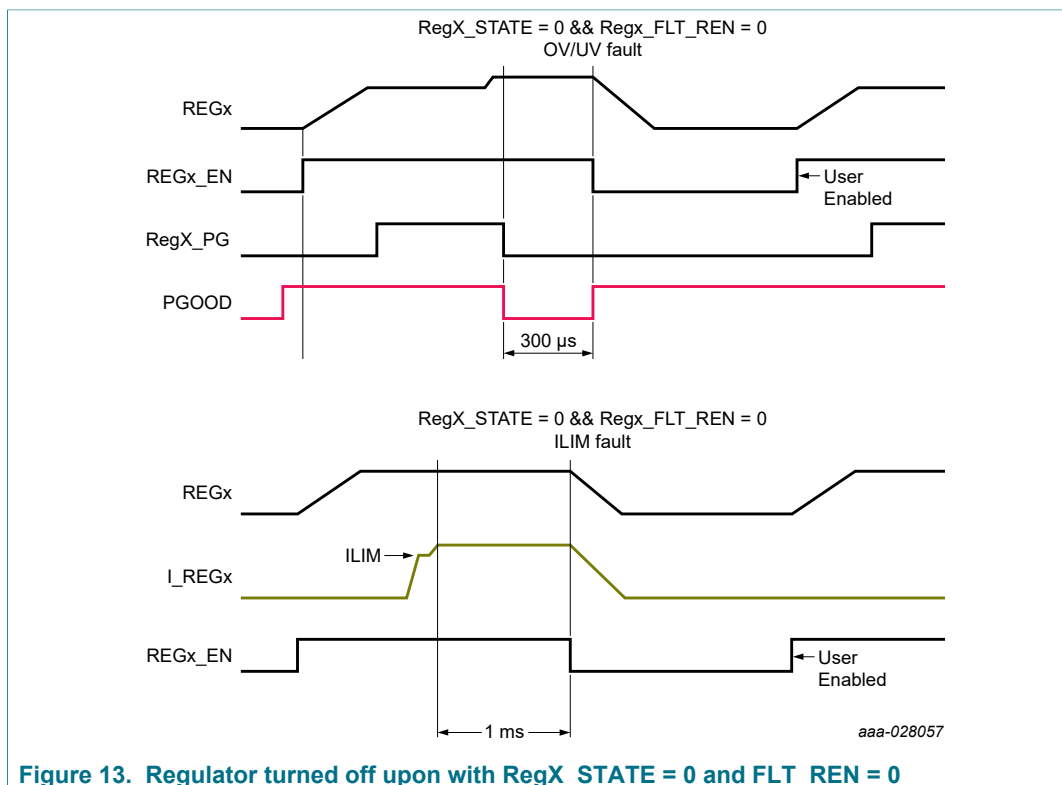

Figure 13. Regulator turned off upon with RegX_STATE = 0 and FLT_REN = 0

When a regulator is programmed to disable upon an OV, UV, or ILIM fault, a bit is provided to decide whether a regulator can return to its previous configuration or remain disabled when the fault condition is cleared.

SWx_FLT_REN / LDOx_FLT_REN

- 0 = regulator remains disabled after the fault condition is cleared or no longer present
- 1 = regulator returns to its previous state if fault condition is cleared

If a regulator is programmed to remain disabled after clearing the fault condition, the MCU can turn it back on during the system-on states by toggling Off and On, the corresponding mode/enable bits.

When the bit SW_x_FLT_REN = 1, if a regulator is programmed to turn off upon an OV, UV or ILIM condition, the regulator returns to its previous state 500 μs after the fault condition is cleared. If the regulator is programmed to turn off upon an ILIM condition, the device may take up to 1.0 ms to debounce the ILIM condition removal, in addition to the 500 μs wait period to re-enable the regulator.

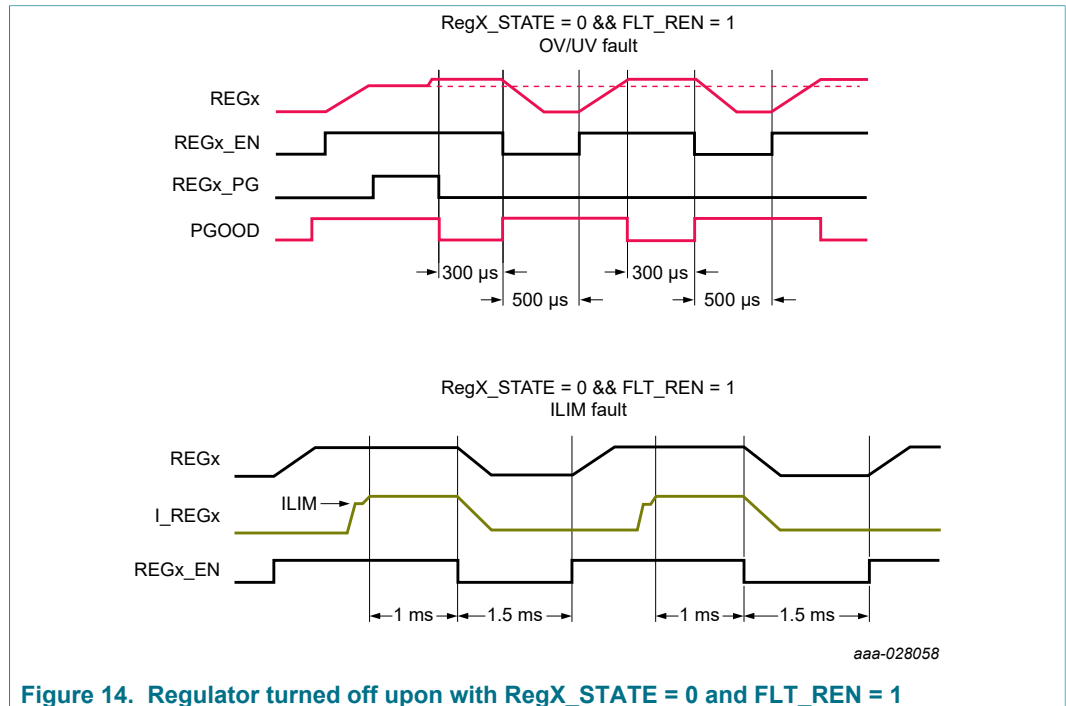

Figure 14. Regulator turned off upon with RegX_STATE = 0 and FLT_REN = 1

When the LDO2 is controlled by hardware using the LDO2EN pin and programmed to turn off upon an OV, UV or ILIM fault, the LDO2_FLT_REN bit still controls whether the regulator returns to its previous state or not regardless the state of the LDO2EN pin.

If LDO2 controlled by LDO2EN pin is instructed to remain disabled by the LDO2_FLT_REN bit, it recovers hardware control by modifying the LDO2_EN bits in the I²C register maps. See [Section 14.9.10 "LDO2EN"](#) for details on hardware control of LDO2 regulator.

To avoid fault cycling, a global fault counter is provided. Each time any of the external regulators encounter a fault event, the PF7100 compares the value of the FAULT_CNT[3:0] against the FAULT_MAX_CNT, and if it not equal, it increments the FAULT_CNT[3:0] and proceeds with the fault protection mechanism.

The processor is expected to read the counter value and reset it when the faults have been cleared and the device returns to a normal operation. If the processor does not reset the fault counter and it equals the FAULT_MAX_CNT[3:0] value, the state machine initiates a power down sequence.

The default value of the FAULT_MAX_CNT[3:0] is loaded from the OTP_FAULT_MAX_CNT[3:0] bits during the power up sequence.

When the FAULT_MAX_CNT[3:0] is set to 0x00, the system disables the turn-off events due to a Fault Counter maxing out.

7-channel power management integrated circuit for high performance applications

When a regulator experiences a fault event, a fault timer is started. While this timer is in progress, the expectation is that the processor takes actions to clear the fault. For example, it could reduce its load in the event of a current limit fault, or turn off the regulator in the event of an overvoltage fault.

If the fault clears before the timer expires, the state machine resumes the normal operation, and the fault timer gets reset. If the fault does not clear before the timer expires, a power down sequence is initiated to turn off the voltage regulators.

The default value of the fault timer is set by the OTP_TIMER_FAULT[3:0], however the duration of the fault timer can be changed during the system-on states by modifying the TIMER_FAULT[3:0] bits in the I²C registers.

Table 25. Fault timer register configuration

OTP bits OTP_TIMER_FAULT [3:0]	Functional bits TIMER_FAULT [3:0]	Timer value (ms)
0000	0000	1
0001	0001	2
0010	0010	4
0011	0011	8
0100	0100	16
0101	0101	32
0110	0110	64
0111	0111	128
1000	1000	256
1001	1001	512
1010	1010	1024
1011	1011	2056
1100	1100	Reserved
1101	1101	Reserved
1110	1110	Reserved
1111	1111	Disabled

Each voltage regulator has a dedicated I²C bit that is used to bypass the fault detection mechanism for each specific fault.

SW_x_ILIM_BYPASS / LDO_x_ILIM_BYPASS

- 0 = ILIM protection enabled
- 1 = ILIM fault bypassed

SW_x_OV_BYPASS / LDO_x_OV_BYPASS

- 0 = OV protection enabled
- 1 = OV fault bypassed

SW_x_UV_BYPASS / LDO_x_UV_BYPASS

- 0 = UV protection enabled
- 1 = UV fault bypassed

Table 26. Fault bypass bits

Regulator	Bit to bypass a current limit	Bit to bypass an undervoltage	Bit to bypass an overvoltage
SW1	SW1_ILIM_BYPASS	SW1_UV_BYPASS	SW1_OV_BYPASS
SW2	SW2_ILIM_BYPASS	SW2_UV_BYPASS	SW2_OV_BYPASS
SW3	SW3_ILIM_BYPASS	SW3_UV_BYPASS	SW3_OV_BYPASS
SW4	SW4_ILIM_BYPASS	SW4_UV_BYPASS	SW4_OV_BYPASS
SW5	SW5_ILIM_BYPASS	SW5_UV_BYPASS	SW5_OV_BYPASS
LDO1	LDO1_ILIM_BYPASS	LDO1_UV_BYPASS	LDO1_OV_BYPASS
LDO2	LDO2_ILIM_BYPASS	LDO2_UV_BYPASS	LDO2_OV_BYPASS

The default value of the OV_BYPASS, UV_BYPASS and ILIM_BYPASS bits upon power up can be configured by their corresponding OTP bits.

Bypassing the fault detection prevents the specific fault from starting any of the protective mechanisms:

- Increment the counter
- Start the fault timer
- Disable the regulator if the corresponding _STATE bit is 0
- OV / UV condition asserting the PGOOD pin low

When a fault is bypassed, the corresponding interrupt bit is still set and the INTB pin is asserted, provided the interrupt has not been masked.

14.7.1 Fault monitoring during power up state

An OTP bit is provided to select whether the output of the switching regulators is verified during the power up sequence and used as a gating condition to release the RESETBMCU or not.

- When OTP_PG_CHECK = 0, the output voltage of the regulators is not checked during the power up sequence and power good indication is not required to de-assert the RESETBMCU. In this scenario, the OV/UV monitors are masked until RESETBMCU is released; after this event, all regulators may start checking for faults after their corresponding blanking period.
- When OTP_PG_CHECK = 1, the output voltage of the regulators is verified during the power up sequence and a power good condition is required to release the RESETBMCU.

When OTP_PG_CHECK = 1, OV and UV faults during the power up sequence are reported based on the internal PG (Power Good) signals of the corresponding external regulator. The PGOOD pin can be used as an external indicator of an OV/UV failure when the RESETBMCU is ready to be de-asserted and it has been configured in the PGOOD mode. See [Section 14.9.8 "PGOOD"](#) for details on PGOOD pin operation and configuration.

Regardless of the PGOOD pin configured as a power good indicator or not, the PF7100 masks the detection of an OV/UV failure until RESETBMCU is ready to be released, at this point the device checks for any OV/UV condition for the regulators turned on so far. If all regulators powered up before or in the same sequence slot than RESETBMCU are in regulation, RESETBMCU is de-asserted and the power up sequence can continue as shown in [Figure 15](#).

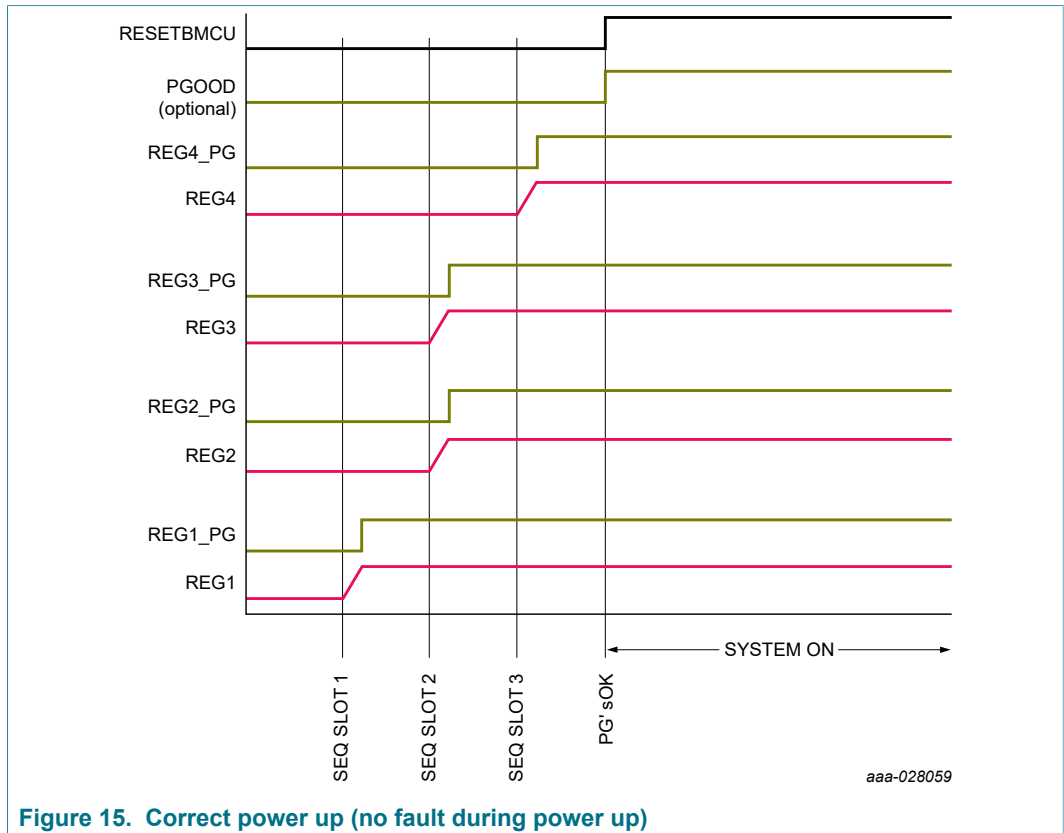
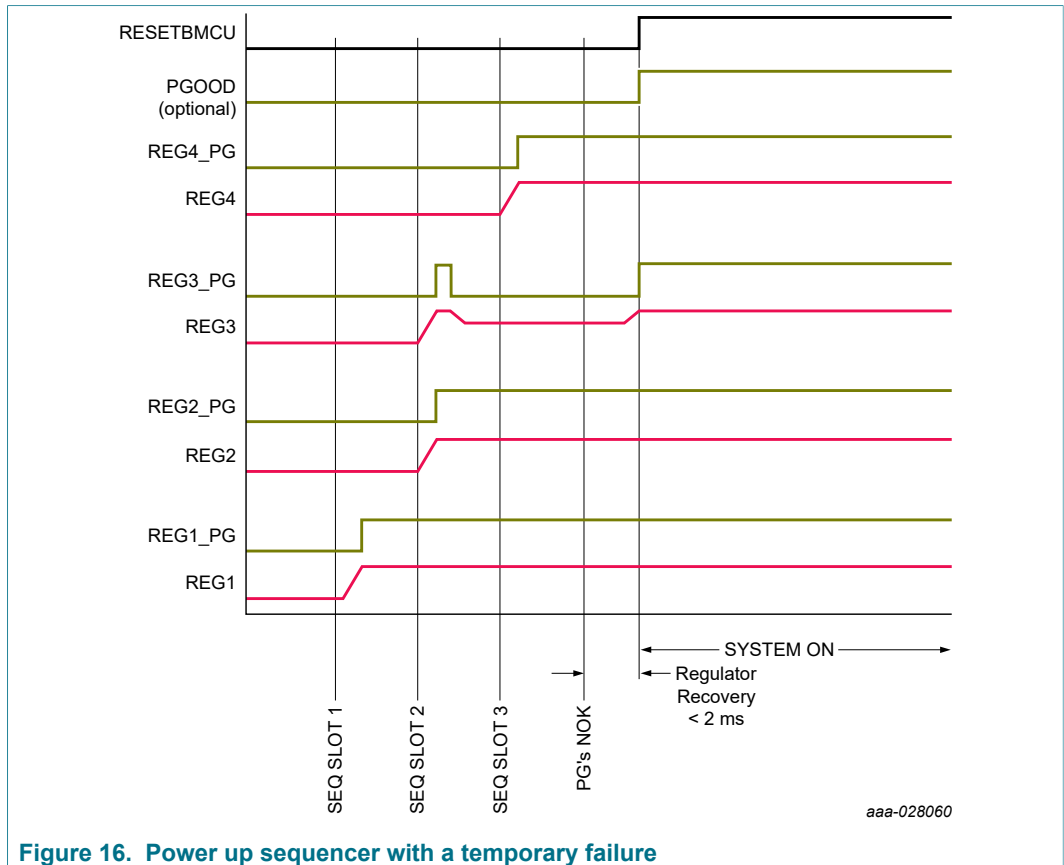

Figure 15. Correct power up (no fault during power up)

If any of the regulators are powered up before RESETBMCU is out of regulator, RESETBMCU is not de-asserted and the power up sequence is stopped for up to 2.0 ms. If the fault is cleared and all internal PG signals are asserted within the 2.0 ms timer, RESETBMCU is de-asserted and the power up sequence continues where it stopped as shown in [Figure 16](#).



If the faulty condition is not cleared within the 2.0 ms timer, the power up sequence is aborted and the PF7100 turns off all voltage regulators enabled so far as shown in [Figure 17](#).

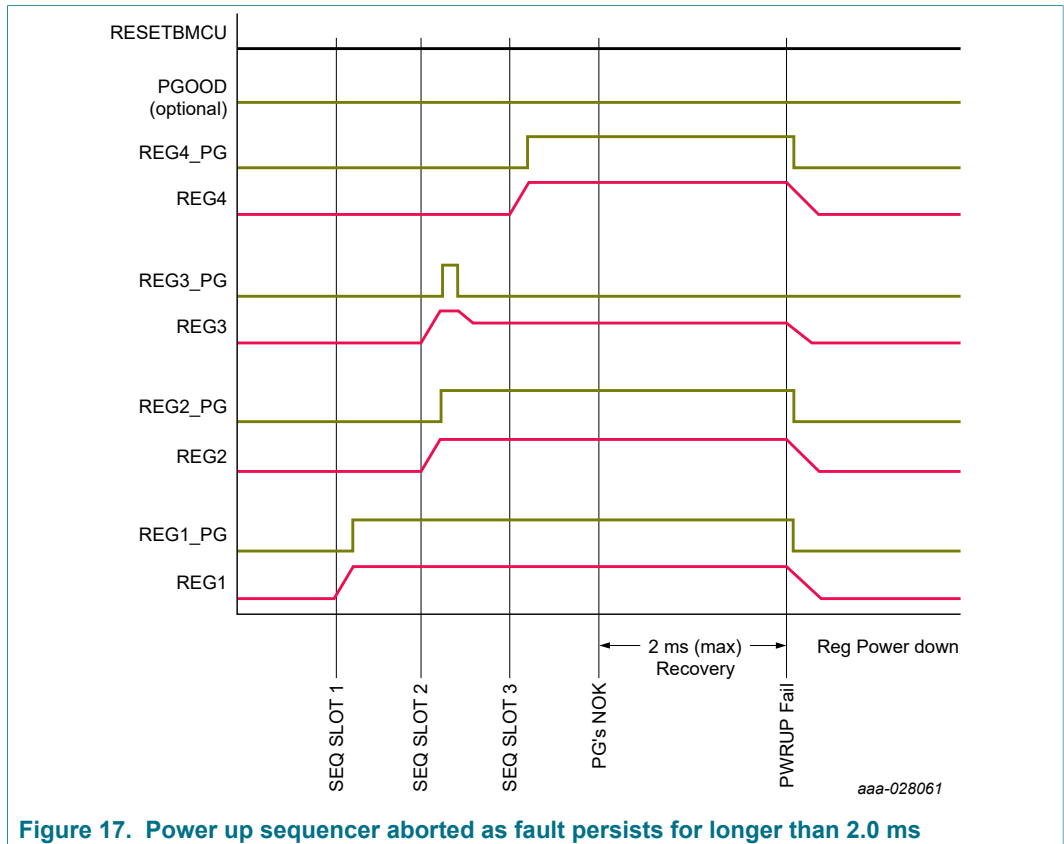

Figure 17. Power up sequencer aborted as fault persists for longer than 2.0 ms

Supplies enabled after RESETBMCU are checked for OV, UV, and ILIM faults after each of them is enabled. If an OV, UV or ILIM condition is present, the PF7100 starts a fault detection and protection mechanism as described in [Section 14.7 "Fault detection"](#). At this point, the MCU should be able to read the interrupt and react upon a fault event as defined by the system.

When `OTP_PG_CHECK = 1`, if PGOOD is used as a GPIO, it may be released at any time in the power up sequence as long as the RESETBMCU is released after one or more of the SW or LDO regulators.

If a regulator fault occurs after RESETBMCU is de-asserted but before the power up sequence is finalized, the power up sequence continues to turn on the remaining regulators as configured, even if a fault detection mechanism is active on an earlier regulator.

14.8 Interrupt management

The MCU is notified of any interrupt through the INTB pin and various interrupt registers.

The interrupt registers are composed by three types of bits to help manage all the interrupt request in the PF7100:

- The interrupt latch `XXXX_I`: this bit is set when the corresponding interrupt event occurs. It can be read at any time, and is cleared by writing a 1 to the bit.
- The mask bit `XXXX_M`: this bit controls whether a given interrupt latch pulls the INTB pin low or not.
- When the mask bit is 1, the interrupt latch does not control the INTB pin.

7-channel power management integrated circuit for high performance applications

- When the mask bit is 0, INTB pin is pulled low as long as the corresponding latch bit is set.
- The sense bit XXXX_S: if available, the sense bit provides the actual status of the signal triggering the interrupt.

The INTB pin is a reflection of an “OR” logic of all the interrupt status bits which control the pin.

Interrupts are stored in two levels on the interrupts registers. At first level, the SYS_INT register provides information about the Interrupt register that originated the interrupt event.

The corresponding SYS_INT bits are set as long as the INTB pin is programmed to assert with any of the interrupt bits of the respective interrupt registers.

- STATUS1_I: this bit is set when the interrupt is generated within the INT STATUS1 register
- STATUS2_I: this bit is set when the interrupt is generated within the INT STATUS2 register
- MODE_I: this bit is set when the interrupt is generated within the SW MODE INT register
- ILIM_I: this bit is set when the interrupt is generated within any of the SW ILIM INT or LDO ILIM INT registers
- UV_I: this bit is set when the interrupt is generated within any of the SW UV INT or LDO UV INT registers
- OV_I: this bit is set when the interrupt is generated within any of the SW OV INT or LDO OV INT registers
- PWRON_I: this bit is set when the interrupt is generated within the PWRON INT register.
- EWARN_I: is set when an early warning event occurs to indicate an imminent shutdown.

The SYS_INT bits are set when the INTB pin is asserted by any of the second level interrupt bits that have not been masked in their corresponding mask registers. When the second level interrupt bit is cleared, the corresponding first level interrupt bit on the SYS_INT register is cleared automatically.

The INTB pin remains asserted if any of the first level interrupts bit is set, and is de-asserted only when all the unmasked second level interrupts are cleared and thus all the first level interrupts are cleared as well.

At second level, the remaining registers provide the exact source for the interrupt event.

[Table 27](#) shows a summary of the interrupt latch, mask, and sense pins available on the PF7100.

Table 27. Interrupt registers

Register name	BIT7	BIT6	BIT5	BIT4	BIT3	BIT2	BIT1	BIT0
INT STATUS1	SDWN_I	FREQ_RDY_I	CRC_I	PWRUP_I	PWRDN_I	XINTB_I	FSOB_I	VIN_OVLO_I
INT MASK1	SDWN_M	FREQ_RDY_M	CRC_M	PWRUP_M	PWRDN_M	XINTB_M	FSOB_M	VIN_OVLO_M
INT SENSE1	—	—	—	—	—	XINTB_S	FSOB_S	VIN_OVLO_S
THERM INT	WDI_I	FSYNC_FLT_I	THERM_155_I	THERM_140_I	THERM_125_I	THERM_110_I	THERM_95_I	THERM_80_I
THERM MASK	WDI_M	FSYNC_FLT_M	THERM_155_M	THERM_140_M	THERM_125_M	THERM_110_M	THERM_95_M	THERM_80_M
THERM SENSE	WDI_S	FSYNC_FLT_S	THERM_155_S	THERM_140_S	THERM_125_S	THERM_110_S	THERM_95_S	THERM_80_S
SW MODE INT	—	SW5_MODE_I	—	—	SW4_MODE_I	SW3_MODE_I	SW2_MODE_I	SW1_MODE_I
SW MODE MASK	—	SW5_MODE_M	—	—	SW4_MODE_M	SW3_MODE_M	SW2_MODE_M	SW1_MODE_M
SW ILIM INT	—	SW5_ILIM_I	—	—	SW4_ILIM_I	SW3_ILIM_I	SW2_ILIM_I	SW1_ILIM_I
SW ILIM MASK	—	SW5_ILIM_M	—	—	SW4_ILIM_M	SW3_ILIM_M	SW2_ILIM_M	SW1_ILIM_M

7-channel power management integrated circuit for high performance applications

Register name	BIT7	BIT6	BIT5	BIT4	BIT3	BIT2	BIT1	BIT0
SW ILIM SENSE	—	SW5_ILIM_S	—	—	SW4_ILIM_S	SW3_ILIM_S	SW2_ILIM_S	SW1_ILIM_S
LDO ILIM INT	—	—	—	—	—	—	LDO2_ILIM_I	LDO1_ILIM_I
LDO ILIM MASK	—	—	—	—	—	—	LDO2_ILIM_M	LDO1_ILIM_M
LDO ILIM SENSE	—	—	—	—	—	—	LDO2_ILIM_S	LDO1_ILIM_S
SW UV INT	—	SW5_UV_I	—	—	SW4_UV_I	SW3_UV_I	SW2_UV_I	SW1_UV_I
SW UV MASK	—	SW5_UV_M	—	—	SW4_UV_M	SW3_UV_M	SW2_UV_M	SW1_UV_M
SW UV SENSE	—	SW5_UV_S	—	—	SW4_UV_S	SW3_UV_S	SW2_UV_S	SW1_UV_S
SW OV INT	—	SW5_OV_I	—	—	SW4_OV_I	SW3_OV_I	SW2_OV_I	SW1_OV_I
SW OV MASK	—	SW5_OV_M	—	—	SW4_OV_M	SW3_OV_M	SW2_OV_M	SW1_OV_M
SW OV SENSE	—	SW5_OV_S	—	—	SW4_OV_S	SW3_OV_S	SW2_OV_S	SW1_OV_S
LDO UV INT	—	—	—	—	—	—	LDO2_UV_I	LDO1_UV_I
LDO UV MASK	—	—	—	—	—	—	LDO2_UV_M	LDO1_UV_M
LDO UV SENSE	—	—	—	—	—	—	LDO2_UV_S	LDO1_UV_S
LDO OV INT	—	—	—	—	—	—	LDO2_OV_I	LDO1_OV_I
LDO OV MASK	—	—	—	—	—	—	LDO2_OV_M	LDO1_OV_M
LDO OV SENSE	—	—	—	—	—	—	LDO2_OV_S	LDO1_OV_S
PWRON INT	BGMON_I	PWRON_8S_I	PWRON_4S_I	PRON_3S_I	PWRON_2S_I	PWRON_1S_I	PWRON_REL_I	PWRON_PUSH_I
PWRON MASK	BGMON_M	PWRON_8S_M	PWRON_4S_M	PRON_3S_M	PWRON_2S_M	PWRON_1S_M	PWRON_REL_M	PWRON_PUSH_M
PWRON SENSE	BGMON_S	—	—	—	—	—	—	PWRON_S
SYS INT	EWARN_I	PWRON_I	OV_I	UV_I	ILIM_I	MODE_I	STATUS2_I	STATUS1_I

14.9 I/O interface pins

The PF7100 PMIC is fully programmable via the I²C interface. Additional communication between MCU, PF7100, and other companion PMIC is provided by direct logic interfacing including INTB, RESETBMCU, PGOOD, among other pins.

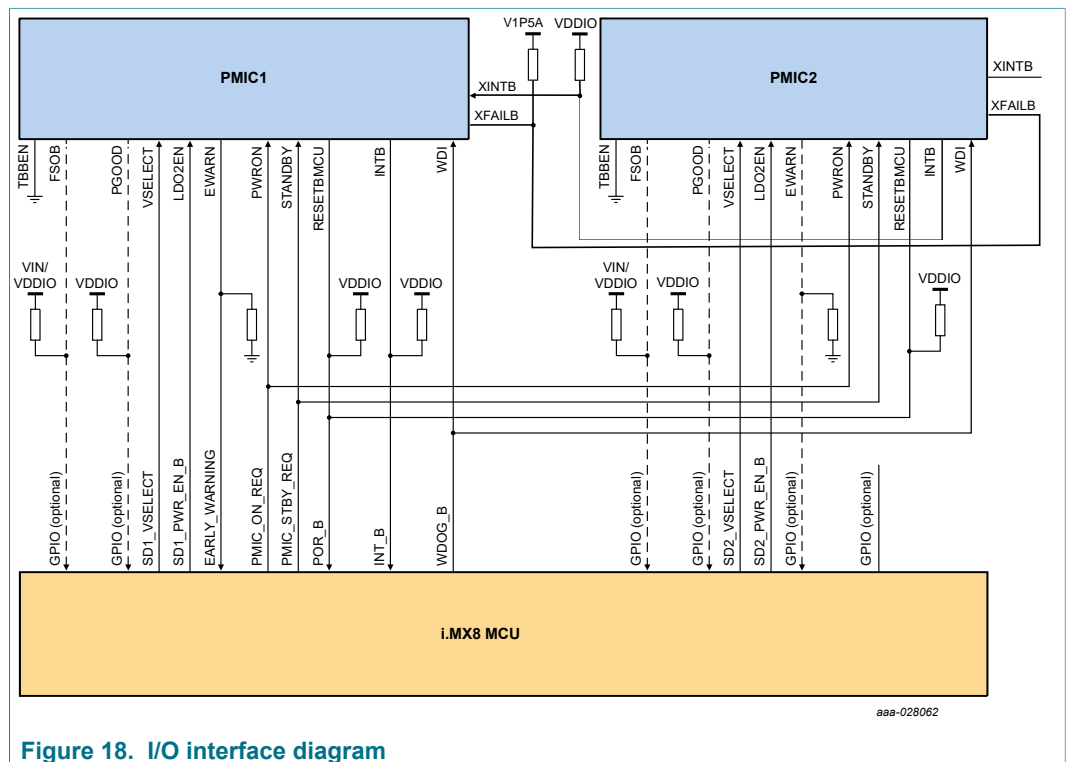

Figure 18. I/O interface diagram

Table 28. I/O electrical specifications

Symbol	Parameter	Min	Typ	Max	Unit
PWRON_V _{IL}	PWRON low input voltage	—	—	0.4	V

7-channel power management integrated circuit for high performance applications

Symbol	Parameter	Min	Typ	Max	Unit
PWRON_ V _{IH}	PWRON high input voltage	1.4	—	5.5	V
STANDBY_ V _{IL}	STANDBY low input voltage	—	—	0.4	V
STANDBY_ V _{IH}	STANDBY high input voltage	1.4	—	5.5	V
RESETBMCU_ V _{OL}	RESETBMCU low output voltage -10 mA load current	0	—	0.4	V
INTB_ V _{OL}	INTB low output voltage -10 mA load current	0	—	0.4	V
XINTB_ V _{IL}	XINTB low input voltage	—	—	0.3*VDDIO	V
XINTB_ V _{IH}	XINTB high input voltage	0.7*VDDIO	—	5.5	V
R _{XINTB_PU}	XINTB internal pullup resistance	0.475	1.0	—	MΩ
WDI_ V _{IL}	WDI low input voltage	—	—	0.3*VDDIO	V
WDI_ V _{IH}	WDI high input voltage	0.7*VDDIO	—	5.5	V
R _{WDI_PD}	WDI internal pulldown resistance	0.475	1.0	—	MΩ
EWARN_ V _{OH}	EWARN high output voltage 2.0 mA load current	VDDIO - 0.5	—	VDDIO	V
PGOOD_ V _{OL}	PGOOD low output voltage -10 mA load current	0	—	0.4	V
VSELECT_ V _{IL}	VSELECT low input voltage	—	—	0.3*VDDIO	V
VSELECT_ V _{IH}	VSELECT high input voltage	0.7*VDDIO	—	5.5	V
R _{VSELECT_PD}	VSELECT internal pulldown resistance	0.475	1.0	—	MΩ
LDO2EN_ V _{IL}	LDO2EN low input voltage	—	—	0.3*VDDIO	V
LDO2EN_ V _{IH}	LDO2EN high input voltage	0.7*VDDIO	—	5.5	V
R _{LDO2EN_PD}	LDO2EN internal pulldown resistance	0.475	1.0	—	MΩ
TBBEN_ V _{IL}	TBBEN low input voltage	—	—	0.4	V
TBBEN_ V _{IH}	TBBEN high input voltage	1.4	—	5.5	V
R _{TBBEN_PD}	TBBEN internal pulldown resistance	0.475	1.0	—	MΩ
XFAILB_ V _{IL}	XFAILB low input voltage	—	—	0.4	V
XFAILB_ V _{IH}	XFAILB high input voltage	1.4	—	5.5	V
XFAILB_ V _{OH}	XFAILB high output voltage Pulled-up to V1P5A	V1P5A - 0.5	—	—	V
XFAILB_ V _{OL}	XFAILB low output voltage -10 mA load current	0	—	0.4	V
FSOB_ V _{OL}	FSOB low output voltage -10 mA	0	—	0.4	V
SCL_ V _{IL}	SCL low input voltage	—	—	0.3*VDDIO	V
SCL_ V _{IH}	SCL high input voltage	0.7*VDDIO	—	VDDIO	V
SDA_ V _{IL}	SDA low input voltage	—	—	0.3*VDDIO	V
SDA_ V _{IH}	SDA high input voltage	0.7*VDDIO	—	VDDIO	V
SDA_ V _{OL}	SDA low output voltage -20 mA load current	0	—	0.4	V

14.9.1 PWRON

PWRON is an input signal to the IC that acts as a power up event signal in the PF7100.

7-channel power management integrated circuit for high performance applications

The PWRON pin has two modes of operations as programmed by the OTP_PWRON_MODE bit.

When OTP_PWRON_MODE = 0, the PWRON pin operates in level sensitive mode. In this mode, the device is in the corresponding OFF mode when the PWRON pin is pulled low. Pulling the PWRON pin high is a necessary condition to generate a power on event.

PWRON may be pulled up to VSNVSx or VIN with an external 100 kΩ resistor, if device is intended to come up automatically with VIN application. See [Section 14.5 "Power up"](#) for details on power up requirements.

When OTP_PWRON_MODE = 1, the PWRON pin operates in edge sensitive mode. In this mode, PWRON is used as an input from a push button connected to the PMIC.

When the switch is not pressed, the PWRON pin is pulled up to VIN externally through a 100 kΩ resistor. When the switch is pressed, the PWRON pin should be shorted to ground. The PWRON_S bit is high whenever the PWRON pin is at logic 0 and is low whenever the PWRON pin is at logic 1.

The PWRON pin has a programmable debounce on the rising and falling edges as shown in [Table 29](#).

Table 29. PWRON debounce configuration in edge detection mode

Bits	Value	Falling edge debounce (ms)	Rising edge debounce (ms)
PWRON_DBNC[1:0]	00	32	32
PWRON_DBNC[1:0]	01	32	32
PWRON_DBNC[1:0]	10	125	32
PWRON_DBNC[1:0]	11	750	32

The default value for the power on debounce is set by the OTP_PWRON_DBNC[1:0] bits.

Pressing the PWRON switch for longer than the debounce time starts a power on event as well as generate interrupts which the processor may use to initiate PMIC state transitions.

During the system-on states, when the PWRON button is pushed (logic 0) for longer than the debounce setting, the PWRON_PUSH_I interrupt is generated. When the PWRON button is released (logic 1) for longer than the debounce setting, the PWRON_REL_I interrupt is generated.

The PWRON_1S_I, PWRON_2S_I, PWRON_3S_I, PWRON_4S_I and PWRON_8S_I interrupts are generated when the PWRON pin is held low for longer than 1, 2, 3, 4 and 8 seconds respectively.

If PWRON_RST_EN = 1, pressing the PWRON for longer than the delay programmed by TRESET[1:0] forces a PMIC reset. A PMIC reset initiates a power down sequence, wait for 30 μs to allow all supplies to discharge and then it powers back up with the default OTP configuration.

If PWRON_RST_EN = 0, the device starts a turn off event after push button is pressed for longer than TRESET[1:0].

Table 30. TRESET configuration

TRESET[1:0]	Time to reset
00	2 s
01	4 s
10	8 s

7-channel power management integrated circuit for high performance applications

TRESET[1:0]	Time to reset
11	16 s

The default value of the TRESET delay is programmable through the OTP_TRESET[1:0] bits.

14.9.2 STANDBY

STANDBY is an input signal to the IC, when this pin is asserted, the device enters the standby mode and when de-asserted, the part exits standby mode.

STANDBY can be configured as active high or active low using the STANDBYINV bit.

Table 31. Standby pin polarity control

STANDBY (pin)	STANDBYINV (I ² C bit)	STANDBY control
0	0	Not in standby mode
0	1	In standby mode
1	0	In standby mode
1	1	Not in standby mode

14.9.3 RESETBMCU

RESETBMCU is an open-drain, active low output used to bring the processor (and peripherals) in and out of reset.

The time slot RESETBMCU is de-asserted during the power up sequence is programmed by the OTP_RESETBMCU_SEQ[7:0] bits, and it is a condition to enter the system-on states.

During the system-on states, the RESETBMCU is de-asserted (pulled high), and it is asserted (pulled low) as indicated in the power down sequence, when a system power down or reset is initiated.

In the application, RESETBMCU can be pulled up to VDDIO or VSNVSx by a 100 kΩ external resistor.

14.9.4 INTB

INTB is an open-drain, active low output. This pin is asserted (pulled low) when any interrupt occurs, if the interrupt is not masked.

INTB is de-asserted after the corresponding interrupt latch is cleared by software, which requires writing a "1" to the interrupt bit.

An INTB_TEST bit is provided to allow a manual test of the INTB pin. When INTB_TEST is set to 1, the interrupt pin asserts for 100 μs and then de-asserts to its normal state. The INTB_TEST bit self-clears to 0 automatically after the test pulse is generated.

In the application, INTB can be pulled up to VDDIO with an external 100 kΩ resistor.

14.9.5 XINTB

XINTB is an input pin used to receive an external interrupt and trigger an interrupt event on the PF7100. It is meant to interact with the INTB pin of a companion PMIC, in order to simplify MCU interaction to identify the source of the interrupt.

A high to low transition on the XINTB pin sets the XINTB_I interrupt bit and causes the INTB to be asserted, provided the interrupt is not masked.

The XINTB_S bit follows the actual status of the XINTB pin even when the XINTB_I has been cleared or the interrupt has been masked.

This pin is internally pulled up to VDDIO with a 1.0 MΩ resistor; therefore, it can be left unconnected when the XINTB is not used.

14.9.6 WDI

WDI is an input pin to the PF7100 and is intended to operate as an external watchdog monitor.

When the WDI pin is connected to the watchdog output of the processor, this pin is used to detect a pulse to indicate that a watchdog event is requested by the processor. When the WDI pin is asserted, the device starts a watchdog event to place the PMIC outputs in a default known state.

The WDI pin is monitored during the system-on states. In the OFF modes and during the power up sequence, the WDI pin is masked until RESETBMCU is de-asserted.

The WDI can be configured to assert on the rising or the falling edge using the OTP_WDI_INV bit.

- When OTP_WDI_INV = 0, the device starts a WD event on the falling edge of the WDI.
- When OTP_WDI_INV = 1, the device starts a WD event on the rising edge of the WDI.

A 10 μs debounce filter is implemented on either rising or falling edge detection to prevent false WDI signals to start a watchdog event.

The OTP_WDI_MODE bit allows the WDI pin to react in two different ways:

- When OTP_WDI_MODE = 1, a WDI asserted performs a hard WD reset.
- When OTP_WDI_MODE = 0, a WDI asserted performs a soft WD reset.

The WDI_STBY_ACTIVE bit allows the WDI pin to generate a watchdog event during the standby state.

- When WDI_STBY_ACTIVE = 0, asserting the WDI does not generate a watchdog event during the standby state.
- When WDI_STBY_ACTIVE = 1, asserting the WDI starts a watchdog event during the standby state.

The OTP_WDI_STBY_ACTIVE is used to configure whether the WDI is active in the standby state or not by default upon power up.

See [Section 15.10 "Watchdog event management"](#) for details on watchdog event.

14.9.7 EWARN

EWARN is an active high output, used to notify that an imminent power failure is about to occur. It should be pulled down to GND by a 100 kΩ resistor.

When a power down is initiated due to a fault, the EWARN pin is asserted before the device starts powering down as defined by the EWARN_TIME[1:0] bits in order to allow the system to prepare for the imminent shutdown.

The following faults cause the EWARN pin to be asserted:

- Fault timer expired

- FAULT_CNT = FAULT_MAX_CNT
- Thermal shutdown $t_j > TSD$
- VIN_OVLO event when VIN_OVLO_SDWN = 1

Table 32. EWARN time configuration

OTP_EWARN_TIME[1:0]	EWARN delay time
00	100 μ s
01	5 ms
10	20 ms
11	50 ms

When the EWARN pin is asserted, an interrupt is generated and the EWARN_I bit is set to announce to the system of an imminent shutdown event.

In the OFF modes, EWARN remains de-asserted (pulled low).

In the event of a power loss (VIN removed), the EWARN pin is asserted upon crossing the V_{WARNTH} threshold to notify to the processor that VIN may be lost and allow some time to prepare for the power loss.

Table 33. Early warning threshold

Symbol	Parameter	Min	Typ	Max	Unit
V_{WARNTH}	Early warning threshold	2.7	2.8	2.9	V

14.9.8 PGOOD

PGOOD is an open-drain output programmable as a Power Good indicator pin or GPO. In the application, PGOOD can be pulled up to VDDIO with a 100 k Ω resistor.

When OTP_PG_ACTIVE = 0, the PGOOD pin is used as a general-purpose output.

As a GPO, during the run state, the state of the pin is controlled by the RUN_PG_GPO bit in the functional I²C registers:

- When RUN_PG_GPO = 1, the PGOOD pin is high
- When RUN_PG_GPO = 0, the PGOOD pin is low

During the standby state, the state of the pin is controlled by the STBY_PG_GPO bit in the functional I²C registers:

- When STBY_PG_GPO = 1, the PGOOD pin is high
- When STBY_PG_GPO = 0, the PGOOD pin is low

When used as a GPO, the PGOOD pin can be enabled high as part of the power up sequence as programmed by the OTP_SEQ_TBASE[1:0] and the OTP_PGOOD_SEQ[7:0] bits. If enabled as part of the power up sequence, both the RUN_PG_GPO and STBY_PG_GPO bits are loaded with 1, otherwise they are loaded with 0 upon power up.

When OTP_PG_ACTIVE = 1, the PGOOD pin is in Power good (PG) mode and it acts as a PGOOD indicator for the selected output voltages in the PF7100.

There is an individual PG monitor for every regulator. Each monitor provides an internal PG signal that can be selected to control the status of the PGOOD pin upon an OV or UV condition when the corresponding SWxPG_EN / LDOxPG_EN bits are set. The status of the PGOOD pin is a logic AND function of the internal PG signals of the selected monitors.

7-channel power management integrated circuit for high performance applications

- When the PG_EN = 1, the corresponding regulator becomes part of the AND function that controls the PGOOD pin.
- When the PG_EN = 0, the corresponding regulator does not control the status of the PGOOD pin.

The PGOOD pin is pulled low when any of the selected regulator outputs falls above or below the programmed OV/UV thresholds and the corresponding OV/UV interrupt is generated. If the faulty condition is removed, the corresponding OV_S/UV_S bit goes low to indicate the output is back in regulation, however, the interrupt remains latched until it is cleared.

The actual condition causing the interrupt (OV, UV) can be read in the fault interrupt registers. For more details on handling interrupts, see [Section 14.8 "Interrupt management"](#).

When a particular regulator is disabled (via OTP, or I²C, or by change in state of PMIC such as going to standby mode), it no longer controls the PGOOD pin.

In the OFF modes and during the power up sequence, the PGOOD pin is held low until RESETBMCU is ready to be released, at this point, the PG monitors are unmasked and the PGOOD pin is released high if all the internal PG monitors are in regulation. In the event that one or more outputs are not in regulation by the time RESETBMCU is ready to de-assert, the PGOOD pin is held low and the PF7100 performs the corresponding fault protection mechanism as described in [Section 14.7.1 "Fault monitoring during power up state"](#).

14.9.9 VSELECT

VSELECT is an input pin used to select the output voltage of LDO2 when bit VSELECT_EN = 1.

- When VSELECT pin is low, the LDO2 output is programmed to 3.3 V.
- When VSELECT pin is high, the LDO2 output is programmed to 1.8 V.

When VSELECT_EN = 0, the output of LDO2 is given by the VLDO2_RUN[3:0] bits.

When the PF7100 is in the standby mode, the output voltage of LDO2 follows the configuration as selected by the VLDO2_STBY[3:0] bits, regardless of the value of VSELECT_EN bit.

The default value of the VSELECT_EN bit is programmed by the OTP_VSELECT_EN bit in the OTP fuses.

A read-only bit is provided to monitor the actual state of the VSELECT pin. When the VSELECT pin is low, the VSELECT_S bit is 0 and when the VSELECT pin is high, the VSELECT_S bit is set to 1.

14.9.10 LDO2EN

LDO2EN is an input pin used to enable or disable LDO2 when the bit LDO2HW_EN = 1.

When LDO2HW_EN = 1, the status of LDO2 output can also be controlled by the LDO2_RUN_EN bit in the run mode or the LDO2_STBY_EN bit in the standby mode.

Table 34. LDO control in run or standby mode

LDO2EN pin	LDO2HW_EN bit	LDO2_RUN_EN LDO2_STBY_EN	LDO2 output
Do not care	0	0	Disabled

LDO2EN pin	LDO2HW_EN bit	LDO2_RUN_EN LDO2_STBY_EN	LDO2 output
Do not care	0	1	Enabled
Do not care	1	0	Disabled
Low	1	1	Disabled
High	1	1	Enabled

The default controlling mode for LDO2 is programmed by the OTP_LDO2HW_EN bit in the OTP fuses.

A read-only bit is provided to monitor the actual state of the LDO2EN pin. When the LDO2EN pin is low, the LDO2EN_S bit is 0 and when the LDO2EN pin is high, the LDO2EN_S bit is set to 1.

14.9.11 FSOB (safety output)

The FSOB pin is a configurable, active low, open-drain output used as a safety output to keep the system in a safe state upon a power up and/or during a specific failure event.

The FSOB pin is externally pulled up to VIN or VDDIO with a 470 kΩ resistor and it is de-asserted high in normal operation.

The FSOB pin can be configured in active safe state mode or fault safe state mode as programmed by the OTP_FSOB_ASS_EN bit in the OTP fuses.

On the PF7100 ASIL B devices, if the secure I2C write mechanism is enabled, all FSOB flags require a secure write for them to be cleared (write 1 to clear + RANDOM_GEN read + RANDOM_CHK write).

In the PF7100 QM devices, the OTP_FSOB_ASS_EN bit is not available, therefore it can only operate in fault safe state mode.

14.9.11.1 FSOB active safe state (ASIL B device only)

If the OTP_FSOB_ASS_EN = 1, the active safe state mode is enabled.

In the active safe state mode, the FSOB pin is programmed to be asserted low after OTP fuses are loaded and remain asserted as long as the PMIC is forced in a safe state.

In this mode of operation, the PMIC is forced in the Safe state in the following conditions:

- Any of the ABIST flags are set during the self-test at power up.
- The FSOB_WDI_NOK is set when FSOB is programmed to assert via the FSOB_WDI bit
- The FSOB_SFAULT_NOK is set when FSOB is programmed to assert via the FSOB_SOFTFAULT bit
- Hard WD Reset (voltage regulators and RESETBMCU reset)
- Device is in any of the Off modes and the RESETBMCU is asserted low
- The FSOB_ASS_NOK flag is asserted.

Each time the PMIC is forced into the safe state, the FSOB pin is asserted low, and the FSOB_ASS_NOK flag is set to 1, in order to keep the system in the safe state until the MCU verifies that it is safe to return to normal operation.

During the active safe state mode, the PMIC can exit the safe state and release the FSOB pin if the following conditions are met:

7-channel power management integrated circuit for high performance applications

- RESETBMCU is de-asserted (system on)
- All ABIST flags are all 0 (ABIST OK)
- No regulator faults are present
- The FSOB_WDI_NOK and/or FSOB_SFAULT_NOK faults are cleared if programmed to be set by the FSOB_WDI and FSOB_SOFTFAULT bits respectively.

A soft WD reset may also assert the FSOB pin only if programmed by the FSOB_WDI bit.

Likewise, the FSOB_SOFTFAULT bit can select whether the FSOB pin is asserted as soon as an OV, UV or ILIM fault is present even when this condition has not yet lead to a fault shutdown. In this scenario, the system is placed in a safe state while the MCU tries to clear the fault and command the PF7100 to come out of the safe state when all faults have been cleared.

14.9.11.2 FSOB fault safe state

If the OTP_FSOB_ASS_EN = 0, the active safe state mode is disabled and the FSOB operate in the fault safe state mode. In this mode, the FSOB pin may still be asserted if programmed by other fault events.

In the fault safe state mode, the FSOB is de-asserted by default, and can be asserted as programmed by the FSOB fault selection bits.

A bit is provided to enable the FSOB to be asserted when a regulator fault (OV, UV, ILIM) is present.

- If FSOB_SOFTFAULT = 0, the FSOB pin is not asserted by any OV, UV, or ILIM fault.
- If FSOB_SOFTFAULT = 1, an OV, UV, or ILIM fault on any of the regulators causes the FSOB pin to assert and remain asserted regardless of it being corrected or not, and also asserts the FSOB_SFAULT_NOK flag.

A bit is provided to enable the FSOB to be asserted when a WD reset occurs due to a WDI event.

- If FSOB_WDI = 0, the FSOB pin is not asserted by a WDI event.
- If FSOB_WDI = 1, a WDI event causes the FSOB pin to assert and the FSOB_WDI_NOK flag to be set.

A bit is provided to enable the FSOB to be asserted when a WD reset occurs due to an internal WD counter fault is present.

- If FSOB_WDC = 0, the FSOB pin is not asserted by a WD reset started by the internal WD counter.
- If FSOB_WDC = 1, a WD reset is started by the internal WD counter causing the FSOB pin to be asserted and the FSOB_WDC_NOK flag to be set.

A bit is provided to enable the FSOB to be asserted when a hard fault shutdown has occurred.

- If FSOB_HARDFAULT = 0, the FSOB pin is not asserted by a hard fault.
- If FSOB_HARDFAULT = 1, any of the hard fault shutdown events cause the FSOB pin to be asserted and the FSOB_HFAULT_NOK flag to be set.

Any of the following events are considered a hard fault shutdown:

- Fault timer expired
- FAULT_CNT = FAULT_MAX_CNT (regulator fault counter max out)
- WD_EVENT_CNT = WD_MAX_CNT (watchdog event counter max out)
- Power up failure

- Thermal shutdown

The FSOB pin is released when all the FSOB fault flags are cleared or VIN falls below the UVDET threshold.

14.9.12 TBBEN

The TBBEN is an input pin provided to allow the user to program the mirror registers in order to operate the device with a custom configuration as well as programming the default values on the OTP fuses.

- When TBBEN pin is pulled low to ground, the device is operating in normal mode.
- When TBBEN pin is pulled high to V1P5D, the device enables the TBB configuration mode.

See [Section 17 "OTP/TBB and hardwire default configurations"](#) for details on TBB and OTP operation.

When TBBEN pin is pulled high to V1P5D, the following conditions apply:

- The device uses a fixed I²C device address (0x08)
- Disable the watchdog operation, including WDI monitoring and internal watchdog timer
- Disable the CRC and I²C secure write mechanism while no power up event is present (TBB/OTP programming mode).

Disabling the watchdog operation may be required for in-line MCU programming where output voltages are required but watchdog operation should be completely disabled.

14.9.13 XFAILB

XFAILB is a bidirectional pin with an open-drain output used to synchronize the power up and power down sequences of two or more PMICs. It should be pulled up externally to V1P5A supply.

The OTP_XFAILB_EN bit is used to enable or disable the XFAILB mode of operation.

- When OTP_XFAILB_EN = 0, the XFAILB mode is disabled and any events on this pin are ignored.
- When OTP_XFAILB_EN = 1, the XFAILB Mode is enabled

When the XFAILB mode is enabled, and the PF7100 has a turn off event generated by an internal fault, the XFAILB pin is asserted low 20 μ s before starting the power down sequence.

A power down event caused by the following conditions asserts the XFAILB pin:

- Fault timer expired
- FAULT_CNT = FAULT_MAX_CNT (regulator fault counter max out)
- WD_EVENT_CNT = WD_MAX_CNT (watchdog event counter max out)
- Power up failure
- Thermal shutdown
- Hard WD event

The XFAILB pin is forced low during the OFF modes.

During the system-on states, if the XFAILB pin is externally pulled low, it detects an XFAIL event after a 20 μ s debounce. When an XFAIL event is detected, the XFAILB pin is asserted low internally and the device starts a power down sequence.

7-channel power management integrated circuit for high performance applications

If a PWRON event is present, the device starts a turn on event and proceeds to release the XFAILB pin when it is ready to start the power up sequence state. If the XFAILB pin is pulled down externally during the power up event, the PF7100 stops the power up sequence until the pin is no longer pulled down externally. This helps to synchronize the power up sequence allowing it to continue only when both PMICs are ready to initiate the power up sequence.

A hard WD event sets the XFAILB pin 20 μ s before it starts its power down sequence. After all regulators outputs have been turned off, the device releases the XFAILB pin internally after a 30 μ s delay, proceeds to load the default OTP configuration, and waits for the XFAILB pin to be released externally before it can restart the power up sequence.

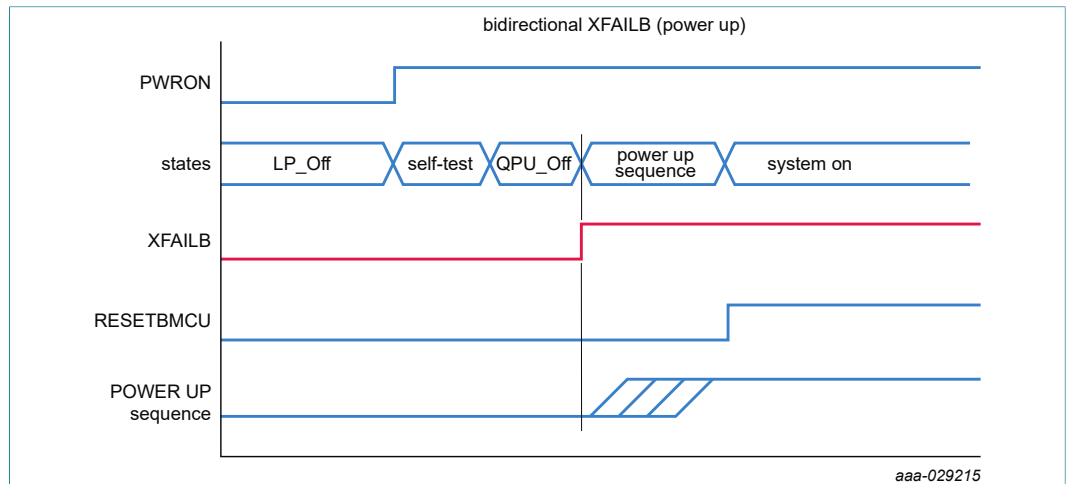

Figure 19. XFAILB behavior during a power up sequence

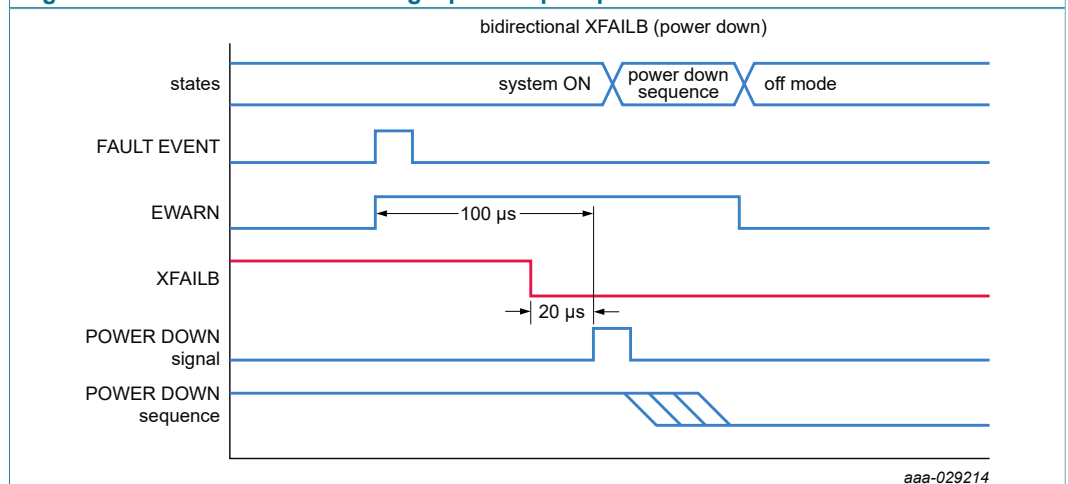

Figure 20. XFAILB behavior during a power down sequence

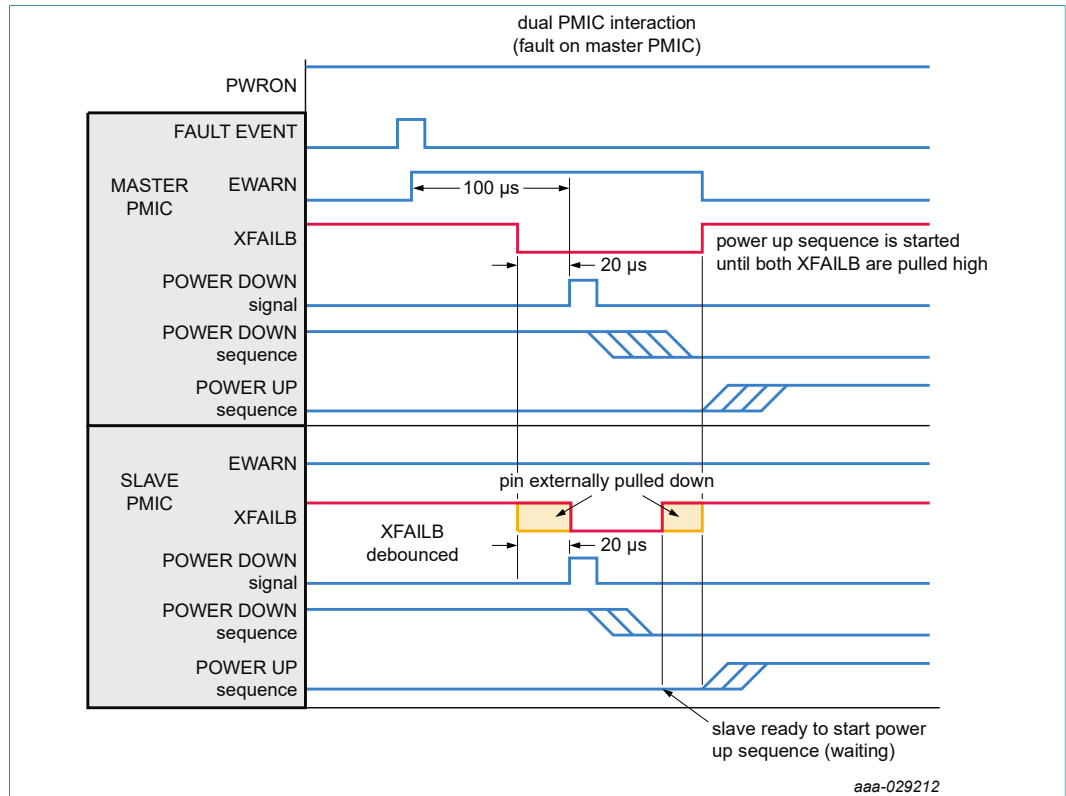

Figure 21. Behavior during an external XFAILB event

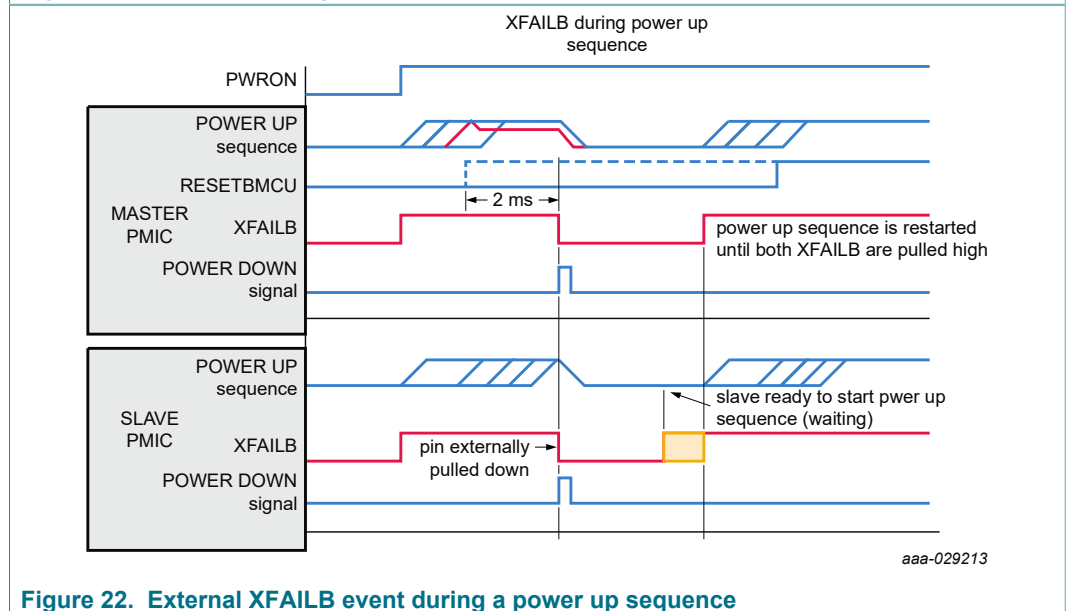

Figure 22. External XFAILB event during a power up sequence

14.9.14 SDA and SCL (I²C bus)

Communication with the PF7100 is done through I²C and it supports high-speed operation mode with up to 3.4 MHz operation. SDA and SCL are pulled up to VDDIO with 1.5 kΩ resistor if 3.4 MHz I²C speed is required.

7-channel power management integrated circuit for high performance applications

The PF7100 is designed to operate as a slave device during I²C communication. The default I²C device address is set by the OTP_I2C_ADD[2:0].

Table 35. I²C address configuration

OTP_I2C_ADD[2:0]	Device address
000	0x08
001	0x09
010	0x0A
011	0x0B
100	0x0C
101	0x0D
110	0x0E
111	0x0F

See http://www.nxp.com/documents/user_manual/UM10204.pdf for detailed information on the digital I²C communication protocol implementation.

During an I²C transaction, the communication latches after the 8th bit sent. If the data sent is not a multiple of 8 bit, any word with less than 8 bits are ignored. If only 7 bits are sent, no data is written and the logic does not provide an ACK bit to the MCU.

From an IC level, a wrong I²C command can create a system level safety issue. For example, though the MCU may have intended to set a given regulator's output to 1.0 V, it may be erroneously registered as 1.1 V due to noise in the bus.

To prevent a wrong I²C configuration, various protective mechanisms are implemented.

14.9.14.1 I²C CRC verification

When this feature is enabled, a selectable CRC verification is performed on each I²C transaction.

- When OTP_I2C_CRC_EN = 0, the CRC verification mechanism is disabled.
- When OTP_I2C_CRC_EN = 1, the CRC verification mechanism is enabled.

After each I²C transaction, the device calculates the corresponding CRC byte to ensure that the configuration command has not been corrupted.

When a CRC fault is detected, the PF7100 ignores the erroneous configuration command and triggers a CRC_I interrupt asserting the INTB pin, provided the interrupt is not masked.

The PF7100 implements a CRC-8-SAE, per the SAE J1850 specification.

- Polynomial = 0x11D
- Initial value = 0xFF

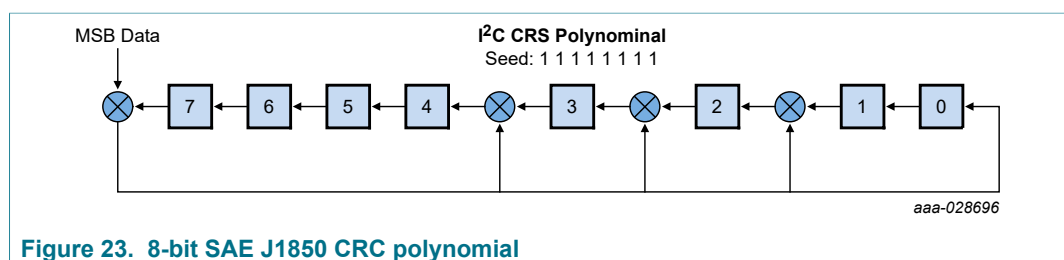

Figure 23. 8-bit SAE J1850 CRC polynomial

14.9.14.2 I²C secure write

A secure write mechanism is implemented for specific registers critical to the functional safety of the device.

- When OTP_I2C_SECURE_EN = 0, the secure write is disabled.
- When OTP_I2C_SECURE_EN = 1, the secure write is enabled.

When the secure write is enabled, a specific sequence must be followed in order to grant writing access on the corresponding secure register.

Secure write sequence is as follows:

- MCU sends command to modify the secure registers
- PMIC generates a random code in the RANDOM_GEN register
- MCU reads the random code from the RANDOM_GEN register and writes it back on the RANDOM_CHK register

The PMIC compares the RANDOM_CHK against the RANDOM_GEN register:

- If RANDOM_CHK [7:0] = RANDOM_GEN[7:0], the device applies the configuration on the corresponding secure register, and self-clears both the RANDOM_GEN and RANDOM_CHK registers.
- If RANDOM_CHK[7:0] different from RANDOM_GEN[7:0], the device ignores the configuration command and self-clears both the RANDOM_GEN and RANDOM_CHK registers.

In the event the MCU sends any other command instead of providing a value for the RANDOM_CHK register, the state machine cancels the ongoing secure write transaction and performs the new I²C command.

In the event the MCU does not provide a value for the RANDOM_CHK register, the I²C transaction times out 10 ms after the RANDOM_GEN code is generated, and device is ready for a new transaction.

Table 36. Secure bits

Register	Bit	Description
ABIST OV1	AB_SW1_OV	Writing a 1 to this flag to clear the ABIST fault notification
ABIST OV1	AB_SW2_OV	Writing a 1 to this flag to clear the ABIST fault notification
ABIST OV1	AB_SW3_OV	Writing a 1 to this flag to clear the ABIST fault notification
ABIST OV1	AB_SW4_OV	Writing a 1 to this flag to clear the ABIST fault notification
ABIST OV1	AB_SW5_OV	Writing a 1 to this flag to clear the ABIST fault notification
ABIST OV2	AB_LDO1_OV	Writing a 1 to this flag to clear the ABIST fault notification
ABIST OV2	AB_LDO2_OV	Writing a 1 to this flag to clear the ABIST fault notification
ABIST UV1	AB_SW1_UV	Writing a 1 to this flag to clear the ABIST fault notification
ABIST UV1	AB_SW2_UV	Writing a 1 to this flag to clear the ABIST fault notification

7-channel power management integrated circuit for high performance applications

Register	Bit	Description
ABIST UV1	AB_SW3_UV	Writing a 1 to this flag to clear the ABIST fault notification
ABIST UV1	AB_SW4_UV	Writing a 1 to this flag to clear the ABIST fault notification
ABIST UV1	AB_SW5_UV	Writing a 1 to this flag to clear the ABIST fault notification
ABIST UV2	AB_LDO1_UV	Writing a 1 to this flag to clear the ABIST fault notification
ABIST UV2	AB_LDO2_UV	Writing a 1 to this flag to clear the ABIST fault notification
ABIST RUN	AB_RUN	Writing a 1 starts an ABIST on demand
FSOB FLAGS	FSOB_ASS_NOK	Writing a 1 to this flag to clear the FSOB flag
FSOB FLAGS	FSOB_SFAULT_NOK	Writing a 1 to this flag to clear the FSOB flag
FSOB FLAGS	FSOB_WDI_NOK	Writing a 1 to this flag to clear the FSOB flag
FSOB FLAGS	FSOB_WDC_NOK	Writing a 1 to this flag to clear the FSOB flag
FSOB FLAGS	FSOB_HFAULT_NOK	Writing a 1 to this flag to clear the FSOB flag
CTRL1	TMP_MON_EN	Writing a 0 disables the thermal monitor, preventing the thermal interrupts and thermal shutdown event from being detected
CTRL1	WDI_MODE	Writing a 0 sets the WDI event to soft WD reset Writing a 1 sets the WDI event to hard WD reset
CTRL1	VIN_OVLO_EN	Writing a 0 disables the VIN overvoltage lockout monitor completely
CTRL1	VIN_OVLO_SDWN	Writing a 0 disables a shutdown event upon a VIN overvoltage condition (only interrupts are provided)
CTRL1	WD_EN	Writing a 0 disables the watchdog counter block
CTRL1	WD_STBY_EN	Writing a 0 disables the watchdog counter during the standby mode
CTRL1	WDI_STBY_ACTIVE	Writing a 0 disables the monitoring of WDI input during standby mode
CTRL1	I2C_SECURE_EN	Writing a 0 disables the I ² C secure write mode
VMONEN1	SW1VMON_EN	Writing a 0 disables the OV/UV monitor for SW1
VMONEN1	SW2VMON_EN	Writing a 0 disables the OV/UV monitor for SW2
VMONEN1	SW3VMON_EN	Writing a 0 disables the OV/UV monitor for SW3
VMONEN1	SW4VMON_EN	Writing a 0 disables the OV/UV monitor for SW4
VMONEN1	SW5VMON_EN	Writing a 0 disables the OV/UV monitor for SW5
VMONEN2	LDO1VMON_EN	Writing a 0 disables the OV/UV monitor for LDO1
VMONEN2	LDO2VMON_EN	Writing a 0 disables the OV/UV monitor for LDO2

15 Functional blocks

15.1 Analog core and internal voltage references

All regulators use the main band gap as the reference for the output voltage generations. The main band gap is also used as reference for the internal analog core and digital core supplies. The performance of the regulators is directly dependent on the performance of the band gap.

7-channel power management integrated circuit for high performance applications

No external DC loading is allowed on V1P5A and V1P5D. V1P5D is kept powered as long as there is a valid supply and it may be used as a reference voltage for the VDDOTP and TBBEN pins during system power on.

A second band gap is provided as the reference for all the monitoring circuits. This architecture allows the PF7100 to provide a reliable way to detect not only single point, but also latent faults, in order to meet the metrics required by an ASIL B level application.

Table 37. Internal supplies electrical characteristics

Symbol	Parameter	Min	Typ	Max	Unit
V _{1P5D}	V1P5D output voltage	1.50	1.60	1.65	V
C _{1P5D}	V1P5D output capacitor	—	1.0	—	μF
V _{1P5A}	V1P5A output voltage	1.50	1.60	1.65	V
C _{1P5A}	V1P5A output capacitor	—	1.0	—	μF

15.2 VSNVS LDOs

VSNVS1 and VSNVS2 are 10 mA LDOs provided to power the RTC domain in the processor. In systems using the i.MX8 processors, they power the VDD_SNVS_IN domain of the MCU.

VSNVS1 and VSNVS2 remain disabled until VIN > UVDET as well as the VSNVS1 and VSNVS2 get loaded with the OTP fuse configuration.

When VIN is applied, VSNVS1 and VSNVS2 are initially disabled and they are only enabled to their regulation point after OTP fuses are loaded.

- When VIN is rising and VIN > UVDET, VSNVS1 and VSNVS2 are powered by VIN. If the configured output voltage is higher than the input source, VSNVS1 operates in dropout mode to track the input voltage.

The following table shows the expected operation of the VSNVS1 block for different voltage settings and different input voltage conditions. VSNVS2 block always works at regulation mode.

Table 38. VSNVS1 operation description

OTP_VSNVS1VOLT[1:0]	VSNVS1 output voltage (V)	VIN	Expected VSNVS output
00	Disabled	Do not care	VSNVS1 is disabled on OTP
01	1.8	> UVDET rising	Regulate to 1.8 V from VIN
10	3.0	> UVDET rising	Regulate to 3.0 V from VIN or track VIN in dropout mode
11	3.3	> UVDET rising	Regulate to 3.3 V from VIN or track VIN in dropout mode

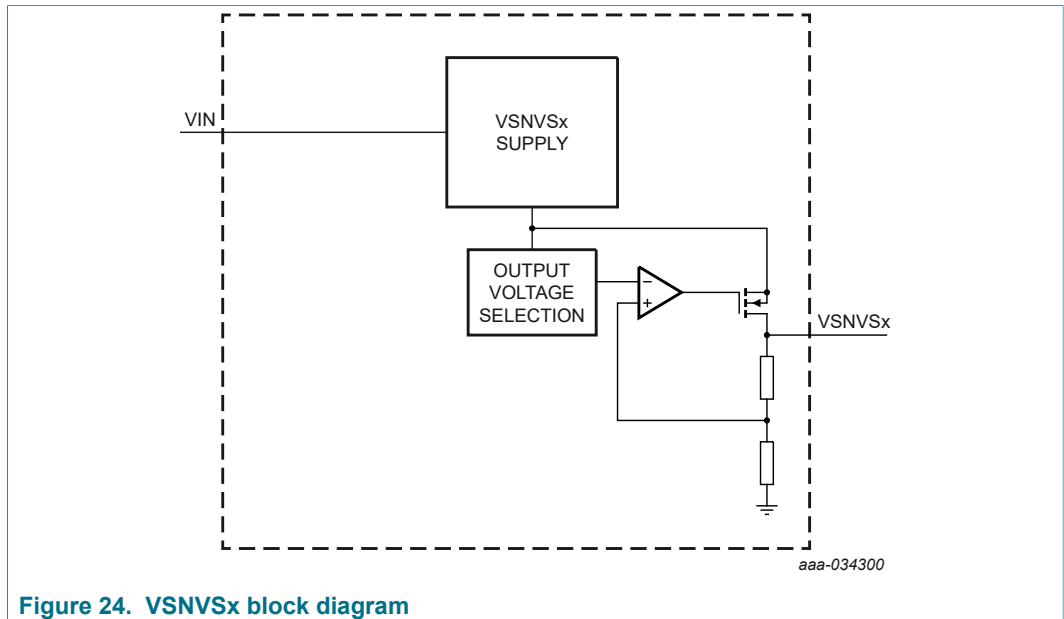

Figure 24. VSNVSx block diagram

The VSNVS1 and VSNVS2 output keep regulation through all states, including the system-on, OFF modes, power down sequence, watchdog reset, fail-safe transition, and fail-safe state as long as there is a valid input (VIN), and the outputs have been configured by the OTP_VSNVSxVOLT[1:0] registers.

Table 39. VSNVS1 output voltage configuration

OTP_VSNVS1VOLT[1:0]	VSNVS1VOLT[1:0]	VSNVS1 output voltage (V)
00	00	Off
01	01	1.8
10	10	3.0
11	11	3.3

Table 40. VSNVS2 output voltage configuration

OTP_VSNVS2VOLT[1:0]	VSNVS2VOLT[1:0]	VSNVS2 output voltage (V)
00	00	Off
01	01	0.8
10	10	0.9
11	11	1.8

For system debugging purposes, the VSNVS1 and VSNVS2 output may be changed during the system-on states by changing the VSNVSxVOLT[1:0] bits in the functional I²C registers.

Table 41. VSNVSx electrical characteristics

All parameters are specified at $T_A = -40\text{ °C}$ to 125 °C for AEC-Q100 grade 1 device, unless otherwise noted. All parameters are specified at $T_A = -40\text{ °C}$ to 105 °C for AEC-Q100 grade 2 device, unless otherwise noted. Typical values are characterized at $V_{IN} = 5.0\text{ V}$, and $T_A = 25\text{ °C}$, unless otherwise noted.

Symbol	Parameter	Min	Typ	Max	Unit
V_{IN_SNVSx}	Operating voltage range from VIN	2.5	—	5.5	V

Symbol	Parameter	Min	Typ	Max	Unit
I_{SNVSx}	VSNVSx load current range	0	—	10	mA
V_{SNVSx_ACC}	VSNVSx output voltage accuracy in LDO mode	-5.0	—	5.0	%
V_{SNVS1_RDSO}	VSNVS1 LDO on resistance VSNVS1VOLT[1:0] = 10 or 11	—	—	20	Ω
V_{SNVSx_IQ}	VSNVSx quiescent current in LDO mode	—	5.0	—	μ A
V_{SNVS1_HDR}	VSNVS1 LDO headroom voltage Minimum voltage above setting VSNVS1VOLT[1:0] = 10 or 11 to guarantee regulation with 5 % tolerance	200	—	—	mV
V_{SNVS1_HDR}	VSNVS1 LDO headroom voltage Minimum voltage above setting VSNVS1VOLT[1:0] = 01 to guarantee regulation with 5 % tolerance	500	—	—	mV
V_{SNVSx_OS}	VSNVSx startup overshoot	—	—	200	mV
V_{SNVSx_TRANS}	VSNVSx load transient	-100	—	100	mV
V_{SNVSx_ILIM}	VSNVSx current limit	20	—	70	mA
V_{SNVSx_TON}	VSNVSx turn on time Block enabled to VSNVSx at 90 % of final value	—	—	1.35	ms

15.3 Type 1 buck regulators (SW1 to SW4)

The PF7100 features four low-voltage regulators with input supply range from 2.5 V to 5.5 V and output voltage range from 0.4 V to 1.8 V in 6.25 mV steps. Each voltage regulator is capable to supply 2.5 A and features a programmable soft-start and DVS ramp for system power optimization.

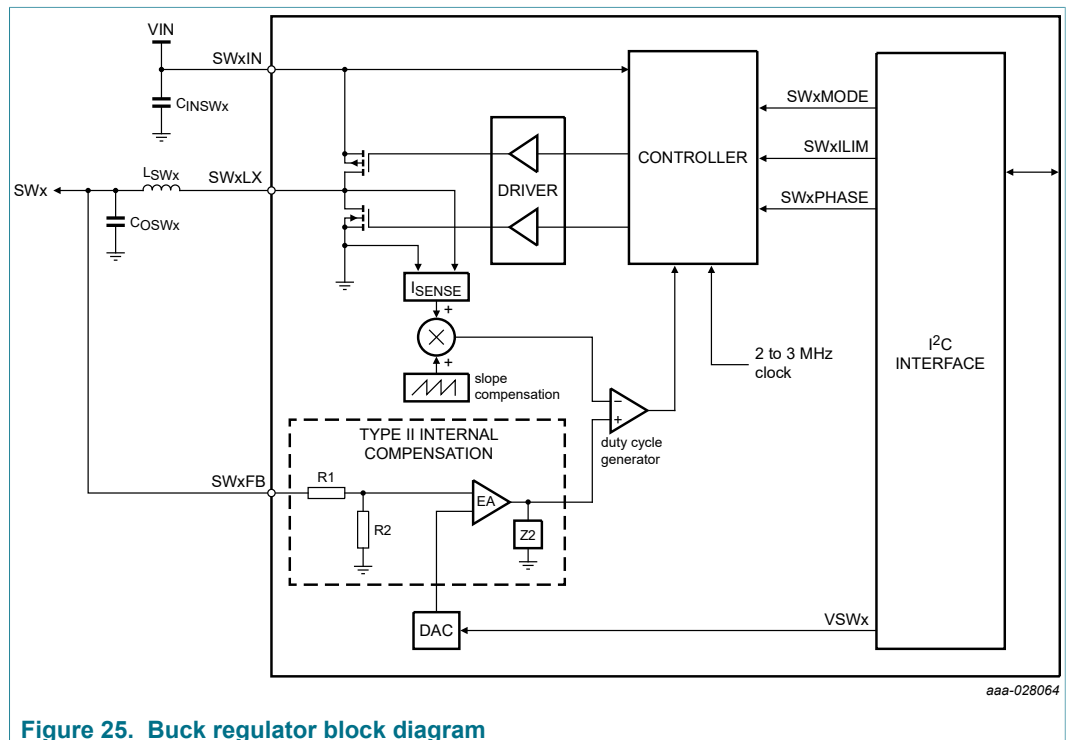

Figure 25. Buck regulator block diagram

7-channel power management integrated circuit for high performance applications

The OTP_SWxDVS_RAMP bit sets the default step/time ratio for the power up ramp during the power up/down sequence as well as the DVS slope during the system-on.

The power down ramp and DVS rate during the system on of SW1 to SW4 can be modified during the system-on states by changing the SWxDVS_RAMP bit on the I²C register map.

The DVS ramp rate is based on the internal clock configuration as shown in the following table:

Table 42. SW1 to SW4 ramp rates

All ramp rates are typical values. Clock frequency tolerance = ± 5 %.

CLK_FREQ[3:0]	Clock frequency (MHz)	Regulators frequency (MHz)	SWxDVS_RAMP = 00 DVS_Up (mV/μs) / DVS_Down (mV/μs)	SWxDVS_RAMP = 01 DVS_Up (mV/μs) / DVS_Down (mV/μs)	SWxDVS_RAMP = 10 DVS_Up (mV/μs) / DVS_Down (mV/μs)	SWxDVS_RAMP = 11 DVS_Up (mV/μs) / DVS_Down (mV/μs)
0000	20	2.500	7.81 / 5.21	15.63 / 10.42	3.91 / 2.60	1.95 / 1.30
0001	21	2.625	8.20 / 5.47	16.41 / 10.94	4.10 / 2.73	2.05 / 1.37
0010	22	2.750	8.59 / 5.73	17.19 / 11.46	4.30 / 2.86	2.15 / 1.43
0011	23	2.875	8.98 / 5.99	17.97 / 11.98	4.49 / 2.99	2.25 / 1.50
0100	24	3.000	9.38 / 6.25	18.75 / 12.50	4.69 / 3.13	2.34 / 1.56
1001	16	2.000	6.25 / 4.17	12.50 / 8.33	3.13 / 2.08	1.56 / 1.04
1010	17	2.125	6.64 / 4.43	13.28 / 8.85	3.32 / 2.21	1.66 / 1.11
1011	18	2.250	7.03 / 4.69	14.06 / 9.38	3.52 / 2.34	1.76 / 1.17
1100	19	2.375	7.42 / 4.95	14.84 / 9.90	3.71 / 2.47	1.86 / 1.24

Buck regulators SW1 to SW4 use 8 bits to set the output voltage.

- The VSWx_RUN[7:0] set the output voltage during the run mode.
- The VSWx_STBY[7:0] set the output voltage during the standby mode.

The default output voltage configuration for the run and the standby modes is loaded from the OTP_VSWx[7:0] registers upon power up.

Table 43. SW1 to SW4 output voltage configuration

Set point	VSWx_RUN[7:0] VSWx_STBY[7:0]	V _{SWx} FB (V)
0	00000000	0.40000
1	00000001	0.40625
2	00000010	0.41250
3	00000011	0.41875
.	.	.
.	.	.
175	10101111	1.49375
176	10110000	1.50000
177	10110001	1.80000
178 to 255	10110010 to 11111111	Reserved

DVS operation is available for all voltage settings between 0.4 V to 1.5 V. However, the SWx regulator is not intended to perform DVS transitions to or from the 1.8 V configuration. In the event a voltage change is requested between any of the low voltage

7-channel power management integrated circuit for high performance applications

settings and 1.8 V, the switching regulator is automatically disabled first and then re-enabled at the selected voltage level to avoid an uncontrolled transition to the new voltage setting.

Each regulator is provided with 2 bits to set its mode of operation.

- The SWx_RUN_MODE[1:0] bits allow the user to change the mode of operation of the SWx regulators during the run state. If the regulator was programmed as part of the power up sequence, the SWx_RUN_MODE[1:0] bits are loaded with 0b11 (autoskip) by default. Otherwise it is loaded with 0b11 (disabled).
- The SWx_STBY_MODE[1:0] bits allow the user to change the mode of operation of the SWx regulators during the standby state. If the regulator was programmed as part of the power up sequence, the SWx_STBY_MODE[1:0] bits are loaded with 0b11 (autoskip) by default. Otherwise, it is loaded with 0b11 (disabled).

Table 44. SW regulator mode configuration

SWx_MODE[1:0]	Mode of operation
00	OFF
01	PWM mode
10	PFM mode
11	Auto skip mode

The SWx_MODE_I interrupt asserts the INTB pin when any of the Type 1 regulators have changed the mode of operation, provided the corresponding interrupt is not masked.

To avoid potential detection of an OV/UV fault during SWx ramp up, it is recommended to power up the regulator in PWM or auto skip mode.

SW1 to SW4 regulators use 2 bits SWxILIM[1:0], to program the current limit detection.

Table 45. SWx current limit selection

SWxILIM[1:0]	Typical current limit
00	2.1 A
01	2.6 A
10	3.0 A
11	4.5 A

The current limit specification is given with respect to the inductor peak current. To calculate the DC current at which the buck regulator enters into current limitation, it is necessary to calculate the inductor ripple current. An ideal approximation is enough to obtain the ripple current as follows:

$$\Delta iL = VOUT \times (1 - VOUT/VIN)/(L \times FSW)$$

L is the inductance value and FSW is the selected switching frequency.

The DC current limit is then calculated by:

$$DC\ ILIM = ILIM - (\Delta iL / 2)$$

In order to account for component tolerances, use the minimum inductor value per the inductor specification.

During single phase operation, all buck regulators use 3 bits (SWxPHASE[2:0]) to control the phase shift of the switching frequency. The default switching phase is loaded from

the OTP_SWxPHASE[2:0] registers at power up. The SWxPHASE[2:0] can be modified during the system-on states.

Table 46. SWx phase configuration

SWx_PHASE[2:0]	Phase shift (degrees)
000	45
001	90
010	135
011	180
100	225
101	270
110	315
111	0 (default)

Each one of the buck regulator provides 2 OTP bits to configure the value of the inductor used in the corresponding block. The OTP_SWx_LSELECT[1:0] allow to choose the inductor as shown in the following table.

Table 47. SWx inductor selection bits

OTP_SWx_LSELECT[1:0]	Inductor value
00	1.0 μ H
01	0.47 μ H
10	1.5 μ H
11	Reserved

15.3.1 SW3 VTT operation

SW3 features a selectable VTT mode to create VTT termination for DDR memories.

When SW3_VTTEN = 1, the VTT mode is enabled. In this mode, SW3 reference voltage is internally connected to SW4FB output through a divider by 2.

During the VTT mode, the DVS operation on SW3 is disabled and SW3 output is given by $V_{SW4FB} / 2$. In this mode, the minimum output voltage configuration for SW4 should be 800 mV to ensure that the SW3 is still within the regulation range at its output.

During the power-up sequence, the SW3 (VTT) may be turned on in the same or at a slot later than SW4, as required by the system. When SW3 and SW4 are enabled in the same slot, SW3 always tracks the $V_{SW4}/2$. When SW3 is enabled after SW4, it ramps up gradually to a predefined voltage and once this voltage is reached, it starts tracking $V_{SW4}/2$. The user may adjust the value at which the SW3 should start tracking the voltage on the SW4 regulator by setting the OTP_VSW3 register accordingly.

During normal operation, if the SW4 is disabled via the I²C command, SW3 tracks the output of SW4 and both regulators are discharged together and pulled down internally. When SW4 is enabled back via the I²C commands, the SW3 output ramps up to the corresponding voltage while SW3 is always $V_{SW4}/2$.

When only SW3 is disabled, the PMIC uses the OTP_VTT_PDOWN bit to program whether the SW3 regulator is disabled with the output in high impedance or discharged internally.

- When OTP_VTT_PDOWN = 0, the output is disabled in high impedance mode.

7-channel power management integrated circuit for high performance applications

- When `OTP_VTT_PDOWN = 1`, the output is disabled with the internal pull down enabled.

When SW3 is requested to enable back again, the SW3 ramps up to the voltage set on the `VSW3_RUN` or `VSW3_STBY` registers. Once it reaches the final DVS value, it changes its reference to start tracking SW4 output again. Note that `VSW3_RUN(STBY)` must be set to `VSW4_RUN(STBY)/2` or the closest code by the MCU to ensure proper operation.

When operating in VTT mode, the minimum output voltage configuration for SW4 should be 800 mV to ensure that the SW3 is still within the regulation range at its output.

15.3.2 Multiphase operation

Regulators SW1, SW2, SW3, and SW4 can be configured in dual, triple, and quad phase mode. In these modes, SW1 registers control the output voltage and other configurations. Likewise, SW1FB pin becomes the main feedback node for the resulting voltage rail, however the FB pins of SWx in multiphase should be connected together.

The `OTP_SW1CONFIG[1:0]` bits are used to select the dual, triple, or quad phase configuration.

Table 48. OTP_SW1CONFIG register description

OTP_SW1CONFIG[1:0]	Description
00	SW1 and SW2 operate in single phase mode
01	SW1/SW2 operate in dual phase mode
10	SW1/SW2/SW3/SW4 operate in quad phase mode
11	SW1/SW2/SW3 operate in triple phase mode

Regulators SW3 and SW4 can be configured in dual phase mode. In this mode, SW4 registers control the output voltage and other configurations. Likewise, SW4FB pin becomes the main feedback node for the resulting voltage rail, however the two FB pins should be connected together.

The `OTP_SW4CONFIG[1:0]` bits are used to select the dual phase operation of SW3/SW4.

Table 49. OTP_SW4CONFIG register description

OTP_SW4CONFIG[1:0]	Description
00	SW3 and SW4 operate in single phase mode
01	SW3/SW4 operate in dual phase mode
10	Reserved
11	Reserved

Configuring regulators SW1 through SW3 in triple phase operation or SW1 through SW4 in quad phase operation overrides the configuration of the `OTP_SW4CONFIG[1:0]` bits, SW4 is forced in single phase.

In multiphase operation, the `SWxPHASE[1:0]` bit is used to select the SWx phase independently from each other.

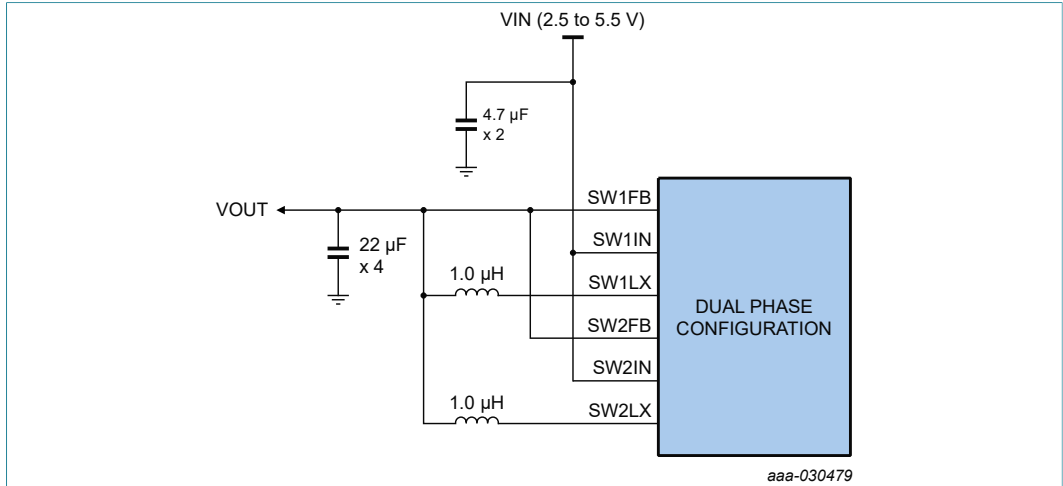

Figure 26. Dual phase configuration

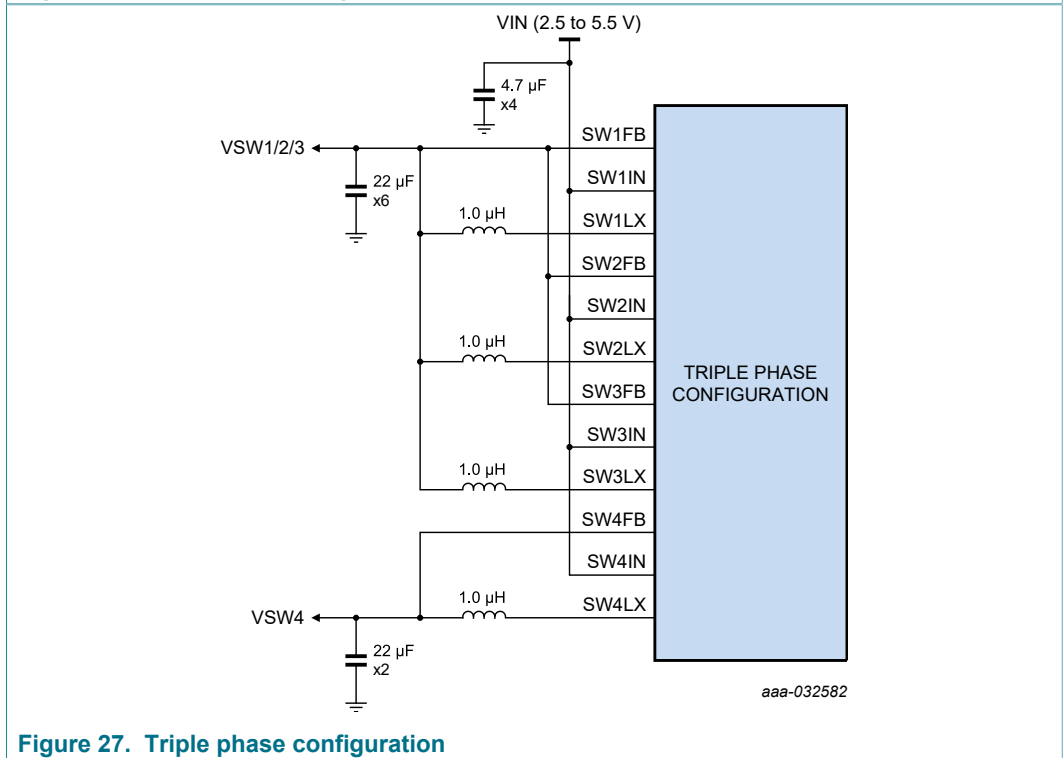

Figure 27. Triple phase configuration

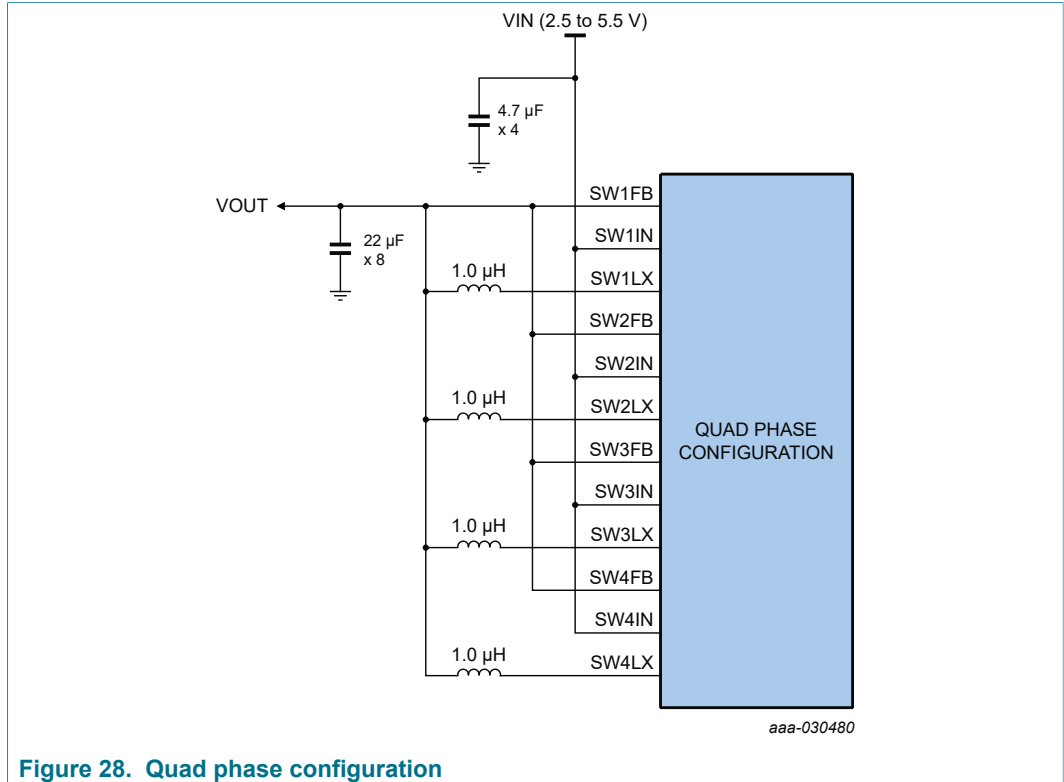

Figure 28. Quad phase configuration

15.3.3 Electrical characteristics

Table 50. Type 1 buck regulator electrical characteristics

All parameters are specified at $T_A = -40\text{ }^\circ\text{C}$ to $125\text{ }^\circ\text{C}$ for AEC-Q100 grade 1 device, all parameters are specified at $T_A = -40\text{ }^\circ\text{C}$ to $105\text{ }^\circ\text{C}$ for AEC-Q100 grade 2 device, $V_{IN} = V_{SWxIN} = UVDET$ to 5.5 V , $V_{SWxFB} = 1.0\text{ V}$, $I_{SWx} = 500\text{ mA}$, typical external component values, $f_{SW} = 2.25\text{ MHz}$, unless otherwise noted. Typical values are characterized at $V_{IN} = V_{SWxIN} = 5.0\text{ V}$, $V_{SWxFB} = 1.0\text{ V}$, $I_{SWx} = 500\text{ mA}$, and $T_A = 25\text{ }^\circ\text{C}$, unless otherwise noted.

Symbol	Parameter [1] [2]	Min	Typ	Max	Unit
V_{SWxIN} [3]	Operating functional input voltage	UVDET	—	5.5	V
V_{SWxACC}	Output voltage accuracy PWM mode $0.4\text{ V} \leq V_{SWxFB} < 0.8\text{ V}$ $0 \leq I_{SWx} \leq 2.5\text{ A}$	-10	—	10	mV
V_{SWxACC}	Output voltage accuracy PWM mode $0.8\text{ V} \leq V_{SWxFB} \leq 1.0\text{ V}$ $0 \leq I_{SWx} \leq 2.5\text{ A}$	-1.5	—	1.5	%
V_{SWxACC}	Output voltage accuracy PWM mode $1.0\text{ V} < V_{SWxFB} \leq 1.5\text{ V}$ $0 \leq I_{SWx} \leq 2.5\text{ A}$	-1.5	—	1.5	%
V_{SWxACC}	Output voltage accuracy PWM mode $V_{SWxFB} = 1.8\text{ V}$ $0 \leq I_{SWx} \leq 2.5\text{ A}$	-1.5	—	1.5	%

7-channel power management integrated circuit for high performance applications

Symbol	Parameter [1] [2]	Min	Typ	Max	Unit
V _{SWxACCPFM}	Output voltage accuracy PFM mode 0.4 V ≤ V _{SWxFB} ≤ 1.5 V 0 ≤ I _{SWx} ≤ 100 mA	-36	—	36	mV
V _{SWxACCPFM}	Output voltage accuracy PFM mode V _{SWxFB} = 1.8 V 0 ≤ I _{SWx} ≤ 100 mA	-57	—	57	mV
t _{PFMtoPWM}	PFM to PWM transition time	30	—	—	μs
I _{SWx} [4]	Max load current in single phase	2500	—	—	mA
I _{SWx_DP} [4]	Max load current in dual phase	5000	—	—	mA
I _{SWx_TP}	Max load current in triple phase	7500	—	—	mA
I _{SWx_QP}	Max load current in quad phase	10000	—	—	mA
I _{SWxLIM}	Current limiter - inductor peak current detection SWxLIM[1:0] = 00	1.6	2.1	2.5	A
I _{SWxLIM}	Current limiter - inductor peak current detection SWxLIM[1:0] = 01	2.0	2.6	3.1	A
I _{SWxLIM}	Current limiter - inductor peak current detection SWxLIM[1:0] = 10	2.4	3.0	3.7	A
I _{SWxLIM}	Current limiter - inductor peak current detection SWxLIM[1:0] = 11	3.6	4.5	5.45	A
I _{SWxNLIM}	Negative current limit in single phase mode	0.6	1.0	1.4	A
I _{SWxxLIM_DP}	Current limit in dual phase operation SWxLIM = 00 (master)	3.2	4.2	5.0	A
I _{SWxxLIM_DP}	Current limit in dual phase operation SWxLIM = 01 (master)	4.0	5.2	6.2	A
I _{SWxxLIM_DP}	Current limit in dual phase operation SWxLIM = 10 (master)	4.8	6.0	7.4	A
I _{SWxxLIM_DP}	Current limit in dual phase operation SWxLIM = 11 (master)	7.2	9.0	10.9	A
I _{SWxxLIM_TP}	Current limit in triple phase operation SWxLIM = 00 (master)	4.8	6.3	7.5	A
I _{SWxxLIM_TP}	Current limit in triple phase operation SWxLIM = 01 (master)	6.0	7.8	9.3	A
I _{SWxxLIM_TP}	Current limit in triple phase operation SWxLIM = 10 (master)	7.2	9.0	11.1	A
I _{SWxxLIM_TP}	Current limit in triple phase operation SWxLIM = 11 (master)	10.8	13.5	16.35	A
I _{SWxxLIM_QP}	Current limit in quad phase operation SW1LIM = 00 (master)	7.2	8.4	10	A
I _{SWxxLIM_QP}	Current limit in quad phase operation SW1LIM = 01 (master)	8.0	10.4	12.4	A
I _{SWxxLIM_QP}	Current limit in quad phase operation SW1LIM = 10 (master)	9.6	12.0	14.8	A
I _{SWxxLIM_QP}	Current limit in quad phase operation SW1LIM = 11 (master)	14.4	18.0	21.8	A

7-channel power management integrated circuit for high performance applications

Symbol	Parameter [1] [2]	Min	Typ	Max	Unit
V_{SWxOSH}	Startup overshoot SWxDVS RAMP = 6.25 mV/ μ s VSWxIN = 5.5 V, VSWxFB = 1.0 V	-25	25	50	mV
t_{ONSWx}	Turn on time From enable to 90 % of end value SWxDVS RAMP = 0 (6.25 mV/ μ s) VSWxIN = 5.5 V, VSWxFB = 1.0 V	—	160	—	μ s
$t_{ONSWxMAX}$	Maximum turn on time From enable to 90 % of end value SWxDVS RAMP = 11 (1.56 mV/ μ s, 2 MHz) VSWxIN = 5.5 V, VSWxFB = 1.5 V	—	—	895	μ s
t_{ONSWx_MIN}	Minimum turn on time From enable to 90 % of end value SWxDVS RAMP = 01 (18.75 mV/ μ s, 3 MHz) VSWxIN = 5.5 V, VSWxFB = 0.4 V	49.2	—	—	μ s
η_{SWx}	Efficiency (PFM mode, 1.0 V, 1.0 mA)	—	80	—	%
η_{SWx}	Efficiency (PFM mode, 1.0 V, 50 mA)	—	81	—	%
η_{SWx}	Efficiency (PFM Mode, 1.0 V, 100 mA)	—	82	—	%
η_{SWx}	Efficiency (PWM mode, 1.0 V, 500 mA)	—	83	—	%
η_{SWx}	Efficiency (PWM mode, 1.0 V, 1000 mA)	—	82	—	%
η_{SWx}	Efficiency (PWM mode, 1.0 V, 2000 mA)	—	79	—	%
F_{SWx}	PWM switching frequency range Frequency set by CLK_FREQ[3:0]	1.9	2.5	3.15	MHz
$T_{OFFminSWx}$	Minimum off time	—	27	—	ns
T_{DBSWx}	Deadband time	—	3.0	—	ns
T_{slew}	Slewing time (10 % to 90 %)	—	—	5.0	ns
D_{VSWx}	Output ripple in PWM mode	—	—	1.0	%
$V_{SWxLOTR}$	Transient load regulation (overshoot/undershoot) at $0.8\text{ V} < V_{SWxFB} \leq 1.2\text{ V}$ ILoad = 200 mA to 1.0 A, di/dt = 2.0 A/ μ s (single phase) ILoad = 400 mA to 2.0 A, di/dt = 4.0 A/ μ s (dual phase) ILoad = 600 mA to 3.0 A, di/dt = 6.0 A/ μ s (triple phase) ILoad = 800 mA to 4.0 A, di/dt = 8.0 A/ μ s (quad phase) Output capacitance = 44 μ F per phase	-25	—	+25	mV
$V_{SWxLOTR}$	Transient load regulation (overshoot/undershoot) at $1.25 < V_{SWxFB} < 1.8\text{ V}$ ILoad = 200 mA to 1.0 A, di/dt = 2.0 A/ μ s (single phase) ILoad = 400 mA to 2.0 A, di/dt = 4.0 A/ μ s (dual phase) ILoad = 600 mA to 3.0 A, di/dt = 6.0 A/ μ s (triple phase) ILoad = 800 mA to 4.0 A, di/dt = 8.0 A/ μ s (quad phase) Output capacitance = 44 μ F per phase	-3.0	—	+3.0	%

7-channel power management integrated circuit for high performance applications

Symbol	Parameter [1] [2]	Min	Typ	Max	Unit
I _{RCS}	DCM (skip mode) reverse current sense threshold Current flowing from PGND to SWxLX	-200	—	200	mA
I _{SWxQ}	Quiescent current PFM mode	—	14	—	μA
I _{SWxQ}	Quiescent current Auto skip mode	—	160	250	μA
I _{SWxQ_DP}	Quiescent current in dual phase PWM mode	—	200	320	μA
I _{SWxQ_QP}	Quiescent current in quad phase PWM mode	—	240	480	μA
R _{ONSWxHS}	SWx high-side P-MOSFET R _{DS(on)}	—	—	135 [5]	mΩ
R _{ONSWxLS}	SWx low-side N-MOSFET R _{DS(on)}	—	—	80 [5]	mΩ
R _{SWxDIS}	Discharge resistance Regulator disabled and ramp down completed	20	70	120	Ω

- [1] For VSWx configurations greater than 1.35 V, full parametric operation is guaranteed for 2.7 V < SWxVIN < 5.5 V. Below 2.7 V, the SWx regulators are fully functional with degraded operation due to headroom limitation.
- [2] For VSWx = 1.8 V, output capacitance should be kept at or below the maximum recommended value. Likewise, it is recommended to use a slow turn-on/off ramp rate to ensure that the output is discharged completely when it is disabled.
- [3] VSWxIN must be connected to VIN to ensure proper device operation.
- [4] The Type 1 buck regulator in single or dual phase configuration is capable of providing output current above the nominal max current specification as long as it does not reach the current limitation. However, if operating above the nominal maximum current, overall thermal considerations must be taken to prevent reaching PMIC thermal shutdown during high ambient temperature conditions.
- [5] Max R_{DS(on)} does not include bond wire resistance. Consider ± 50 % tolerance to account for bond wire and pin loss.

Table 51. Recommended external components

Symbol	Parameter	Min	Typ	Max	Unit
L	Output inductor Maximum inductor DC resistance 50 mΩ [1] Minimum saturation current at full load: 3.0 A	0.47	1.0	1.5	μH
C _{out}	Output capacitor Use 2 x 22 μF, 6.3 V X7T ceramic capacitor to reduce output capacitance ESR.	—	44	—	μF
C _{in}	Input capacitor 4.7 μF, 10 V X7R ceramic capacitor	—	4.7	—	μF

- [1] Keep inductor DCR as low as possible to improve regulator efficiency.

15.4 Type 2 buck regulator (SW5)

The PF7100 also features one single phase low-voltage buck regulator (SW5) with an input voltage range between 2.5 V and 5.5 V and an output voltage range from 1.0 V to 4.1 V.

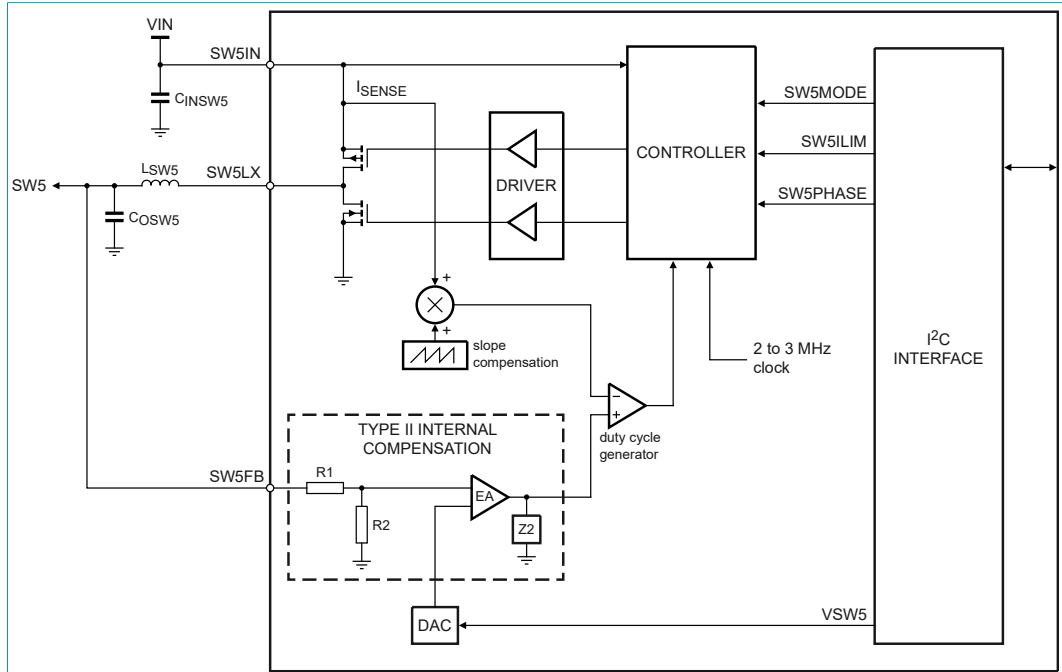

Figure 29. Type 2 buck regulator block diagram

Buck regulator SW5 uses 5 bits to set the output voltage. The VSW5[4:0] sets the output voltage during the run and the standby mode.

The SW5 is designed to have a fixed voltage throughout all the system operation. In the event a system requires this regulator to change its output voltage during the system-on states, when the SW5 is commanded to change its voltage via the I²C command, the output is discharged first and then enabled back to the new voltage level as stated in the VSW5[4:0] bits.

The default output voltage configuration for the run and the standby modes is loaded from the OTP_VSW5[4:0] registers upon power up.

Table 52. SW5 output voltage configuration

Set point	VSW5[4:0]	V _{SW5FB} (V)
0	0 0000	1.00
1	0 0001	1.10
2	0 0010	1.20
3	0 0011	1.25
4	0 0100	1.30
5	0 0101	1.35
6	0 0110	1.50
7	0 0111	1.60
8	0 1000	1.80
9	0 1001	1.85
10	0 1010	2.00
11	0 1011	2.10
12	0 1100	2.15

7-channel power management integrated circuit for high performance applications

Set point	VSW5[4:0]	V _{SW5FB} (V)
13	0 1101	2.25
14	0 1110	2.30
15	0 1111	2.40
16	1 0000	2.50
17	1 0001	2.80
18	1 0010	3.15
19	1 0011	3.20
20	1 0100	3.25
21	1 0101	3.30
22	1 0110	3.35
23	1 0111	3.40
24	1 1000	3.50
25	1 1001	3.80
26	1 1010	4.00
27	1 1011	4.10
28	1 1100	4.10
29	1 1101	4.10
30	1 1110	4.10
31	1 1111	4.10

Regulator SW5 is provided with 2 bits to set its mode of operation.

- The SW5_RUN_MODE[1:0] bits allow the user to change the mode of operation of the SW5 regulators during the run state. If the regulator was programmed as part of the power up sequence, the SW5_RUN_MODE[1:0] bits are loaded with 0b11 (autoskip) by default. Otherwise, it is loaded with 0b00 (disabled).
- The SW5_STBY_MODE[1:0] bits allow the user to change the mode of operation of the SW5 regulators during the standby state. If the regulator was programmed as part of the power up sequence, the SW5_STBY_MODE[1:0] bits are loaded with 0b11 (autoskip) by default. Otherwise, it is loaded with 0b00 (disabled).

Table 53. SW5 regulator mode configuration

SW5_MODE[1:0]	Mode of operation
00	OFF
01	PWM mode
10	PFM mode
11	Autoskip mode

The SW5_MODE_I interrupt asserts the INTB pin when the SW5 regulator has changed the mode of operation, provided the corresponding interrupt is not masked.

When device toggles from run to standby mode, the SW5 output voltage remains the same, unless the regulator is enabled/disabled by the corresponding SW5_RUN_MODE[1:0] or SW5_STBY_MODE[1:0] bits.

The SW5ILIM [1:0] bits are used to program the current limit detection level of SW5.

Table 54. SW5 current limit selection

SW5ILIM[1:0]	Typical current limit
00	2.1 A
01	2.6 A
10	3.0 A
11	4.5 A

The current limit specification is given with respect to the inductor peak current. To calculate the DC current at which the buck regulator enters into current limitation, it is necessary to calculate the inductor ripple current. An ideal approximation is enough to obtain the ripple current as follows:

$$\Delta i_L = V_{OUT} \times (1 - V_{OUT}/V_{IN}) / (L \times F_{SW})$$

L is the inductance value and FSW is the selected switching frequency.

The DC current limit is then calculated by:

$$DC\ ILIM = ILIM - (\Delta i_L / 2)$$

In order to account for component tolerances, use the minimum inductor value per the inductor specification.

Regulator SW5 uses 3 bits (SW5PHASE[2:0]) to control the phase shift of the switching frequency. The SW5 switching phase is loaded from the OTP_SW5PHASE[2:0] registers at power up, it can be modified during the system-on states.

Table 55. SW5 phase configuration

SW5_PHASE[2:0]	Phase shift (degrees)
000	45
001	90
010	135
011	180
100	225
101	270
110	315
111	0

SW5 buck regulator provides two OTP bits to configure the value of the inductor used in the power stage. The OTP_SW5_LSELECT[1:0] allow to choose the inductor as shown in the following table.

Table 56. SW5 inductor selection bits

OTP_SW5_LSELECT[1:0]	Inductor value
00	1.0 μH
01	0.47 μH
10	1.5 μH
11	Reserved

15.4.1 Electrical characteristics

Table 57. Type 2 buck regulator electrical characteristics

All parameters are specified at $T_A = -40\text{ }^\circ\text{C}$ to $125\text{ }^\circ\text{C}$ for AEC-Q100 grade 1 device, all parameters are specified at $T_A = -40\text{ }^\circ\text{C}$ to $105\text{ }^\circ\text{C}$ for AEC-Q100 grade 2 device, $V_{IN} = V_{SW5IN} = UVDET$ to 5.5 V , $V_{SW5FB} = 1.8\text{ V}$, $I_{SW5} = 500\text{ mA}$, typical external component values, $f_{SW} = 2.25\text{ MHz}$, unless otherwise noted. Typical values are characterized at $V_{IN} = V_{SW5IN} = 5.0\text{ V}$, $V_{SW5FB} = 1.8\text{ V}$, $I_{SW5} = 500\text{ mA}$, and $T_A = 25\text{ }^\circ\text{C}$, unless otherwise noted.

Symbol	Parameter	Min	Typ	Max	Unit
$V_{SW5IN}^{[1]}$	Operating input voltage range $1.2\text{ V} < V_{SW5FB} \leq 1.85\text{ V}$, $DCR \leq 40\text{ m}\Omega$	UVDET	—	5.5	V
$V_{SW5IN}^{[1]}$	Operating input voltage range $1.85\text{ V} < V_{SW5FB} < 4.1\text{ V}$, $DCR \leq 40\text{ m}\Omega$	$V_{SW5FB} + 0.65$	—	5.5	V
V_{SW5ACC}	Output voltage accuracy PWM mode $0 \leq I_{SW5} \leq 2.5\text{ A}$	-2.0	—	2.0	%
V_{SW5ACC}	Output voltage accuracy PFM mode $0 \leq I_{SW5} \leq \Delta I/2$	-4.0	—	4.0	%
$t_{PFMtoPWM}$	PFM to PWM transition time	10	—	—	μs
$I_{SW5}^{[2]}$	Maximum output load	2500	—	—	mA
I_{SW5LIM}	Current limiter - inductor peak current detection SW5ILIM = 00	1.6	2.1	2.5	A
I_{SW5LIM}	Current limiter - inductor peak current detection SW5ILIM = 01	2.0	2.6	3.1	A
I_{SW5LIM}	Current limiter - inductor peak current detection SW5ILIM = 10	2.4	3.0	3.7	A
I_{SW5LIM}	Current limiter - inductor peak current detection SW5ILIM = 11	3.6	4.5	5.45	A
$I_{SW5NILIM}$	Negative current limit - inductor valley current detection	0.7	1.0	1.3	A
$t_{SW5RAMP}$	Soft-start ramp time during power up and power down $V_{SW5FB} = 1.8\text{ V}$	90	—	200	μs
t_{ONSW5}	Turn on time From regulator enabled to 90 % of end value $V_{SW5FB} = 1.8\text{ V}$	100	180	300	μs
V_{SW5OSH}	Startup overshoot	-50	—	50	mV
η_{SW5}	Efficiency PFM mode, 3.3 V, 1.0 mA, $T_J = 125\text{ }^\circ\text{C}$	—	85	—	%
η_{SW5}	Efficiency PFM mode, 3.3 V, 50 mA, $T_J = 125\text{ }^\circ\text{C}$	—	88	—	%
η_{SW5}	Efficiency PFM mode, 3.3 V, 100 mA, $T_J = 125\text{ }^\circ\text{C}$	—	90	—	%
η_{SW5}	Efficiency PWM mode, 3.3 V, 400 mA, $T_J = 125\text{ }^\circ\text{C}$	—	91	—	%
η_{SW5}	Efficiency PWM mode, 3.3 V, 1000 mA, $T_J = 125\text{ }^\circ\text{C}$	—	92	—	%
η_{SW5}	Efficiency PWM mode, 3.3 V, 2000 mA, $T_J = 125\text{ }^\circ\text{C}$	—	90	—	%
f_{SW5}	PWM switching frequency range Frequency set by CLK_FREQ[3:0]	1.9	2.5	3.15	MHz
$T_{ONminSW5}$	Minimum on time	—	50	—	ns
T_{DBSW5}	Deadband time	—	3.0	—	ns
T_{slew}	Slewing time 10 % to 90 % $V_{SW5IN} = 5.5\text{ V}$	—	—	5.0	ns

7-channel power management integrated circuit for high performance applications

Symbol	Parameter	Min	Typ	Max	Unit
ΔV_{SW5}	Output ripple Output cap ESR ~ 10 m Ω , 2 x 22 μ F	-1.0	—	1.0	%
$V_{SW5LOTR}$	Transient load regulation (overshoot/undershoot) Transient load = 200 mA to 1.0 A step di/dt = 2.0 A/ms Cout = 44 μ F $V_{SW5FB} = 1.8$ V	-50	—	50	mV
I_{RCS}	DCM (skip mode) reverse current sense threshold	—	10	—	mA
I_{SW5Q}	Quiescent current PFM mode	—	18	—	μ A
I_{SW5Q}	Quiescent current Auto skip mode	—	150	250	μ A
$R_{ONSW5HS}$	SW5 high-side P-MOSFET $R_{DS(on)}$	—	—	135 ^[3]	m Ω
$R_{ONSW5LS}$	SW5 low-side N-MOSFET $R_{DS(on)}$	—	—	80 ^[3]	m Ω
R_{SW5DIS}	SW5 discharge resistance (normal operation)	—	70	120	Ω
R_{SW5TBB}	SW5 discharge resistance during TBB mode TBBEN = 1 and QPU_OFF state	1.0	2.0	3.0	K Ω

- [1] VSW5IN must be connected to VIN to ensure proper device operation.
 [2] The Type 2 buck regulator is capable of providing output current above the nominal max current specification as long as it does not reach the current limitation. However, if operating above the nominal maximum current, overall thermal considerations must be taken to prevent reaching PMIC thermal shutdown during high ambient temperature conditions.
 [3] Max $R_{DS(on)}$ does not include bond wire resistance. Consider ± 50 % tolerance to account for bond wire and pin loss.

Table 58. Recommended external components

Symbol	Parameter	Min	Typ	Max	Unit
L	Output inductor Maximum inductor DC resistance 50 m Ω ^[1] Minimum saturation current at full load: 3.0 A	0.47	1.0	1.5	μ H
C _{out}	Output capacitor Use 2 x 22 μ F, 6.3 V X7T ceramic capacitor to reduce output capacitance ESR.	—	44	—	μ F
C _{in}	Input capacitor 4.7 μ F, 10 V X7R ceramic capacitor	—	4.7	—	μ F

- [1] Keep inductor DCR as low as possible to improve regulator efficiency.

15.5 Linear regulators

The PF7100 has two low drop-out (LDO) regulators with the following features:

- 400 mA current capability
- Input voltage range from 2.5 V to 5.5 V
- Programmable output voltage between 0.8 V and 5.0 V
- Soft-start ramp control during power up (enable)
- Discharge mechanism during power down (disable)
- OTP programmable load switch mode

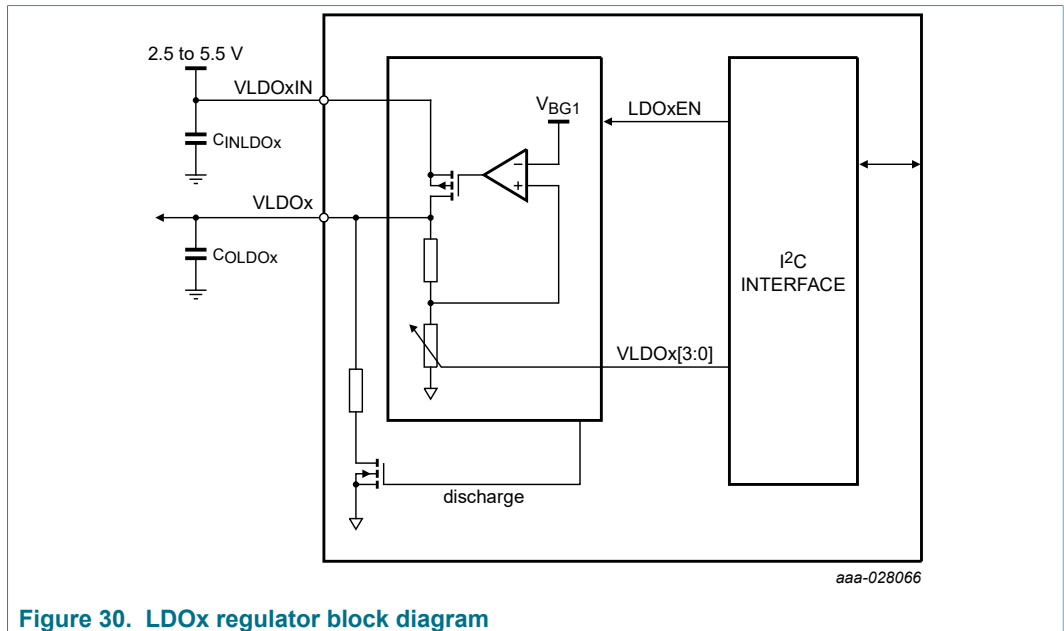

Figure 30. LDOx regulator block diagram

LDO1 and LDO2 have their own dedicated input supply pin, LDO1IN and LDO2IN respectively.

The two LDOs are provided with 1 bit to enable or disable its output during the system-on states.

- When LDOx_RUN_EN = 0, the LDO is disabled during the run mode. If the regulator is part of the power up sequence, this bit is set during the power up sequence. Otherwise it is defaulted to 0.
- When LDOx_STBY_EN = 0, the LDO is disabled during the standby mode. If the regulator is part of the power up sequence, this bit is set during the power up sequence. Otherwise it is defaulted to 0.

The mode of operation of the LDOx is selected on OTP via the OTP_LDOxLS bit.

Table 59. LDO operation description

LDOx_RUN_EN / LDOx_STBY_EN	OTP_LDOxLS	LDO operation mode (Run or standby mode)
0	X	Disabled with output pulldown active
1	0	Enabled in normal mode
1	1	Enabled in load switch configuration

The LDOs use 4 bits to set the output voltage.

- The VLDOx_RUN[3:0] sets the output voltage during the run mode.
- The VLDOx_STBY[3:0] sets the output voltage during standby mode.

The default output voltage configuration for the run and the standby modes is loaded from the OTP_VLDOx[3:0] registers on power up.

Table 60. LDO output voltage configuration

Set point	VLDOx_RUN[3:0] VLDOx_STBY[3 :0]	VLDOx output (V)
0	0000	0.8
1	0001	0.9
2	0010	1.0
3	0011	1.1
4	0100	1.2
5	0101	1.5
6	0110	1.6
7	0111	1.8
8	1000	1.85
9	1001	2.5
10	1010	3.0
11	1011	3.15
12	1100	3.3
13	1101	3.35
14	1110	4.5
15	1111	5.0

LDO2 can be controlled by hardware using the VSELECT and LDO2EN pins. When controlling the LDO2 by hardware, the output voltage can be selectable by the VSELECT pin as well as enabled/disabled by the LDO2EN pin.

15.5.1 LDO load switch operation

When the LDOxLS bit is set to 1, the corresponding LDO operates as a load switch, allowing a pass-through from the LDOxVIN to the corresponding LDOxVOUT output through a maximum 130 mΩ resistance. In this mode of operation, the input must be kept inside the LDO operating input voltage range (2.5 V to 5.5 V)

The LDOxEN bit is used to enable or disable the switch.

15.5.2 LDO regulator electrical characteristics

Table 61. LDO regulator electrical characteristics

All parameters are specified at $T_A = -40\text{ °C}$ to 125 °C for AEC-Q100 grade 1 device, all parameters are specified at $T_A = -40\text{ °C}$ to 105 °C for AEC-Q100 grade 2 device, $V_{LDOxIN} = 2.5\text{ V}$ to 5.5 V , $V_{LDOx} = 1.8\text{ V}$, $I_{LDOx} = 100\text{ mA}$, typical external component values, unless otherwise noted. Typical values are characterized at $V_{LDOxIN} = 5.5\text{ V}$, $V_{LDOx} = 1.8\text{ V}$, $I_{LDOx} = 100\text{ mA}$, and $T_A = 25\text{ °C}$, unless otherwise noted.

Symbol	Parameter	Min	Typ	Max	Units
V_{LDOxIN}	LDOx operating input voltage range $1.5\text{ V} \leq V_{LDOx} < 2.25\text{ V}$	2.5	—	5.5	V
V_{LDOxIN}	LDOx operating input voltage range $2.25\text{ V} < V_{LDOx} < 5.0\text{ V}$	$V_{LDOxNOM} + 0.25$	—	5.5	V
I_{LDOx}	Maximum load current	400	—	—	mA
$V_{LDOxTOL}$	Output voltage tolerance $0.8\text{ V} \leq V_{LDOx} \leq 1.2\text{ V}$ $0\text{ mA} < I_{LDOx} \leq 400\text{ mA}$	-35	—	35	mV

7-channel power management integrated circuit for high performance applications

Symbol	Parameter	Min	Typ	Max	Units
V _{LDOxTOL}	Output voltage tolerance 1.5 V ≤ V _{LDOx} ≤ 5.0 V 0 mA < I _{LDOx} ≤ 400 mA	-3.0	—	3.0	%
V _{LDOxLOR}	Load regulation	—	0.10	0.20	mV/mA
V _{LDOxLIR}	Line regulation	—	1.0	20	mV/V
I _{LDOxLIM}	Current limit I _{LDOx} when VLDOx is forced to V _{LDOxNOM} /2	450	850	1400	mA
I _{LDOxQ}	Quiescent current (measured at T _A = 25 °C)	—	7.0	10	μA
R _{DS(on)}	Drop-out/load switch on resistance V _{LDOINx} = 3.3 V (at T _J = 125 °C)	—	—	150 ^[1]	mΩ
PSRR _{VLDOx}	DC PSRR I _{LDOx} = 150 mA VLDOx[3:0] = 0000 to 1111 V _{LDOINx} = V _{LDOxNMIN}	48	—	—	dB
TR _{VLDOx}	Turn on rise time (soft-start ramp) 10 % to 90 % of end value V _{LDOx} = 3.3 V I _{LDOx} = 0.0 mA	—	220	360	μs
t _{ONLDOx}	Turn on time Enable to 90 % of end value V _{LDOx} = 5.0 V I _{LDOx} = 0.0 mA	—	—	400	μs
t _{OFFLDOx}	Turn off time Disable to 10 % of initial value V _{LDOx} = 5.0 V I _{LDOx} = 0.0 mA	—	—	3500	μs
V _{LDOxOSHT}	Startup overshoot V _{LDOINx} = V _{LDOxNMIN} V _{LDOx} = 5.0 V I _{LDOx} = 0.0 mA	—	1.0	2.0	%
V _{LDOxLOTR}	Transient load response I _{LDOx} = 10 mA to 200 mA in 2.0 μs Peak of overshoot or undershoot of LDOx with respect to final value 1.5 V ≤ VLDOx ≤ 5.0 V	-6.0	—	6.0	%
V _{LDOxLOTR}	Transient load response I _{LDOx} = 10 mA to 200 mA in 2.0 μs Peak of overshoot or undershoot of LDOx with respect to final value 0.8 V ≤ VLDOx ≤ 1.2 V	-90	—	90	mV
T _{onLDOxLS}	Load switch mode turn on rise time	—	150	300	μs
R _{dischLDOx}	Output discharge resistance when LDO is disabled LDO and switch mode	50	100	300	Ω
I _{LSxLIM}	Load switch mode current limit when enabled LSxLIM_EN = 1	450	850	1400	mA
R _{LDOxTBB}	LDOx pulldown resistance during TBB mode TBBEN = 1 & in QPU_OFF state	1.0	2.0	3.0	kΩ

[1] Max R_{DS(on)} does not include bond wire resistance. Consider 40 % tolerance to account for bond wire and pin loss.

15.6 Voltage monitoring

The PF7100 provides OV and UV monitoring capability for the following voltage regulators:

- SW1 to SW5

7-channel power management integrated circuit for high performance applications

- LDO1 and LDO2

A programmable UV threshold is selected via the OTP_SWxUV_TH[1:0] and OTP_LDOxUV_TH[1:0] bits. UV threshold selection represents a percentage of the nominal voltage programmed on each regulator.

Table 62. UV threshold configuration register

OTP_SWxUV_TH[1:0] OTP_LDOxUV_TH[1:0]	UV threshold level
00	95 %
01	93 %
10	91 %
11	89 %

A programmable OV threshold is selected via the OTP_SWxOV_TH[1:0] and OTP_LDOxOV_TH[1:0] bits. OV threshold selection represents a percentage of the nominal voltage programmed on each regulator.

Table 63. OV threshold configuration register

OTP_SWxOV_TH OTP_LDOxOV_TH	OV threshold level
00	105 %
01	107 %
10	109 %
11	111 %

Two functional bits are provided to program the UV debounce time for all the voltage regulators.

Table 64. UV debounce timer configuration

UV_DB[1:0]	UV debounce time
00	5 μs
01	15 μs
10	25 μs
11	40 μs

The default value of the UV_DB[1:0] upon a full register reset is 0b10.

Two functional bits to program the OV debounce time for all the voltage regulators.

Table 65. OV debounce timer configuration

OV_DB[1:0]	OV debounce time
00	30 μs
01	50 μs
10	80 μs
11	125 μs

The default value of the OV_DB[1:0] upon a full register reset is 0b00.

The VMON_EN bits enable or disable the OV/UV monitor for each one of the external regulators (SWxVMON_EN, LDOxVMON_EN).

7-channel power management integrated circuit for high performance applications

- When the VMON_EN bit of a specific regulator is 1, the voltage monitor for that specific regulator is enabled.
- When the VMON_EN bit of a specific regulator is 0, the voltage monitor for that specific regulator is disabled.

By default, the VMON_EN bits are set to 1 on power up.

When the I2C_SECURE_EN = 1, a secure write must be performed to set or clear the VMON_EN bits to enable or disable the voltage monitoring for a specific regulator.

On enabling a regulator, the UV/OV monitor is masked until the corresponding regulator reaches the point of regulation. If a voltage monitor is disabled, the UV_S and OV_S indicators from that monitor are reset to 0.

15.6.1 Voltage monitoring architecture

[Figure 31](#) shows the voltage monitoring architecture.

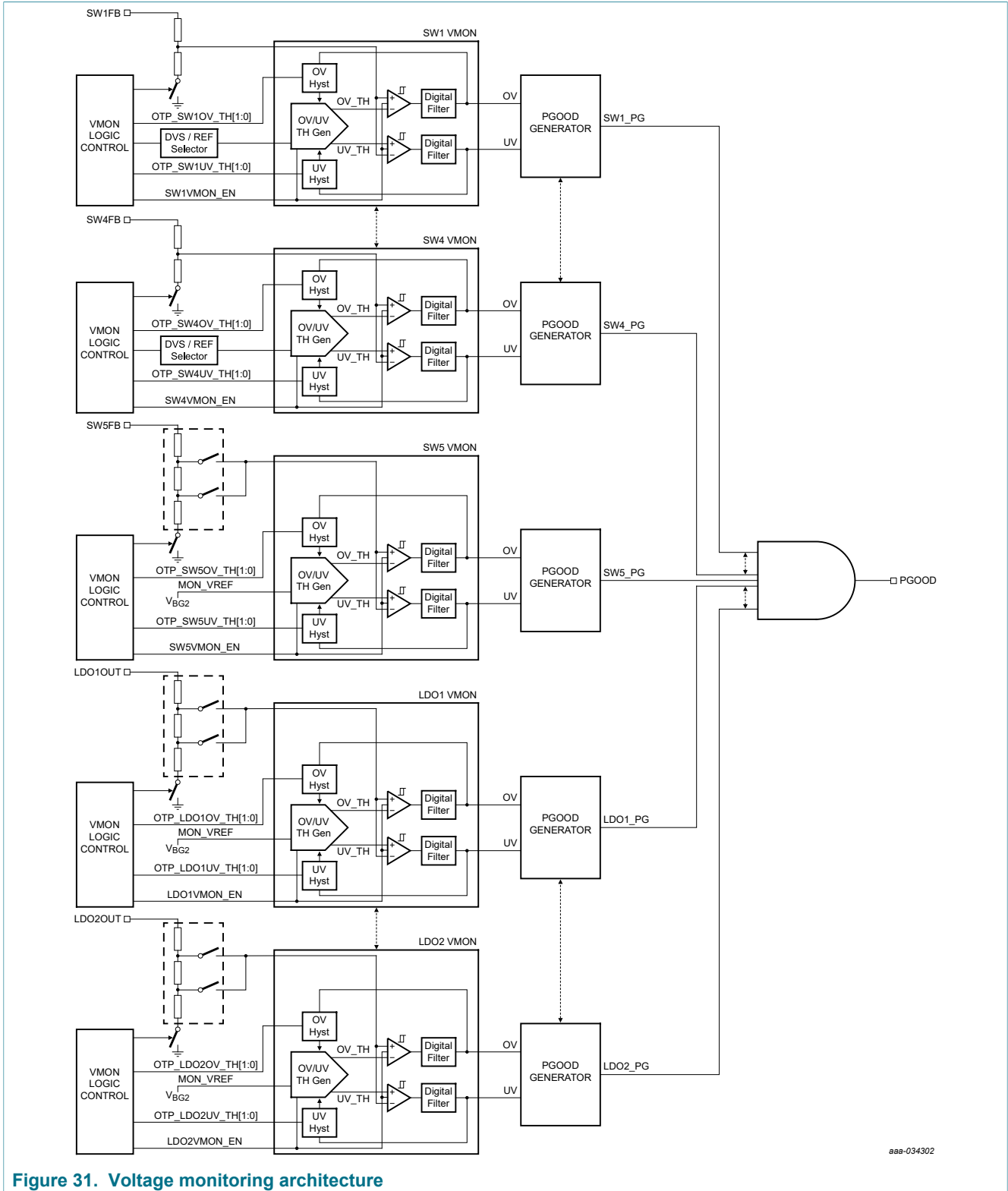

Figure 31. Voltage monitoring architecture

15.6.2 Electrical characteristics

Table 66. VMON electrical characteristics

All parameters are specified at $T_A = -40\text{ }^\circ\text{C}$ to $125\text{ }^\circ\text{C}$ for AEC-Q100 grade 1 device, all parameters are specified at $T_A = -40\text{ }^\circ\text{C}$ to $105\text{ }^\circ\text{C}$ for AEC-Q100 grade 2 device, unless otherwise noted. Typical values are characterized at $V_{IN} = 5.0\text{ V}$, $V_{xFB} = 1.5\text{ V}$ (Type 1 buck regulator), 3.3 V (Type 2 buck regulator, LDO regulator), and $T_A = 25\text{ }^\circ\text{C}$, unless otherwise noted.

Symbol	Parameter	Min	Typ	Max	Unit
I_{QON}	Block quiescent current, when block is enabled One block per regulator	—	10	13	μA
I_{OFF}	Block leakage current when disabled	—	—	500	nA
t_{ON_MON}	Voltage monitor settling time after enabled	—	—	30	μs
$V_{xFBUVHysteresis}$	Power good (UV) hysteresis Voltage difference between UV rising and falling thresholds	—	0.5	—	%
V_{UV_Tol}	Undervoltage falling threshold accuracy With respect to target feedback voltage tolerance For type 2 switching regulator and LDO regulator For type 1 switching regulator when $V_{SWxFB} > 0.75\text{ V}$	-2	—	2	%
V_{UV_Tol}	Under voltage falling threshold accuracy With respect to target feedback voltage For type 1 switching regulator when $V_{SWxFB} \leq 0.75\text{ V}$	-3	—	3	%
t_{UV_DB}	Power good (UV) debounce time UV_DB = 00	2.5	5.0	7.5	μs
	Power good (UV) debounce time UV_DB= 01	10	15	20	
	Power good (UV) debounce time UV_DB= 10	20	30	40	
	Power good (UV) debounce time UV_DB = 11	25	40	55	
V_{OV_Tol}	Overvoltage rising threshold accuracy With respect to target feedback voltage tolerance For type 2 switching regulator and LDO regulators For type 1 switching regulator when $V_{SWxFB} > 0.75\text{ V}$	-2	—	2	%
V_{OV_Tol}	Overvoltage rising threshold With respect to target feedback voltage tolerance For type 1 switching regulator when $V_{SWxFB} \leq 0.75\text{ V}$	-3	—	3	%
$V_{xFBOVHysteresis}$	Overvoltage (OV) hysteresis Voltage difference between OV rising and falling thresholds	0.5	—	1.0	%
t_{OV_DB}	Overvoltage (OV) debounce time OV_DB = 00	20	30	40	μs
	Overvoltage (OV) debounce time OV_DB = 01	35	50	65	
	Overvoltage (OV) debounce time OV_DB = 10	55	80	105	
	Overvoltage (OV) debounce time OV_DB = 11	90	125	160	

15.7 Clock management

The clock management provides a top-level management control scheme of internal clock and external synchronization intended to be primarily used for the switching regulators. The clock management incorporates various subblocks:

- Low power 100 kHz clock
- Internal high frequency clock with programmable frequency
- Phase-Locked Loop (PLL)

A digital clock management interface is in charge of supporting interaction among these blocks.

The clock management provides clocking signals for the internal state machine, the switching frequencies for the seven buck converters as well as the multiples of those switching frequencies in order to enable phase shifting for multiple phase operations.

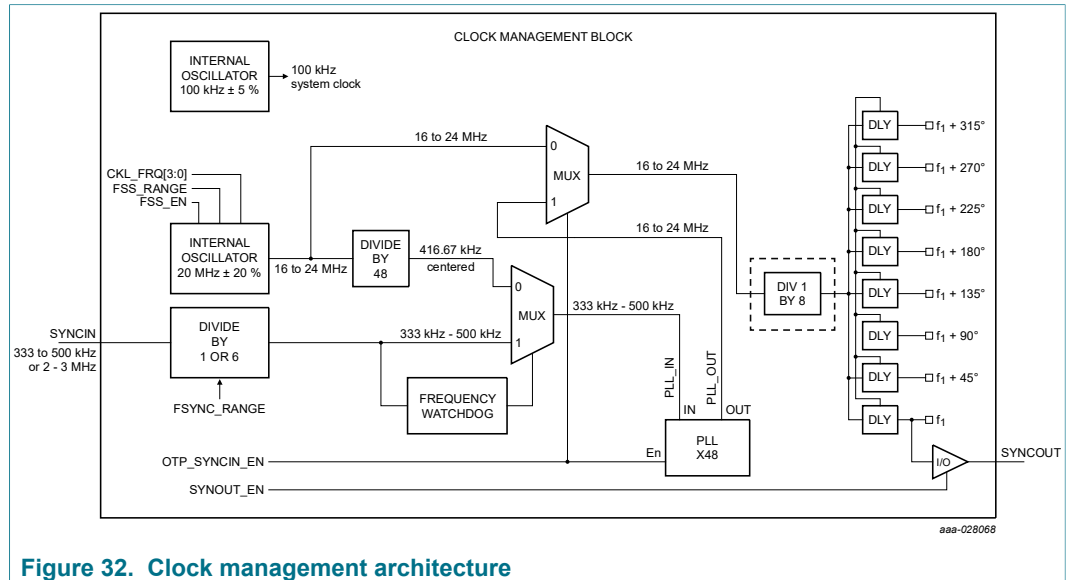

Figure 32. Clock management architecture

15.7.1 Low frequency clock

Low power 100 kHz clock is provided for overall logic and digital control. Internal logic and debounce timers are based on this 100 kHz clock.

15.7.2 High frequency clock

The PF7100 features a high frequency clock with nominal frequency of 20 MHz. Clock frequency is programmable over a range of $\pm 20\%$ via the CLK_FREQ[3:0] control bits.

15.7.3 Manual frequency tuning

The PF7100 features a manual frequency tuning to set the switching frequency of the high frequency clock. The CLK_FREQ [3:0] bits allow a manual frequency tuning of the high frequency clock from 16 MHz to 24 MHz.

If a frequency change of two or more steps is requested by a single I²C command, the device performs a gradual frequency change passing through all steps in between with a 5.2 μ s time between each frequency step. When the frequency reaches the programmed value, the FREQ_RDY_I asserts the INTB pin, provided it is not masked.

When the internal clock is used as the main frequency for the power generation, an internal frequency divider by 8 is used to generate the switching frequency for all the buck regulators. Adjusting the frequency of the high frequency clock allows for manual tuning of the switching frequencies for the buck regulators from 2.0 MHz to 3.0 MHz.

Table 67. Manual frequency tuning configuration

CLK_FREQ[3:0]	High speed clock frequency (MHz)	Switching regulators frequency (MHz)
0000	20	2.500
0001	21	2.625
0010	22	2.750
0011	23	2.875
0100	24	3.000
0101	Not used	Not used
0110	Not used	Not used
0111	Not used	Not used
1000	Not used	Not used
1001	16	2.000
1010	17	2.125
1011	18	2.250
1100	19	2.375
1101	Not used	Not used
1110	Not used	Not used
1111	Not used	Not used

The default switching frequency is set by the OTP_CLK_FREQ[3:0] bits.

Manual tuning cannot be applied when frequency spread-spectrum or external clock synchronization is used. However, during external clock synchronization, it is recommended to program the CLK_FREQ[3:0] bits to match the external frequency as close as possible.

15.7.4 Spread-spectrum

The internal clock provides a programmable frequency spread spectrum with two ranges for narrow spread and wide spread to help manage EMC in the automotive applications.

- When the FSS_EN = 1, the frequency spread-spectrum is enabled.
- When the FSS_EN = 0, the frequency spread-spectrum is disabled.

The default state of the FSS_EN bit upon a power up can be configured via the OTP_FSS_EN bit.

The FSS_RANGE bit is provided to select the clock frequency range.

- When FSS_RANGE = 0, the maximum clock frequency range is $\pm 5\%$.
- When FSS_RANGE = 1, the maximum clock frequency range is $\pm 10\%$.

The default value of the FSS_RANGE bit upon a power up can be configured via the OTP_FSS_RANGE bit.

The frequency spread-spectrum is performed at a 24 kHz modulation frequency when the internal high frequency clock is used to generate the switching frequency for the switching regulators. When the external clock synchronization is enabled, the spread-spectrum is disabled.

The following figure shows implementation of spread-spectrum for the two settings.

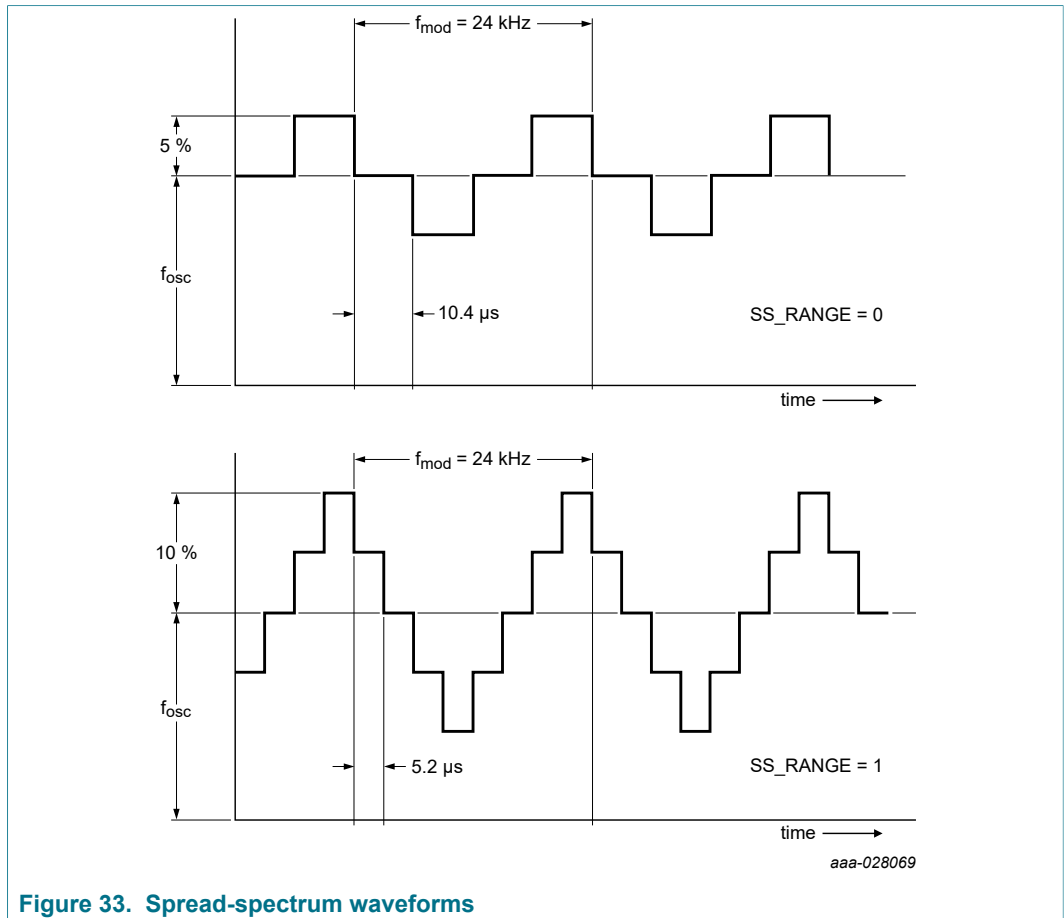

If the frequency spread-spectrum is enabled, the switching regulators should be set in PWM mode to ensure clock synchronization at all time.

If the external clock synchronization is enabled, (SYNCIN_EN = 1), the spread spectrum is disabled regardless of the value of the FSS_EN bit.

15.7.5 Clock synchronization

An external clock can be fed via the SYNCIN pin to synchronize the switching regulators to this external clock.

When the OTP_SYNCIN_EN = 0, the external clock synchronization is disabled. In this case, the PLL is disabled, and the device always uses the internal high frequency clock to generate the main frequency for the switching regulators.

When the OTP_SYNCIN_EN = 1, the external clock synchronization is enabled. In this case, the internal PLL is always enabled and it uses either the internal high frequency clock or the SYNCIN pin as its source to generate the main frequency for the switching regulators.

If the SYNCIN function is not used, the pin should be grounded. If the external clock is meant to start up after the PMIC has started, the SYNCIN pin must be maintained low until the external clock is applied.

The SYNCIN pin is prepared to detect clock signals with a 1.8 V or 3.3 V amplitude and within the frequency range set by the FSYNC_RANGE bit.

7-channel power management integrated circuit for high performance applications

- When the FSYNC_RANGE = 0, the input frequency range at SYNCIN pin should be between 2000 kHz and 3000 kHz.
- When the FSYNC_RANGE = 1, the input frequency range at SYNCIN pin should be between 333 kHz and 500 kHz.

The OTP_FSYNC_RANGE bit is used to select the default frequency range accepted in the SYNCIN pin.

The external clock duty cycle at the SYNCIN pin should be between 40 % and 60 %. An input frequency in the SYNCIN pin outside the range defined by the FSYNC_RANGE bit is detected as invalid. If the external clock is not present or invalid, the device automatically switches to the internal clock and sets the FSYNC_FLT_I interrupt, which in turn asserts the INTB pin provided it is not masked.

The FSYNC_FLT_S bit is set to 1 as long as the input frequency is not present or invalid, and it is cleared to 0 when the SYNCIN has a valid input frequency.

The device switches back to the external switching frequency only when both, the FSYNC_FLT_I interrupt has been cleared and the SYNCIN pin sees a valid frequency.

When the external clock is selected, the switching regulators should be set in PWM mode to ensure clock synchronization at all time.

Upon an external clock failure, the MCU should verify the integrity of the external clock by implementing a three-step diagnostic strategy.

1. MCU acknowledges and finds the source of the interrupt event.
2. The interrupt is generated by the FSYNC_FLT_I event, the MCU reads the FSYNC_FLT_S bit to verify if the fault condition is persistent or not.
3. a. If FSYNC_FLT_S bit is 0, the fault condition can be considered as a transient condition and the system is ready to switch over to the external clock by clearing the FSYNC_FLT_I flag.
b. If the FSYNC_FLT_S bit is 1, the fault is considered a persistent fault and the MCU must take corrective action to send the system to safe operation.

The system designer is responsible to define the tolerance time to allow the external frequency to be lost before taking a corrective action such as stopping the system or placing the system in safe state in safety-related applications.

The SYNCOUT pin is used to synchronize an external device to the PF7100.

The SYNCOUT pin outputs the main frequency used for the switching regulators in the range of 2.0 MHz to 3.0 MHz. The SYNCOUT_EN bit can be used to enable or disable the SYNCOUT feature via I²C during the system-on states.

- When SYNCOUT_EN = 0, the SYNCOUT feature is disabled and the pin is internally pulled to ground.
- When SYNCOUT_EN = 1, the SYNCOUT pin toggles at the base frequency used by the switching regulators.

The SYNCOUT function can be enabled or disabled by default by using the OTP_SYNCOUT_EN bit.

7-channel power management integrated circuit for high performance applications

Table 68. Clock management specifications

All parameters are specified at $T_A = -40\text{ °C}$ to 125 °C for AEC-Q100 grade 1 device, all parameters are specified at $T_A = -40\text{ °C}$ to 105 °C for AEC-Q100 grade 2 device, unless otherwise noted. Typical values are characterized at $V_{IN} = 5.0\text{ V}$ and $T_A = 25\text{ °C}$, unless otherwise noted.

Symbol	Parameter	Min	Typ	Max	Unit
Low frequency clock					
$I_{Q100kHz}$	100 kHz clock quiescent current	—	—	3.0	μA
$f_{100kHzACC}$	100 kHz clock accuracy	-5.0	—	5.0	%
High frequency clock					
f_{20MHz}	High frequency clock nominal frequency via CLK_FREQ[3:0] = 0000	—	20	—	MHz
$f_{20MzACC}$	High frequency clock accuracy	-6.0	—	6.0	%
$t_{20MHzStep}$	Clock step transition time Minimum time to transition from one frequency step to the next in manual tuning mode	—	5.2	—	μs
FSS _{RANGE}	Spread-spectrum range FSS_RANGE = 0 via CLK_FREQ[3:0] Spread-spectrum is done around center frequency of 20 MHz	—	± 5.0	—	%
FSS _{RANGE}	Spread-spectrum range FSS_RANGE = 1 via CLK_FREQ[3:0] Spread-spectrum is done around center frequency of 20 MHz	—	± 10	—	%
FSS _{mod}	Spread spectrum frequency modulation	—	24	—	kHz
Clock synchronization					
f_{SYNCIN}	SYNCIN input frequency range FSYNC_RANGE = 0	2000	—	3000	kHz
f_{SYNCIN}	SYNCIN input frequency range FSYNC_RANGE = 1	333	—	500	kHz
$f_{SYNCOUT}$	SYNCOUT output frequency range via CLK_FREQ[3:0]	2000	—	3000	kHz
$V_{SYNCINLO}$	Input frequency low voltage threshold	—	—	$0.3 \cdot V_{DDIO}$	V
$V_{SYNCINHI}$	Input frequency high voltage threshold	$0.7 \cdot V_{DDIO}$	—	—	V
R_{PD_SYNCIN}	SYNCIN internal pull down resistance	0.475	1.0	—	$\text{M}\Omega$
$V_{SYNCOUTLO}$	Output frequency low voltage threshold	0	—	0.4	V
$V_{SYNCOUTH}$	Output frequency high voltage threshold	$V_{DDIO} - 0.5$	—	—	V

15.8 Thermal monitors

The PF7100 features seven temperature sensors spread around the die. These sensors are at the following locations:

1. Center of die	6. Vicinity of SW5
2. Vicinity of SW1	7. Vicinity of LDO1-2
3. Vicinity of SW2	
4. Vicinity of SW3	
5. Vicinity of SW4	

7-channel power management integrated circuit for high performance applications

Symbol	Parameter ^[1]	Min	Typ	Max	Unit
t _{temp_db}	Debounce timer for temperature thresholds (bidirectional)	—	10	—	µs
t _{interval}	Sampling interval time When TMP_MON_AON = 1	—	3.0	—	ms
t _{window}	Sampling window When TMP_MON_AON = 1	—	450	—	µs

[1] Sensor temperature is calculated with the following formula: $T [^{\circ}\text{C}] = (V_{\text{TSENSE}} - 1.498 \text{ V}) / \text{TCOF}$, where V_{TSENSE} is the thermal sensor voltage measured on the corresponding AMUX channel.

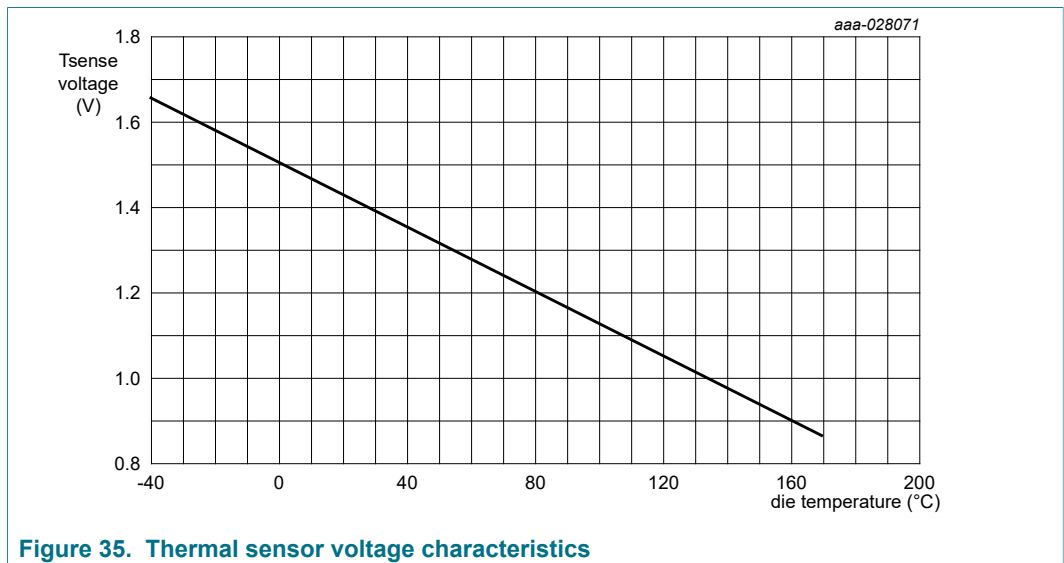

Figure 35. Thermal sensor voltage characteristics

As the temperature crosses the thermal thresholds, the corresponding interrupts are set to notify the system. The processor may take appropriate action to bring down the temperature (either by turning off external regulators, reducing load, or turning on a fan).

A 5 °C hysteresis is implemented on a falling temperature in order to release the corresponding THERM_x_S signal. When the shutdown threshold is crossed, the PF7100 initiates a thermal shutdown and it prevents from turning back on until the 15 °C thermal shutdown hysteresis is crossed as the device cools down.

The temperature monitor can be enabled or disabled via I²C with the TMP_MON_EN bit.

- When TMP_MON_EN = 0, the temperature monitor circuit is disabled.
- When TMP_MON_EN = 1, the temperature monitor circuit is enabled.

In the run state, the temperature sensor can operate in always on or sampling modes.

- When the TMP_MON_AON = 1, the device is always on during the run mode.
- When the TMP_MON_AON = 0, the device operates in sampling mode to reduce current consumption in the system. In sampling mode, the thermal monitor is turned on during 450 µs at a 3.0 ms sampling interval.

In the standby mode, the thermal monitor operates only in sampling mode as long as the TMP_MON_EN = 1

7-channel power management integrated circuit for high performance applications

Table 70. Thermal monitor bit description

Bit(s)	Description
THERM_80_I, THERM_80_S, THERM_80_M	Interrupt, sense, and mask bits for 80 °C threshold
THERM_95_I, THERM_95_S, THERM_95_M	Interrupt, sense, and mask bits for 95 °C threshold
THERM_110_I, THERM_110_S, THERM_110_M	Interrupt, sense, and mask bits for 110 °C threshold
THERM_125_I, THERM_125_S, THERM_125_M	Interrupt, sense, and mask bits for 125 °C threshold
THERM_140_I, THERM_140_S, THERM_140_M	Interrupt, sense, and mask bits for 140 °C threshold
THERM_155_I, THERM_155_S, THERM_155_M	Interrupt, sense, and mask bits for 155 °C threshold
TMP_MON_EN	Disables temperature monitoring circuits when cleared
TMP_MON_AON	When set, the temperature monitoring circuit is always ON. When cleared, the temperature monitor operates in sampling mode.

15.9 Analog multiplexer

An analog multiplexer (AMUX) is provided to allow access to various internal voltages within the PMIC. The selected voltage is buffered and made available on the AMUX output pin during the system-on states.

When the AMUX_EN bit is 0, the AMUX block is disabled and the output remains pulled down to ground.

When the AMUX_EN bit is 1, the AMUX block is enabled and the system may select the channel to be read by using the AMUX_SEL[4:0] bits.

Table 71. AMUX channel selection

AMUX_EN	AMUX_SEL[4:0]	AMUX selection	Internal signal dividing ratio
0	X XXXX	AMUX disabled and pin pulled down to ground	N/A
1	0 0000	AMUX disabled in high impedance mode	N/A
1	0 0001	VIN	4
1	0 0010	VSNVS1	3.5
1	0 0011	VSNVS2	2
1	0 0100	SW1_FB	1.25 (1.8 V setting) 1 (all other settings)
1	0 0101	SW2_FB	1.25 (1.8 V setting) 1 (All other settings)
1	0 0110	SW3_FB	1.25 (1.8 V setting) 1 (all other settings)
1	0 0111	SW4_FB	1.25 (1.8 V setting) 1 (all other settings)
1	0 1000	SW5_FB	10/3.5 = 2.86
1	0 1011	LDO1	10/5 = 2 (0.8 V to 1.2 V settings) 10/3 = 3.33 (1.5 V to 5.0 V settings)
1	0 1100	LDO2	10/5 = 2 (0.8 V to 1.2 V settings) 10/3 = 3.33 (1.5 V to 5.0 V settings)
1	0 1111	TEMP_IC	1

7-channel power management integrated circuit for high performance applications

AMUX_EN	AMUX_SEL[4:0]	AMUX selection	Internal signal dividing ratio
1	1 0000	TEMP_SW1	1
1	1 0001	TEMP_SW2	1
1	1 0010	TEMP_SW3	1
1	1 0011	TEMP_SW4	1
1	1 0100	TEMP_SW5	1
1	1 0111	TEMP_LDO1_2	1
1	Others	Reserved	N/A

All selectable Input signals are conditioned internally to fall within an operating output range from 0.3 V to 1.65 V. However, the AMUX pin is clamped to a maximum 2.5 V.

Table 72. AMUX specifications

Symbol	Parameter	Min	Typ	Max	Unit
V _{IN}	Operational voltage	UVDET	—	5.5	V
I _{REF}	Current reference range	0.95	1.0	1.05	μA
V _{OFFSET}	AMUX output voltage offset (input to output)	-6.25	—	6.25	mV
I _{QAMUX}	AMUX quiescent current	—	110	—	μA
t _{AMUX_ON}	AMUX settling time (off to channel transition) Max step size of 1.8 V; output cap 150 pF	—	—	50	μs
t _{AMUX_CHG}	AMUX settling time (channel to channel transition) Max step size of 1.8 V; output cap 150 pF	—	—	50	μs
V _{CLAMP}	AMUX clamping voltage	1.8	2.5	3.1	V
RA _{DIV_CH1}	Channel 1 Internal divider ratio Input source = VIN	3.97	4.0	4.05	—
RA _{DIV_CH2}	Channel 2 internal divider ratio Input source = VSNVS1	3.48	3.5	3.54	—
RA _{DIV_CH3}	Channel 3 internal divider ratio Input source = VSNVS2	1.98	2.0	2.02	—
RA _{DIV_CH4_7}	Channel 4 to 7 internal divider ratio Input source = SW1 to SW4 at 1.8 V configuration	1.241	1.25	1.267	—
RA _{DIV_CH8}	Channel 8 internal divider ratio Input source = VSW5	2.85	2.86	2.91	—
RA _{DIV_CH11_12}	Channel 11 to 12 internal divider ratio Input source = LDO1 to LDO2 1.5 V ≤ VLDOx ≤ 5.0 V	3.32	3.35	3.39	—
RA _{DIV_CH11_12}	Channel 11 to 12 internal divider ratio Input source = LDO1 to LDO2 0.8 V ≤ VLDOx ≤ 1.2 V	1.98	2.0	2.02	—

15.10 Watchdog event management

A watchdog event may be started in two ways:

- The WDI pin toggles low due to a watchdog failure on the MCU
- The internal watchdog expiration counter reaches the maximum value the WD timer is allowed to expire

A watchdog event initiated by the WDI pin may perform a hard WD reset or a soft WD reset as defined by the WDI_MODE bit. A watchdog event initiated by the internal watchdog always performs a hard WD reset.

15.10.1 Internal watchdog timer

The internal WD timer counts up and expires when it reaches the value in the WD_DURATION[3:0] register. When the WD timer starts counting, the WD_CLEAR flag is set to 1. Clearing the WD_CLEAR flag within the valid window is interpreted as a successful watchdog refresh and the WD timer gets reset. The MCU must write a 1 to clear the WD_CLEAR flag.

The WD timer is reset when device goes into any of the OFF modes and does not start counting until RESETBMCU is deasserted in the next power up sequence.

The OTP_WD_DURATION[3:0] selects the initial configuration for the watchdog window duration between 1.0 ms and 32768 ms (typical values).

The watchdog window duration can change during the system-on states by modifying the WD_DURATION[3:0] bits on the functional register map. If the WD_DURATION[3:0] bits get changed during the system-on states, the WD timer is reset.

Table 73. Watchdog duration register

WD_DURATION[3:0]	Watchdog timer duration (ms)
0000	1
0001	2
0010	4
0011	8
0100	16
0101	32
0110	64
0111	128
1000	256
1001	512
1010	1024
1011	2048
1100	4096
1101	8192
1110	16384
1111	32768

The WD_EXPIRE_CNT[2:0] counter is used to ensure that no cyclic watchdog condition occurs. When the WD_CLEAR flag is cleared successfully before the WD timer expires, the WD_EXPIRE_CNT[2:0] is decreased by 1. Every time the WD timer is not successfully refreshed, it gets reset and starts a new count and the WD_EXPIRE_CNT[2:0] is increased by 2.

If WD_EXPIRE_CNT[2:0] = WD_MAX_EXPIRE[2:0], a WD event is initiated. The default maximum amount of time the watchdog can expire before starting a WD reset is set by the OTP_WD_MAX_EXPIRE[2:0]. Writing a value less than or equal to 0x02 on the

7-channel power management integrated circuit for high performance applications

OTP_WD_MAX_EXPIRE causes the watchdog event to be initiated, as soon as the WD timer expires for the first time.

The OTP_WDWINDOW bit selects whether the watchdog is single ended or window mode.

- When OTP_WDWINDOW = 0, the WD_CLEAR flag can be cleared within 100 % of the watchdog timer.
- When OTP_WDWINDOW = 1, the WD_CLEAR flag can only be cleared within the second half of the programmed watchdog timer. Clearing the WD_CLEAR flag within the first half of the watchdog window is interpreted as a failure to refresh the watchdog.

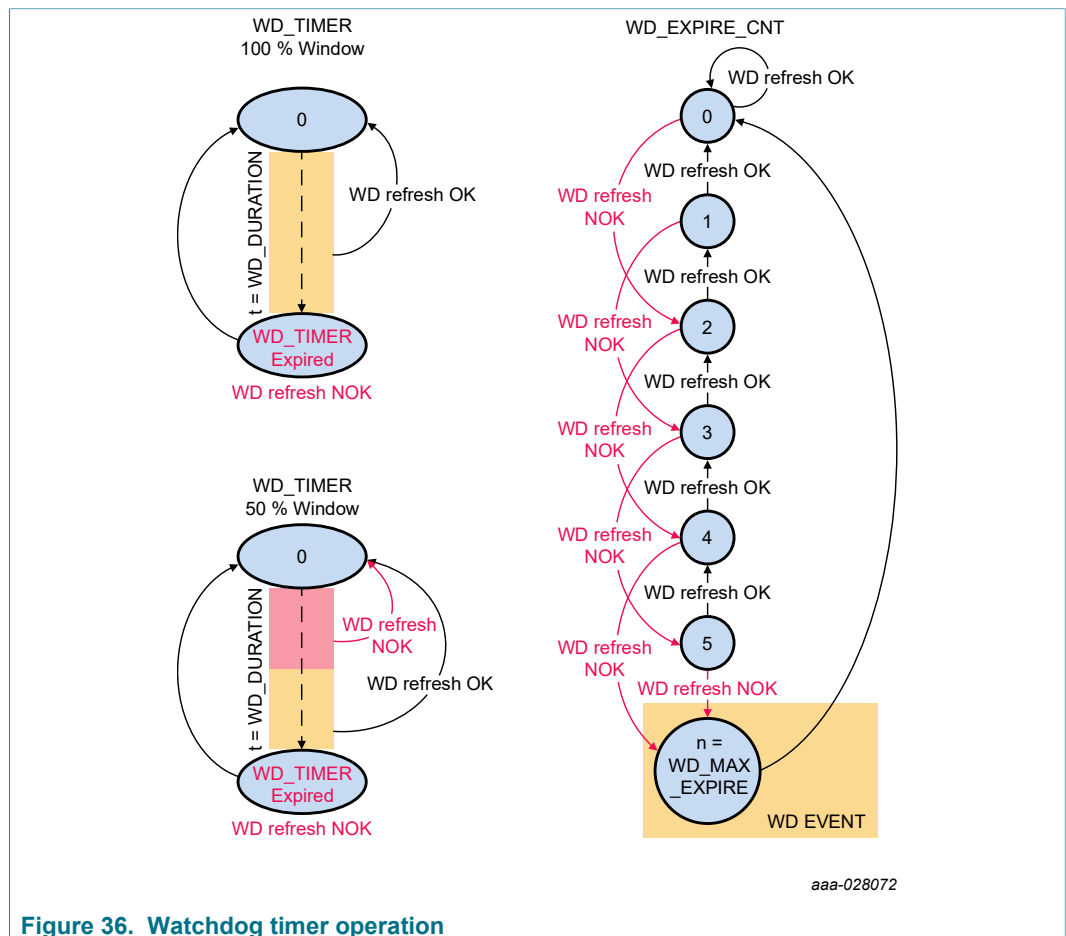

Figure 36. Watchdog timer operation

The watchdog function can be enabled or disabled by writing the WD_EN bit on the I²C register map. When the I2C_SECURE_EN = 1, a secure write must be performed to change the WD_EN bit.

- When WD_EN = 0, the internal watchdog timer operation is disabled.
- When WD_EN = 1, the internal watchdog timer operation is enabled.

The OTP_WD_EN bit is used to select the default status of the watchdog counter upon power up.

The watchdog function can be programmed to be enabled or disabled during the standby state by writing the WD_STBY_EN bit on the I²C register map. When the I2C_SECURE_EN = 1, a secure write must be performed to modify the WD_STBY_EN bit.

7-channel power management integrated circuit for high performance applications

- When WD_STBY_EN = 0, the internal watchdog timer operation during standby is disabled.
- When WD_STBY_EN = 1, the internal watchdog timer operation during standby is enabled.

The OTP_WD_STBY_EN bit selects whether the watchdog is active in standby mode by default or not.

15.10.2 Watchdog reset behaviors

When a watchdog event is started, a watchdog (WD) reset is performed. There are two types of watchdog reset:

- Soft WD reset
- Hard WD reset

A soft WD reset is used as a safe way for the MCU to force the PMIC to return to a known default configuration without forcing a POR Reset on the MCU. During a Soft WD reset, the RESETBMCU remains deasserted all the time.

Upon a soft WD reset, a partial OTP register reload is performed on the registers as shown in [Table 74](#).

Table 74. Soft WD register reset

Bit name	Register	Bits
Configuration registers		
STANDBYINV	CTRL2	2
RUN_PG_GPO	CTRL2	1
STBY_PG_GPO	CRTL2	0
RESETBMCU_SEQ[7:0]	RESETBMCU PWRUP	7:0
PGOOD_SEQ[7:0]	PGOOD PWRUP	7:0
WD_EN	CTRL1	3
WD_DURATION[3:0]	WD CONFIG	3:0
WD_STBY_EN	CTRL1	2
WDI_STBY_ACTIVE	CTRL1	1
SW registers		
SWx_WDBYPASS	SWx CONFIG1	1
SWx_PG_EN	SWx CONFIG1	0
SWxDVS_RAMP	SWx CONFIG2	6:5
SWxILIM[1:0]	SWx CONFIG2	4:3
SWxPHASE[2:0]	SWx CONFIG2	2:0
SWx_SEQ[7:0]	SWx PWRUP	7:0
SWx_PDGRP[1:0]	SWx MODE	5:4
SWx_STBY_MODE [1:0]	SWx MODE	3:2
SWx RUN_MODE [1:0]	SWx MODE	1:0
VSWx_RUN [7:0]	SWx RUN VOLT	7:0
VSWx_STBY [7:0]	SWx STBY VOLT	7:0
VSW5 [4:0]	SW5 VOLT	4:0
SW3_VTTEN	SW3_CONFIG2	6

Bit name	Register	Bits
LDO registers		
LDOx_WDBYPASS	LDOx CONFIG1	1
LDOx_PG_EN	LDOx CONFIG1	0
LDOx_PDGRP[1:0]	LDOx CONFIG2	6:5
LDO2HW_EN	LDO2 CONFIG2	4
VSELECT_EN	LDO2 CONFIG2	3
LDOx_RUN_EN	LDOx CONFIG2	1
LDOx_STBY_EN	LDOx CONFIG2	0
LDOx_SEQ [7:0]	LDOx PWRUP	7:0
VLDOx_RUN[3:0]	LDOx RUN VOLT	3:0
VLDOx_STBY[3:0]	LDOx STBY VOLT	3:0
AMUX_EN	AMUX	5

A soft WD reset may require all or some regulators to be reset to their default OTP configuration. In the event a regulator is required to keep its current configuration during a soft WD reset, a watchdog bypass bit is provided for each regulator (SWx_WDBYPASS / LDOx_WDBYPASS).

- When the WDBYPASS = 0, the watchdog bypass is disabled and the output of the corresponding regulator is returned to its default OTP value during the soft WD reset.
- When the WDBYPASS = 1, the watchdog bypass is enabled and the output of the corresponding regulator is not affected by the soft WD reset, keeping its current configuration.

During a soft WD reset, only regulators that are activated in the power up sequence go back to their default voltage configuration if their corresponding WDBYPASS = 0.

Switching regulators returning to their default voltage configurations gradually reach the new output voltage using its DVS configuration. LDO regulators returning to their default configuration changes to the default output voltage configuration instantaneously. Regulators with WDBYPASS = 0 and which are not activated during the power up sequence turn off immediately.

After all output voltages, have transitioned to their corresponding default values, the device waits for at least 30 μ s before returning to the run state and announces it has finalized the soft WD reset by asserting the INTB pin, provided the WDI_I interrupt is not masked.

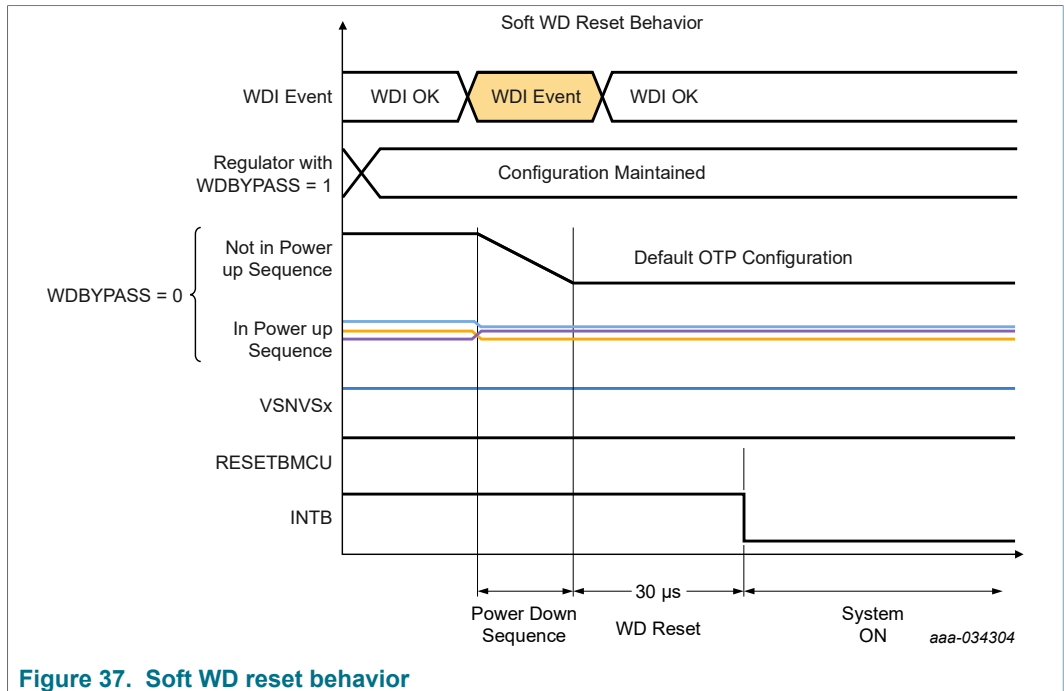

Figure 37. Soft WD reset behavior

A hard WD reset is used to force a system power-on reset when the MCU has become unresponsive. In this scenario, a full OTP register reset is performed.

During a hard WD reset, the device turns off all regulators and deasserts RESETBMCU as indicated by the power down sequence. If PGOOD is programmed as a GPO and configured as part of the power up sequence, it is disabled accordingly.

After all regulator outputs have gone through the power down sequence and the power down delay is finished, the device waits for 30 µs before reloading the default OTP configuration and get ready to start a power up sequence, if the XFAILB pin is not held low externally.

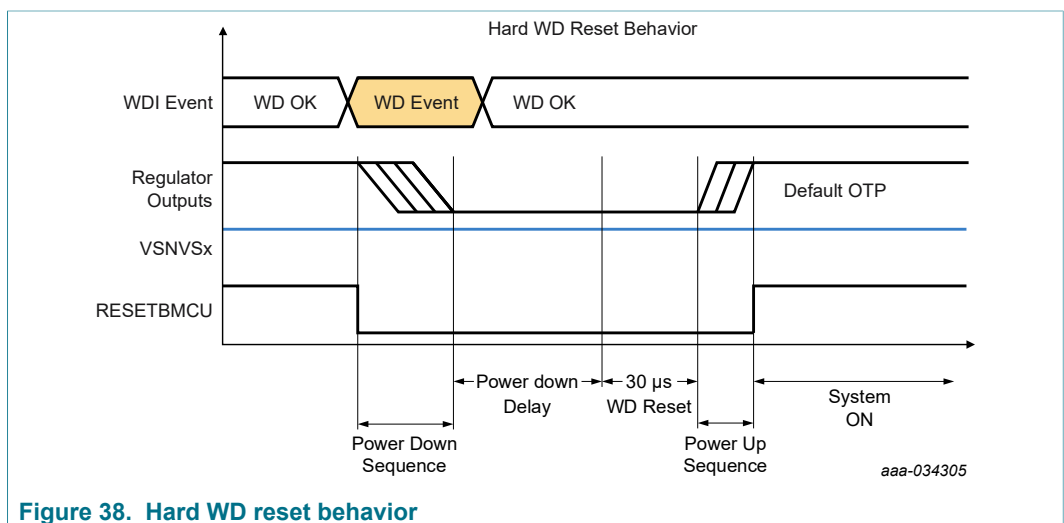

Figure 38. Hard WD reset behavior

After a WD reset, the PMIC may enter the standby state depending on the status of STANDBY pin.

Each time a WD event occurs, the WD_EVENT_CNT[3:0] nibble is incremented. To prevent continuous failures, if the WD_EVENT_CNT[3:0] = WD_MAX_CNT[3:0] the state machine proceeds to the fail-safe transition. The MCU is expected to clear the WD_EVENT_CNT[3:0] when it is able to do so in order to keep proper operation. Upon power up, the WD_MAX_CNT[3:0] is loaded with the values on the OTP_WD_MAX_CNT[3:0] bits.

Every time the device passes through the Off states, the WD_EVENT_CNT[3:0] is reset to 0x00, to ensure that the counter has a fresh start after a device power down.

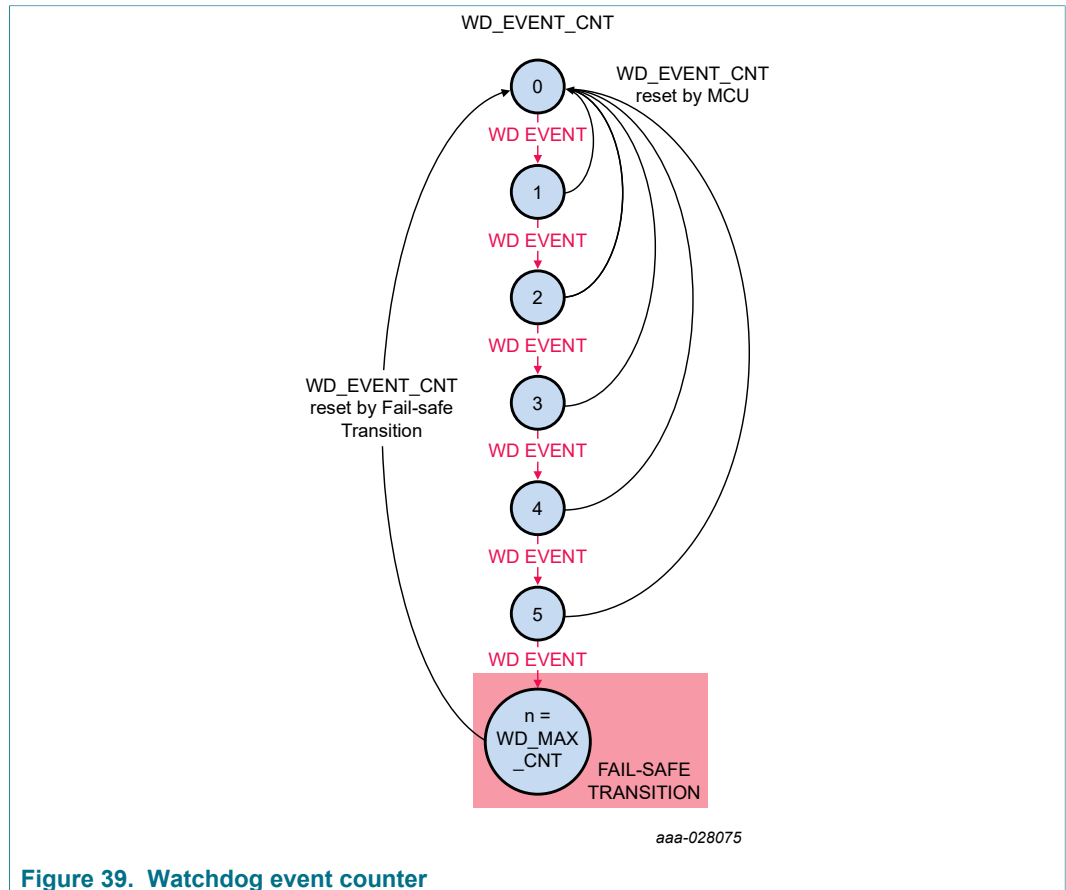

Figure 39. Watchdog event counter

16 I²C register map

The PF7100 provides a complete set of registers for control and diagnostics of the PMIC operation. The configuration of the device is done at two different levels.

At first level, the OTP Mirror registers provide the default hardware and software configuration for the PMIC upon power up. These are one-time programmable and should be defined during the system development phase, and are not meant to be modified during the application. See [Section 17 "OTP/TBB and hardware default configurations"](#) for more details on the OTP configuration feature.

At a second level, the PF7100 provides a set of functional registers intended for system configuration and diagnostics during the system operation. These registers are accessible during the system-on states and can be modified at any time by the System Control Unit.

7-channel power management integrated circuit for high performance applications

The device ID register provides general information about the PMIC.

- DEVICE_FAM[3:0]: indicates the PF7100 family of devices
1000 (fixed)
- DEVICE_ID[3:0]: provides the device type identifier
0000 = PF7100 Auto QM
1000 = PF7100 Auto ASIL B

Registers 0x02 and 0x03 provide a customizable program ID registers to identify the specific OTP configuration programmed in the part.

- EMREV (Address 0x02): contains the MSB bits PROG_ID[8:11]
- PROG_ID (Address 0x03): contains the LSB bit PROG_ID[7:0]

16.1 PF7100 ASIL B functional register map

RESET SIGNALS		R/W types	
UVDET	Reset when VIN crosses UVDET threshold	R	Read only
OFF_OTP	Bits are loaded with OTP values (mirror register)	R/W	Read and Write
OFF_TOGGLE	Reset when device goes to OFF mode	RW1C	Read, Write a 1 to clear
SC	Self-clear after write	R/SW	Read/Secure Write
NO_VSNVS	Reset when BOS has no valid input VIN < UVDET	R/TW	Read/Write on TBB only

AD DR	Register Name	R/W	BIT7	BIT6	BIT5	BIT4	BIT3	BIT2	BIT1	BIT0	
00	DEVICE ID	R	DEVICE_FAM[3:0]				DEVICE_ID[3:0]				
01	REV ID	R	FULL_LAYER_REV[3:0]				METAL_LAYER_REV[3:0]				
02	EMREV	R	PROG_IDH[11:8]					—	EMREV[2:0]		
03	PROG ID	R	PROG_IDL[7:0]								
04	INT STATUS1	RW1C	SDWN_I	FREQ_RDY_I	CRC_I	PWRUP_I	PWRDN_I	XINTB_I	FSOB_I	VIN_OVLO_I	
05	INT MASK1	R/W	SDWN_M	FREQ_RDY_M	CRC_M	PWRUP_M	PWRDN_M	XINTB_M	FSOB_M	VIN_OVLO_M	
06	INT SENSE1	R	—	—	—	—	—	XINTB_S	FSOB_S	VIN_OVLO_S	
07	THERM INT	RW1C	WDI_I	FSYNC_FLT_I	THERM_155_I	THERM_140_I	THERM_125_I	THERM_110_I	THERM_95_I	THERM_80_I	
08	THERM MASK	R/W	WDI_M	FSYNC_FLT_M	THERM_155_M	THERM_140_M	THERM_125_M	THERM_110_M	THERM_95_M	THERM_80_M	
09	THERM SENSE	R	WDI_S	FSYNC_FLT_S	THERM_155_S	THERM_140_S	THERM_125_S	THERM_110_S	THERM_95_S	THERM_80_S	
0A	SW MODE INT	RW1C	—	SW5_MODE_I	—	—	SW4_MODE_I	SW3_MODE_I	SW2_MODE_I	SW1_MODE_I	
0B	SW MODE MASK	R/W	—	SW5_MODE_M	—	—	SW4_MODE_M	SW3_MODE_M	SW2_MODE_M	SW1_MODE_M	
12	SW ILIM INT	RW1C	—	SW5_ILIM_I	—	—	SW4_ILIM_I	SW3_ILIM_I	SW2_ILIM_I	SW1_ILIM_I	
13	SW ILIM MASK	R/W	—	SW5_ILIM_M	—	—	SW4_ILIM_M	SW3_ILIM_M	SW2_ILIM_M	SW1_ILIM_M	
14	SW ILIM SENSE	R	—	SW5_ILIM_S	—	—	SW4_ILIM_S	SW3_ILIM_S	SW2_ILIM_S	SW1_ILIM_S	
15	LDO ILIM INT	RW1C	—	—	—	—	—	—	LDO2_ILIM_I	LDO1_ILIM_I	
16	LDO ILIM MASK	R/W	—	—	—	—	—	—	LDO2_ILIM_M	LDO1_ILIM_M	
17	LDO ILIM SENSE	R	—	—	—	—	—	—	LDO2_ILIM_S	LDO1_ILIM_S	
18	SW UV INT	RW1C	—	SW5_UV_I	—	—	SW4_UV_I	SW3_UV_I	SW2_UV_I	SW1_UV_I	
19	SW UV MASK	R/W	—	SW5_UV_M	—	—	SW4_UV_M	SW3_UV_M	SW2_UV_M	SW1_UV_M	
1A	SW UV SENSE	R	—	SW5_UV_S	—	—	SW4_UV_S	SW3_UV_S	SW2_UV_S	SW1_UV_S	
1B	SW OV INT	RW1C	—	SW5_OV_I	—	—	SW4_OV_I	SW3_OV_I	SW2_OV_I	SW1_OV_I	
1C	SW OV MASK	R/W	—	SW5_OV_M	—	—	SW4_OV_M	SW3_OV_M	SW2_OV_M	SW1_OV_M	
1D	SW OV SENSE	R	—	SW5_OV_S	—	—	SW4_OV_S	SW3_OV_S	SW2_OV_S	SW1_OV_S	
1E	LDO UV INT	RW1C	—	—	—	—	—	—	LDO2_UV_I	LDO1_UV_I	
1F	LDO UV MASK	R/W	—	—	—	—	—	—	LDO2_UV_M	LDO1_UV_M	
20	LDO UV SENSE	R	—	—	—	—	—	—	LDO2_UV_S	LDO1_UV_S	
21	LDO OV INT	RW1C	—	—	—	—	—	—	LDO2_OV_I	LDO1_OV_I	

7-channel power management integrated circuit for high performance applications

AD DR	Register Name	R/W	BIT7	BIT6	BIT5	BIT4	BIT3	BIT2	BIT1	BIT0
22	LDO OV MASK	R/W	—	—	—	—	—	—	LDO2_OV_M	LDO1_OV_M
23	LDO OV SENSE	R	—	—	—	—	—	—	LDO2_OV_S	LDO1_OV_S
24	PWRON INT	RW1C	BGMON_I	PWRON_8S_I	PWRON_4S_I	PRON_3S_I	PWRON_2S_I	PWRON_1S_I	PWRON_REL_I	PWRON_PUSH_I
25	PWRON MASK	R/W	BGMON_M	PWRON_8S_M	PWRON_4S_M	PRON_3S_M	PWRON_2S_M	PWRON_1S_M	PWRON_REL_M	PWRON_PUSH_M
26	PWRON SENSE	R	BGMON_S	—	—	—	—	—	—	PWRON_S
27	SYS INT	R	EWARN_I	PWRON_I	OV_I	UV_I	ILIM_I	MODE_I	STATUS2_I	STATUS1_I
29	HARD FAULT FLAGS	RW1C	—	—	—	—	PU_FAIL	WD_FAIL	REG_FAIL	TSD_FAIL
2A	FSOB FLAGS	R/SW	—	—	—	FSOB_ASS_NOK	FSOB_SFAULT_NOK	FSOB_WDI_NOK	FSOB_WDC_NOK	FSOB_HFAULT_NOK
2B	FSOB SELECT	R/W	—	—	—	—	FSOB_SOFTFAULT	FSOB_WDI	FSOB_WDC	FSOB_HARDFAULT
2C	ABIST OV1	R/SW	—	AB_SW5_OV	—	—	AB_SW4_OV	AB_SW3_OV	AB_SW2_OV	AB_SW1_OV
2D	ABIST OV2	R/SW	—	—	—	—	—	—	AB_LDO2_OV	AB_LDO1_OV
2E	ABIST UV1	R/SW	—	AB_SW5_UV	—	—	AB_SW4_UV	AB_SW3_UV	AB_SW2_UV	AB_SW1_UV
2F	ABIST UV2	R/SW	—	—	—	—	—	—	AB_LDO2_UV	AB_LDO1_UV
30	TEST FLAGS	R/W	—	—	—	LDO2EN_S	VSELECT_S	STEST_NOK	TRIM_NOK	OTP_NOK
31	ABIST RUN	R/SW	—	—	—	—	—	—	—	AB_RUN
33	RANDOM GEN	R	RANDOM_GEN[7:0]							
34	RANDOM CHK	R/W	RANDOM_CHK[7:0]							
35	VMONEN1	R/SW	—	SW5VMON_EN	—	—	SW4VMON_EN	SW3VMON_EN	SW2VMON_EN	SW1VMON_EN
36	VMONEN2	R/SW	—	—	—	—	—	—	LDO2VMON_EN	LDO1VMON_EN
37	CTRL1	R/SW	VIN_OVLO_EN	VIN_OVLO_SDWN	WDL_MODE	TMP_MON_EN	WD_EN	WD_STBY_EN	WDL_STBY_ACTIVE	I2C_SECURE_EN
38	CTRL2	R/W	VIN_OVLO_DBNCF[1:0]		—	TMP_MON_AON	LPM_OFF	STANDBYINV	RUN_PG_GPO	STBY_PG_GPO
39	CTRL3	R/W	OV_DB[1:0]		UV_DB[1:0]		—	—	PMIC_OFF	INTB_TEST
3A	PWRUP CTRL	R/W	—	PWRDWN_MODE	PGOOD_PDGRP[1:0]		RESETBMCU_PDGRP[1:0]		SEQ_TBASE[1:0]	
3C	RESETBMCU PWRUP	R/W	RESETBMCU_SEQ[7:0]							
3D	PGOOD PWRUP	R/W	PGOOD_SEQ[7:0]							
3E	PWRDN DLY1	R/W	GRP4_DLY[1:0]		GRP3_DLY[1:0]		GRP2_DLY[1:0]		GRP1_DLY[1:0]	
3F	PWRDN DLY2	R/W	—	—	—	—	—	—	RESETBMCU_DLY[1:0]	
40	FREQ CTRL	R/W	SYNCOUT_EN	FSYNC_RANGE	FSS_EN	FSS_RANGE	CLK_FREQ[3:0]			
42	PWRON	R/W	—	—	—	PWRON_DBNCF[1:0]		PWRON_RST_EN	TRESET[1:0]	
43	WD CONFIG	R/W	—	—	—	—	WD_DURATION[3:0]			
44	WD CLEAR	R/W1C	—	—	—	—	—	—	—	WD_CLEAR
45	WD EXPIRE	R/W	—	WD_MAX_EXPIRE[2:0]			—	WD_EXPIRE_CNT[2:0]		
46	WD COUNTER	R/W	WD_MAX_CNT [3:0]				WD_EVENT_CNT [3:0]			
47	FAULT COUNTER	R/W	FAULT_MAX_CNT[3:0]				FAULT_CNT [3:0]			
48	FSAFE COUNTER	R/W	—	—	—	—	FS_CNT [3:0]			
49	FAULT TIMERS	R/W	—	—	—	—	TIMER_FAULT[3:0]			
4A	AMUX	R/W	—	—	AMUX_EN	AMUX_SEL [4:0]				
4D	SW1 CONFIG1	R/W	SW1_UV_BYPASS	SW1_OV_BYPASS	SW1_ILIM_BYPASS	SW1_UV_STATE	SW1_OV_STATE	SW1_ILIM_STATE	SW1_WDBYPASS	SW1_PG_EN
4E	SW1 CONFIG2	R/W	SW1_FLT_REN	SW1DVS_RAMP[1:0]		SW1ILIM[1:0]		SW1PHASE[2:0]		
4F	SW1 PWRUP	R/W	SW1_SEQ[7:0]							
50	SW1 MODE	R/W	—	—	SW1_PDGRP[1:0]	SW1_STBY_MODE[1:0]		SW1_RUN_MODE[1:0]		
51	SW1 RUN VOLT	R/W	VSW1_RUN[7:0]							
52	SW1 STBY VOLT	R/W	VSW1_STBY[7:0]							
55	SW2 CONFIG1	R/W	SW2_UV_BYPASS	SW2_OV_BYPASS	SW2_ILIM_BYPASS	SW2_UV_STATE	SW2_OV_STATE	SW2_ILIM_STATE	SW2_WDBYPASS	SW2_PG_EN
56	SW2 CONFIG2	R/W	SW2_FLT_REN	SW2DVS_RAMP[1:0]		SW2ILIM[1:0]		SW2PHASE[2:0]		
57	SW2 PWRUP	R/W	SW2_SEQ[7:0]							
58	SW2 MODE1	R/W	—	—	SW2_PDGRP[1:0]	SW2_STBY_MODE[1:0]		SW2_RUN_MODE[1:0]		
59	SW2 RUN VOLT	R/W	VSW2_RUN[7:0]							
5A	SW2 STBY VOLT	R/W	VSW2_STBY[7:0]							

7-channel power management integrated circuit for high performance applications

AD DR	Register Name	R/W	BIT7	BIT6	BIT5	BIT4	BIT3	BIT2	BIT1	BIT0	
5D	SW3 CONFIG1	R/W	SW3_UV_BYPASS	SW3_OV_BYPASS	SW3_ILIM_BYPASS	SW3_UV_STATE	SW3_OV_STATE	SW3_ILIM_STATE	SW3_WDBYPASS	SW3_PG_EN	
5E	SW3 CONFIG2	R/W	SW3_FLT_REN	SW3DVS_RAMP[1:0]		SW3ILIM[1:0]		SW3PHASE[2:0]			
5F	SW3 PWRUP	R/W	SW3_SEQ[7:0]								
60	SW3 MODE1	R/W	—	SW3_VTTEN	SW3_PDGRP[1:0]		SW3_STBY_MODE[1:0]		SW3_RUN_MODE[1:0]		
61	SW3 RUN VOLT	R/W	VSW3_RUN[7:0]								
62	SW3 STBY VOLT	R/W	VSW3_STBY[7:0]								
65	SW4 CONFIG1	R/W	SW4_UV_BYPASS	SW4_OV_BYPASS	SW4_ILIM_BYPASS	SW4_UV_STATE	SW4_OV_STATE	SW4_ILIM_STATE	SW4_WDBYPASS	SW4_PG_EN	
66	SW4 CONFIG2	R/W	SW4_FLT_REN	SW4DVS_RAMP[1:0]		SW4ILIM[1:0]		SW4PHASE[2:0]			
67	SW4 PWRUP	R/W	SW4_SEQ[7:0]								
68	SW4 MODE1	R/W	—	—	SW4_PDGRP[1:0]		SW4_STBY_MODE[1:0]		SW4_RUN_MODE[1:0]		
69	SW4 RUN VOLT	R/W	VSW4_RUN[7:0]								
6A	SW4 STBY VOLT	R/W	VSW4_STBY[7:0]								
7D	SW5CONFIG1	R/W	SW5_UV_BYPASS	SW5_OV_BYPASS	SW5_ILIM_BYPASS	SW5_UV_STATE	SW5_OV_STATE	SW5_ILIM_STATE	SW5_WDBYPASS	SW5_PG_EN	
7E	SW5 CONFIG2	R/W	SW5_FLT_REN	—	—	SW5ILIM[1:0]		SW5PHASE[2:0]			
7F	SW5 PWRUP	R/W	SW5_SEQ[7:0]								
80	SW5 MODE1	R/W	—	—	SW5_PDGRP[1:0]		SW5_STBY_MODE[1:0]		SW5_RUN_MODE[1:0]		
81	SW5 RUN VOLT	R/W	—	—	—	VSW5_RUN[4:0]					
85	LDO1 CONFIG1	R/W	LDO1_UV_BYPASS	LDO1_OV_BYPASS	LDO1_ILIM_BYPASS	LDO1_UV_STATE	LDO1_OV_STATE	LDO1_ILIM_STATE	LDO1_WDBYPASS	LDO1_PG_EN	
86	LDO1 CONFIG2	R/W	LDO1_FLT_REN	LDO1_PDGRP[1:0]		—	—	—	LDO1_RUN_EN	LDO1_STBY_EN	
87	LDO1 PWRUP	R/W	LDO1_SEQ[7:0]								
88	LDO1 RUN VOLT	R/W	—	—	—	—	VLDO1_RUN[3:0]				
89	LDO1 STBY VOLT	R/W	—	—	—	—	VLDO1_STBY[3:0]				
8B	LDO2 CONFIG1	R/W	LDO2_UV_BYPASS	LDO2_OV_BYPASS	LDO2_ILIM_BYPASS	LDO2_UV_STATE	LDO2_OV_STATE	LDO2_ILIM_STATE	LDO2_WDBYPASS	LDO2_PG_EN	
8C	LDO2 CONFIG2	R/W	LDO2_FLT_REN	LDO2_PDGRP[1:0]		LDO2HW_EN	VSELECT_EN	—	LDO2_RUN_EN	LDO2_STBY_EN	
8D	LDO2 PWRUP	R/W	LDO2_SEQ[7:0]								
8E	LDO2 RUN VOLT	R/W	—	—	—	—	VLDO2_RUN[3:0]				
8F	LDO2 STBY VOLT	R/W	—	—	—	—	VLDO2_STBY[3:0]				
9D	VSNVS CONFIG1	R/W	—	—	—	—	VSNVS2VOLT [1:0]		VSNVS1VOLT [1:0]		
9F	PAGE SELECT	R/TW	—	—	—	—	—	PAGE[2:0]			

16.2 PF7100 ASIL B OTP mirror register map (page 1)

Reset types	
OFF_OTP	Register loads the OTP mirror register values during power up
OTP	Register available in OTP bank only, reset from fuses when VIN crosses UVDET threshold
VSNVS	Reset when BOS has no valid input. VIN < UVDET

ADDR	Register name	BIT7	BIT6	BIT5	BIT4	BIT3	BIT2	BIT1	BIT0
A0	OTP FSOB SELECT	—	—	—	OTP_FSOB_ASS_EN	OTP_FSOB_SOFTFAULT	OTP_FSOB_WDI	OTP_FSOB_WDC	OTP_FSOB_HARDFAULT
A1	OTP I2C	—	—	—	OTP_I2C_SECURE_EN	OTP_I2C_CRC_EN	OTP_I2C_ADD[2:0]		
A2	OTP CTRL1	—	—	OTP_EWARN_TIME[1:0]		OTP_FS_BYPASS	OTP_STANDBYINV	OTP_PG_ACTIVE	OTP_PG_CHECK

7-channel power management integrated circuit for high performance applications

ADDR	Register name	BIT7	BIT6	BIT5	BIT4	BIT3	BIT2	BIT1	BIT0
A3	OTP CTRL2	OTP_FSS_EN	OTP_FSS_RANGE	—	OTP_XFAILB_EN	OTP_VIN_OVLO_SDWN	OTP_VIN_OVLO_EN	OTP_VIN_OVLO_DBNC[1:0]	
A4	OTP CTRL3	OTP_VTT_PDOWN	OTP_SW3_VTTEN	—	—	OTP_SW4ONFIG[1:0]		OTP_SW1CONFIG[1:0]	
A5	OTP FREQ CTRL	OTP_SW_MODE	OTP_SYNCIN_EN	OTP_SYNCOUT_EN	OTP_FSYNC_RANGE	OTP_CLK_FREQ[3:0]			
A6	OTP SW RAMP	OTP_SW4DVS_RAMP[1:0]		OTP_SW3DVS_RAMP[1:0]		OTP_SW2DVS_RAMP[1:0]		OTP_SW1DVS_RAMP[1:0]	
A7	OTP PWRON	—	—	OTP_PWRON_MODE	OTP_PWRON_DBNC[1:0]		OTP_PWRON_RST_EN	OTP_TRESET[1:0]	
A8	OTP WD CONFIG	—	—	OTP_WDI_MODE	OTP_WDI_INV	OTP_WD_EN	OTP_WD_STBY_EN	OTP_WDI_STBY_ACTIVE	OTP_WDWINDOW
A9	OTP WD EXPIRE	—	—	—	—	—	OTP_WD_MAX_EXPIRE[2:0]		
AA	OTP WD COUNTER	OTP_WD_DURATION[3:0]				OTP_WD_MAX_CNT [3:0]			
AB	OTP FAULT COUNTERS	OTP_FS_MAX_CNT[3:0]				OTP_FAULT_MAX_CNT[3:0]			
AC	OTP FAULT TIMERS	—	OTP_FS_OK_TIMER[2:0]			OTP_TIMER_FAULT[3:0]			
AD	OTP PWRDN DLY1	OTP_GRP4_DLY[1:0]		OTP_GRP3_DLY[1:0]		OTP_GRP2_DLY[1:0]		OTP_GRP1_DLY[1:0]	
AE	OTP PWRDN DLY2	OTP_PD_SEQ_DLY[1:0]		—	—	—	—	OTP_RESETBMCU_DLY[1:0]	
AF	OTP PWRUP CTRL	—	OTP_PWRDN_MODE	OTP_PGOOD_PDGRP[1:0]		OTP_RESETBMCU_PDGRP[1:0]			OTP_SEQ_TBASE[1:0]
B0	OTP RESETBMCU PWRUP	OTP_RESETBMCU_SEQ[7:0]							
B1	OTP PGOOD PWRUP	OTP_PGOOD_SEQ[7:0]							
B2	OTP SW1 VOLT	OTP_VSW1[7:0]							
B3	OTP SW1 PWRUP	OTP_SW1_SEQ[7:0]							
B4	OTP SW1 CONFIG1	OTP_SW1UV_TH[1:0]		OTP_SW1OV_TH[1:0]		OTP_SW1_PDGRP[1:0]		OTP_SW1ILIM[1:0]	
B5	OTP SW1 CONFIG2	OTP_SW1_LSELECT[1:0]		OTP_SW1PHASE[2:0]			—	OTP_SW1_PG_EN	OTP_SW1_WDBYPASS
B6	OTP SW2 VOLT	OTP_VSW2[7:0]							
B7	OTP SW2 PWRUP	OTP_SW2_SEQ[7:0]							
B8	OTP SW2 CONFIG1	OTP_SW2UV_TH[1:0]		OTP_SW2OV_TH[1:0]		OTP_SW2_PDGRP[1:0]		OTP_SW2ILIM[1:0]	
B9	OTP SW2 CONFIG2	OTP_SW2_LSELECT[1:0]		OTP_SW2PHASE[2:0]			—	OTP_SW2_PG_EN	OTP_SW2_WDBYPASS
BA	OTP SW3 VOLT	OTP_VSW3[7:0]							
BB	OTP SW3 PWRUP	OTP_SW3_SEQ[7:0]							
BC	OTP SW3 CONFIG1	OTP_SW3UV_TH[1:0]		OTP_SW3OV_TH[1:0]		OTP_SW3_PDGRP[1:0]		OTP_SW3ILIM[1:0]	
BD	OTP SW3 CONFIG2	OTP_SW3_LSELECT[1:0]		OTP_SW3PHASE[2:0]			—	OTP_SW3_PG_EN	OTP_SW3_WDBYPASS
BE	OTP SW4 VOLT	OTP_VSW4[7:0]							
BF	OTP SW4 PWRUP	OTP_SW4_SEQ[7:0]							
C0	OTP SW4 CONFIG1	OTP_SW4UV_TH[1:0]		OTP_SW4OV_TH[1:0]		OTP_SW4_PDGRP[1:0]		OTP_SW4ILIM[1:0]	
C1	OTP SW4 CONFIG2	OTP_SW4_LSELECT[1:0]		OTP_SW4PHASE[2:0]			—	OTP_SW4_PG_EN	OTP_SW4_WDBYPASS
CA	OTP SW5 VOLT	—	—	—	OTP_VSW5[4:0]				
CB	OTP SW5 PWRUP	OTP_SW5_SEQ[7:0]							
CC	OTP SW5 CONFIG1	OTP_SW5UV_TH[1:0]		OTP_SW5OV_TH[1:0]		OTP_SW5_PDGRP[1:0]		OTP_SW5ILIM[1:0]	
CD	OTP SW5 CONFIG2	OTP_SW5_LSELECT[1:0]		OTP_SW5PHASE[2:0]			—	OTP_SW5_PG_EN	OTP_SW5_WDBYPASS

7-channel power management integrated circuit for high performance applications

ADDR	Register name	BIT7	BIT6	BIT5	BIT4	BIT3	BIT2	BIT1	BIT0
CE	OTP LDO1 VOLT	OTP_LDO1UV_TH[1:0]		OTP_LDO1OV_TH[1:0]		OTP_VLDO1[3:0]			
CF	OTP LDO1 PWRUP	OTP_LDO1_SEQ[7:0]							
D0	OTP LDO1 CONFIG	OTP_LDO1_PDGRP[1:0]		—	—	—	OTP_LDO1_PG_EN	OTP_LDO1_WDBYPASS	OTP_LDO1LS
D1	OTP LDO2 VOLT	OTP_LDO2UV_TH[1:0]		OTP_LDO2OV_TH[1:0]		OTP_VLDO2[3:0]			
D2	OTP LDO2 PWRUP	OTP_LDO2_SEQ[7:0]							
D3	OTP LDO2 CONFIG	OTP_LDO2_PDGRP[1:0]		OTP_VSELECT_EN	OTP_LDO2HW_EN	—	OTP_LDO2_PG_EN	OTP_LDO2_WDBYPASS	OTP_LDO2LS
DA	OTP VSNVS CONFIG	—	—	—	—	OTP_VSNVS2VOLT [1:0]		OTP_VSNVS1VOLT [1:0]	
DB	OTP_OV_BYPASS1	—	OTP_SW5_OVBYPASS	—	—	OTP_SW4_OVBYPASS	OTP_SW3_OVBYPASS	OTP_SW2_OVBYPASS	OTP_SW1_OVBYPASS
DC	OTP_OV_BYPASS2	—	—	—	—	—	—	OTP_LDO2_OVBYPASS	OTP_LDO1_OVBYPASS
DD	OTP_UV_BYPASS1	—	OTP_SW5_UVBYPASS	—	—	OTP_SW4_UVBYPASS	OTP_SW3_UVBYPASS	OTP_SW2_UVBYPASS	OTP_SW1_UVBYPASS
DE	OTP_UV_BYPASS2	—	—	—	—	—	—	OTP_LDO2_UVBYPASS	OTP_LDO1_UVBYPASS
DF	OTP_ILIM_BYPASS1	—	OTP_SW5_ILIMBYPASS	—	—	OTP_SW4_ILIMBYPASS	OTP_SW3_ILIMBYPASS	OTP_SW2_ILIMBYPASS	OTP_SW1_ILIMBYPASS
E0	OTP_ILIM_BYPASS2	—	—	—	—	—	—	OTP_LDO2_ILIMBYPASS	OTP_LDO1_ILIMBYPASS
E1	OTP_PROG_IDH	—	—	—	—	OTP_PROG_ID11	OTP_PROG_ID10	OTP_PROG_ID9	OTP_PROG_ID8
E2	OTP_PROG_IDL	OTP_PROG_ID7	OTP_PROG_ID6	OTP_PROG_ID5	OTP_PROG_ID4	OTP_PROG_ID3	OTP_PROG_ID2	OTP_PROG_ID1	OTP_PROG_ID0
E3	OTP_DEBUG1	—	—	—	—	—	—	—	OTP_BGMON_BYPASS

16.3 PF7100 QM functional register map

RESET SIGNALS		R/W types	
UVDET	Reset when VIN crosses UVDET threshold	R	Read only
OFF_OTP	Bits are loaded with OTP values (mirror register)	R/W	Read and Write
OFF_TOGGLE	Reset when device goes to OFF mode	RW1C	Read, Write a 1 to clear
SC	Self-clear after write	R/SW	Read/Secure Write
NO_VSNVS	Reset when BOS has no valid input VIN < UVDET	R/TW	Read/Write on TBB only

AD DR	Register Name	R/W	BIT7	BIT6	BIT5	BIT4	BIT3	BIT2	BIT1	BIT0	
00	DEVICE ID	R	DEVICE_FAM[3:0]				DEVICE_ID[3:0]				
01	REV ID	R	FULL_LAYER_REV[3:0]				METAL_LAYER_REV[3:0]				
02	EMREV	R	PROG_IDH[11-8]				—	EMREV[2:0]			
03	PROG ID	R	PROG_IDL[7:0]								
04	INT STATUS1	RW1C	SDWN_I	FREQ_RDY_I	CRC_I	PWRUP_I	PWRDN_I	XINTB_I	FSOB_I	VIN_OVLO_I	
05	INT MASK1	R/W	SDWN_M	FREQ_RDY_M	CRC_M	PWRUP_M	PWRDN_M	XINTB_M	FSOB_M	VIN_OVLO_M	
06	INT SENSE1	R	—	—	—	—	—	XINTB_S	FSOB_S	VIN_OVLO_S	
07	THERM INT	RW1C	WDI_I	FSYNC_FLT_I	THERM_155_I	THERM_140_I	THERM_125_I	THERM_110_I	THERM_95_I	THERM_80_I	
08	THERM MASK	R/W	WDI_M	FSYNC_FLT_M	THERM_155_M	THERM_140_M	THERM_125_M	THERM_110_M	THERM_95_M	THERM_80_M	
09	THERM SENSE	R	WDI_S	FSYNC_FLT_S	THERM_155_S	THERM_140_S	THERM_125_S	THERM_110_S	THERM_95_S	THERM_80_S	
0A	SW MODE INT	RW1C	—	SW5_MODE_I	—	—	SW4_MODE_I	SW3_MODE_I	SW2_MODE_I	SW1_MODE_I	
0B	SW MODE MASK	R/W	—	SW5_MODE_M	—	—	SW4_MODE_M	SW3_MODE_M	SW2_MODE_M	SW1_MODE_M	
12	SW ILIM INT	RW1C	—	SW5_ILIM_I	—	—	SW4_ILIM_I	SW3_ILIM_I	SW2_ILIM_I	SW1_ILIM_I	
13	SW ILIM MASK	R/W	—	SW5_ILIM_M	—	—	SW4_ILIM_M	SW3_ILIM_M	SW2_ILIM_M	SW1_ILIM_M	
14	SW ILIM SENSE	R	—	SW5_ILIM_S	—	—	SW4_ILIM_S	SW3_ILIM_S	SW2_ILIM_S	SW1_ILIM_S	
15	LDO ILIM INT	RW1C	—	—	—	—	—	—	LDO2_ILIM_I	LDO1_ILIM_I	
16	LDO ILIM MASK	R/W	—	—	—	—	—	—	LDO2_ILIM_M	LDO1_ILIM_M	
17	LDO ILIM SENSE	R	—	—	—	—	—	—	LDO2_ILIM_S	LDO1_ILIM_S	
18	SW UV INT	RW1C	—	SW5_UV_I	—	—	SW4_UV_I	SW3_UV_I	SW2_UV_I	SW1_UV_I	
19	SW UV MASK	R/W	—	SW5_UV_M	—	—	SW4_UV_M	SW3_UV_M	SW2_UV_M	SW1_UV_M	
1A	SW UV SENSE	R	—	SW5_UV_S	—	—	SW4_UV_S	SW3_UV_S	SW2_UV_S	SW1_UV_S	
1B	SW OV INT	RW1C	—	SW5_OV_I	—	—	SW4_OV_I	SW3_OV_I	SW2_OV_I	SW1_OV_I	
1C	SW OV MASK	R/W	—	SW5_OV_M	—	—	SW4_OV_M	SW3_OV_M	SW2_OV_M	SW1_OV_M	
1D	SW OV SENSE	R	—	SW5_OV_S	—	—	SW4_OV_S	SW3_OV_S	SW2_OV_S	SW1_OV_S	
1E	LDO UV INT	RW1C	—	—	—	—	—	—	LDO2_UV_I	LDO1_UV_I	
1F	LDO UV MASK	R/W	—	—	—	—	—	—	LDO2_UV_M	LDO1_UV_M	
20	LDO UV SENSE	R	—	—	—	—	—	—	LDO2_UV_S	LDO1_UV_S	
21	LDO OV INT	RW1C	—	—	—	—	—	—	LDO2_OV_I	LDO1_OV_I	
22	LDO OV MASK	R/W	—	—	—	—	—	—	LDO2_OV_M	LDO1_OV_M	
23	LDO OV SENSE	R	—	—	—	—	—	—	LDO2_OV_S	LDO1_OV_S	
24	PWRON INT	RW1C	BGMON_I	PWRON_8S_I	PWRON_4S_I	PRON_3S_I	PWRON_2S_I	PWRON_1S_I	PWRON_REL_I	PWRON_PUSH_I	
25	PWRON MASK	R/W	BGMON_M	PWRON_8S_M	PWRON_4S_M	PRON_3S_M	PWRON_2S_M	PWRON_1S_M	PWRON_REL_M	PWRON_PUSH_M	
26	PWRON SENSE	R	BGMON_S	—	—	—	—	—	—	PWRON_S	
27	SYS INT	R	EWARN_I	PWRON_I	OV_I	UV_I	ILIM_I	MODE_I	STATUS2_I	STATUS1_I	
29	HARD FAULT FLAGS	RW1C	—	—	—	—	PU_FAIL	WD_FAIL	REG_FAIL	TSD_FAIL	
2A	FSOB FLAGS	R/SW	—	—	—	—	FSOB_SFAULT_NOK	FSOB_WDI_NOK	FSOB_WDC_NOK	FSOB_HFAULT_NOK	
2B	FSOB SELECT	R/W	—	—	—	—	FSOB_SOFTFAULT	FSOB_WDI	FSOB_WDC	FSOB_HARDFAULT	
30	TEST FLAGS	R/TW	—	—	—	LDO2EN_S	VSELECT_S	—	TRIM_NOK	OTP_NOK	
35	VMONEN1	R/SW	—	SW5VMON_EN	—	—	SW4VMON_EN	SW3VMON_EN	SW2VMON_EN	SW1VMON_EN	

7-channel power management integrated circuit for high performance applications

AD DR	Register Name	R/W	BIT7	BIT6	BIT5	BIT4	BIT3	BIT2	BIT1	BIT0
36	VMONEN2	R/SW	—	—	—	—	—	—	LDO2VMON_EN	LDO1VMON_EN
37	CTRL1	R/SW	VIN_OVLO_EN	VIN_OVLO_SDWN	WDI_MODE	TMP_MON_EN	WD_EN	WD_STBY_EN	WDI_STBY_ACTIVE	—
38	CTRL2	R/W	VIN_OVLO_DBNC[1:0]		—	TMP_MON_AON	LPM_OFF	STANDBYINV	RUN_PG_GPO	STBY_PG_GPO
39	CTRL3	R/W	OV_DB[1:0]		UV_DB[1:0]		—	—	PMIC_OFF	INTB_TEST
3A	PWRUP CTRL	R/W	—	PWRDWN_MODE	PGOOD_PDGRP[1:0]		RESETMCU_PDGRP[1:0]		SEQ_TBASE[1:0]	
3C	RESETMCU PWRUP	R/W	RESETMCU_SEQ[7:0]							
3D	PGOOD PWRUP	R/W	PGOOD_SEQ[7:0]							
3E	PWRDN DLY1	R/W	GRP4_DLY[1:0]		GRP3_DLY[1:0]		GRP2_DLY[1:0]		GRP1_DLY[1:0]	
3F	PWRDN DLY2	R/W	—	—	—	—	—	—	RESETMCU_DLY[1:0]	
40	FREQ CTRL	R/W	SYNCOUT_EN	FSYNC_RANGE	FSS_EN	FSS_RANGE	CLK_FREQ[3:0]			
42	PWRON	R/W	—	—	—	PWRON_DBNC [1:0]		PWRON_RST_EN	TRESET[1:0]	
43	WD CONFIG	R/W	—	—	—	—	WD_DURATION[3:0]			
44	WD CLEAR	R/W1C	—	—	—	—	—	—	WD_CLEAR	
45	WD EXPIRE	R/W	—	WD_MAX_EXPIRE[2:0]			—	WD_EXPIRE_CNT[2:0]		
46	WD COUNTER	R/W	WD_MAX_CNT [3:0]			WD_EVENT_CNT [3:0]				
47	FAULT COUNTER	R/W	FAULT_MAX_CNT[3:0]			FAULT_CNT [3:0]				
49	FAULT TIMERS	R/W	—	—	—	—	TIMER_FAULT[3:0]			
4A	AMUX	R/W	—	—	AMUX_EN	AMUX_SEL [4:0]				
4D	SW1 CONFIG1	R/W	SW1_UV_BYPASS	SW1_OV_BYPASS	SW1_ILIM_BYPASS	SW1_UV_STATE	SW1_OV_STATE	SW1_ILIM_STATE	SW1_WDBYPASS	SW1_PG_EN
4E	SW1 CONFIG2	R/W	SW1_FLT_REN	SW1DVS_RAMP[1:0]		SW1ILIM[1:0]		SW1PHASE[2:0]		
4F	SW1 PWRUP	R/W	SW1_SEQ[7:0]							
50	SW1 MODE	R/W	—	—	SW1_PDGRP[1:0]	SW1_STBY_MODE[1:0]		SW1_RUN_MODE[1:0]		
51	SW1 RUN VOLT	R/W	VSW1_RUN[7:0]							
52	SW1 STBY VOLT	R/W	VSW1_STBY[7:0]							
55	SW2 CONFIG1	R/W	SW2_UV_BYPASS	SW2_OV_BYPASS	SW2_ILIM_BYPASS	SW2_UV_STATE	SW2_OV_STATE	SW2_ILIM_STATE	SW2_WDBYPASS	SW2_PG_EN
56	SW2 CONFIG2	R/W	SW2_FLT_REN	SW2DVS_RAMP[1:0]		SW2ILIM[1:0]		SW2PHASE[2:0]		
57	SW2 PWRUP	R/W	SW2_SEQ[7:0]							
58	SW2 MODE1	R/W	—	—	SW2_PDGRP[1:0]		SW2_STBY_MODE[1:0]		SW2_RUN_MODE[1:0]	
59	SW2 RUN VOLT	R/W	VSW2_RUN[7:0]							
5A	SW2 STBY VOLT	R/W	VSW2_STBY[7:0]							
5D	SW3 CONFIG1	R/W	SW3_UV_BYPASS	SW3_OV_BYPASS	SW3_ILIM_BYPASS	SW3_UV_STATE	SW3_OV_STATE	SW3_ILIM_STATE	SW3_WDBYPASS	SW3_PG_EN
5E	SW3 CONFIG2	R/W	SW3_FLT_REN	SW3DVS_RAMP[1:0]		SW3ILIM[1:0]		SW3PHASE[2:0]		
5F	SW3 PWRUP	R/W	SW3_SEQ[7:0]							
60	SW3 MODE1	R/W	—	SW3_VTTEN	SW3_PDGRP[1:0]		SW3_STBY_MODE[1:0]		SW3_RUN_MODE[1:0]	
61	SW3 RUN VOLT	R/W	VSW3_RUN[7:0]							
62	SW3 STBY VOLT	R/W	VSW3_STBY[7:0]							
65	SW4 CONFIG1	R/W	SW4_UV_BYPASS	SW4_OV_BYPASS	SW4_ILIM_BYPASS	SW4_UV_STATE	SW4_OV_STATE	SW4_ILIM_STATE	SW4_WDBYPASS	SW4_PG_EN
66	SW4 CONFIG2	R/W	SW4_FLT_REN	SW4DVS_RAMP[1:0]		SW4ILIM[1:0]		SW4PHASE[2:0]		
67	SW4 PWRUP	R/W	SW4_SEQ[7:0]							
68	SW4 MODE1	R/W	—	—	SW4_PDGRP[1:0]		SW4_STBY_MODE[1:0]		SW4_RUN_MODE[1:0]	
69	SW4 RUN VOLT	R/W	VSW4_RUN[7:0]							
6A	SW4 STBY VOLT	R/W	VSW4_STBY[7:0]							
7D	SW5 CONFIG1	R/W	SW5_UV_BYPASS	SW5_OV_BYPASS	SW5_ILIM_BYPASS	SW5_UV_STATE	SW5_OV_STATE	SW5_ILIM_STATE	SW5_WDBYPASS	SW5_PG_EN
7E	SW5 CONFIG2	R/W	SW5_FLT_REN	—	—	SW5ILIM[1:0]		SW5PHASE[2:0]		
7F	SW5 PWRUP	R/W	SW5_SEQ[7:0]							
80	SW5 MODE1	R/W	—	—	SW5_PDGRP[1:0]		SW5_STBY_MODE[1:0]		SW5_RUN_MODE[1:0]	
81	SW5 RUN VOLT	R/W	—	—	—	VSW5[4:0]				

7-channel power management integrated circuit for high performance applications

AD DR	Register Name	R/W	BIT7	BIT6	BIT5	BIT4	BIT3	BIT2	BIT1	BIT0
85	LDO1 CONFIG1	R/W	LDO1_UV_BYPASS	LDO1_OV_BYPASS	LDO1_ILIM_BYPASS	LDO1_UV_STATE	LDO1_OV_STATE	LDO1_ILIM_STATE	LDO1_WDBYPASS	LDO1_PG_EN
86	LDO1 CONFIG2	R/W	LDO1_FLT_REN	LDO1_PDGRP[1:0]		—	—	—	LDO1_RUN_EN	LDO1_STBY_EN
87	LDO1 PWRUP	R/W	LDO1_SEQ[7:0]							
88	LDO1 RUN VOLT	R/W	—	—	—	—	VLDO1_RUN[3:0]			
89	LDO1 STBY VOLT	R/W	—	—	—	—	VLDO1_STBY[3:0]			
8B	LDO2 CONFIG1	R/W	LDO2_UV_BYPASS	LDO2_OV_BYPASS	LDO2_ILIM_BYPASS	LDO2_UV_STATE	LDO2_OV_STATE	LDO2_ILIM_STATE	LDO2_WDBYPASS	LDO2_PG_EN
8C	LDO2 CONFIG2	R/W	LDO2_FLT_REN	LDO2_PDGRP[1:0]		LDO2HW_EN	VSELECT_EN	—	LDO2_RUN_EN	LDO2_STBY_EN
8D	LDO2 PWRUP	R/W	LDO2_SEQ[7:0]							
8E	LDO2 RUN VOLT	R/W	—	—	—	—	VLDO2_RUN[3:0]			
8F	LDO2 STBY VOLT	R/W	—	—	—	—	VLDO2_STBY[3:0]			
9D	VSNVS CONFIG1	R/W	—	—	—	—	VSNVS2VOLT [1:0]		VSNVS1VOLT [1:0]	
9F	PAGE SELECT	R/TW	—	—	—	—	—	PAGE[2:0]		

16.4 PF7100 QM OTP mirror register map (page 1)

Reset types

OFF_OTP	Register loads the OTP mirror register values during power up
OTP	Register available in OTP bank only, reset from fuses when VIN crosses UVDET threshold
VSNVS	Reset when BOS has no valid input. VIN < UVDET

AD DR	Register name	BIT7	BIT6	BIT5	BIT4	BIT3	BIT2	BIT1	BIT0	
A0	OTP FSOB SELECT	—	—	—	—	OTP_FSOB_SOFTFAULT	OTP_FSOB_WDI	OTP_FSOB_WDC	OTP_FSOB_HARDFAULT	
A1	OTP I2C	—	—	—	—	OTP_I2C_CRC_EN		OTP_I2C_ADD[2:0]		
A2	OTP CTRL1	—	—	OTP_EWARN_TIME[1:0]		—	OTP_STANDBYINV	OTP_PG_ACTIVE	OTP_PG_CHECK	
A3	OTP CTRL2	OTP_FSS_EN	OTP_FSS_RANGE	—	OTP_XFAILB_EN	OTP_VIN_OVLO_SDWN	OTP_VIN_OVLO_EN	OTP_VIN_OVLO_DBNC[1:0]		
A4	OTP CTRL3	OTP_VTT_PDOWN	OTP_SW3_VTTEN	—	—	OTP_SW4CONFIG[1:0]			OTP_SW1CONFIG[1:0]	
A5	OTP FREQ CTRL	OTP_SW_MODE	OTP_SYNCIN_EN	OTP_SYNCOUT_EN	OTP_FSYNC_RANGE	OTP_CLK_FREQ[3:0]				
A6	OTP SW RAMP	OTP_SW4DVS_RAMP[1:0]		OTP_SW3DVS_RAMP[1:0]		OTP_SW2DVS_RAMP[1:0]		OTP_SW1DVS_RAMP[1:0]		
A7	OTP PWRON	—	—	OTP_PWRON_MODE	OTP_PWRON_DBNC[1:0]		OTP_PWRON_RST_EN	OTP_TRESET[1:0]		
A8	OTP WD CONFIG	—	—	OTP_WDI_MODE	OTP_WDI_INV	OTP_WD_EN	OTP_WD_STBY_EN	OTP_WDI_STBY_ACTIVE	OTP_WDWINDOW	
A9	OTP WD EXPIRE	—	—	—	—	—	OTP_WD_MAX_EXPIRE[2:0]			
AA	OTP WD COUNTER	OTP_WD_DURATION[3:0]					OTP_WD_MAX_CNT [3:0]			
AB	OTP FAULT COUNTERS	—	—	—	—	OTP_FAULT_MAX_CNT[3:0]				
AC	OTP FAULT TIMERS	—	—	—	—	OTP_TIMER_FAULT[3:0]				
AD	OTP PWRDN DLY1	OTP_GRP4_DLY[1:0]		OTP_GRP3_DLY[1:0]		OTP_GRP2_DLY[1:0]		OTP_GRP1_DLY[1:0]		
AE	OTP PWRDN DLY2	OTP_PD_SEQ_DLY[1:0]		—	—	—	—	OTP_RESETBMCU_DLY[1:0]		
AF	OTP PWRUP CTRL	—	OTP_PWRDN_MODE	OTP_PGOOD_PDGRP[1:0]		OTP_RESETBMCU_PDGRP[1:0]		OTP_SEQ_TBASE[1:0]		

7-channel power management integrated circuit for high performance applications

AD DR	Register name	BIT7	BIT6	BIT5	BIT4	BIT3	BIT2	BIT1	BIT0
B0	OTP RESETBMCU PWRUP	OTP_RESETBMCU_SEQ[7:0]							
B1	OTP PGOOD PWRUP	OTP_PGOOD_SEQ[7:0]							
B2	OTP SW1 VOLT	OTP_VSW1[7:0]							
B3	OTP SW1 PWRUP	OTP_SW1_SEQ[7:0]							
B4	OTP SW1 CONFIG1	OTP_SW1UV_TH[1:0]	OTP_SW1OV_TH[1:0]		OTP_SW1_PDGRP[1:0]		OTP_SW1ILIM[1:0]		
B5	OTP SW1 CONFIG2	OTP_SW1_LSELECT[1:0]	OTP_SW1PHASE[2:0]			—	OTP_SW1_PG_EN	OTP_SW1_WDBYPASS	
B6	OTP SW2 VOLT	OTP_VSW2[7:0]							
B7	OTP SW2 PWRUP	OTP_SW2_SEQ[7:0]							
B8	OTP SW2 CONFIG1	OTP_SW2UV_TH[1:0]	OTP_SW2OV_TH[1:0]		OTP_SW2_PDGRP[1:0]		OTP_SW2ILIM[1:0]		
B9	OTP SW2 CONFIG2	OTP_SW2_LSELECT[1:0]	OTP_SW2PHASE[2:0]			—	OTP_SW2_PG_EN	OTP_SW2_WDBYPASS	
BA	OTP SW3 VOLT	OTP_VSW3[7:0]							
BB	OTP SW3 PWRUP	OTP_SW3_SEQ[7:0]							
BC	OTP SW3 CONFIG1	OTP_SW3UV_TH[1:0]	OTP_SW3OV_TH[1:0]		OTP_SW3_PDGRP[1:0]		OTP_SW3ILIM[1:0]		
BD	OTP SW3 CONFIG2	OTP_SW3_LSELECT[1:0]	OTP_SW3PHASE[2:0]			—	OTP_SW3_PG_EN	OTP_SW3_WDBYPASS	
BE	OTP SW4 VOLT	OTP_VSW4[7:0]							
BF	OTP SW4 PWRUP	OTP_SW4_SEQ[7:0]							
C0	OTP SW4 CONFIG1	OTP_SW4UV_TH[1:0]	OTP_SW4OV_TH[1:0]		OTP_SW4_PDGRP[1:0]		OTP_SW4ILIM[1:0]		
C1	OTP SW4 CONFIG2	OTP_SW4_LSELECT[1:0]	OTP_SW4PHASE[2:0]			—	OTP_SW4_PG_EN	OTP_SW4_WDBYPASS	
CA	OTP SW5 VOLT	—	—	—	OTP_VSW5[4:0]				
CB	OTP SW5 PWRUP	OTP_SW5_SEQ[7:0]							
CC	OTP SW5 CONFIG1	OTP_SW5UV_TH[1:0]	OTP_SW5OV_TH[1:0]		OTP_SW5_PDGRP[1:0]		OTP_SW5ILIM[1:0]		
CD	OTP SW5 CONFIG2	OTP_SW5_LSELECT[1:0]	OTP_SW5PHASE[2:0]			—	OTP_SW5_PG_EN	OTP_SW5_WDBYPASS	
CE	OTP LDO1 VOLT	OTP_LDO1UV_TH[1:0]	OTP_LDO1OV_TH[1:0]		OTP_VLDO1[3:0]				
CF	OTP LDO1 PWRUP	OTP_LDO1_SEQ[7:0]							
D0	OTP LDO1 CONFIG	OTP_LDO1_PDGRP[1:0]	—	—	—	OTP_LDO1_PG_EN	OTP_LDO1_WDBYPASS	OTP_LDO1LS	
D1	OTP LDO2 VOLT	OTP_LDO2UV_TH[1:0]	OTP_LDO2OV_TH[1:0]		OTP_VLDO2[3:0]				
D2	OTP LDO2 PWRUP	OTP_LDO2_SEQ[7:0]							
D3	OTP LDO2 CONFIG	OTP_LDO2_PDGRP[1:0]	OTP_VSELECT_EN	OTP_LDO2HW_EN	—	OTP_LDO2_PG_EN	OTP_LDO2_WDBYPASS	OTP_LDO2LS	
DA	OTP VSNVS CONFIG	—	—	—	—	OTP_VSNVS2VOLT [1:0]		OTP_VSNVS1VOLT[1:0]	
DB	OTP_OV_BYPASS1	—	OTP_SW5_OVBYPASS	—	—	OTP_SW4_OVBYPASS	OTP_SW3_OVBYPASS	OTP_SW2_OVBYPASS	OTP_SW1_OVBYPASS
DC	OTP_OV_BYPASS2	—	—	—	—	—	—	OTP_LDO2_OVBYPASS	OTP_LDO1_OVBYPASS
DD	OTP_UV_BYPASS1	—	OTP_SW5_UVBYPASS	—	—	OTP_SW4_UVBYPASS	OTP_SW3_UVBYPASS	OTP_SW2_UVBYPASS	OTP_SW1_UVBYPASS
DE	OTP_UV_BYPASS2	—	—	—	—	—	—	OTP_LDO2_UVBYPASS	OTP_LDO1_UVBYPASS
DF	OTP_ILIM_BYPASS1	—	OTP_SW5_ILIMBYPASS	—	—	OTP_SW4_ILIMBYPASS	OTP_SW3_ILIMBYPASS	OTP_SW2_ILIMBYPASS	OTP_SW1_ILIMBYPASS

AD DR	Register name	BIT7	BIT6	BIT5	BIT4	BIT3	BIT2	BIT1	BIT0
E0	OTP_ILIM_BYPASS2	—	—	—	—	—	—	OTP_LDO2_ILIMBYPASS	OTP_LDO1_ILIMBYPASS
E1	OTP_PROG_IDH	—	—	—	—	OTP_PROG_ID11	OTP_PROG_ID10	OTP_PROG_ID9	OTP_PROG_ID8
E2	OTP_PROG_IDL	OTP_PROG_ID7	OTP_PROG_ID6	OTP_PROG_ID5	OTP_PROG_ID4	OTP_PROG_ID3	OTP_PROG_ID2	OTP_PROG_ID1	OTP_PROG_ID0
E3	OTP_DEBUG1	—	—	—	—	—	—	—	OTP_BGMON_BYPASS

17 OTP/TBB and hardwire default configurations

The PF7100 supports OTP fuse bank configuration and a predefined hardwire configuration to select the default power up configuration via the VDDOTP pin.

The default power up configuration is loaded into the functional I²C registers based on the voltage on VDDOTP pin on register loading.

- If VDDOTP = GND, the device loads the configuration from the OTP mirror registers.
- If VDDOTP = V1P5D, the device loads the configuration from the default hardwire configuration.

When OTP configuration is selected, the register loading occurs in two stages:

- In the first stage, the fuses are loaded in the OTP mirror registers each time VIN crosses the UVDET threshold in the rising edge.
- At the second stage, data from the mirror registers are loaded into the functional I²C registers for device operation.

When VDDOTP = GND, the mirror registers hold the default configuration to be used on a power-on event. The mirror registers can be modified during the TBB mode to test a custom power up configuration and/or burn the configuration into the OTP fuses to generate a customized default power up configuration.

When VDDOTP = V1P5D, the I²C functional register are always loaded from the hardwire configuration each time a default loading is required. Therefore, no TBB operation is possible in this configuration.

In the event of a TRIM/OTP loading failure or a self-test failure, the corresponding fault flag is set and any PWRUP event is ignored until the flags are cleared by writing a 1 during the QPU_OFF state.

The TRIM_NOK, OTP_NOK and STEST_NOK flags can only be written when the TBBEN = V1P5D (in TBB mode). In normal operation, the TRIM_NOK, OTP_NOK and STEST_NOK flags can only be read, but not cleared.

17.1 TBB (Try Before Buy) operation

The PF7100 allows temporary configuration (TBB) to debug or test a customized power up configuration in the system. In order to access the TBB mode, the TBBEN pin should be set high.

In this mode of operation, the device ignores the default value of the LPM_OFF bit and moves into the QPU_Off state, regardless of the result of the self-test. However, the actual result of the self-test is notified by the STEST_NOK flag.

- When the self-test is successful the STEST_NOK flag is set to 0
- When the self-test has failed, the STEST_NOK flag is set to 1

In the TBB mode, the following conditions are valid:

7-channel power management integrated circuit for high performance applications

- I²C communication uses standard communication with no CRC and secure write disabled.
- Default I²C address is 0x08 regardless of the address configured by OTP.
- Watchdog monitoring is disabled (including WDI and internal watchdog timer).
- The PF7100 can communicate through I²C as long as V_{DDIO} is provided to the PMIC externally.

The PAGE[2:0] bits are provided to grant access to the mirror registers and other OTP dedicated bits. When device is in the TBB mode, it can access the mirror registers in the extended register Page 1. With the TBBEN pin pulled low, access to the extended register pages is not allowed.

The mirror registers are preloaded with the values from the OTP configuration. These may be modified to set the proper power up configuration during TBB operation.

If a power up event is present with the TBBEN pin set high, device powers up with the proper configuration but limited functionality.

Limited functionality includes:

- Default I²C address = 0x08
- CRC and secure write disabled
- Watchdog operation/monitoring disable

In order to allow TBB operation with full functionality, the TBBEN pin must be low when the power up event occurs.

The PF7100 can operate normally using the TBB configuration, as long as VIN does not go below the UVDET threshold. If VIN is lost (VIN < UVDET), the mirror register is reset and TBB configuration must be performed again.

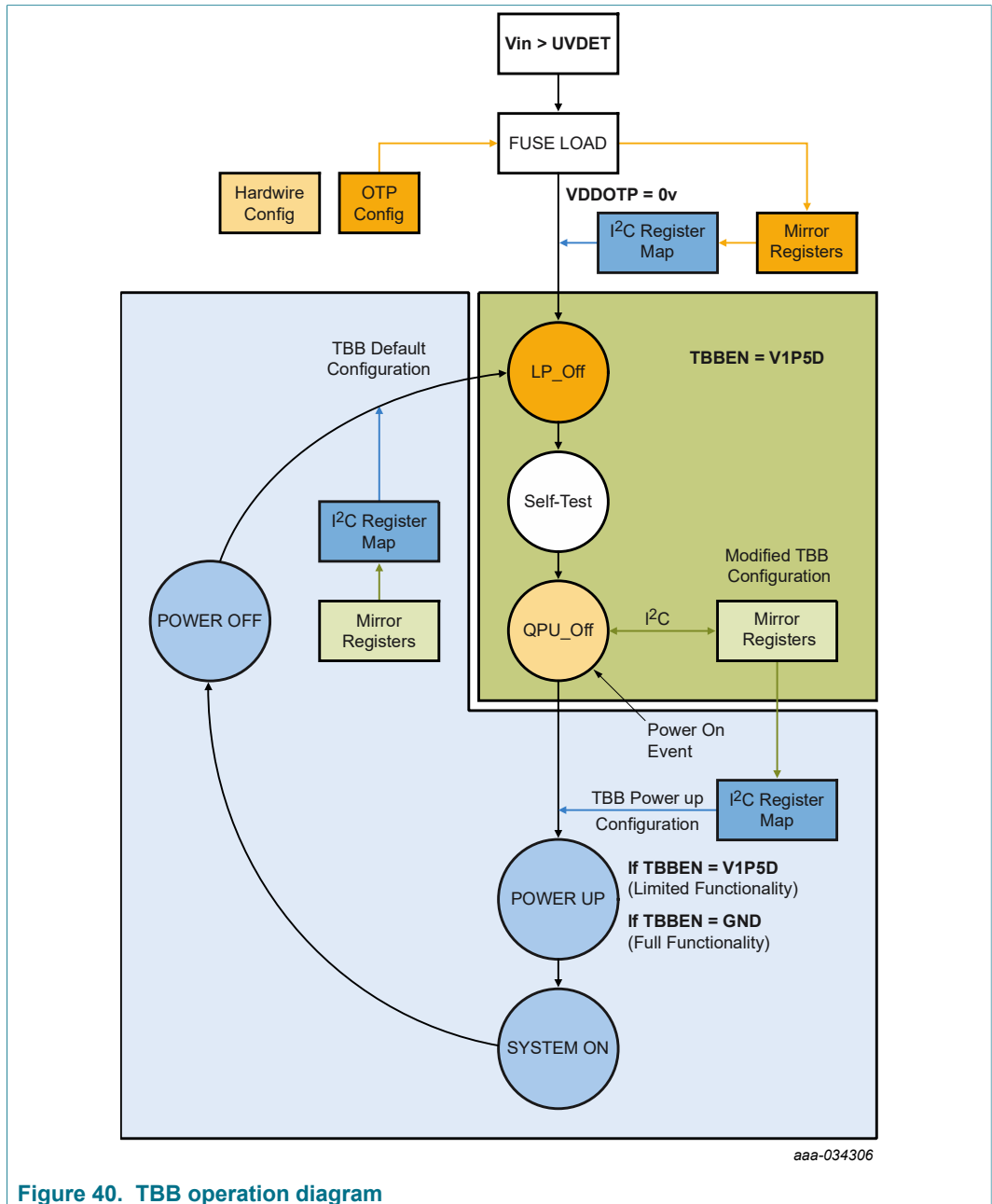

Figure 40. TBB operation diagram

17.2 OTP fuse programming

A permanent OTP configuration is possible by burning the OTP fuses. OTP fuse burning is performed in the TBBEN mode during the QPU_Off state.

Contact your NXP representative for detailed information on OTP fuse programming.

17.3 Default hardwire configuration

If VDDOTP = V1P5D, the device loads the configuration from the default hardwire configuration directly into the corresponding I²C functional registers every time the registers need to be reloaded.

7-channel power management integrated circuit for high performance applications

When using the hardwire configuration, the TRIM values are still loaded from the OTP fuses. In the event of a TRIM loading failure, the corresponding fault flag is set to 1.

When the hardwire configuration is used, the PF7100 does not allow TBB mode operation. When TBBEN = V1P5D, the device enters a debug mode. In this mode of operation, the device ignores the default value of the LPM_OFF bit and moves into the QPU_Off state, regardless of the result of the self-test. However, the actual result of the self-test is notified by the STEST_NOK flag.

- When the self-test is successful, the STEST_NOK flag is set to 0
- When the self-test has failed, the STEST_NOK flag is set to 1

During hardwire configuration, the OTP_NOK flag is always set to 0.

When any of the TRIM_NOK, OTP_NOK or STEST_NOK flags are set, any PWRUP event is ignored until the flags are cleared by writing a 0. These flags can only be written when the system is in the debug mode, (TBBEN = V1P5D). In normal operation, the TRIM_NOK, OTP_NOK and STEST_NOK flags are read only.

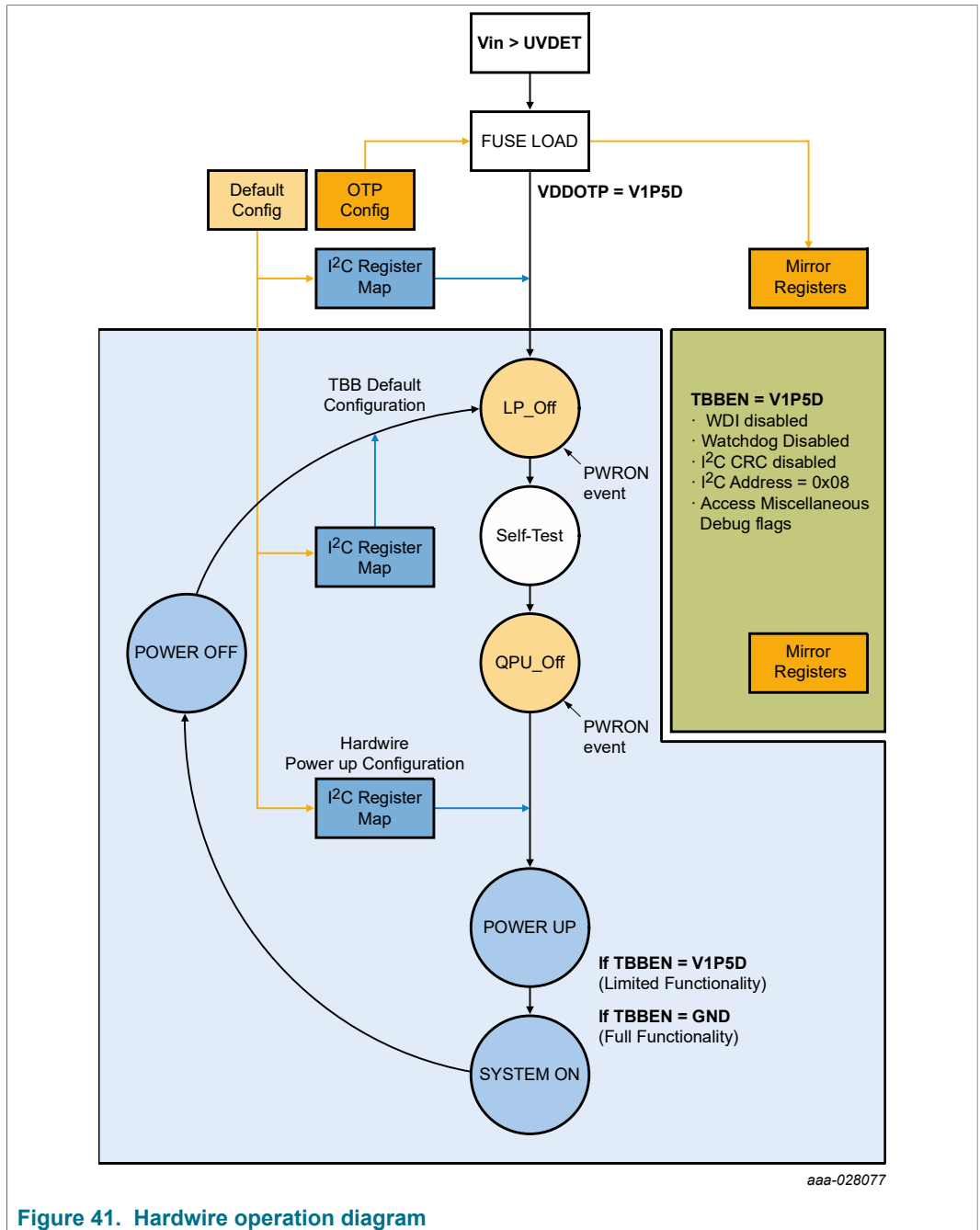

Figure 41. Hardware operation diagram

For simplicity, the default hardware configuration in PF7100 is organized based on the OTP register map as shown in Table 75.

Table 75. Default hardware configuration

ADDR	Register name	BIT7	BIT6	BIT5	BIT4	BIT3	BIT2	BIT1	BIT0	Configuration
A0	OTP FSOB SELECT	0	0	0	0	0	0	0	0	Active Safe State disabled FSOB pin not used
A1	OTP I2C	0	0	0	0	0	0	0	0	Secured I2C disabled I2C CRC disabled I2C address = 0x08
A2	OTP CTRL1	0	0	0	0	0	0	1	0	100us EWARN Fail-safe State enabled STANDBY active high PGOOD indicator PG not Check on power up
A3	OTP CTRL2	0	0	0	0	0	1	0	1	FSS disabled FSS Range = 5 % XFAILB disabled VIN_OVLO shutdown disabled VIN_OVLO enabled VIN_OVLO debounce = 100 μs
A4	OTP CTRL3	0	0	0	0	0	0	0	1	VTT pulldown enabled Single phase: SW5, SW4, SW3 Dual phase: SW1/SW2

7-channel power management integrated circuit for high performance applications

ADDR	Register name	BIT7	BIT6	BIT5	BIT4	BIT3	BIT2	BIT1	BIT0	Configuration
A5	OTP_FREQ_CTRL	0	0	0	0	0	0	0	0	SWx in APS SYNCIN = Disabled SYNCOUT disabled SYNCIN range = 2 MHz to 3 MHz CLK Frequency = 2.5 MHz
A6	OTP_SW_RAMP	0	1	0	1	0	1	0	1	SW1, SW2, SW3, SW4, DVS RAMP, typical 12.5 mV / μ s
A7	OTP_PWRON	0	0	0	0	0	0	0	0	PWRON = Level sensitive
A8	OTP_WD_CONFIG	0	0	0	1	0	0	0	0	WDI generates soft WD reset WDI detect on rising edge WD timer disabled WD Timer in standby disabled WDI detect in standby disabled WD windows = 100 %
A9	OTP_WD_EXPIRE	0	0	0	0	0	1	1	1	Max WD expire count = 8
AA	OTP_WD_COUNTER	1	0	1	0	1	1	1	1	WD duration = 1024 ms Max WD count = 16
AB	OTP_FAULT_COUNTERS	1	1	1	1	1	1	1	1	Fail-safe MAX counter = 16 Regulator fault max counter = 16
AC	OTP_FAULT_TIMERS	0	0	0	0	1	1	1	1	Fail-safe OK timer = 1 minute Regulator fault timer = Disabled
AD	OTP_PWRDN_DLY1	0	0	0	0	0	0	0	0	GRP4 delay = 125 μ s GRP 3 delay = 125 μ s GRP 2 delay = 125 μ s GRP 1 delay = 125 μ s
AE	OTP_PWRDN_DLY2	0	0	0	0	0	0	0	1	No Power Down Delay RESETBMCU delay = 10 μ s
AF	OTP_PWRUP_CTRL	0	0	0	0	0	0	1	0	PD mirror sequence RESETBMCU PD Group2 TBASE = 250 μ s
B0	OTP_RESETBMCU_PWRUP	0	0	0	0	0	1	1	1	RESETBMCU SEQ = Slot 6
B1	OTP_PGOOD_PWRUP	0	0	0	0	0	0	0	0	PGOOD SEQ = OFF
B2	OTP_SW1_VOLT	0	1	1	0	0	0	0	0	Voltage = 1.0 V
B3	OTP_SW1_PWRUP	0	0	0	0	0	0	0	1	SEQ = Slot 0
B4	OTP_SW1_CONFIG1	0	1	0	1	0	0	1	1	UV mon = 7 % OV mon = 7 % SW PD Group4 ILIM typ 4.5 A
B5	OTP_SW1_CONFIG2	0	0	1	1	1	0	1	0	L = 1 μ H Phase = 0° PG = EN WDBYPASS = Disable
B6	OTP_SW2_VOLT	0	1	1	0	0	0	0	0	Voltage = 1.0 V
B7	OTP_SW2_PWRUP	0	0	0	0	0	0	0	1	SEQ = Slot 0
B8	OTP_SW2_CONFIG1	0	1	0	1	0	0	1	1	UV mon = 7 % OV mon = 7 % SW PD Group4 ILIM typ 4.5 A
B9	OTP_SW2_CONFIG2	0	0	0	1	1	0	1	0	L = 1 μ H Phase = 180° PG = EN WDBYPASS = Disable
BA	OTP_SW3_VOLT	0	1	1	1	0	0	0	0	Voltage = 1.1 V
BB	OTP_SW3_PWRUP	0	0	0	0	0	1	0	1	SEQ = Slot 4
BC	OTP_SW3_CONFIG1	0	1	0	1	0	0	1	1	UV mon = 7 % OV mon = 7 % SW PD Group4 ILIM min 4.5 A
BD	OTP_SW3_CONFIG2	0	0	1	1	1	0	1	0	L = 1 μ H Phase = 0° PG = EN WDBYPASS = Disable
BE	OTP_SW4_VOLT	0	1	1	1	0	0	0	0	Voltage = 1.1 V
BF	OTP_SW4_PWRUP	0	0	0	0	0	1	0	1	SEQ = Slot 4
C0	OTP_SW4_CONFIG1	0	1	0	1	0	0	1	1	UV mon = 7 % OV mon = 7 % SW PD Group4 ILIM min 4.5 A
C1	OTP_SW4_CONFIG2	0	0	1	1	1	0	1	0	L = 1 μ H Phase = 0° PG = EN WDBYPASS = Disable
CA	OTP_SW5_VOLT	0	0	0	1	0	1	0	1	Voltage = 3.3 V
CB	OTP_SW5_PWRUP	0	0	0	0	0	0	1	1	SEQ = Slot 2 (TBASE x 2 = 500 μ s)
CC	OTP_SW5_CONFIG1	0	1	0	1	0	0	1	1	UV mon = 7 % OV mon = 7 % SW PD Group4 ILIM min 4.5 A
CD	OTP_SW5_CONFIG2	0	0	1	1	1	0	1	0	L = 1 μ H Phase = 0° PG = EN WDBYPASS = Disable
CE	OTP_LDO1_VOLT	0	1	0	1	0	1	1	1	Voltage = 1.8 V
CF	OTP_LDO1_PWRUP	0	0	0	0	0	0	0	1	SEQ = Slot 0
D0	OTP_LDO1_CONFIG	0	0	0	0	0	1	0	0	LDO PD Group 4 PG = EN WDBYPASS = Disable LDO Mode
D1	OTP_LDO2_VOLT	0	1	0	1	1	1	0	0	Voltage = 3.3 V
D2	OTP_LDO2_PWRUP	0	0	0	0	0	0	1	1	SEQ = Slot 2 (TBASE x 2 = 500 μ s)
D3	OTP_LDO2_CONFIG	0	0	1	1	0	1	0	0	LDO PD Group 4 VSELECT = EN LDO2HW = EN PG = EN WDBYPASS = Disable LDO Mode
DA	OTP_VSNVS_CONFIG	0	0	0	0	1	0	1	0	VSNVS2 = 0.9 V VSNVS1 = 3.0 V
DB	OTP_OV_BYPASS1	0	0	0	0	0	0	0	0	OV Bypass disabled on all SW regulators
DC	OTP_OV_BYPASS2	0	0	0	0	0	0	0	0	OV Bypass disabled on all LDO regulators
DD	OTP_UV_BYPASS1	0	0	0	0	0	0	0	0	UV Bypass disabled on all SW regulators
DE	OTP_UV_BYPASS2	0	0	0	0	0	0	0	0	UV Bypass disabled on all LDO regulators
DF	OTP_ILIM_BYPASS1	0	0	0	0	0	0	0	0	ILIM Bypass disabled on all SW regulators
E0	OTP_ILIM_BYPASS2	0	0	0	0	0	0	0	0	ILIM Bypass disabled on all LDO regulators
E1	OTP_PROG_IDH	0	0	0	0	1	1	1	1	Program ID High Byte = 0x0F
E2	OTP_PROG_IDL	1	1	1	1	1	1	1	1	Program ID Low Byte = 0xFF

18 Functional safety

18.1 System safety strategy

The PF7100 ASIL B device is defined in a context of safety and shall provide a set of features to achieve the safety goals on such context. It provides a flexible yet complete safety architecture to comply with ASIL B systems providing full programmability to enable or disable features to address the safety goal. This architecture includes protective mechanisms to avoid unwanted modification on the respective safety features, as required by the system.

The following are features considered to be critical for the functional safety strategy:

- Internal watchdog timer
- External watchdog monitoring input (WDI)
- Fail-safe output (FSOB)
- Output voltage monitoring with dedicated band gap reference
- Protected I²C protocol with CRC verification
- Input overvoltage protection
- Analog built-in self-test (ABIST)

18.2 Output voltage monitoring with dedicated band gap reference

For the type 2 buck regulator and LDOs, the OV/UV monitors operate from a dedicated band gap reference for voltage monitoring.

For the type 1 buck regulators, the OV/UV monitor operates from the same reference as the regulator. To ensure the integrity of the type 1 buck regulators, a comparison between the regulator band gap and the monitoring band gap is performed. A 4 % to 12 % difference between the two band gaps is an indicator of a potential regulation or monitoring fault and is considered as a critical issue. Therefore, the device prevents the switching regulators from powering up.

On a PF7100 ASIL B device, if a band gap error is detected during a power up event, the self-test fails and prevents the device from powering up regardless of the value of the OTP_BGMON_BYPASS bit.

During system-on states if a drift between the two band gaps is detected:

- When OTP_BGMON_BYPASS = 0, the power stage of the voltage regulators is shutdown.
- When OTP_BGMON_BYPASS = 1, the band gap monitor only sends an interrupt to the system to announce the band gap failure.

The BGMON_I is asserted when a band gap failure occurs, provided it is not masked.

The BGMON_S bit is set to 0 when the band gaps are within range, and set to 1 when the band gaps are out of range.

18.3 ABIST verification

The PF7100 ASIL B device implements an ABIST verification of all output voltage monitors. The ABIST verification on the output voltage monitoring behaves as follows:

- Device test the OV comparators for each individual SWx and LDOx supply during the self-test routine.

7-channel power management integrated circuit for high performance applications

- Device test the UV comparators for each individual SWx and LDOx supply during the self-test routine.
- During the ABIST verification, it is required to ensure the corresponding OV/UV comparators are able to toggle, which in turn is a sign of the integrity of these functions.
- A warning bit is set on the I²C register map, if any of the comparators is not able to toggle.
 - The ABIST_OV1 register contains the AB_SWx_OV bits for all external regulators.
 - The ABIST_OV2 register contains the AB_LDOx_OV bits for all external regulators.
 - The ABIST_UV1 register contains the AB_SWx_UV bits for all external regulators.
 - The ABIST_UV2 register contains the AB_LDOx_UV bits for all external regulators.
- The ABIST registers are cleared or overwritten each time the ABIST check is performed.
- The ABIST registers are part of the secure registers and require an I²C secure write to be cleared, if this feature is enabled.

Once ABIST check is performed, the PF7100 can proceed with the power up sequence and the MCU should be able to request the value of these registers and learn if ABIST failed for any of the voltage monitors.

The AB_RUN bit is provided to perform an ABIST verification on demand.

When the AB_RUN bit is set to 1, the control logic performs an ABIST verification on all OV/UV monitoring circuits. When the ABIST verification is finished, the AB_RUN bit self-clear to 0 and a new ABIST verification can be commanded as needed

When the Secure Write feature is enabled, the system must perform a secure write sequence in order to start an ABIST verification on demand.

When the PF7100 performs an ABIST verification on demand, the OV/UV fault monitoring is blanked for a maximum period of 200us. During this time, the system must ensure it is in a safe state, or it is safe to perform this action without violating the safety goals of the system.

If a failure on the OV/UV monitor is detected during the ABIST on-demand request, the PMIC asserts the corresponding ABIST flags. The system is responsible to perform a diagnostic check after each ABIST verification to ensure it places the system in Safe state if an ABIST fault is detected.

19 IC level quiescent current requirements

Table 76. Quiescent current requirements

All parameters are specified at $T_A = -40\text{ °C}$ to 125 °C for AEC-Q100 grade 1 device, all parameters are specified at $T_A = -40\text{ °C}$ to 105 °C for AEC-Q100 grade 2 device, unless otherwise noted. Typical values are characterized at $V_{IN} = 5.0\text{ V}$ and $T_A = 25\text{ °C}$, unless otherwise noted.

Symbol	Parameter	Min	Typ	Max	Unit
I _{LPOFF}	LP_Off state LPM_OFF = 0 VIN > UVDET VSNVSx = On	—	40	150	μA
I _{QPUOFF}	QPU_Off LPM_OFF = 1 System ready to power on	—	750	1000	μA

Symbol	Parameter	Min	Typ	Max	Unit
I _{SYSON}	System on core current Run or standby and all regulators disabled AMUX disabled	—	750	1000	μA
I _{FSAFE}	Fail-safe mode VIN > UVDET VSNVSx = On	—	40	150	μA

20 Typical applications

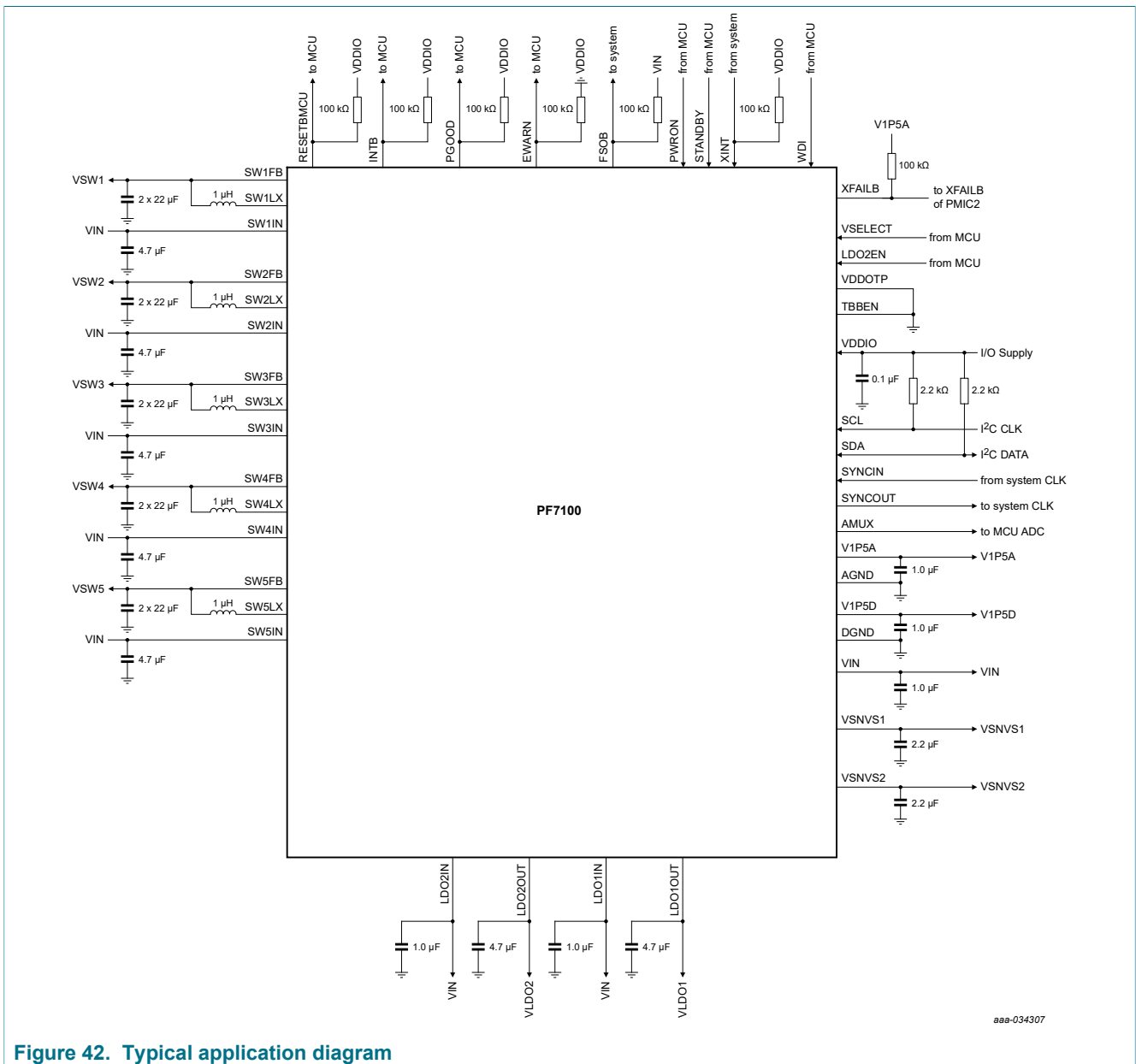
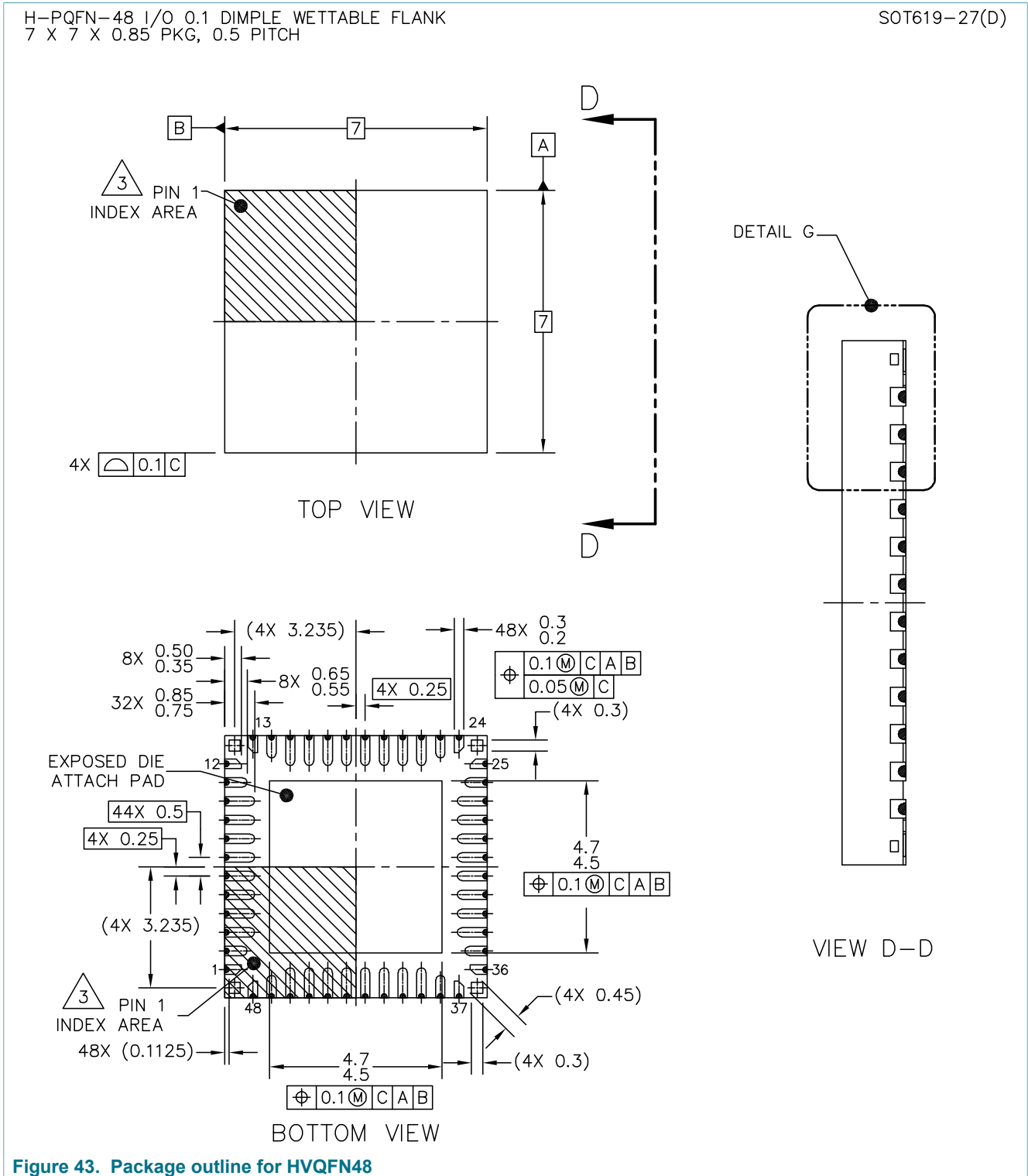

Figure 42. Typical application diagram

21 Package information

21.1 Package outline for HVQFN48



H-PQFN-48 I/O 0.1 DIMPLE WETTABLE FLANK
7 X 7 X 0.85 PKG, 0.5 PITCH

SOT619-27(D)

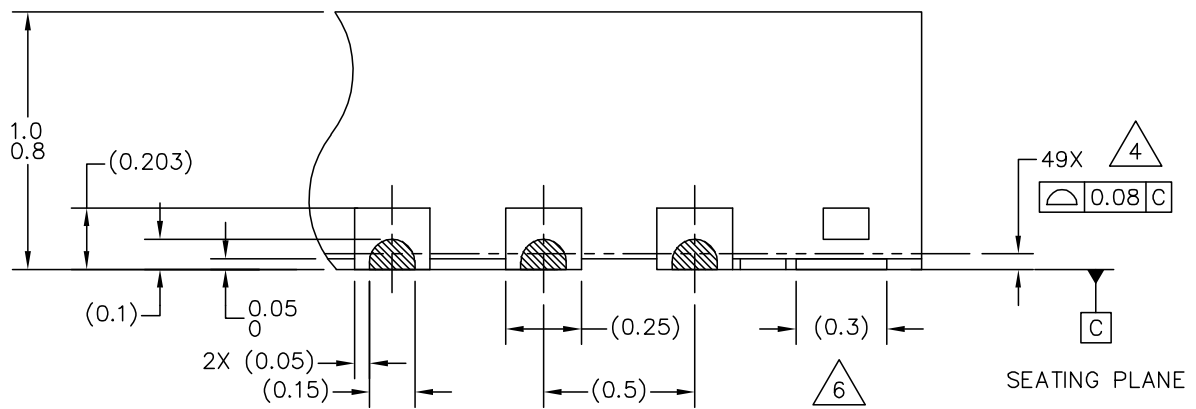

DETAIL G
VIEW ROTATED 90° CW

Figure 44. Package outline detail for HVQFN48

H-PQFN-48 I/O 0.1 DIMPLE WETTABLE FLANK
7 X 7 X 0.85 PKG, 0.5 PITCH

SOT619-27(D)

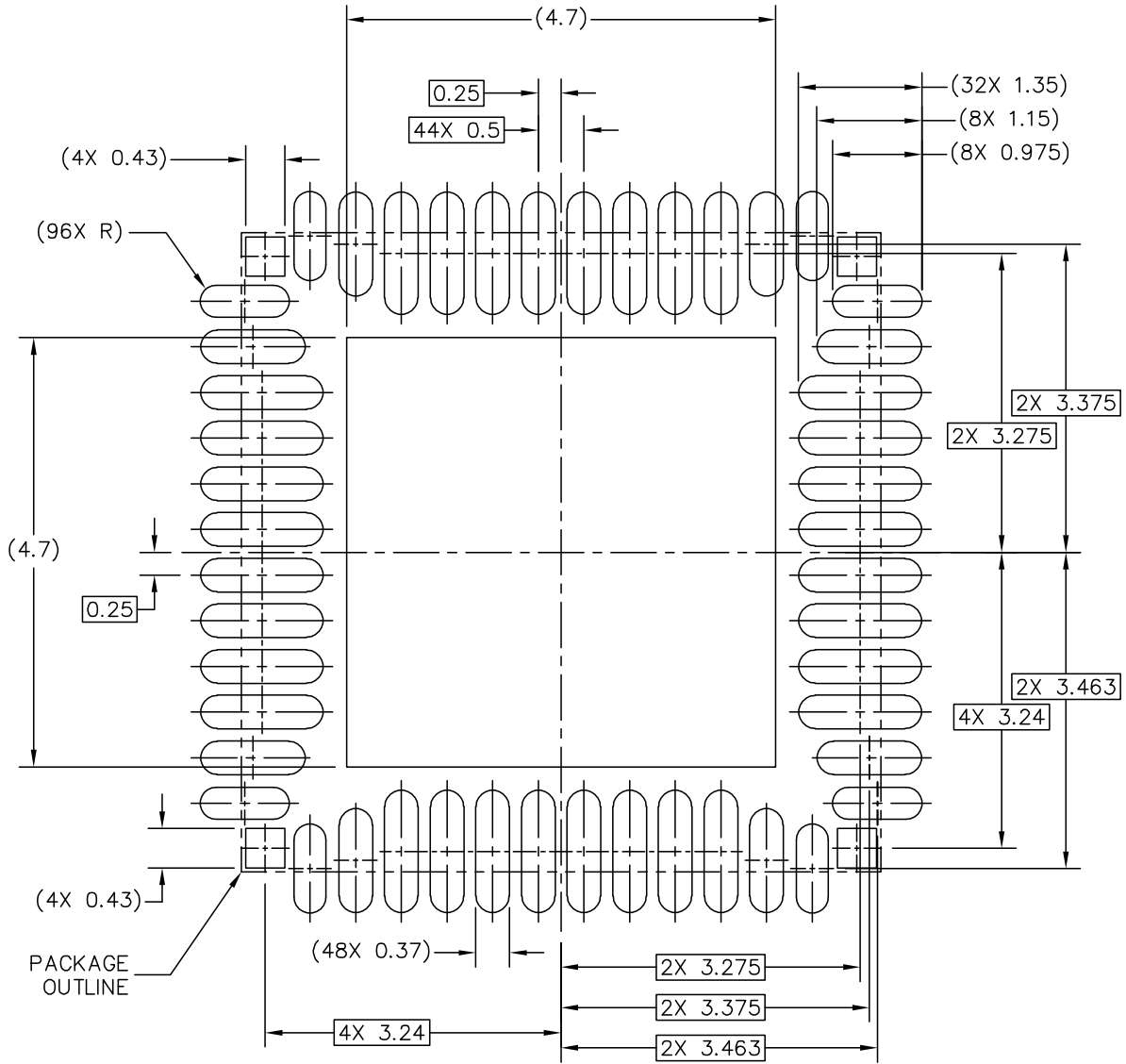

Figure 45. Solder mask pattern for HVQFN48

H-PQFN-48 I/O 0.1 DIMPLE WETTABLE FLANK
7 X 7 X 0.85 PKG, 0.5 PITCH

SOT619-27(D)

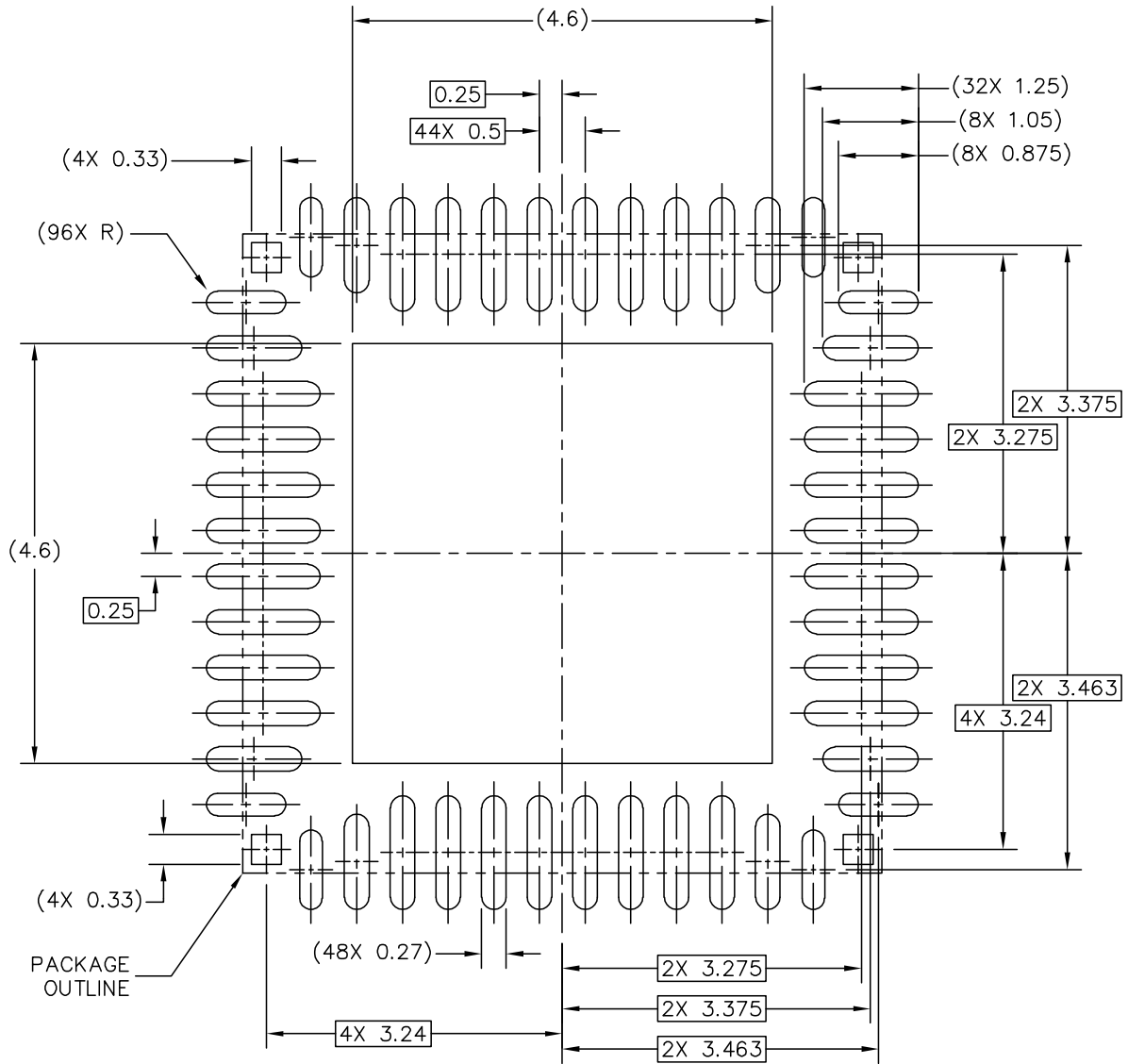

Figure 46. I/O pads and solderable areas for HVQFN48

H-PQFN-48 I/O 0.1 DIMPLE WETTABLE FLANK
7 X 7 X 0.85 PKG, 0.5 PITCH

SOT619-27(D)

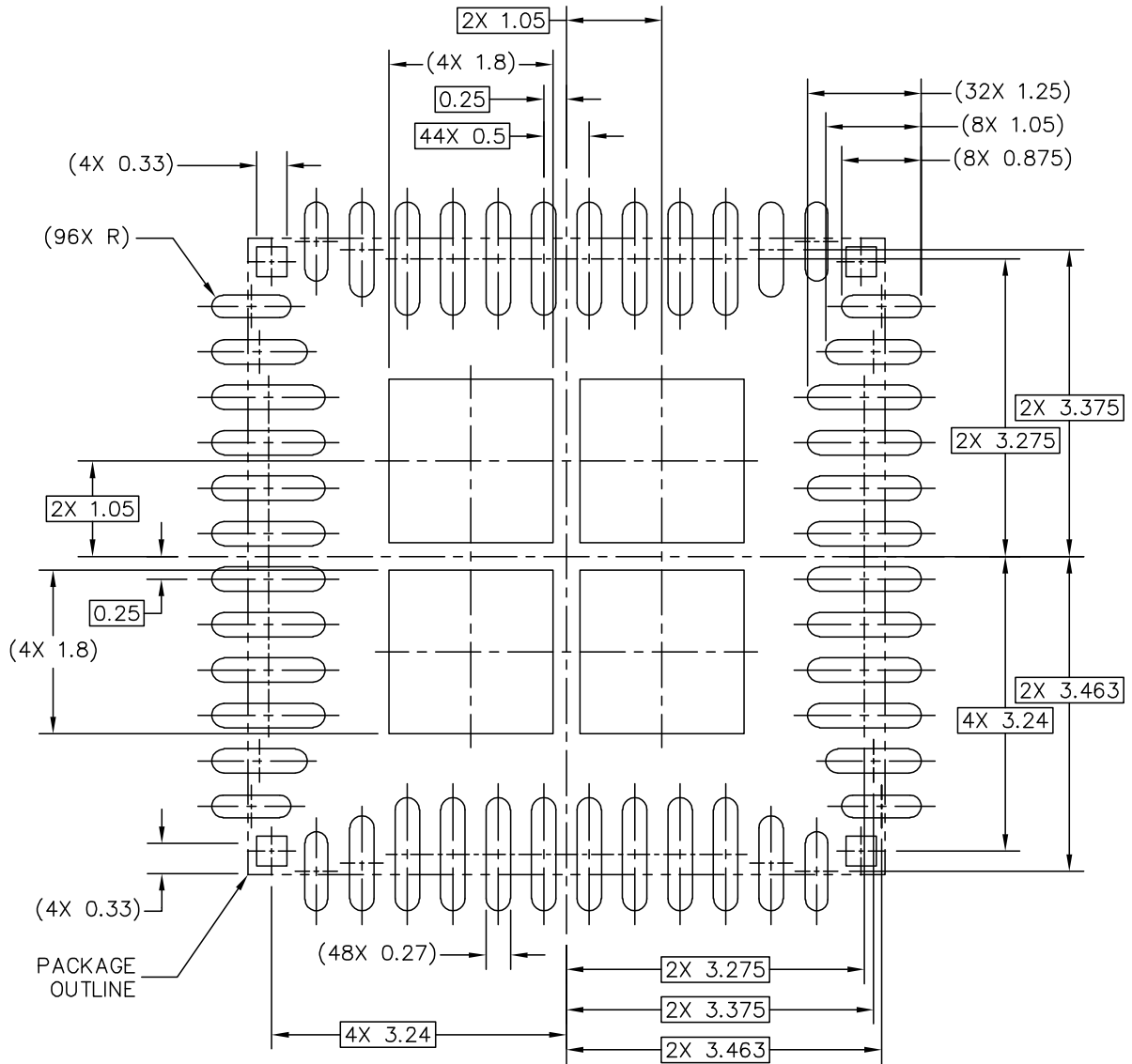

Figure 47. Solder paste stencil for HVQFN48

H-PQFN-48 I/O 0.1 DIMPLE WETTABLE FLANK
7 X 7 X 0.85 PKG, 0.5 PITCH

SOT619-27(D)

NOTES:

1. ALL DIMENSIONS ARE IN MILLIMETERS.
2. DIMENSIONING AND TOLERANCING PER ASME Y14.5M-1994.

3. PIN ONE CONFIGURATION MAY VARY.

4. COPLANARITY APPLIES TO LEADS AND DIE ATTACH PAD.

5. MIN. METAL GAP SHOULD BE 0.25 MM.

6. ANCHORING PADS.

Figure 48. Package outline notes for HVQFN48

22 Revision history

Table 77. Revision history

Document ID	Release date	Data sheet status	Change notice	Supersedes
PF7100 v.4	20210309	Product data sheet	CIN 2021030071	PF7100 v.3
Modifications	<ul style="list-style-type: none"> • Table 6: updated storage temperature (replaced -40 by -55) • Table 50: changed output voltage accuracy from $\pm 2.0\%$ to $\pm 1.5\%$ for VSWxACC ($0.8\text{ V} \leq \text{VSWxFB} \leq 1.0\text{ V}$) • Section 14.9.13: updated Figure 22 			
PF7100 v.3	20201016	Product data sheet	-	PF7100 v.2
Modifications	<ul style="list-style-type: none"> • Section 13: updated Figure 6 and added new transitions to the State machine transition definition table in order to clarify missing conditions related to the XFAILB during power up and power down events 			
PF7100 v.2	20200812	Product data sheet	-	PF7100 v.1
Modifications	<ul style="list-style-type: none"> • Table 2: added OTP links • Table 50: updated V_{SWxACC} values 			
PF7100 v.1	20200707	Product data sheet	-	-

23 Legal information

23.1 Data sheet status

Document status ^{[1][2]}	Product status ^[3]	Definition
Objective [short] data sheet	Development	This document contains data from the objective specification for product development.
Preliminary [short] data sheet	Qualification	This document contains data from the preliminary specification.
Product [short] data sheet	Production	This document contains the product specification.

[1] Please consult the most recently issued document before initiating or completing a design.

[2] The term 'short data sheet' is explained in section "Definitions".

[3] The product status of device(s) described in this document may have changed since this document was published and may differ in case of multiple devices. The latest product status information is available on the Internet at URL <http://www.nxp.com>.

23.2 Definitions

Draft — The document is a draft version only. The content is still under internal review and subject to formal approval, which may result in modifications or additions. NXP Semiconductors does not give any representations or warranties as to the accuracy or completeness of information included herein and shall have no liability for the consequences of use of such information.

Short data sheet — A short data sheet is an extract from a full data sheet with the same product type number(s) and title. A short data sheet is intended for quick reference only and should not be relied upon to contain detailed and full information. For detailed and full information see the relevant full data sheet, which is available on request via the local NXP Semiconductors sales office. In case of any inconsistency or conflict with the short data sheet, the full data sheet shall prevail.

Product specification — The information and data provided in a Product data sheet shall define the specification of the product as agreed between NXP Semiconductors and its customer, unless NXP Semiconductors and customer have explicitly agreed otherwise in writing. In no event however, shall an agreement be valid in which the NXP Semiconductors product is deemed to offer functions and qualities beyond those described in the Product data sheet.

23.3 Disclaimers

Limited warranty and liability — Information in this document is believed to be accurate and reliable. However, NXP Semiconductors does not give any representations or warranties, expressed or implied, as to the accuracy or completeness of such information and shall have no liability for the consequences of use of such information. NXP Semiconductors takes no responsibility for the content in this document if provided by an information source outside of NXP Semiconductors. In no event shall NXP Semiconductors be liable for any indirect, incidental, punitive, special or consequential damages (including - without limitation - lost profits, lost savings, business interruption, costs related to the removal or replacement of any products or rework charges) whether or not such damages are based on tort (including negligence), warranty, breach of contract or any other legal theory. Notwithstanding any damages that customer might incur for any reason whatsoever, NXP Semiconductors' aggregate and cumulative liability towards customer for the products described herein shall be limited in accordance with the Terms and conditions of commercial sale of NXP Semiconductors.

Right to make changes — NXP Semiconductors reserves the right to make changes to information published in this document, including without limitation specifications and product descriptions, at any time and without

notice. This document supersedes and replaces all information supplied prior to the publication hereof.

Applications — Applications that are described herein for any of these products are for illustrative purposes only. NXP Semiconductors makes no representation or warranty that such applications will be suitable for the specified use without further testing or modification. Customers are responsible for the design and operation of their applications and products using NXP Semiconductors products, and NXP Semiconductors accepts no liability for any assistance with applications or customer product design. It is customer's sole responsibility to determine whether the NXP Semiconductors product is suitable and fit for the customer's applications and products planned, as well as for the planned application and use of customer's third party customer(s). Customers should provide appropriate design and operating safeguards to minimize the risks associated with their applications and products. NXP Semiconductors does not accept any liability related to any default, damage, costs or problem which is based on any weakness or default in the customer's applications or products, or the application or use by customer's third party customer(s). Customer is responsible for doing all necessary testing for the customer's applications and products using NXP Semiconductors products in order to avoid a default of the applications and the products or of the application or use by customer's third party customer(s). NXP does not accept any liability in this respect.

Limiting values — Stress above one or more limiting values (as defined in the Absolute Maximum Ratings System of IEC 60134) will cause permanent damage to the device. Limiting values are stress ratings only and (proper) operation of the device at these or any other conditions above those given in the Recommended operating conditions section (if present) or the Characteristics sections of this document is not warranted. Constant or repeated exposure to limiting values will permanently and irreversibly affect the quality and reliability of the device.

Terms and conditions of commercial sale — NXP Semiconductors products are sold subject to the general terms and conditions of commercial sale, as published at <http://www.nxp.com/profile/terms>, unless otherwise agreed in a valid written individual agreement. In case an individual agreement is concluded only the terms and conditions of the respective agreement shall apply. NXP Semiconductors hereby expressly objects to applying the customer's general terms and conditions with regard to the purchase of NXP Semiconductors products by customer.

No offer to sell or license — Nothing in this document may be interpreted or construed as an offer to sell products that is open for acceptance or the grant, conveyance or implication of any license under any copyrights, patents or other industrial or intellectual property rights.

Suitability for use in automotive applications — This NXP Semiconductors product has been qualified for use in automotive applications. Unless otherwise agreed in writing, the product is not designed, authorized or warranted to be suitable for use in life support, life-critical or safety-critical systems or equipment, nor in applications where failure or malfunction of an NXP Semiconductors product can reasonably be expected

to result in personal injury, death or severe property or environmental damage. NXP Semiconductors and its suppliers accept no liability for inclusion and/or use of NXP Semiconductors products in such equipment or applications and therefore such inclusion and/or use is at the customer's own risk.

Export control — This document as well as the item(s) described herein may be subject to export control regulations. Export might require a prior authorization from competent authorities.

Translations — A non-English (translated) version of a document is for reference only. The English version shall prevail in case of any discrepancy between the translated and English versions.

23.4 Trademarks

Notice: All referenced brands, product names, service names and trademarks are the property of their respective owners.

NXP — is a trademark of NXP B.V.

Tables

Tab. 1.	Device information	2	Tab. 38.	VSNVS1 operation description	56
Tab. 2.	Ordering information	2	Tab. 39.	VSNVS1 output voltage configuration	57
Tab. 3.	Pin definitions	5	Tab. 40.	VSNVS2 output voltage configuration	57
Tab. 4.	Absolute maximum ratings	6	Tab. 41.	VSNVSx electrical characteristics	57
Tab. 5.	ESD ratings	7	Tab. 42.	SW1 to SW4 ramp rates	59
Tab. 6.	Thermal characteristics	7	Tab. 43.	SW1 to SW4 output voltage configuration	59
Tab. 7.	HVQFN48 thermal resistance and package dissipation ratings	7	Tab. 44.	SW regulator mode configuration	60
Tab. 8.	Operating conditions	7	Tab. 45.	SWx current limit selection	60
Tab. 9.	Voltage supply summary	9	Tab. 46.	SWx phase configuration	61
Tab. 10.	Device differences	10	Tab. 47.	SWx inductor selection bits	61
Tab. 11.	State machine transition definition	12	Tab. 48.	OTP_SW1CONFIG register description	62
Tab. 12.	Fail-safe OK timer configuration	20	Tab. 49.	OTP_SW4CONFIG register description	62
Tab. 13.	UVDET threshold	21	Tab. 50.	Type 1 buck regulator electrical characteristics	64
Tab. 14.	VIN_OVLO debounce configuration	21	Tab. 51.	Recommended external components	67
Tab. 15.	VIN_OVLO specifications	22	Tab. 52.	SW5 output voltage configuration	68
Tab. 16.	Startup timing requirements (PWRON pulled up)	23	Tab. 53.	SW5 regulator mode configuration	69
Tab. 17.	Startup with PWRON driven high externally and LPM_OFF = 0	24	Tab. 54.	SW5 current limit selection	70
Tab. 18.	Power up timebase register	25	Tab. 55.	SW5 phase configuration	70
Tab. 19.	Power up sequence registers	26	Tab. 56.	SW5 inductor selection bits	70
Tab. 20.	Power down regulator group bits	29	Tab. 57.	Type 2 buck regulator electrical characteristics	71
Tab. 21.	Power down counter delay	30	Tab. 58.	Recommended external components	72
Tab. 22.	Programmable delay after RESETBMCU is asserted	30	Tab. 59.	LDO operation description	73
Tab. 23.	Power down delay selection	31	Tab. 60.	LDO output voltage configuration	74
Tab. 24.	Regulator control during fault event bits	33	Tab. 61.	LDO regulator electrical characteristics	74
Tab. 25.	Fault timer register configuration	35	Tab. 62.	UV threshold configuration register	76
Tab. 26.	Fault bypass bits	36	Tab. 63.	OV threshold configuration register	76
Tab. 27.	Interrupt registers	40	Tab. 64.	UV debounce timer configuration	76
Tab. 28.	I/O electrical specifications	41	Tab. 65.	OV debounce timer configuration	76
Tab. 29.	PWRON debounce configuration in edge detection mode	43	Tab. 66.	VMON electrical characteristics	79
Tab. 30.	TRESET configuration	43	Tab. 67.	Manual frequency tuning configuration	81
Tab. 31.	Standby pin polarity control	44	Tab. 68.	Clock management specifications	84
Tab. 32.	EWARN time configuration	46	Tab. 69.	Thermal monitor specifications	85
Tab. 33.	Early warning threshold	46	Tab. 70.	Thermal monitor bit description	87
Tab. 34.	LDO control in run or standby mode	47	Tab. 71.	AMUX channel selection	87
Tab. 35.	I2C address configuration	53	Tab. 72.	AMUX specifications	88
Tab. 36.	Secure bits	54	Tab. 73.	Watchdog duration register	89
Tab. 37.	Internal supplies electrical characteristics	56	Tab. 74.	Soft WD register reset	91
			Tab. 75.	Default hardware configuration	108
			Tab. 76.	Quiescent current requirements	111
			Tab. 77.	Revision history	119

Figures

Fig. 1.	Simplified application diagram	1	Fig. 9.	Power up/down sequence between OFF and system-on states	27
Fig. 2.	Simplified application diagram with SAF5400 DSRC (V2X) modem	2	Fig. 10.	Power up/down sequence between run and standby	27
Fig. 3.	Internal block diagram	4	Fig. 11.	Group power down sequence example	31
Fig. 4.	Pin configuration for HVQFN48	5	Fig. 12.	Power down delay	32
Fig. 5.	Functional block diagram	9	Fig. 13.	Regulator turned off upon with RegX_ STATE = 0 and FLT_REN = 0	33
Fig. 6.	State diagram	11	Fig. 14.	Regulator turned off upon with RegX_ STATE = 0 and FLT_REN = 1	34
Fig. 7.	Startup with PWRON pulled up	23			
Fig. 8.	Startup with PWRON driven high externally and bit LPM_OFF = 0	24			

Fig. 15.	Correct power up (no fault during power up)	37	Fig. 30.	LDOx regulator block diagram	73
Fig. 16.	Power up sequencer with a temporary failure ..	38	Fig. 31.	Voltage monitoring architecture	78
Fig. 17.	Power up sequencer aborted as fault persists for longer than 2.0 ms	39	Fig. 32.	Clock management architecture	80
Fig. 18.	I/O interface diagram	41	Fig. 33.	Spread-spectrum waveforms	82
Fig. 19.	XFAILB behavior during a power up sequence	51	Fig. 34.	Thermal monitoring architecture	85
Fig. 20.	XFAILB behavior during a power down sequence	51	Fig. 35.	Thermal sensor voltage characteristics	86
Fig. 21.	Behavior during an external XFAILB event	52	Fig. 36.	Watchdog timer operation	90
Fig. 22.	External XFAILB event during a power up sequence	52	Fig. 37.	Soft WD reset behavior	93
Fig. 23.	8-bit SAE J1850 CRC polynomial	53	Fig. 38.	Hard WD reset behavior	93
Fig. 24.	VSNVSx block diagram	57	Fig. 39.	Watchdog event counter	94
Fig. 25.	Buck regulator block diagram	58	Fig. 40.	TBB operation diagram	106
Fig. 26.	Dual phase configuration	63	Fig. 41.	Hardwire operation diagram	108
Fig. 27.	Triple phase configuration	63	Fig. 42.	Typical application diagram	112
Fig. 28.	Quad phase configuration	64	Fig. 43.	Package outline for HVQFN48	113
Fig. 29.	Type 2 buck regulator block diagram	68	Fig. 44.	Package outline detail for HVQFN48	114
			Fig. 45.	Solder mask pattern for HVQFN48	115
			Fig. 46.	I/O pads and solderable areas for HVQFN48 .	116
			Fig. 47.	Solder paste stencil for HVQFN48	117
			Fig. 48.	Package outline notes for HVQFN48	118

Contents

1	Overview	1	14.9.6	WDI	45
2	Features	1	14.9.7	EWARN	45
3	Simplified application diagram	1	14.9.8	PGOOD	46
4	Ordering information	2	14.9.9	VSELECT	47
5	Applications	3	14.9.10	LDO2EN	47
6	Internal block diagram	4	14.9.11	F SOB (safety output)	48
7	Pinning information	5	14.9.11.1	F SOB active safe state (ASIL B device only) ...	48
7.1	Pinning	5	14.9.11.2	F SOB fault safe state	49
7.2	Pin definitions	5	14.9.12	TBBEN	50
8	Absolute maximum ratings	6	14.9.13	XFAILB	50
9	ESD ratings	7	14.9.14	SDA and SCL (I2C bus)	52
10	Thermal characteristics	7	14.9.14.1	I2C CRC verification	53
11	Operating conditions	7	14.9.14.2	I2C secure write	54
12	General description	8	15	Functional blocks	55
12.1	Features	8	15.1	Analog core and internal voltage references ...	55
12.2	Functional block diagram	9	15.2	VSNVS LDOs	56
12.3	Power tree summary	9	15.3	Type 1 buck regulators (SW1 to SW4)	58
12.4	Device differences	10	15.3.1	SW3 VTT operation	61
13	State machine	11	15.3.2	Multiphase operation	62
13.1	States description	15	15.3.3	Electrical characteristics	64
13.1.1	OTP/TRIM load	15	15.4	Type 2 buck regulator (SW5)	67
13.1.2	LP_Off state	16	15.4.1	Electrical characteristics	71
13.1.3	Self-test routine (ASIL B only)	16	15.5	Linear regulators	72
13.1.4	QPU_Off state	16	15.5.1	LDO load switch operation	74
13.1.5	Power up sequence	17	15.5.2	LDO regulator electrical characteristics	74
13.1.6	System-on states	17	15.6	Voltage monitoring	75
13.1.6.1	Run state	17	15.6.1	Voltage monitoring architecture	77
13.1.6.2	Standby state	18	15.6.2	Electrical characteristics	79
13.1.7	WD_Reset	19	15.7	Clock management	79
13.1.8	Power down state	19	15.7.1	Low frequency clock	80
13.1.9	Fail-safe transition	19	15.7.2	High frequency clock	80
13.1.10	Fail-safe state (ASIL B only)	20	15.7.3	Manual frequency tuning	80
14	General device operation	21	15.7.4	Spread-spectrum	81
14.1	UVDET	21	15.7.5	Clock synchronization	82
14.2	VIN OVLO condition	21	15.8	Thermal monitors	84
14.3	IC startup timing with PWRON pulled up	22	15.9	Analog multiplexer	87
14.4	IC startup timing with PWRON pulled low during VIN application	23	15.10	Watchdog event management	88
14.5	Power up	25	15.10.1	Internal watchdog timer	89
14.5.1	Power up events	25	15.10.2	Watchdog reset behaviors	91
14.5.2	Power up sequencing	25	16	I2C register map	94
14.6	Power down	28	16.1	PF7100 ASIL B functional register map	95
14.6.1	Turn off events	28	16.2	PF7100 ASIL B OTP mirror register map (page 1)	97
14.6.2	Power down sequencing	28	16.3	PF7100 QM functional register map	100
14.6.2.1	Sequential power down	29	16.4	PF7100 QM OTP mirror register map (page 1)	102
14.6.2.2	Group power down	29	17	OTP/TBB and hardware default configurations	104
14.6.2.3	Power down delay	31	17.1	TBB (Try Before Buy) operation	104
14.7	Fault detection	32	17.2	OTP fuse programming	106
14.7.1	Fault monitoring during power up state	36	17.3	Default hardware configuration	106
14.8	Interrupt management	39	18	Functional safety	110
14.9	I/O interface pins	41	18.1	System safety strategy	110
14.9.1	PWRON	42	18.2	Output voltage monitoring with dedicated band gap reference	110
14.9.2	STANDBY	44	18.3	ABIST verification	110
14.9.3	RESETBMCU	44			
14.9.4	INTB	44			
14.9.5	XINTB	44			