

DESCRIPTION

The MPQ3387L is a step-up converter with 6-channel current sources. It is designed for driving the white LED arrays as backlighting of middle or large size LCD panel.

The MPQ3387L uses peak-current mode as its PWM control architecture. The switching frequency can be programmed by a resistor. It generates an output voltage up to 45V from a 3V to 25V input supply. The MPQ3387L independently regulates the current in each LED string to the value set by an external current-setting resistor.

The MPQ3387L applies 6 internal current sources in each LED string terminal to achieve a current balance with 3% current regulation accuracy between strings. Its low 500mV regulation voltage on LED current sources reduces power loss.

The MPQ3387L features external digital PWM dimming and analog dimming, both of which sharing a single input with 25% PWM duty cycle as a transfer point. The mix-dimming strategy helps to improve the dimming ratio. Also, MPQ3387L automatically transfers the PWM input signal 100Hz to 20kHz frequency to 24kHz to 27.5kHz to eliminate the audible noise.

MPQ3387L has rich protection modes to guarantee safety operation. The protection modes include recoverable OCP (over-current protection), OVP (over-voltage protection), OTP (over-temperature protection), any string of LED short and open protection.

The MPQ3387L is available in TQFN24-4mmX4mm package.

FEATURES

- Guaranteed Industrial/Automotive Temperature Range Limits
- 6-String, Max 45mA/String
- 3V to 25V Input Voltage Range
- 3% Current Matching Accuracy Between Strings
- Programmable Switching Frequency
- Selectable Combined Analog and PWM Dimming Mode or Pure PWM Dimming Mode
- Combined Analog and PWM Dimming Mode with 25% Dimming Transfer Point
- 24kHz to 27.5kHz Output Dimming Frequency to eliminate audible noise
- Cascading Capability with a Single Power Source
- Programmable Over-Voltage Protection
- Recoverable Thermal Shutdown Protection
- Cycle by Cycle Over Current Protection
- Fault Indicator Signal Output(Optional)
- Under-Voltage Lockout
- TQFN24 (4X4mm) Package
- Available in AEC-Q100 Qualified Grade 1

APPLICATIONS

- Notebook PC
- Small LCD TV
- Portable Terminals Display
- Automotive System and Tablet Computer

All MPS parts are lead-free and adhere to the RoHS directive. For MPS green status, please visit MPS website under Products, Quality Assurance page.

"MPS" and "The Future of Analog IC Technology" are Registered Trademarks of Monolithic Power Systems, Inc.

TYPICAL APPLICATION

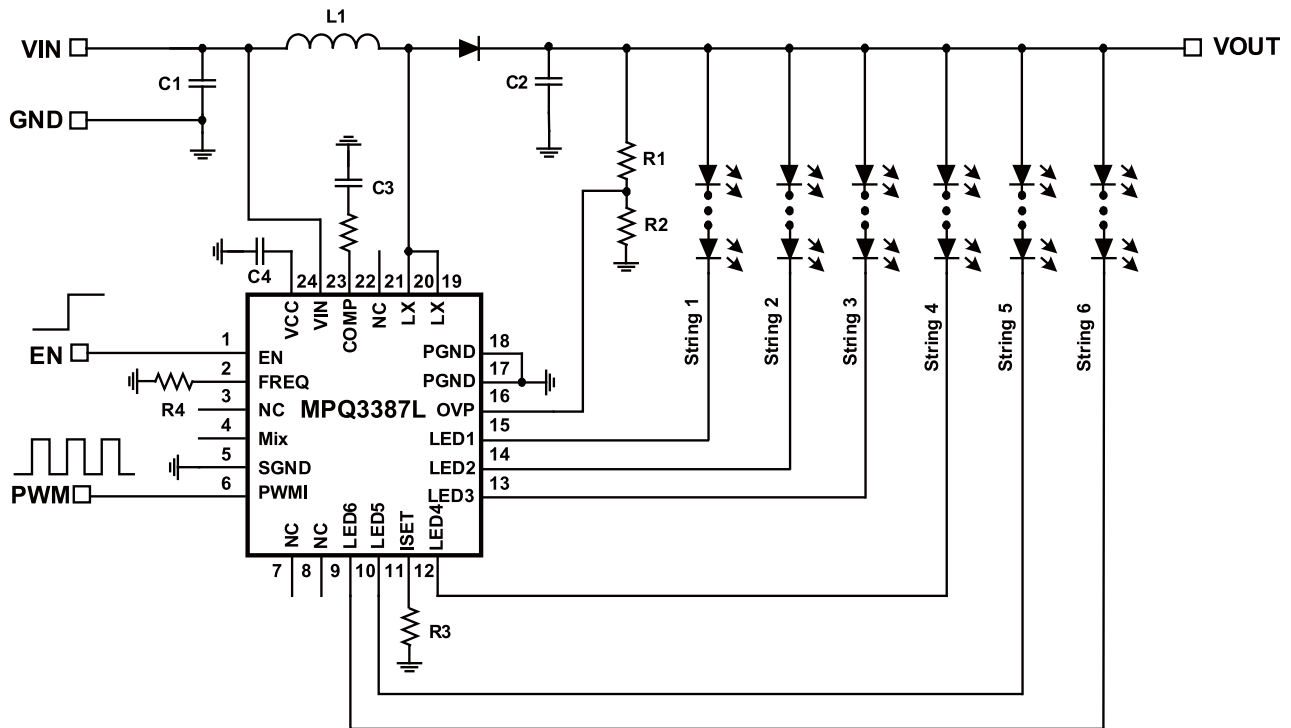

ORDERING INFORMATION

Part Number	Package	Top Marking
MPQ3387LGRT*	TQFN-24 (4mm X4mm)	See Below
MPQ3387LGRT-AEC1**	TQFN-24 (4mm X4mm)	

* For Tape & Reel, add suffix -Z (e.g. MPQ3387LGRT-Z):

** For Tape & Reel, add suffix -Z (e.g. MPQ3387LGRT-AEC1-Z):

TOP MARKING

MPSYWW

M3387L

LLLLLL

MPS: MPS prefix;

Y: year code;

WW: week code;

M3387L: product code of MPQ3387LGRT;

LLLLLL: lot number;

PACKAGE REFERENCE

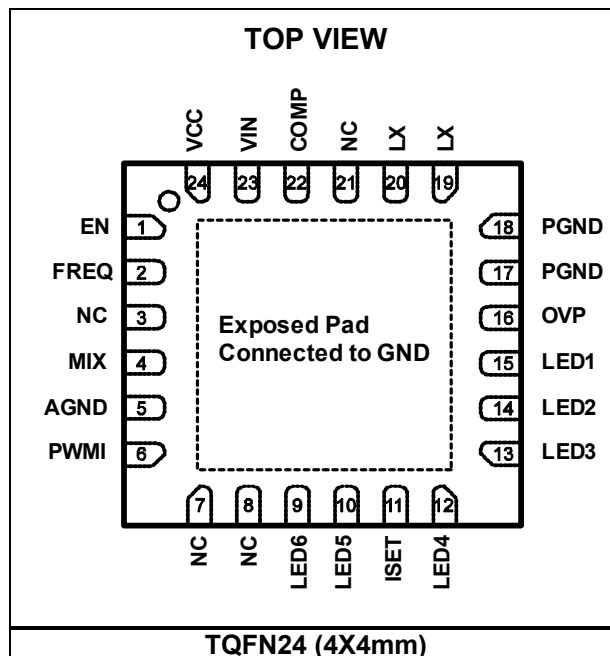

ABSOLUTE MAXIMUM RATINGS ⁽¹⁾

V_{PWMI}, V_{EN}, V_{IN}	-0.3V to +30V
VCC	-0.3V to +6.5V
V_{LX}, V_{LED1} to V_{LED6}	-1V to +50V
All Other Pins	-0.3V to +6V
Junction Temperature	150°C
Lead Temperature	260°C
Continuous Power Dissipation ($T_A = 25^\circ\text{C}$) ⁽²⁾	
TQFN-24 (4mmX4mm)	2.9W

Recommended Operating Conditions ⁽³⁾

Supply Voltage V_{IN}	3V to 25V
Operating Junction Temp.	-40°C to +125°C

Thermal Resistance ⁽⁴⁾	θ_{JA}	θ_{JC}	
TQFN-24 (4mm X4mm).....	42.....	9.....	°C/W

Notes:

- 1) Exceeding these ratings may damage the device.
- 2) The maximum allowable power dissipation is a function of the maximum junction temperature T_J (MAX), the junction-to-ambient thermal resistance θ_{JA} , and the ambient temperature T_A . The maximum allowable continuous power dissipation at any ambient temperature is calculated by P_D (MAX) = $(T_J$ (MAX)- T_A)/ θ_{JA} . Exceeding the maximum allowable power dissipation will cause excessive die temperature, and the regulator will go into thermal shutdown. Internal thermal shutdown circuitry protects the device from permanent damage.
- 3) The device is not guaranteed to function outside of its operating conditions.
- 4) Measured on JESD51-7, 4-layer PCB.

ELECTRICAL CHARACTERISTICS ⁽⁵⁾
 $V_{IN} = 12V$, $V_{EN} = 5V$, $T_J = -40^{\circ}C$ to $+125^{\circ}C$, unless otherwise noted. Typical values are at $T_A = 25^{\circ}C$.

Parameters	Symbol	Condition	Min	Typ	Max	Units
Operating Input Voltage	V_{IN}		3		25	V
Supply Current (Quiescent)	I_Q	$V_{IN}=12V$, $V_{EN}=5V$, no load.		1.6		mA
Supply Current (Shutdown)	I_{ST}	$V_{EN}=0V$, $V_{IN}=12V$			1	μA
LDO Output Voltage	V_{CC}	$V_{EN}=5V$, $6V < V_{IN} < 25V$, $0 < I_{VCC} < 10mA$	4.5	5	5.5	V
VCC UVLO Threshold	V_{IN_UVLO}	Rising Edge	2.4	2.55	2.7	V
					3	
VCC UVLO Hysteresis				200		mV
EN ON Threshold	V_{EN_ON}	V_{EN} Rising	1.5			V
EN OFF Threshold	V_{EN_OFF}	V_{EN} Falling			0.8	V
STEP-UP CONVERTER						
SW On-Resistance	R_{DS_ON}	$I_{DS}=20mA$		0.18	0.3	Ω
					0.4	
SW Leakage Current	I_{SW_LK}	$V_{SW}=45V$			1	μA
Switching Frequency	F_{SW}	RREQ=49.9k Ω	1	1.25	1.5	MHz
		RREQ=100k Ω	532	625	718	kHz
Maximum Duty Cycle	D_{MAX}		90	93	96	%
SW Current Limit	I_{SW_LIMIT}	Duty=90%	2	2.5		A
COMP Transconductance	G_{COMP}	$\Delta I_{COMP} = \pm 10\mu A$		100		$\mu A/V$
CURRENT DIMMING						
PWMI Input Low Threshold	V_{PWMI_LO}	V_{PWM} Falling	0.4			V
PWMI Input High Threshold	V_{PWMI_HI}	V_{PWM} Rising			1.5	V
MIX Input Low Threshold	V_{MIX_LO}	V_{MIX} Falling	0.4			V
MIX Input High Threshold	V_{MIX_HI}	V_{MIX} Rising			1.5	V
PWMI Dimming Output Frequency	F_{PWMO}		24k	22k	27.5k	Hz
PWMI Dimming Input Transfer Point				25		%
PWMI Dimming Transfer Point Hysteresis				0.2		%
PWMI Leakage Current	I_{PWMI_LK}	$V_{PWMI} = 5V$		10	15	μA
		$V_{PWMI} = 0V$			1	μA
LED CURRENT REGULATION						
LEDX Average Current	I_{LED}	$R_{ISET}=60.4k\Omega$	19.4	20	20.6	mA
Current Matching ⁽⁵⁾		$I_{LED}=20mA$			3	%
Maximum LED Current per String	I_{LEDmax}			45		mA

ELECTRICAL CHARACTERISTICS (continued)
 $V_{IN} = 12V$, $V_{EN} = 5V$, $T_J = -40^{\circ}C$ to $+125^{\circ}C$, unless otherwise noted. Typical values are at $T_A = 25^{\circ}C$.

Parameters	Symbol	Condition	Min	Typ	Max	Units
ISET Regulation Voltage			1.217	1.241	1.264	V
LEDX Regulation Voltage	V_{LEDX}	$I_{LED}=20mA$	400	500	600	mV
PROTECTION						
Over Voltage Protection Threshold	V_{OVP_OV}	Rising Edge	1.16	1.2	1.24	V
OVP UVLO threshold	V_{OVP_UV}	Step-up Converter Fails	50	80	110	mV
LEDX Over Voltage Threshold	V_{LEDX_OV}	$V_{IN}>5.5V$	5.1	5.5	5.9	V
					6.1	
LEDX UVLO Threshold	V_{LEDX_UV}		180	275	370	mV
Thermal Shutdown Threshold ⁽⁶⁾	T_{ST}			150		$^{\circ}C$
Thermal Shutdown Hysteresis				20		$^{\circ}C$
LEDX Over Voltage Fault Timer		$Fs=1.25MHz$	1.3	1.6	1.9	ms

Notes:

- 5) Matching is defined as the difference of the maximum to minimum current divided by the setting current.
 6) Guaranteed by design.

TYPICAL PERFORMANCE CHARACTERISTICS

$V_{IN} = 12V$, 10 LEDs in series, 6 strings parallel, 20mA/string, $T_A = 25^\circ C$, unless otherwise noted.

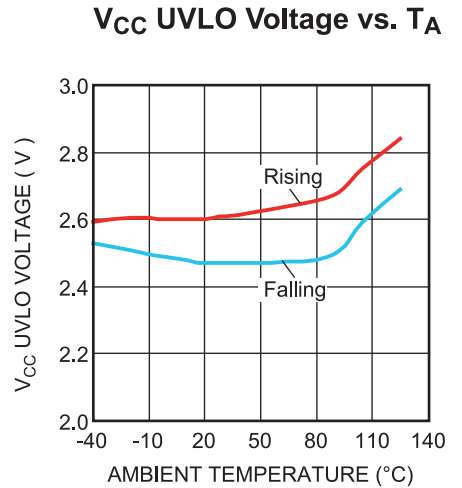
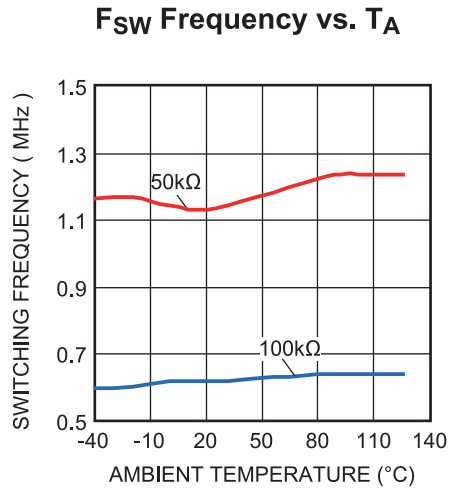
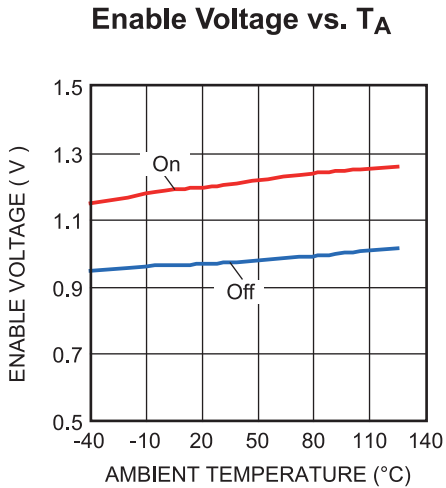
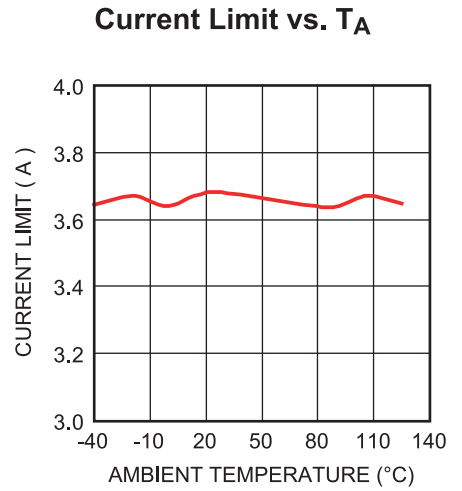
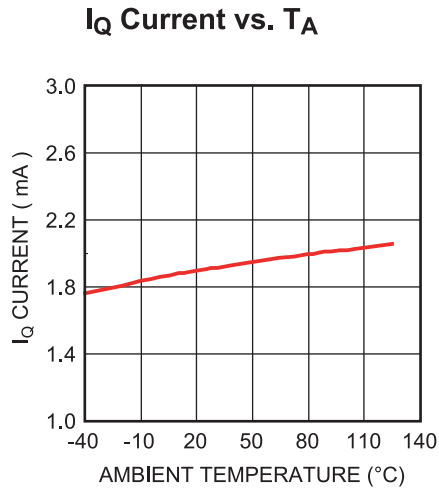
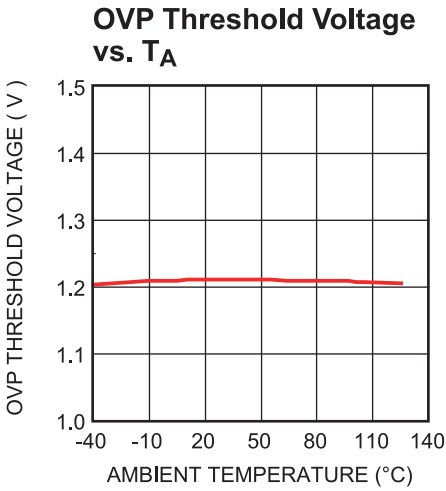

TYPICAL PERFORMANCE CHARACTERISTICS

$V_{IN} = 12V$, 10 LEDs in series, 6 strings parallel, 20mA/string, $T_A = 25^\circ C$, unless otherwise noted.

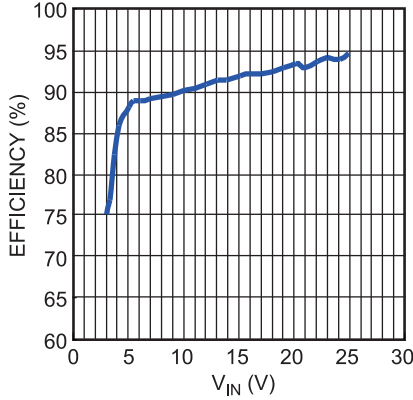
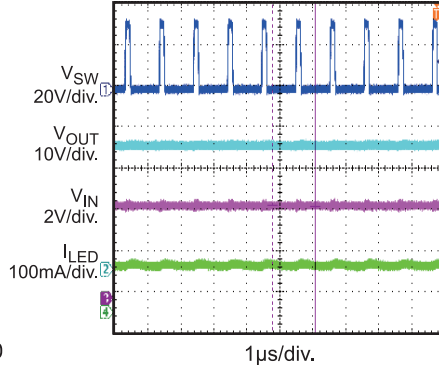
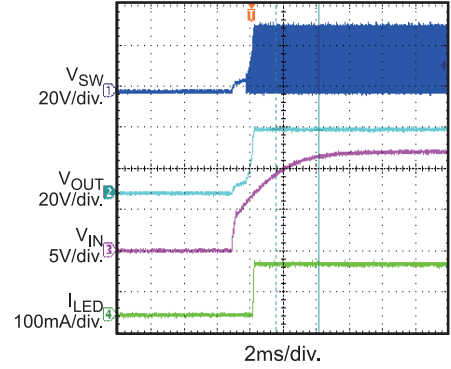
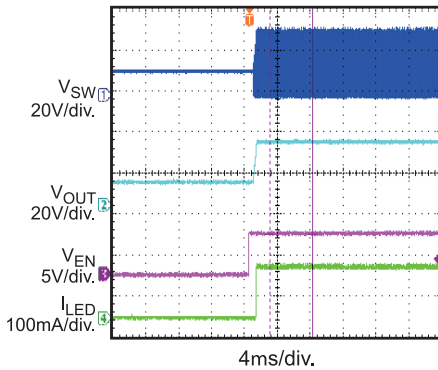
Efficiency

Steady State

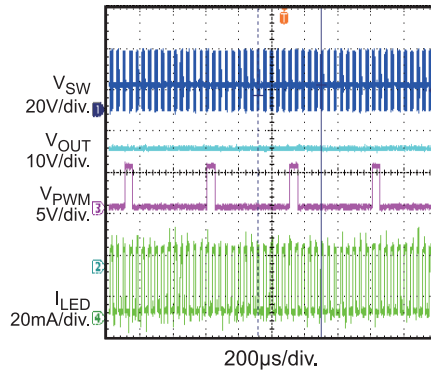
 V_{IN} Power On

EN Power On

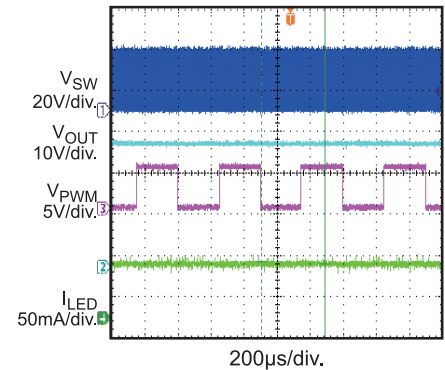
Dimming in Mix Mode

$f_{PWM} = 2kHz$, $D_{PWM} = 10\%$

Dimming in Mix Mode

$f_{PWM} = 2kHz$, $D_{PWM} = 50\%$

Dimming in External PWM Mode

$f_{PWM} = 2kHz$, $D_{PWM} = 50\%$

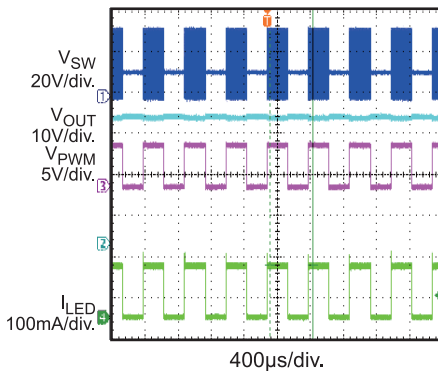
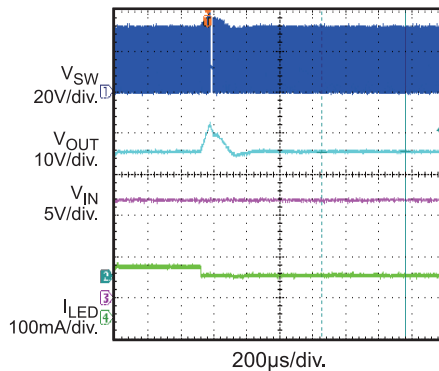
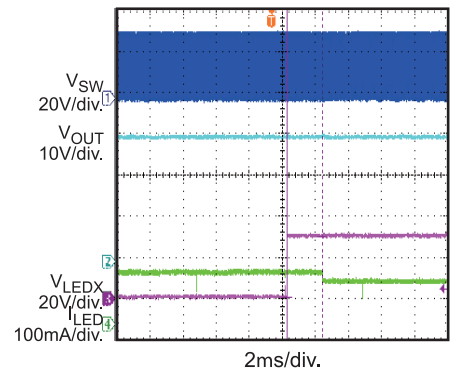
Open LED Protection

Short LED Protection

PIN FUNCTIONS

Package Pin #	Name	Description
1	EN	Enable Control Input. Internally weakly pulled to low.
2	FREQ	Switching Frequency Setting Pin. Connect a resistor between this pin and GND to set the converter's switching frequency.
3	NC	No Connect Pin. Leave this pin float.
4	MIX	Dimming Mode Select Pin. Pulled to high to select combined analog and PWM dimming mode with 25% transfer point. Pulled to low to select direct PWM dimming mode. In default, this pin is pulled to high.
5	AGND	Analog Ground.
6	PWMI	PWM Signal Input. Apply a PWM signal on this pin for brightness control. Dimming signal with 100Hz to 20kHz is recommended. Internally weakly pulled to low.
7	NC	No Connect Pin. Leave this pin float.
8	NC	No Connect Pin. Leave this pin float.
9	LED6	LED String 6 Current Input. This pin is the open-drain output of an internal dimming control switch. Connect the LED String 6 cathode to this pin.
10	LED5	LED String 5 Current Input. This pin is the open-drain output of an internal dimming control switch. Connect the LED String 5 cathode to this pin.
11	ISET	LED Current Setting. Tie a current setting resistor from this pin to ground to program the current in each LED string.
12	LED4	LED String 4 Current Input. This pin is the open-drain output of an internal dimming control switch. Connect the LED String 4 cathode to this pin.
13	LED3	LED String 3 Current Input. This pin is the open-drain output of an internal dimming control switch. Connect the LED String 3 cathode to this pin.
14	LED2	LED String 2 Current Input. This pin is the open-drain output of an internal dimming control switch. Connect the LED String 2 cathode to this pin.
15	LED1	LED String 1 Current Input. This pin is the open-drain output of an internal dimming control switch. Connect the LED String 1 cathode to this pin.
16	OVP	Over-voltage Protection Input. Connect a resistor divider from output to this pin to program the OVP threshold.
17	PGND1	Step-up Converter Power Ground.
18	PGND2	Step-up Converter Power Ground. PGND1 and PGND2 should be shorted externally.
19	LX2	Step-up Converter Power Switch Output. LX2 is the drain of the internal MOSFET switch. Connect the power inductor and output rectifier to LX2. LX1 and LX2 should be shorted externally.
20	LX1	Step-up Converter Power Switch Output. LX1 is the drain of the internal MOSFET switch. Connect the power inductor and output rectifier to LX1. LX1 and LX2 should be shorted externally.
21	NC	No Connect Pin. Leave this pin float. (Optional for Fault Flag Pin, open drain during normal operation, pulled to low in fault mode.)
22	COMP	Step-up Converter Compensation Pin. This pin is used to compensate the regulation control loop. Connect a capacitor or a series RC network from COMP to GND.
23	VIN	Power Supply Input. VIN supplies the power to the IC. Drive VIN with a 3V to 25V power source. Must be locally bypassed.

PIN FUNCTIONS *(continued)*

Package Pin #	Name	Description
24	VCC	The Internal 5V Linear Regulator Output. VCC provides power supply for the internal MOSFET switch gate driver and the internal control circuitry. Bypass VCC to GND with a ceramic capacitor. If VIN is less than 5.5V, tie VIN and VCC together.

FUNCTION DIAGRAM

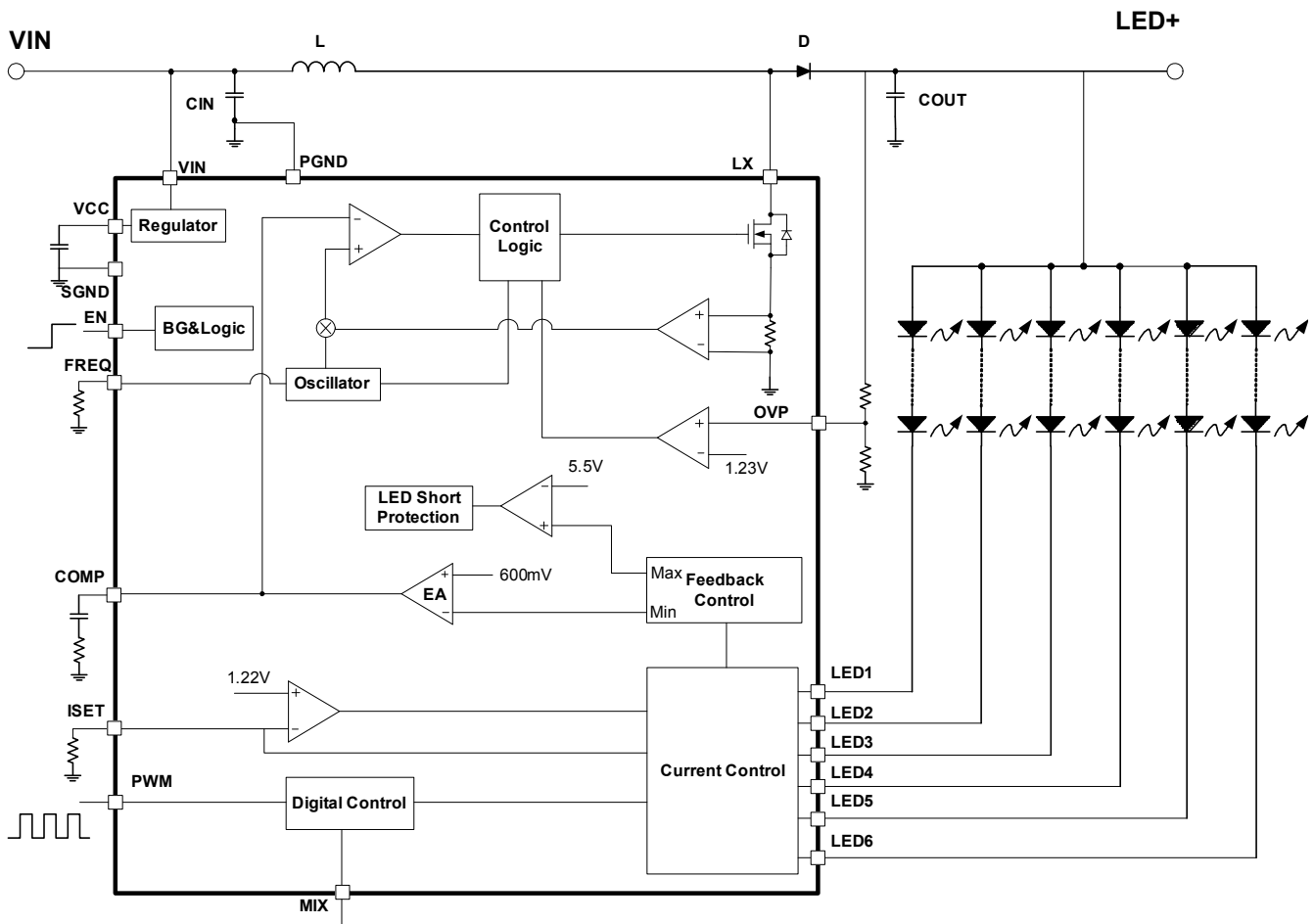

Functional Block Diagram

OPERATION

The MPQ3387L employs a peak current as its PWM mode architecture and has 6-channels current sources to regulate the array of 6 strings white LEDs. The operation of the MPQ3387L can be understood by referring to the block diagram.

Internal 5V Regulator

The MPQ3387L includes an internal linear regulator (VCC). When VIN is greater than 5.5V, this regulator offers a 5V power supply for the internal MOSFET switch gate-driver and the internal control circuitry. The VCC voltage drops to 0V when the chip shuts down. In the application of VIN smaller than 5.5V, tie VCC and VIN together. Also, the MPQ3387L features Under Voltage Lockout and the chip is disabled until VCC exceeds the UVLO threshold. The hysteresis of UVLO is approximately 200mV.

System Startup

When enabled, the MPQ3387L checks the topology connection first. The chip monitors the over-voltage protection (OVP) pin to see whether the Schottky diode is connected or whether the boost output is shorted to GND. An OVP voltage less than 70mV will fail to the switching. The MPQ3387L also checks other safety limits, including UVLO and over-temperature protection (OTP). If detections to all the protections pass, the chip then starts boosting the step-up converter with an internal soft-start.

It is recommended that the enable signal occurs after the establishment of the input voltage and PWM dimming signal during the start-up sequence to avoid large inrush current.

Step-Up Converter

The converter operating frequency is programmed with an external resistor connected to the OSC pin. This helps to optimize the size of external components and the efficiency.

At the beginning of each switching cycle, the internal clock turns on the external MOSFET (In normal operation, the minimum turning-on time is 100ns). A stabilizing ramp added to the

output of the current sense amplifier prevents sub-harmonic oscillations for duty cycles greater than 50 percent. This result is fed into the PWM comparator. When this resulting voltage reaches the output voltage of the error amplifier (V_{COMP}), the external MOSFET turns off.

The output voltage of the internal error amplifier is an amplified signal of the difference between the reference voltage and the feedback voltage. The converter automatically chooses the lowest active LEDX pin voltage to provide a high-enough bus voltage to power all the LED arrays.

If the feedback voltage drops below the reference, the output of the error amplifier increases. It results in more current flowing through the MOSFET, thus increasing the power delivered to the output. This forms a closed loop that regulates the output voltage.

Under light-load operation, especially in the case of $V_{OUT} \approx V_{IN}$, the converter runs in pulse-skipping mode where the MOSFET turns on for a minimum on-time of approximately 100ns, and then the converter discharges the power to the output for the remaining period. The external MOSFET remains off until the output voltage needs to be boosted again.

Dimming Control

The MPQ3387L provides two dimming methods: direct PWM dimming mode or combined analog and PWM dimming mode.

If MIX pin is pulled to high (In default, this pin is pulled to high.), MPQ3387L works in combined analog and PWM dimming mode with 25% as its transfer point. A PWM signal is applied to the PWMI pin. When the duty cycle of PWM dimming signal is $\geq 25\%$, the IC dims the LED current with analog mode and the LED current amplitude is equal to $I_{SET} * D_{DIM}$. (I_{SET} is the LED current set by resistor connected to ISET pin; D_{DIM} is the duty cycle of PWM dimming signal.) Analog dimming helps to reduce the LED power loss and avoid the audible noise issue. When the duty cycle of PWM dimming signal is $< 25\%$,

the IC dims the LED current in PWM mode, the LED current amplitude is fixed to $25\% \cdot I_{SET}$ while the LED dimming duty is 4 times D_{DIM} to make the actual average LED current equal to $I_{SET} \cdot D_{DIM}$. The actual LED current dimming frequency is automatically transferred to the range of 24kHz~27.5kHz from 100 Hz~20kHz of the input PWM dimming signal frequency. By doing this, MPQ3387L not only improves the low LED current dimming ratio but also avoids the troublesome audible noise issue.

If MIX pin is pulled to low, MPQ3387L works under direct PWM dimming mode. The LED current is fixed to I_{SET} , the output LED current is just chopped following to the direct PWM dimming signal duty cycle and frequency. The average output current is equal to $I_{SET} \cdot D_{DIM}$.

Output Over Voltage Protection & Short Protection

In some unexpected cases, in order to avoid the IC keeping charging the output voltage, MPQ3387L has OVP function to protect the components from being damaged by output voltage. If the OVP high protection threshold point 1.2V has been reached, the chip stops switching and thus, the output voltage drops. The switching resumes to normal if the OVP point drops below the recovery threshold.

In addition, MPQ3387L can achieve output short to GND or Diode open protection by detecting OVP pin voltage. The IC works in normal switching only the OVP pin voltage is higher than 70mV.

Open String Protection

Open string protection is achieved by detecting both the OVP pin and the LED (1 to 6) pins. If one or more strings (Not all strings) are open, the respective LEDX pins are pulled to ground and the IC keeps charging the output voltage until OVP reaches the 1.2V protection threshold,

the chip stops switching and marks off the open strings which have an LEDX pin voltage lower than 260mV. Once marked, the remaining LED strings force the output voltage back into right regulation. The string with the largest voltage drop determines the output regulation. In addition, the marked-off strings can resume to normal operation after connected back to the system.

If all 6 strings are open (LED bar is open), the IC keeps charging the output voltage until OVP pin voltage hits 1.2V threshold, then mark off the LED current regulator. The IC resumes to normal current regulation till VIN or EN is reset.

Short String Protection

The MPQ3387L monitors the LEDX pin voltage to judge if the short string occurs. If one or more strings are short, the respective LEDX pins will be pulled up to the boost output and tolerate high voltage stress. If the LEDX pin voltage is higher than 5.5V, the short string condition is detected on the respective string. When the short string fault (LEDX over-voltage fault) continues for greater than 1.6ms, the corresponding string current regulator is disabled and disconnects from the output voltage loop regulation. The LED string will resume to normal current regulation when the short condition is removed.

Thermal Shutdown Protection

To prevent the IC from operating at exceedingly high temperature, thermal shutdown is implemented in this chip by detecting the silicon die temperature. When the die temperature exceeds the upper threshold T_{ST} , the IC shutdowns and recovers to normal operation when die temperature drops below lower threshold. Typically, the hysteresis value is 20°C.

APPLICATION INFORMATION

Selecting the Switching Frequency

The switching frequency of the step-up converter is recommended from 500kHz to 2.5MHz for most of application. An oscillator resistor on FREQ pin sets the internal oscillator frequency for the step-up converter according to the below equation:

$$F_{sw}(kHz) = \frac{62100}{R_{osc}(k\Omega)}$$

For $R_{osc}=100k\Omega$, the switching frequency is set to 625kHz.

Setting the LED Current

The current of each string is identical and set through the current setting resistor on the ISET pin.

$$I_{SET} = 1000 \times \frac{1.21(V)}{R_{SET}(k)}$$

For $R_{SET}=60.4k\Omega$, the LED current is set to 20mA. The ISET pin can not be open.

Selecting the Input Capacitor

The input capacitor reduces the surge current drawn from the input supply and the switching noise from the device. The input capacitor impedance at the switching frequency should be

less than the input source impedance to prevent the high-frequency switching current from passing through to the input. Use ceramic capacitors with X5R or X7R dielectrics for their low ESR and small temperature coefficients. For most applications, a 4.7 μ F ceramic capacitor is sufficient.

Selecting the Inductor

The MPQ3387L requires an inductor to supply a higher output voltage while being driven by the input voltage. A larger value inductor results in less ripple current, lower peak inductor current and less stress on the internal N-channel MOSFET. However, the larger value inductor has a larger physical size, higher series resistance, and lower saturation current.

Choose an inductor that does not saturate under the worst-case load conditions. Select the minimum inductor value to ensure that the boost converter works in continuous conduction mode

with high efficiency and good EMI performance. Calculate the required inductance value using the equation:

$$L \geq \frac{\eta \times V_{OUT} \times D \times (1-D)^2}{2 \times f_{sw} \times I_{LOAD}}$$

$$D = 1 - \frac{V_{IN}}{V_{OUT}}$$

Where V_{IN} and V_{OUT} are the input and output voltages, f_{sw} is the switching frequency, I_{LOAD} is the LED load current, and η is the efficiency.

With given inductor value, the inductor DC current rating is at least 40% higher than the maximum input peak inductor current for most applications. The inductor's DC resistance should be as small as possible to get higher efficiency.

Selecting the Output Capacitor

The output capacitor keeps the output voltage ripple small and ensures feedback loop stability. The output capacitor impedance must be low at the switching frequency. Ceramic capacitors with X7R dielectrics are recommended for their low ESR characteristics. For most applications, a 2.2 μ F ceramic capacitor is sufficient.

Setting the Over Voltage Protection

The open string protection is achieved through the detection of the voltage on the OVP pin. In some unexpected cases, the part keeps boosting the output voltage higher and higher. If the output voltage reaches the programmed OVP threshold, the protection will be triggered.

To ensure the chip functions properly, select the resistor values for the OVP resistor divider to provide an appropriate set voltage. The recommended OVP point is about 1.1 to 1.2 times higher than the output voltage for normal operation.

$$V_{OVP} = 1.2 \times \left(1 + \frac{R_{HIGH}}{R_{LOW}}\right)$$

Selecting Dimming Control Mode

The MPQ3387L provides two different dimming methods.

1. Direct PWM Dimming

Pull MIX pin to low to make MPQ3387L work in direct PWM dimming mode. Apply a PWM dimming signal to PWMI pin, the LED current is fixed to I_{SET} , the output LED current is chopped following to the direct PWM dimming signal duty cycle and frequency. The average output current is equal to $I_{SET} \cdot D_{DIM}$. The input PWM dimming frequency depends on the LED current dimming ratio. Lower input PWM dimming frequency results in better LED dimming ratio. Usually, a 200Hz to 2kHz PWM signal is ok to cover most applications.

2. Analog Dimming

If MIX pin is pulled to high (In default, this pin is pulled to high.), MPQ3387L works in combined analog and PWM dimming mode with 25% as its transfer point. A PWM signal is applied to the PWMI pin. When the duty cycle of PWM dimming signal is $\geq 25\%$, the IC dims the LED current with analog mode and the LED current amplitude is equal to $I_{SET} \cdot D_{DIM}$. (I_{SET} is the LED current set by resistor connected to ISET pin; D_{DIM} is the duty cycle of PWM dimming signal.) Analog dimming helps to reduce the LED power loss and avoid the audible noise issue. When the duty cycle of PWM dimming signal is $< 25\%$, the IC dims the LED current in PWM mode, the LED current amplitude is fixed to $25\% \cdot I_{SET}$ while the LED dimming duty is 4 times D_{DIM} to make the actual average LED current equal to $I_{SET} \cdot D_{DIM}$.

The actual LED current dimming frequency is automatically transferred to the range of 24kHz~27.5kHz from 100Hz~20kHz of the input PWM dimming signal frequency. By doing this, MPQ3387L can not only improve the low LED current dimming ratio but also avoid the troublesome audible noise issue.

Layout Considerations

Careful attention must be paid to the PCB board layout and components placement. Proper layout of the high frequency switching path is critical to prevent noise and electromagnetic interference problems. The loop of LX to PGND pin (U1), output diode (D1), and output capacitor (C2) is flowing with high frequency pulse current. It must be as short as possible (See figure below).

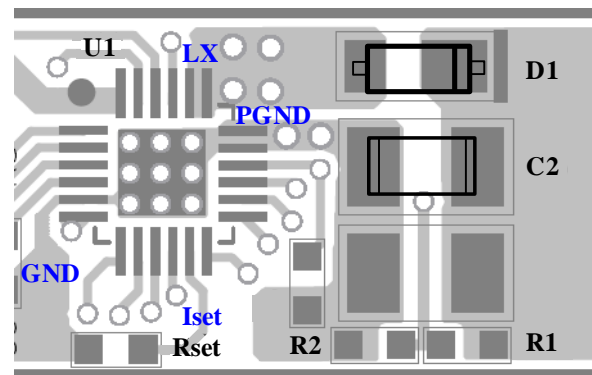

Layout Consideration

The IC exposed pad is internally connected to GND pin, and all logic signals are referred to the GND. The PGND should be externally connected to GND and is recommended to keep away from the logic signals.

TYPICAL APPLICATION CIRCUITS

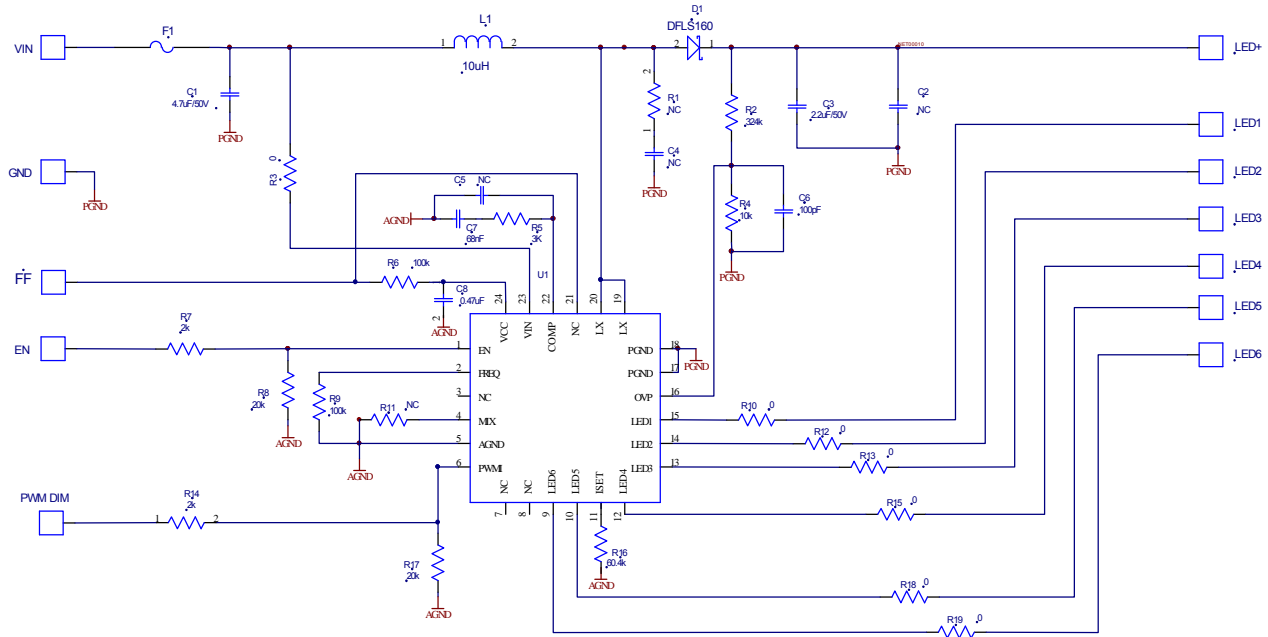

Figure 1: $V_{IN} > 5.5V$, 6string, 20mA/string application

(Some components are reasonably adjustable based on real case)

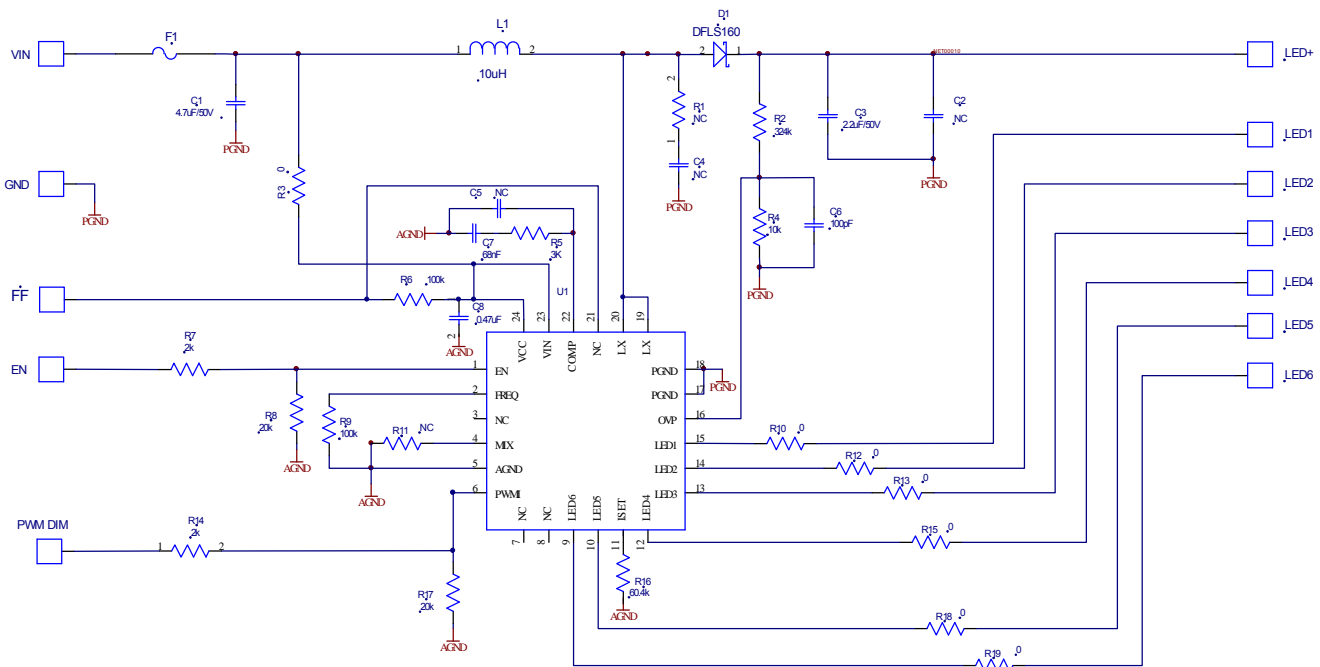

Figure 2: $V_{IN} < 5.5V$, 6string, 20mA/string application

(Tie VIN and VCC together, some components are reasonably adjustable based on real case)