

DESCRIPTION

The MPQ4475-E integrates a monolithic, step-down, switch-mode converter with a single USB current-limit switch and charging port identification circuit. The MPQ4475-E achieves 2.5A of continuous output current with excellent load and line regulation over a wide input supply range.

The output of the USB switch is current-limited. The MPQ4475-E provides a USB-dedicated charging port (DCP), which supports battery charging specification 1.2 (BC1.2), divider mode, and 1.2V/1.2V mode without the need for outside user interaction. The output voltage has programmable line drop compensation.

Full protection features include hiccup current limiting, output over-voltage protection (OVP), and thermal shutdown.

The MPQ4475-E requires a minimal number of readily available, standard, external components and is available in a QFN-25 (4mmx4mm) package.

FEATURES

- Hiccup Over-Current Mode for CR Load
- Wide 7V to 36V Operating Input Voltage Range
- Fixed 5V Output Voltage with Line Drop Compensation
- Accurate USB Output Current Limit
- 40mΩ/32mΩ Low $R_{DS(ON)}$ Internal Buck Power MOSFETs
- 24mΩ Low $R_{DS(ON)}$ Internal USB Power MOSFET
- 350kHz / 250kHz / 120kHz Frequency Selectable
- Frequency Dithering for 120kHz
- Programmable Line Drop Compensation
- Output Over-Voltage Protection (OVP)
- Hiccup Current Limit
- Supports DCP Scheme for BC1.2, Divider Mode, and 1.2V/1.2V Mode
- ±8kV HBM ESD Rating for USB, DP, and DM Pins
- Available in a QFN-25 (4mmx4mm) Package
- Available in AEC-Q100 Grade 1

APPLICATIONS

- Automotive USB Smart Charging Ports

All MPS parts are lead-free, halogen-free, and adhere to the RoHS directive. For MPS green status, please visit the MPS website under Quality Assurance. "MPS" and "The Future of Analog IC Technology" are registered trademarks of Monolithic Power Systems, Inc.

TYPICAL APPLICATION

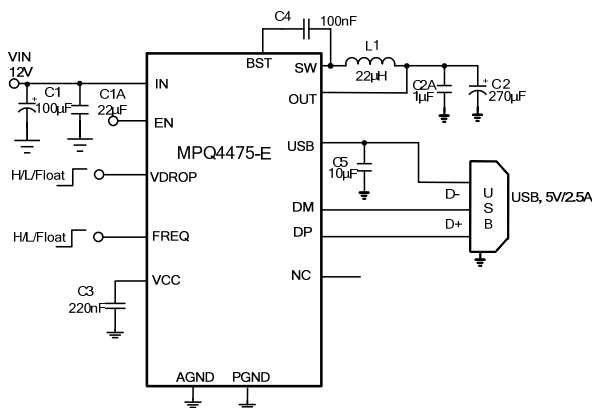

Efficiency vs. Load Current

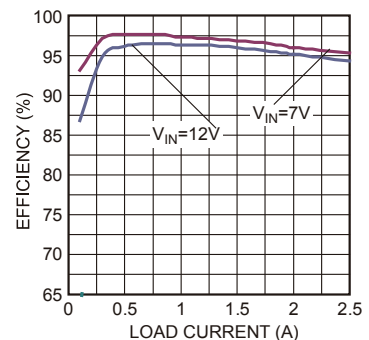

ORDERING INFORMATION

Part Number*	Package	Top Marking
MPQ4475GR-E-AEC1	QFN-25 (4mmx4mm)	See Below

* For Tape & Reel, add suffix -Z (e.g.: MPQ4475GR-E-AEC1-Z).

TOP MARKING

MPSYWW

MP4475

LLLLLL

E

MPS: MPS prefix
 Y: Year code
 WW: Week code
 MP4475: Product code of MPQ4475GR-E-AEC1
 LLLLLL: Lot number
 E: Enhanced

PACKAGE REFERENCE

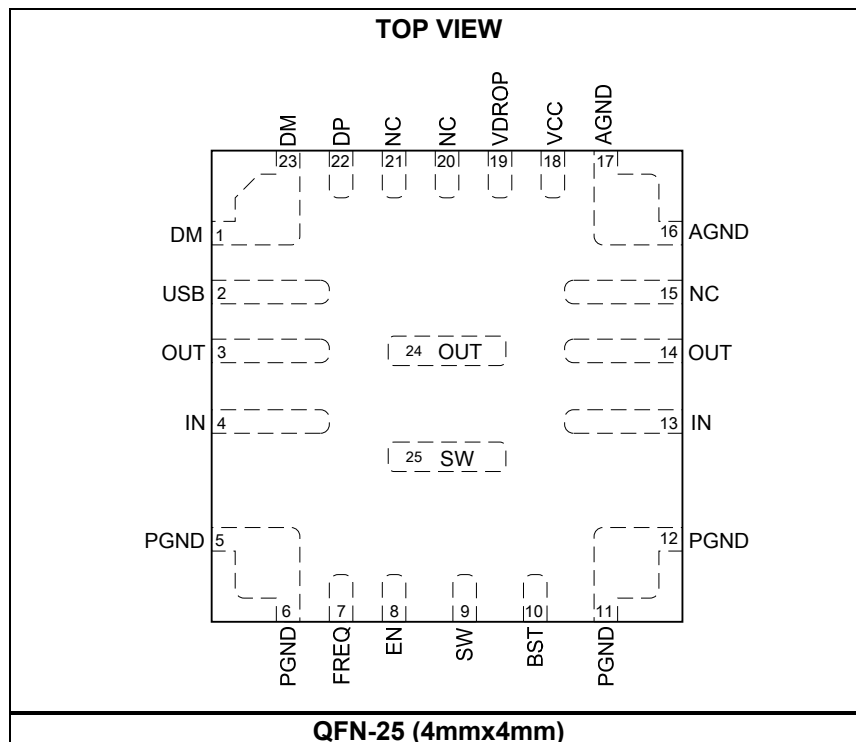

ABSOLUTE MAXIMUM RATINGS ⁽¹⁾

Supply voltage (V_{IN})	40V
V_{SW}	-0.3V (-5V for <10ns) to $V_{IN} + 0.3V$ (43V for <10ns)
V_{BST}	$V_{SW} + 6.5V$
V_{EN}	-0.3V to 10V ⁽²⁾
All other pins	-0.3V to +6.5V
Continuous power dissipation ($T_A = +25^\circ C$) ⁽³⁾	
QFN-25 (4mmx4mm)	2.8W
Junction temperature	150°C
Lead temperature	260°C
Storage temperature	-65°C to +150°C

Recommended Operating Conditions ⁽⁴⁾

Operation input voltage range	7V to 36V
Output current	2.5A for USB
Operating junction temp. (T_J)	-40°C to +125°C

Thermal Resistance ⁽⁵⁾	θ_{JA}	θ_{JC}
QFN-25 (4mmx4mm)	44	9

°C/W

NOTES:

- 1) Exceeding these ratings may damage the device.
- 2) For details on EN's ABS max rating, please refer to the EN Control section on page 11.
- 3) The maximum allowable power dissipation is a function of the maximum junction temperature T_J (MAX), the junction-to-ambient thermal resistance θ_{JA} , and the ambient temperature T_A . The maximum allowable continuous power dissipation at any ambient temperature is calculated by P_D (MAX) = $(T_J$ (MAX) - T_A) / θ_{JA} . Exceeding the maximum allowable power dissipation produces an excessive die temperature, causing the regulator to go into thermal shutdown. Internal thermal shutdown circuitry protects the device from permanent damage.
- 4) The device is not guaranteed to function outside of its operating conditions.
- 5) Measured on JESD51-7, 4-layer PCB.

ELECTRICAL CHARACTERISTICS

$V_{IN} = 12V$, $V_{EN} = 5V$, $T_J = -40^{\circ}C$ to $+125^{\circ}C$, typical value is tested at $T_J = +25^{\circ}C$, unless otherwise noted.

Parameter	Symbol	Condition	Min	Typ	Max	Units
Supply current (shutdown)	I_{IN}	$V_{EN} = 0V$, $T_J = +25^{\circ}C$			1	μA
		$V_{EN} = 0V$, $T_J = -40^{\circ}C$ to $+125^{\circ}C$			5	
Supply current (quiescent)	I_{Q_OL}	No switching		1.6	2.5	mA
EN rising threshold	V_{EN_Rising}		1.33	1.43	1.52	V
EN hysteresis	$V_{EN_Falling}$		110	140	170	mV
EN input current	I_{EN}	$V_{EN} = 2V$, $T_J = +25^{\circ}C$	1.1	1.8	2.5	μA
		$V_{EN} = 2V$, $T_J = -40^{\circ}C$ to $+125^{\circ}C$	0.8	1.8	3	
		$V_{EN} = 0V$		0		
Thermal shutdown ⁽⁶⁾	T_{STD}			165		$^{\circ}C$
Thermal hysteresis ⁽⁶⁾	T_{STD_HYS}			20		$^{\circ}C$
VCC regulator	V_{CC}		4.75	5.1	5.45	V
VCC load regulation	V_{CC_LOG}	$I_{CC} = 5mA$		1	2	%
Step-Down Converter						
V_{IN} under-voltage lockout threshold rising	V_{IN_UVLO}	$T_J = +25^{\circ}C$	5.2	5.7	6.2	V
V_{IN} under-voltage lockout threshold hysteresis	V_{UVLO_HYS}			1		V
HS switch on resistance	R_{DSON_HS}			40		m Ω
LS switch on resistance	R_{DSON_LS}			32		m Ω
Output voltage	V_{OUT}	$7V < V_{IN} < 36V$, no load, $T_J = +25^{\circ}C$	5	5.05	5.1	V
		$7V < V_{IN} < 36V$, no load, $T_J = -40^{\circ}C$ to $+125^{\circ}C$	4.95	5.05	5.15	
Output over-voltage protection	V_{OVP_R}		5.65	6	6.4	V
OVP recovery	V_{OVP_F}	$T_J = -40^{\circ}C$ to $+125^{\circ}C$	5.4	5.75	6.1	V
Switch leakage	SW_{LKG}	$V_{EN} = 0V$, $V_{SW} = 36V$, $T_J = +25^{\circ}C$			1	μA
		$V_{EN} = 0V$, $V_{SW} = 36V$, $T_J = -40^{\circ}C$ to $+125^{\circ}C$			5	
Current limit ⁽⁶⁾	I_{LIMIT}	Over 0 - 90% duty cycle	4			A
Oscillator frequency	f_{SW1}	FREQ = high, $T_J = +25^{\circ}C$	310	350	410	kHz
		FREQ = high, $T_J = -40^{\circ}C$ to $+125^{\circ}C$	300	350	420	
	f_{SW2}	FREQ = low, $T_J = +25^{\circ}C$	220	250	300	
		FREQ = low, $T_J = -40^{\circ}C$ to $+125^{\circ}C$	190	250	330	
	f_{SW3}	FREQ = float, $T_J = +25^{\circ}C$		120		
		FREQ = float, $T_J = -40^{\circ}C$ to $+125^{\circ}C$		120		
Maximum duty cycle	D_{MAX}	FREQ = 350kHz	84	88		%
Minimum on time ⁽⁶⁾	T_{ON_MIN}	$T_J = +25^{\circ}C$		130		ns
Soft-start time	t_{SS}	Output from 10% to 90%, $T_J = +25^{\circ}C$	1	1.65	2.3	ms
		Output from 10% to 90%, $T_J = -40^{\circ}C$ to $+125^{\circ}C$	0.9	1.65	2.4	

ELECTRICAL CHARACTERISTICS (continued)

$V_{IN} = 12V$, $V_{EN} = 5V$, $T_J = -40^{\circ}C$ to $+125^{\circ}C$, typical value is tested at $T_J = +25^{\circ}C$, unless otherwise noted.

Parameter	Symbol	Condition	Min	Typ	Max	Units
USB Switch						
Under-voltage lockout threshold rising	V_{USB_UVR}	$T_J = +25^{\circ}C$	3.8	4	4.3	V
		$T_J = -40^{\circ}C$ to $+125^{\circ}C$	3.75	4	4.33	
Under-voltage lockout threshold hysteresis	V_{USB_UVHYS}		220	270	320	mV
Switch on resistance	R_{DSON_SW}			24		m Ω
Current limit	I_{Limit}	$T_J = +25^{\circ}C$	2.6	2.75	2.9	A
Line drop compensation	V_{DROP_COM1}	Max load 2.4A, $V_{DROP} = \text{float}$, $T_J = +25^{\circ}C$	300	400	500	mV
	V_{DROP_COM2}	Max load 2.4A, $V_{DROP} = \text{high}$		280		mV
	V_{DROP_COM3}	Max load 2.4A, $V_{DROP} = \text{GND}$		130		mV
FREQ, VDROPP high level	V_{HIGH}		$V_{CC} - 0.4V$			V
FREQ, VDROPP middle level	V_{MIDDLE}			2.5		V
FREQ, VDROPP low level	V_{LOW}				0.4	V
V_{BUS} soft-start time	T_{SS}	$V_{OUT} = 5V$, from 10% to 90%, $T_J = +25^{\circ}C$	1	1.6	2.2	ms
		$V_{OUT} = 5V$, from 10% to 90%, $T_J = -40^{\circ}C$ to $+125^{\circ}C$	0.9	1.6	2.4	
Discharge resistance	R_{DCHG}	$T_J = +25^{\circ}C$		50	70	Ω
		$T_J = -40^{\circ}C$ to $+125^{\circ}C$		50	75	
On time of hiccup mode	T_{HICP_ON1}	$V_{OUT} = 5V$, V_{BUS} connected to GND		2 ⁽⁶⁾		ms
	T_{HICP_ON2}	$V_{OUT} = 5V$, $V_{BUS} > 4V$, OC, $T_J = +25^{\circ}C$	3.5	5	6.5	
			$V_{OUT} = 5V$, $V_{BUS} > 4V$, OC, $T_J = -40^{\circ}C$ to $+125^{\circ}C$	3	5	7
Off time of hiccup mode	T_{HICP_OFF}	$V_{OUT} = 5V$, V_{BUS} connected to GND, $T_J = +25^{\circ}C$	0.35	0.5	0.65	s
		$V_{OUT} = 5V$, V_{BUS} connected to GND, $T_J = -40^{\circ}C$ to $+125^{\circ}C$	0.2	0.5	0.8	
BC1.2 DCP Mode						
DP and DM short resistance	R_{DP/DM_Short}	$V_{DP} = 0.8V$, $I_{DM} = 1mA$, $T_J = +25^{\circ}C$		125	155	Ω
		$V_{DP} = 0.8V$, $I_{DM} = 1mA$, $T_J = -40^{\circ}C$ to $+125^{\circ}C$		125	160	
Divider Mode						
DP/DM output voltage	$V_{DP/DM_Divider}$	$V_{OUT} = 5V$, $T_J = +25^{\circ}C$	2.54	2.7	2.82	V
		$V_{OUT} = 5V$, $T_J = -40^{\circ}C$ to $+125^{\circ}C$	2.5	2.7	2.85	
DP/DM output impedance	$R_{DP/DM_Divider}$	$T_J = +25^{\circ}C$	16	22	30	k Ω
		$T_J = -40^{\circ}C$ to $+125^{\circ}C$	14	22	34	

ELECTRICAL CHARACTERISTICS (continued)

$V_{IN} = 12V$, $V_{EN} = 5V$, $T_J = -40^{\circ}C$ to $+125^{\circ}C$, typical value is tested at $T_J = +25^{\circ}C$, unless otherwise noted.

Parameter	Symbol	Condition	Min	Typ	Max	Units
1.2V/1.2V Mode						
DP/DM output voltage	$V_{DP/DM_1.2V}$	$V_{OUT} = 5V$, $T_J = +25^{\circ}C$	1.16	1.25	1.34	V
		$V_{OUT} = 5V$, $T_J = -40^{\circ}C$ to $+125^{\circ}C$	1.15	1.25	1.35	
DP/DM output impedance	$R_{DP/DM_1.2V}$	$T_J = +25^{\circ}C$	75	96	115	k Ω
		$T_J = -40^{\circ}C$ to $+125^{\circ}C$	70	96	130	

NOTE:

6) Guaranteed by design.

TYPICAL PERFORMANCE CHARACTERISTICS

$V_{IN} = 12V$, $V_{OUT} = 5V$, $L = 22\mu H$, $f_{SW} = 250kHz$, $T_A = 25^\circ C$, unless otherwise noted.

Line Drop Compensation vs. Load Current

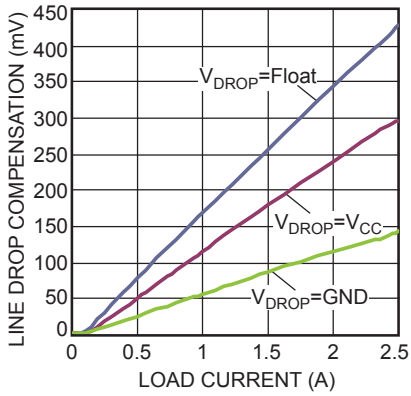

Efficiency vs. Load Current

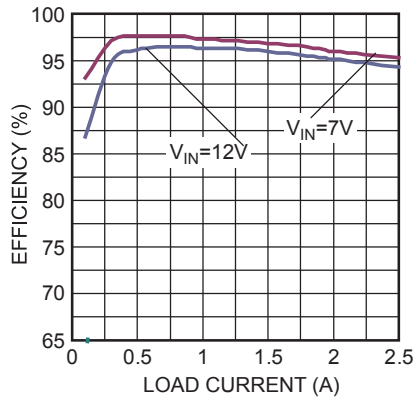

Thermal Test

2 Layer PCB, 4.78cm x 1.38cm
 $T_A=25^\circ C$, No Airflow
 $V_{IN}=12V$, $USB_I_{OUT}=1.1A$

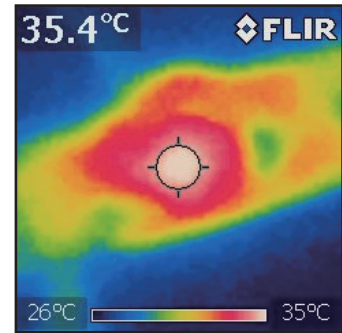

Thermal Test

2 Layer PCB, 4.78cm x 1.38cm
 $T_A=25^\circ C$, No Airflow
 $V_{IN}=12V$, $USB_I_{OUT}=2.5A$

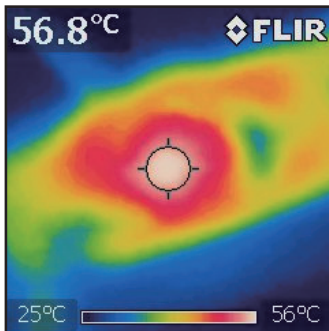

TYPICAL PERFORMANCE CHARACTERISTICS (continued)
 $V_{IN} = 12V, V_{OUT} = 5V, L = 22\mu H, f_{SW} = 250kHz, T_A = 25^\circ C$, unless otherwise noted.

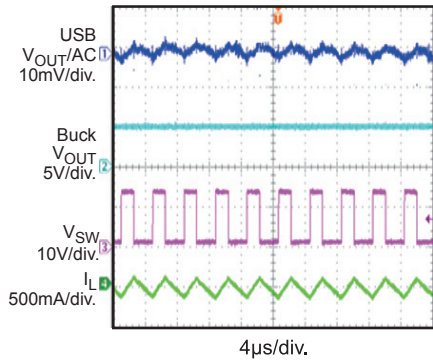
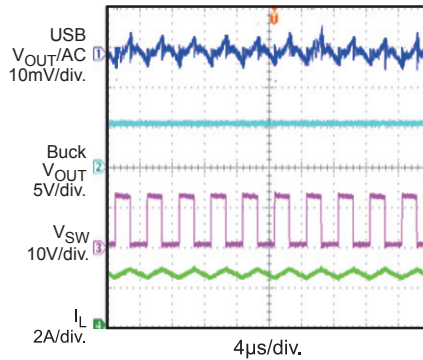
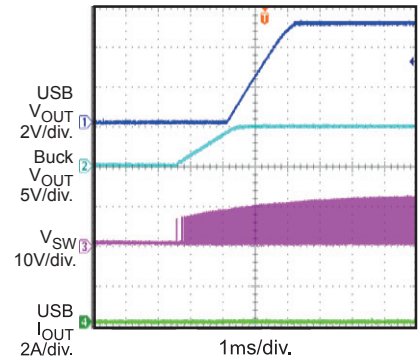
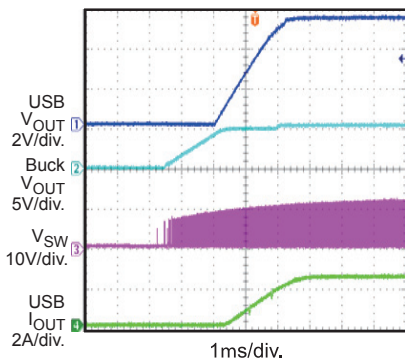
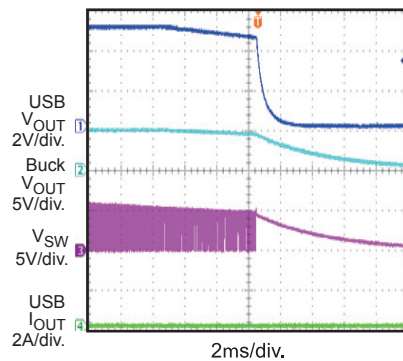
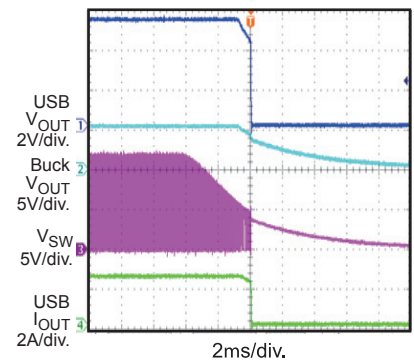
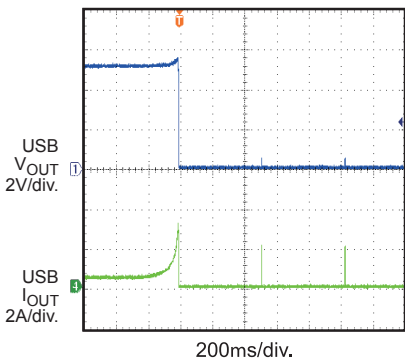
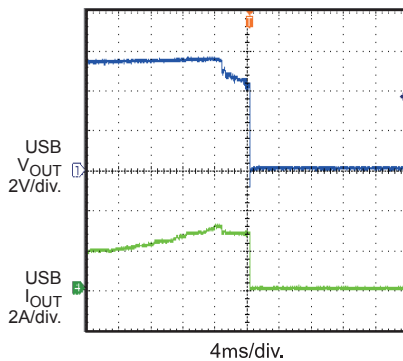
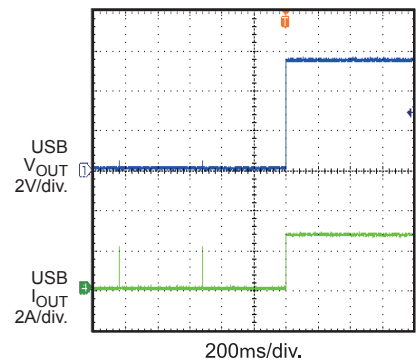
Output Ripple
 $V_{IN} = 12V, USB_I_{OUT} = 0A$

Output Ripple
 $V_{IN} = 12V, USB_I_{OUT} = 2.5A$

Power Start-Up
 $V_{IN} = 12V, USB_I_{OUT} = 0A$

Power Start-Up
 $V_{IN} = 12V, USB_I_{OUT} = 2.5A$,
CRL Load

Power Shutdown
 $V_{IN} = 12V, USB_I_{OUT} = 0A$

Power Shutdown
 $V_{IN} = 12V, USB_I_{OUT} = 2.5A$,
CRL Load

USB Over-Current Protection Entry

USB Over-Current Protection Entry

USB Over-Current Protection Recovery

PIN FUNCTIONS

QFN 4x4 Pin #	Name	Description
1, 23	DM	D- data line to USB connector. DM is the input/output used for handshaking with portable devices.
2	USB	USB output.
3, 14, 24	OUT	Buck output. OUT is the power input of the USB. The internal circuit senses the OUT voltage and regulates it at 5V.
4, 13	IN	Supply voltage. IN is the drain of the internal power device and supplies power to the entire chip. The MPQ4475-E operates with a 7 - 36V input voltage range. A capacitor (C_{IN}) is needed to prevent large voltage spikes at the input. Place C_{IN} as close to the IC as possible.
5, 6, 11, 12	PGND	Power ground. PGND is the reference ground of the regulated output voltage and requires extra care during the PCB layout. Connect PGND to GND with copper traces and vias.
7	FREQ	Frequency selection. Float FREQ to set the frequency at 120kHz with dithering. Pull FREQ to ground to set the frequency at 250kHz. Pull FREQ high to set the frequency at 350kHz.
8	EN	On/off control input.
9, 25	SW	Switch output. Connect SW using wide PCB traces.
10	BST	Bootstrap. Connect a 0.1 μ F capacitor between SW and BST to form a floating supply across the high-side switch driver.
15	NC	No connection. NC (pin 15) can be connected to OUT for better thermal dissipation.
16, 17	AGND	Analog ground. Connect AGND to PGND.
18	VCC	Internal 5V LDO regulator output. Decouple VCC with a 0.22 μ F capacitor.
19	VDROP	Line drop compensation selection. Refer to the EC table on page 5 for detailed specifications.
20, 21	NC	No connection. NC (pin 20, 21) must be left floating.
22	DP	D+ data line to USB connector. DP is the input/output used for handshaking with portable devices.

BLOCK DIAGRAM

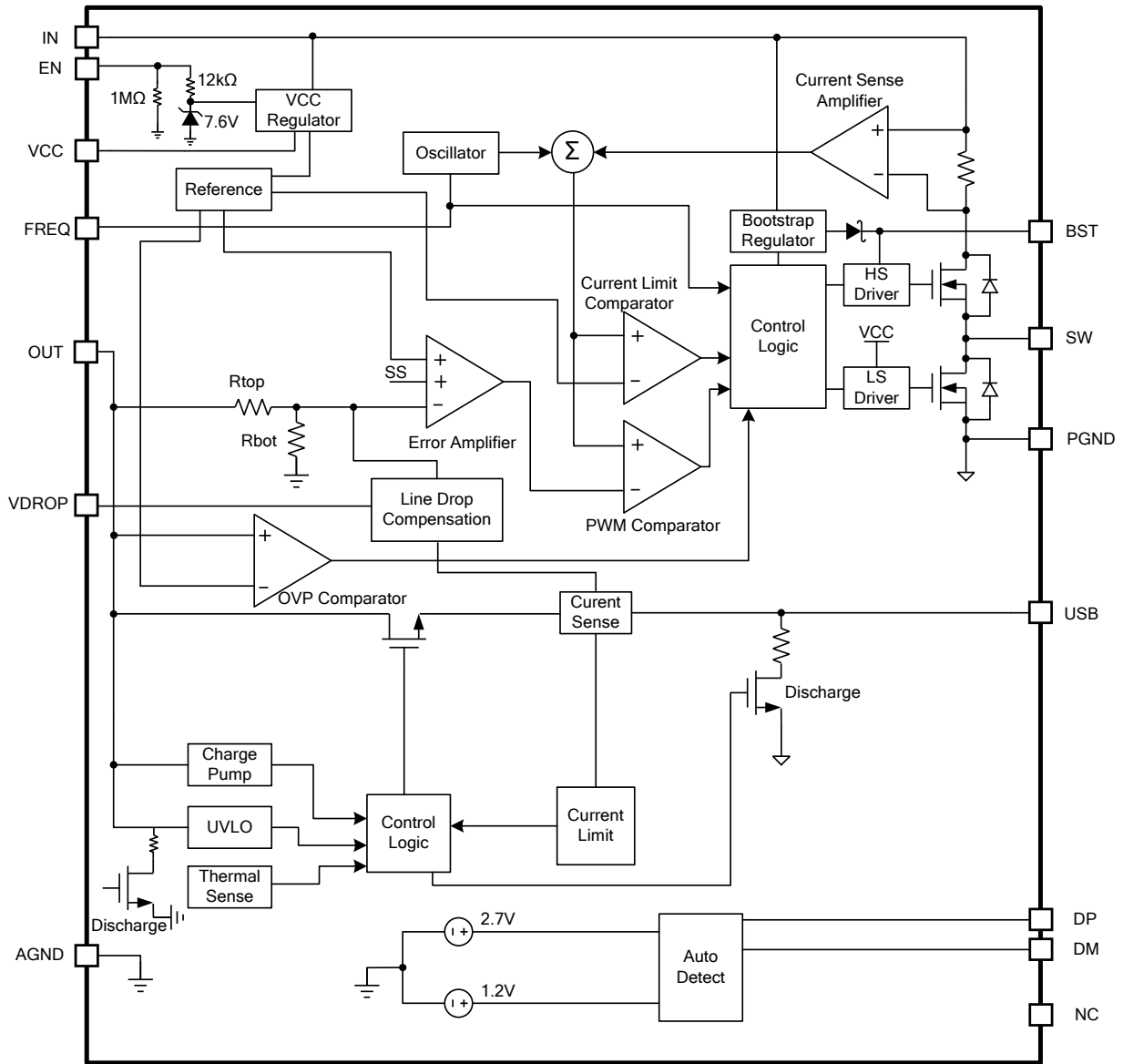

Figure 1: Functional Block Diagram

OPERATION

BUCK CONVERTER SECTION

The MPQ4475-E integrates a monolithic, synchronous, rectified, step-down, switch-mode converter with internal power MOSFETs and a USB current-limit switch with charging port auto-detection. The MPQ4475-E offers a very compact solution that achieves 2.5A of continuous output current with excellent load and line regulation over a wide input supply range.

The MPQ4475-E operates in a fixed-frequency, peak-current-mode control to regulate the output voltage. The internal clock initiates the pulse-width modulation (PWM) cycle, which turns on the integrated high-side power MOSFET (HS-FET). The HS-FET turns on and remains on until its current reaches the value set by the COMP voltage (V_{COMP}). If the power switch is off, it remains off until the next clock cycle begins. If the duty cycle reaches 88% (350kHz switching frequency) in one PWM period, the current in the power MOSFET cannot reach the value set by V_{COMP} , and the power MOSFET turns off.

Error Amplifier (EA)

The error amplifier (EA) compares the internal feedback voltage (V_{FB}) against the internal 1V reference (REF) and outputs a V_{COMP} value, which controls the power MOSFET current. The optimized internal compensation network minimizes the external component count and simplifies the control loop design.

Internal VCC Regulator

The 5V internal regulator powers most of the internal circuitries. This regulator takes the V_{IN} input and operates in the full V_{IN} range. When V_{IN} is greater than 5.0V, the output of the regulator is in full regulation. When V_{IN} is lower than 5.0V, the output voltage decreases with V_{IN} . VCC requires an external 0.22 μ F ceramic capacitor for decoupling.

Enable Control (EN)

The MPQ4475-E has an enable control pin (EN). Pull EN high to enable the IC. Pull EN low to disable the IC. Connect EN to V_{IN} through a resistor for automatic start-up. An internal 1M Ω resistor connected from EN to GND allows EN

to be floated to shut down the IC. EN is clamped internally using a 7.6V series Zener diode (see Figure 2). Connecting the EN input through a pull-up resistor to any voltage on V_{IN} limits the EN input current below 230 μ A and the amplitude of the voltage source below 10V to prevent damage to the Zener diode. For example, if 36V is connected to V_{IN} , then $R_{PULLUP} \geq (36V - 10V) / 230\mu A = 113k\Omega$.

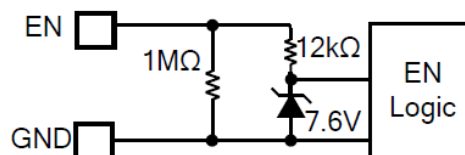

Figure 2: Zener Diode between EN and GND

Under-Voltage Lockout (UVLO)

Under-voltage lockout (UVLO) protects the chip from operating with an insufficient supply voltage. The UVLO comparator monitors the input voltage. The UVLO rising threshold is 5.7V, and its falling threshold is 4.7V.

Internal Soft Start (SS)

Soft start prevents the converter output voltage from overshooting during start-up. When the chip starts up, the internal circuitry generates a soft-start voltage (SS) that ramps up from 0V to 5V. When SS is lower than REF, the error amplifier uses SS as the reference. When SS is higher than REF, the error amplifier uses REF as the reference. The SS time is set to 1.65ms internally.

If the output of the MPQ4475-E is pre-biased to a certain voltage during start-up, the IC disables the switching of both the high-side and low-side switches until the voltage on the internal soft-start capacitor exceeds the internal feedback voltage.

Buck Over-Current-Protection (OCP)

The MPQ4475-E uses a cycle-by-cycle over-current limit when the inductor peak current exceeds the current-limit threshold, and V_{FB} drops below the under-voltage (UV) threshold (typically 70% below the reference). Once UV is triggered, the MPQ4475-E enters hiccup mode to restart the part periodically. This protection mode is especially useful when the output is dead-short-circuited to ground. The average short-circuit current is reduced greatly to alleviate

thermal issues and protects the regulator. The MPQ4475-E exits hiccup mode once the over-current condition is removed.

Buck Output Over-Voltage Protection (OVP)

The MPQ4475-E buck converter has output over-voltage protection (OVP). If the output is higher than 6V, the high-side switch stops turning on, and the low-side switch turns on to discharge the output voltage until the output decreases to 5.75V. The chip then resumes normal operation.

If the output over-voltage cannot be discharged to 5.75V, the low-side switch is turned off after the inductor current reaches a negative current limit. The low-side switch turns on again when the next clock is triggered.

Frequency Dithering

When $FREQ$ is floated, the buck switching frequency is set to 120kHz. The MPQ4475-E has a frequency spread spectrum modulation. A triangular waveform is used to modulate the frequency. This can help improve EMC performance.

Floating Driver and Bootstrap Charging

An external bootstrap capacitor powers the floating power MOSFET driver. This floating driver has its own UVLO protection. The UVLO's rising threshold is 2.2V with a hysteresis of 150mV. The bootstrap capacitor voltage is regulated internally by V_{IN} through D1, M1, C4, L1, and C2 (see Figure 3). If $V_{BST} - V_{SW}$ exceeds 5V, U1 regulates M1 to maintain a 5V BST voltage across C4.

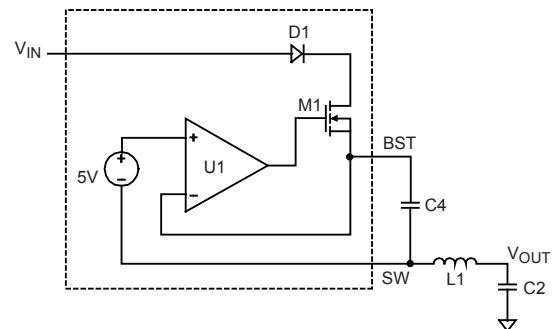

Figure 3: Internal Bootstrap Charging Circuit

Start-Up and Shutdown

If both V_{IN} and EN exceed their respective thresholds, the chip is enabled. The reference block starts first, generating a stable reference voltage and current, and then the internal regulator is enabled. The regulator provides a stable supply for the remaining circuitries.

Several events can shut down the chip: EN low, V_{IN} low, and thermal shutdown. During the shutdown procedure, the signaling path is blocked first to avoid any fault triggering. V_{COMP} and the internal supply rail are then pulled down. The floating driver is not subject to this shutdown command.

Buck Output Discharge

The buck portion involves a discharge function that provides a resistive discharge path for the external output capacitor. The function is active when the part is disabled (input voltage is under UVLO, enable off), and is done in a very limited amount of time. After V_{CC} is discharged below 1V, the buck output discharge resistor is disconnected.

USB CURRENT-LIMIT SWITCH PORTION

Current-Limit Switch

The MPQ4475-E integrates a single-channel USB current-limit switch that provides built-in, soft-start circuitry that controls the rising slew rate of the output voltage to limit inrush current and voltage surges.

When the load current reaches the current-limit threshold (typically 2.75A), the USB power MOSFET switches into a foldback current limit mode (70% of the current limit) (see Figure 4). If the over-current limit condition lasts longer than 5ms, the chip enters hiccup mode with 5ms of on time and 0.5s of off time.

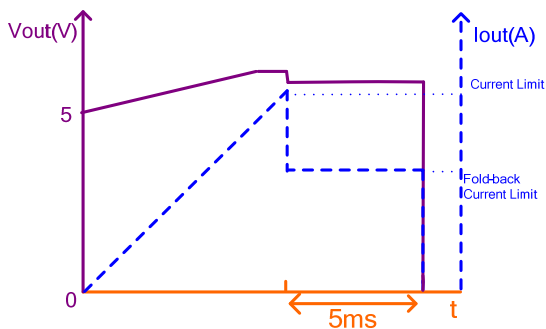

Figure 4: Over-Current Limit

After the soft start finishes, if there is an output under-voltage ($V_{USB} < 4V$) that lasts longer than $50\mu s$, the MPQ4475-E enters hiccup mode (see Figure 5). This prevents an abnormal thermal rise during the constant resistor (CR) load over-current case.

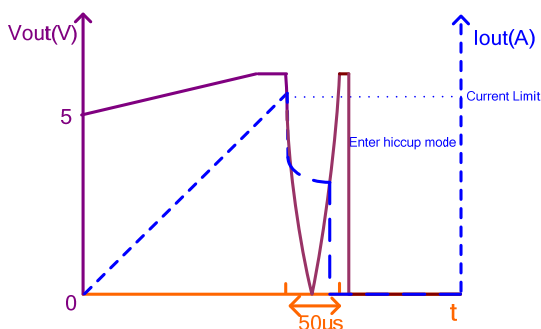

Figure 5: Over-Current Protection

Output Line Drop Compensation

The MPQ4475-E can compensate for an output-voltage drop, such as high impedance caused by a long trace, to maintain a fairly constant 5V load-side voltage.

The MPQ4475-E uses the internal current-sense output voltage of the current-limit switch to compensate for the line drop voltage. Since the trace resistance is different for different cables, the MPQ4475-E provides selectable line drop compensation through VDROPP. The line drop compensation amplitude increases linearly as the load current increases and also has an upper limitation.

USB Output Over-Voltage Protection (OVP)

To protect the device at the cable terminal, the USB switch output uses a dynamic over-voltage protection (OVP) threshold. The MPQ4475-E adjusts the OVP threshold based on different USB loading currents.

The MPQ4475-E uses an intelligent line drop compensation and dynamic OVP control scheme to ensure that the voltage at the cable terminal meets the 4.75 - 5.25V specification.

USB Output Discharge

Each USB portion involves a discharge function that provides a resistive discharge path for the external output capacitor. The function is active when the part is disabled (input voltage is under UVLO, enable off) and is done in a very limited amount of time.

Auto-Detection

The MPQ4475-E integrates a USB-dedicated charging port auto-detect function that can recognize most mainstream portable devices. It supports the following charging schemes:

- USB battery charging specification BC1.2/ Chinese Telecommunications Industry Standard YD/T 1591-2009
- Divider mode
- 1.2V/1.2V mode

The auto-detect function utilizes a state machine that supports all of the DCP charging schemes above.

Thermal Shutdown

Thermal shutdown prevents the chip from operating at exceedingly high temperatures. When the silicon die temperature exceeds $165^{\circ}C$, the entire chip shuts down. When the temperature falls below its lower threshold (typically $145^{\circ}C$), the chip is enabled again.

APPLICATION INFORMATION

Selecting the Inductor

For most applications, use an inductor with a DC current rating at least 25% higher than the maximum load current. Select an inductor with a small DC resistance for optimum efficiency. For most designs, the inductor value can be derived with Equation (1):

$$L_1 = \frac{V_{OUT} \times (V_{IN} - V_{OUT})}{V_{IN} \times \Delta I_L \times f_{OSC}} \quad (1)$$

Where ΔI_L is the inductor ripple current.

Choose the inductor ripple current to be approximately 30% of the maximum load current. The maximum inductor peak current can be calculated with Equation (2):

$$I_{L(MAX)} = I_{LOAD} + \frac{\Delta I_L}{2} \quad (2)$$

A 22 μ H inductance is recommended to improve EMI.

Selecting the Buck Input Capacitor

The input current to the step-down converter is discontinuous and therefore requires a capacitor to supply AC current while maintaining the DC input voltage. For the best performance, use low ESR capacitors. Ceramic capacitors with X5R or X7R dielectrics are highly recommended because of their low ESR and small temperature coefficients. For CLA applications, a low ESR 100 μ F electrolytic capacitor and two 10 μ F ceramic capacitors are recommended for EMI reduction.

Since the input capacitor (C1) absorbs the input switching current, it requires an adequate ripple current rating. The RMS current in the input capacitor can be estimated with Equation (3):

$$I_{C1} = I_{LOAD} \times \sqrt{\frac{V_{OUT}}{V_{IN}} \times \left(1 - \frac{V_{OUT}}{V_{IN}}\right)} \quad (3)$$

The worst-case condition occurs at $V_{IN} = 2V_{OUT}$, shown in Equation (4):

$$I_{C1} = \frac{I_{LOAD}}{2} \quad (4)$$

For simplification, choose an input capacitor with an RMS current rating greater than half of the maximum load current. The input capacitor can be electrolytic, tantalum, or ceramic. When using electrolytic capacitors, add two high-quality ceramic capacitors as close to IN as possible. The input voltage ripple caused by the capacitance can be estimated with Equation (5):

$$\Delta V_{IN} = \frac{I_{LOAD}}{f_s \times C1} \times \frac{V_{OUT}}{V_{IN}} \times \left(1 - \frac{V_{OUT}}{V_{IN}}\right) \quad (5)$$

Selecting the Buck Output Capacitor

The device requires an output capacitor (C2) to maintain the DC output voltage. Estimate the output voltage ripple with Equation (6):

$$\Delta V_{OUT} = \frac{V_{OUT}}{f_s \times L_1} \times \left(1 - \frac{V_{OUT}}{V_{IN}}\right) \times \left(R_{ESR} + \frac{1}{8 \times f_s \times C2}\right) \quad (6)$$

Where L_1 is the inductor value, and R_{ESR} is the equivalent series resistance (ESR) value of the output capacitor.

For electrolytic capacitors, the ESR dominates the impedance at the switching frequency. For simplification, the output ripple can be approximated with Equation (7):

$$\Delta V_{OUT} = \frac{V_{OUT}}{f_s \times L_1} \times \left(1 - \frac{V_{OUT}}{V_{IN}}\right) \times R_{ESR} \quad (7)$$

The characteristics of the output capacitor affect the stability of the regulatory system. A low ESR electrolytic capacitor is recommended for its low output ripple and good control loop stability. For CLA applications, a 1 μ F ceramic capacitor and a 270 μ F polymer or electrolytic capacitor with ~20m Ω ESR are recommended.

PCB Layout Guidelines

Efficient PCB layout is critical for stable operation and thermal dissipation. For best results, refer to Figure 6 and follow the guidelines below.

1. Connect OUT with short, direct, and wide traces.
2. Add vias under the IC.
3. Route the OUT trace on both PCB layers.
4. Use a large copper plane for PGND.
5. Add multiple vias for better thermal dissipation.
6. Connect AGND to PGND.
7. Use a large copper plane for SW and USB.
8. Place the USB output capacitor close to USB.
9. Place two ceramic input decoupling capacitors as close to IN and PGND as possible to improve EMI performance.
10. Place the VCC decoupling capacitor as close to VCC as possible.

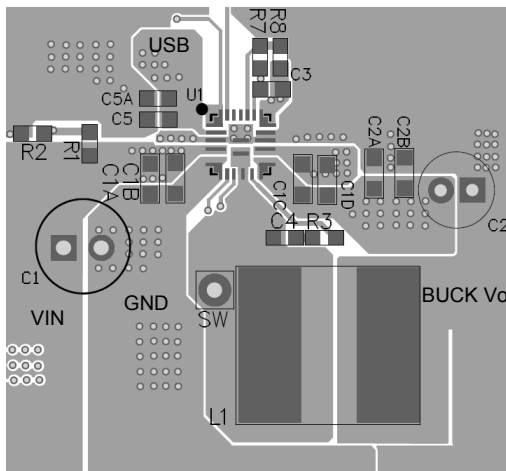

Top Layer

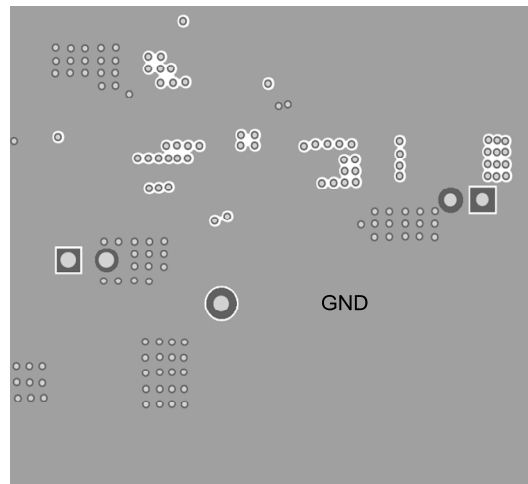

Mid Layer 1

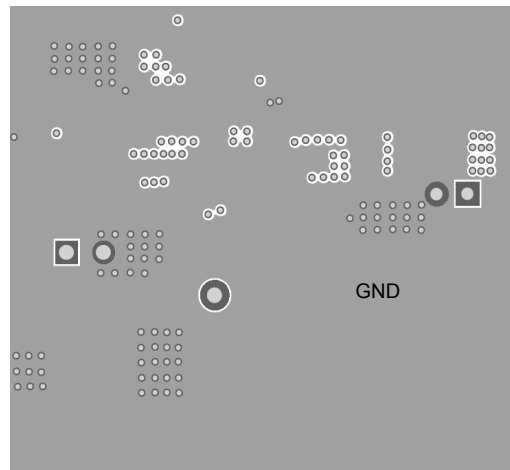

Mid Layer 2

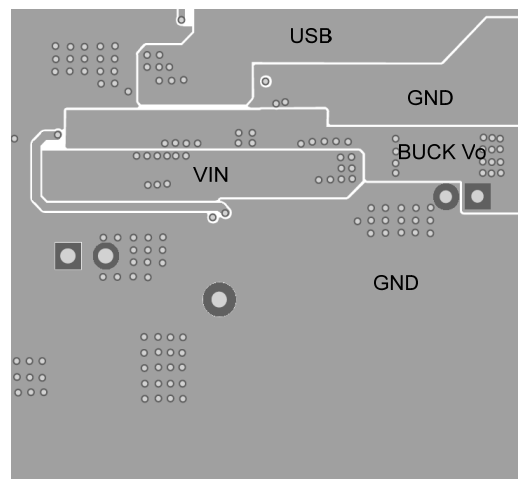

Bottom Layer

Figure 6: Recommended Layout

TYPICAL APPLICATION CIRCUIT
