



MPQ4488T

36V, 6A, Step-Down Converter with Programmable Frequency and Spread Spectrum Option, Dual USB Charging Ports, 135°C Load-Shedding Temp AEC-Q100 Qualified

DESCRIPTION

The MPQ4488T integrates a monolithic, step-down, switch-mode converter with two USB current-limit switches and charging port identification circuitry for each port. The MPQ4488T achieves 6A of output current with excellent load and line regulation over a wide input supply range.

The output of each USB switch is current-limited. Both USB ports support DCP schemes for battery charging specification (BC 1.2), divider mode, 1.2V/1.2V mode, and USB Type-C 5V @ 3A DFP mode, eliminating the need for outside user interaction.

Full protection features include hiccup current limiting, output over-voltage protection (OVP), and thermal shutdown.

The MPQ4488T requires a minimal number of readily available, standard, external components and is available in a QFN-26 (5mmx5mm) package.

FEATURES

- Wide 6V to 36V Operating Input Voltage Range
- Selectable Output Voltage: 5.1V, 5.17V, and 5.3V
- 90mV Line Drop Compensation
- Accurate USB1/USB2 Output Current Limit
- 18mΩ/15mΩ Low $R_{DS(ON)}$ Internal Buck Power MOSFETs
- 13mΩ/13mΩ Low $R_{DS(ON)}$ Internal USB1/USB2 Power MOSFETs
- Frequency Adjustable (250kHz to 2.2MHz)
- Frequency Spread Spectrum for MPQ4488TGU-FD-AEC1/MPQ4488TGU-FD2-AEC1
- Forced Continuous Conduction Mode (CCM) Operation
- 135°C Load Shedding Entry Temperature
- Hiccup Current Limit for both Buck and USB
- Supports DCP Schemes for BC1.2, Divider Mode, and 1.2V/1.2V Mode
- Supports USB Type-C 5V @ 3A DFP Mode
- ±8kV HBM ESD Rating for USB, DP, and DM Pins
- Available in a QFN-26 (5mmx5mm) Package
- Available in AEC-Q100 Grade 1

APPLICATIONS

- USB Dedicated Charging Ports (DCP)
- USB Type-C Charging Ports

All MPS parts are lead-free, halogen-free, and adhere to the RoHS directive. For MPS green status, please visit the MPS website under Quality Assurance. "MPS", the MPS logo, and "Simple, Easy Solutions" are trademarks of Monolithic Power Systems, Inc. or its subsidiaries.

TYPICAL APPLICATION

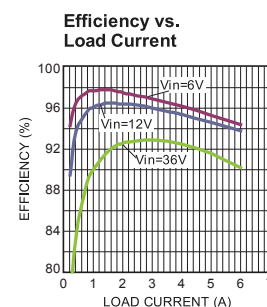
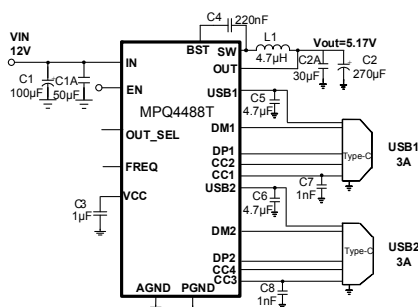

ORDERING INFORMATION

Part Number	Package	Top Marking	MSL Rating
MPQ4488TGU-AEC1*	QFN-26 (5mmx5mm)	See Below	1
MPQ4488TGU-FD-AEC1**			
MPQ4488TGU-FD2-AEC1***			

* For Tape & Reel, add suffix -Z (e.g.: MPQ4488TGU-AEC1-Z)

** For Tape & Reel, add suffix -Z (e.g.: MPQ4488TGU-FD-AEC1-Z)

***For Tape & Reel, add suffix -Z (e.g.: MPQ4488TGU-FD2-AEC1-Z)

DEVICE COMPARISON INFORMATION

Part Number	Frequency Spread Spectrum
MPQ4488TGU-AEC1	No
MPQ4488TGU-FD-AEC1	Yes, fundamental fs is 450kHz
MPQ4488TGU-FD2-AEC1	Yes, fundamental fs is 250kHz

TOP MARKING

MPSYYWW

MP4488

LLLLLLL

MPS: MPS prefix

YY: Year code

WW: Week code

MP4488: part number

LLLLLLL: Lot number

Note: Above top marking is for MPQ4488T and MPQ4488T-FD2.

MPSYYWW

MP4488T

LLLLLLL

FD

MPS: MPS prefix

YY: Year code

WW: Week code

MP4488T: part number

LLLLLLL: Lot number

FD: Part number suffix

Note: Above top marking is for MPQ4488T-FD.

PACKAGE REFERENCE

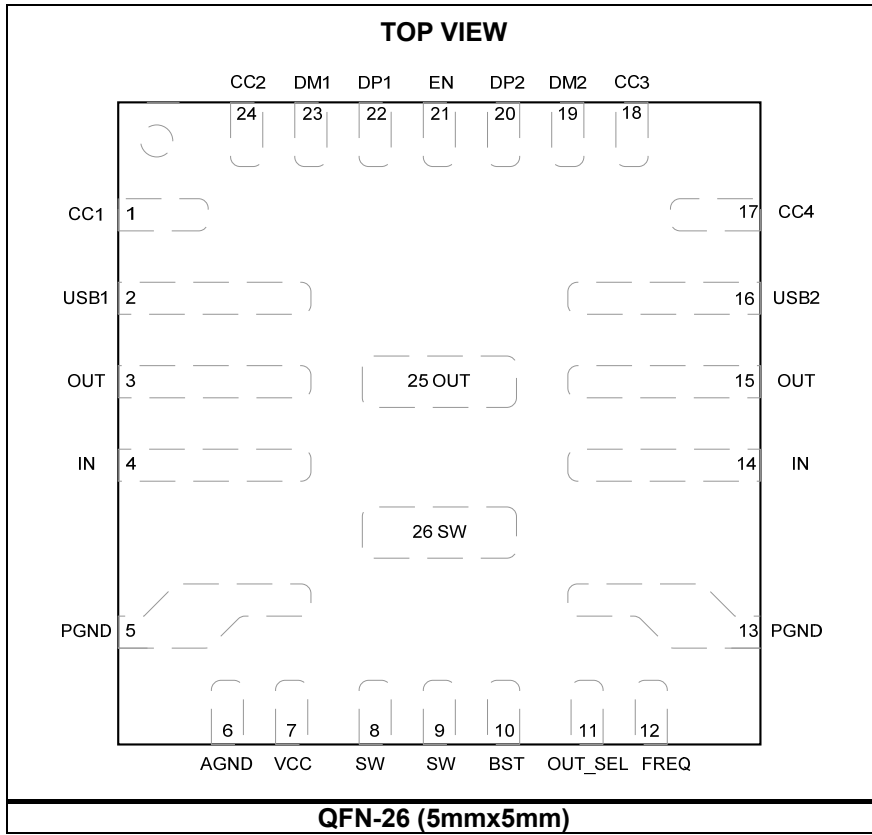

PIN FUNCTIONS

QFN 5x5 Pin #	Name	Description
1	CC1	Configuration channel. CC1 is used to detect connections and configure the interface across the USB1 Type-C cables and connectors. Once a connection is established, CC1 or CC2 is reassigned to provide power over the VCONN pin of the plug.
2	USB1	USB1 output.
3, 15, 25	OUT	Buck output. OUT is the power input for USB1 and USB2.
4, 14	IN	Supply voltage. IN is the drain of the internal power device and provides power to the entire chip. The MPQ4488T operates from a 6 - 36V input voltage. An input capacitor (C_{IN}) prevents large voltage spikes from appearing at the input. Place C_{IN} as close to the IC as possible.
5, 13	PGND	Power ground. PGND is the reference ground of the regulated output voltage. PGND requires extra care during the PCB layout. Connect PGND with copper traces and vias.
6	AGND	Analog ground. Connect AGND to PGND.
7	VCC	Internal 4.5V LDO regulator output. Decouple VCC with a 1 μ F capacitor.
8, 9, 26	SW	Switch output. Use a wide PCB trace to make the connection.
10	BST	Bootstrap. A 0.22 μ F capacitor is connected between SW and BST to form a floating supply across the high-side switch driver.
11	OUT_SEL	Buck output voltage set. Setting OUT_SEL to a low, floating, or high connection can set three different output voltages: 5.1V, 5.17V, or 5.3V.
12	FREQ	Switching frequency program input. Connect a resistor from FREQ to GND to set the switching frequency. Float FREQ or connect FREQ to VCC for the default 450kHz frequency. Connect FREQ to ground for a 250kHz internal frequency. For the MPQ4488TGU-FD-AEC1, float FREQ or connect FREQ to VCC to achieve a $\pm 10\%$ frequency spread spectrum based on 450kHz. Connect a resistor from FREQ to GND or pull FREQ to GND to set the switching frequency without a frequency spread spectrum. For the MPQ4488TGU-FD2-AEC1, float FREQ or connect FREQ to VCC to achieve a $\pm 10\%$ frequency spread spectrum based on 250KHz. Connect a resistor from FREQ to GND or pull FREQ to GND to set the switching frequency without a frequency spread spectrum.
16	USB2	USB2 output.
17	CC4	Configuration channel. CC4 is used to detect connections and configure the interface across the USB2 Type-C cables and connectors. Once a connection is established, CC3 or CC4 is reassigned to provide power over the VCONN pin of the plug.
18	CC3	Configuration channel. CC3 is used to detect connections and configure the interface across the USB2 Type-C cables and connectors. Once a connection is established, CC3 or CC4 is reassigned to provide power over the VCONN pin of the plug.
19	DM2	D- data line to USB2 connector. DM2 is the input/output used for handshaking with portable devices.
20	DP2	D+ data line to USB2 connector. DP2 is the input/output used for handshaking with portable devices.
21	EN	On/off control input. EN has an internal auto pull-up with an 8 μ A current source.
22	DP1	D+ data line to USB1 connector. DP1 is the input/output used for handshaking with portable devices.
23	DM1	D- data line to USB1 connector. DM1 is the input/output used for handshaking with portable devices.

PIN FUNCTIONS (continued)

QFN 5x5 Pin #	Name	Description
24	CC2	Configuration channel. CC2 is used to detect connections and configure the interface across the USB1 Type-C cables and connectors. Once a connection is established, CC1 or CC2 is reassigned to provide power over the VCONN pin of the plug.

ABSOLUTE MAXIMUM RATINGS (1)

Supply voltage (V_{IN})	-0.4V to +40V
V_{SW}	-0.3V (-5V for <10ns) to $V_{IN} + 0.3V$ (43V for <10ns)
V_{BST}	$V_{SW} + 5.5V$
V_{EN}	-0.3V to +10V (2)
V_{OUT}, V_{USB}	-0.3V to +6.5V
All other pins	-0.3V to +5.5V
Continuous power dissipation ($T_A = +25^\circ C$) (3) (8)	
QFN-26 (5mmx5mm)	6.25W
Junction temperature	150°C
Lead temperature	260°C
Storage temperature	-65°C to +150°C

ESD Rating (4)

CC1/CC2/CC3/CC4 (HBM) (5)	$\pm 5.5kV$
DP1/DP2/DM1/DM2/USB1/USB2 (HBM) (5)	$\pm 8kV$
All other pins (HBM)	$\pm 2kV$
All pins (CDM)	$\pm 750V$

Recommended Operating Conditions (6)

Operation input voltage range	6V to 36V
Output current	3A for USB1, 3A for USB2
Operating junction temp. (T_J)	-40°C to +125°C

Thermal Resistance
 $\theta_{JA} \quad \theta_{JC}$

QFN-26 (5mmx5mm)

JESD51-7 (7) 44 9 °C/W

50mmx50mm 4-Layer PCB (8) .. 20 2 °C/W

NOTES:

- 1) Absolute maximum ratings are rated under room temperature unless otherwise noted. Exceeding these ratings may damage the device.
- 2) For details on EN's ABS max rating, please refer to the EN Control section on page 11.
- 3) The maximum allowable power dissipation is a function of the maximum junction temperature T_J (MAX), the junction-to-ambient thermal resistance θ_{JA} , and the ambient temperature T_A . The maximum allowable continuous power dissipation at any ambient temperature is calculated by P_D (MAX) = $(T_J$ (MAX) - T_A) / θ_{JA} . Exceeding the maximum allowable power dissipation produces an excessive die temperature, causing the regulator to go into thermal shutdown. Internal thermal shutdown circuitry protects the device from permanent damage. Measured on a 4-layer PCB (50mmx50mm).
- 4) HBM, per JEDEC specification JESD22-A114; CDM, per JEDEC specification JESD22-C101, AEC specification AEC-Q100-011. JEDEC document JEP155 states that 500V HBM allows safe manufacturing with a standard ESD control process. JEDEC document JEP157 states that 250V CDM allows safe manufacturing with a standard ESD control process.
- 5) HBM, with regard to GND.
- 6) The device is not guaranteed to function outside of its operating conditions.
- 7) The value of θ_{JA} given in this table is only valid for comparison with other packages and cannot be used for design purposes. These values were calculated in accordance with JESD51-7 and simulated on a specified JEDEC board. They do not represent the performance obtained in an actual application.
- 8) Measured on a four-layer PCB board, 50mmx50mm.

ELECTRICAL CHARACTERISTICS

$V_{IN} = 12V$, $V_{EN} = 5V$, CC1 to ground with a 5.1k Ω resistor, CC3 to ground with a 5.1k Ω resistor, $T_J = -40^{\circ}C$ to $+125^{\circ}C$, typical value is tested at $T_J = +25^{\circ}C$, unless otherwise noted.

Parameter	Symbol	Condition	Min	Typ	Max	Units
Supply current (shutdown)	I_{IN}	$V_{EN} = 0V$		13	18	μA
Supply current (quiescent)	I_{Q1}	No switching		1	2	mA
	I_{Q2}	CC floating, V_{BUS} disabled, $T_J = +25^{\circ}C$		200	300	μA
EN rising threshold	V_{EN_Rising}		-3%	1.235	+3%	V
EN hysteresis	V_{EN_HYS}			200		mV
EN pull-up current	I_{EN}		4	8	12	μA
Thermal shutdown ⁽⁹⁾	T_{TSD}			165		$^{\circ}C$
Thermal hysteresis ⁽⁹⁾	T_{TSD_HYS}			20		$^{\circ}C$
VCC regulator	V_{CC}		4.2	4.5	4.85	V
VCC load regulation	V_{CC_LOG}	$I_{CC} = 50mA$		1	3	%
Step-Down Converter						
V_{IN} under-voltage lockout threshold rising	V_{IN_UVLO}		4.6	5.0	5.4	V
V_{IN} under-voltage lockout threshold hysteresis	V_{UVLO_HYS}			700		mV
HS switch on resistance	R_{DSON_HS}			18	35	m Ω
LS switch on resistance	R_{DSON_LS}			15	30	m Ω
Output voltage	V_{OUT}	OUT_SEL = low	-2%	5.10	+2%	V
		OUT_SEL = float, $T_J = +25^{\circ}C$	-1%	5.17	+1%	
		OUT_SEL = float, $T_J = -40^{\circ}C$ to $+125^{\circ}C$	-2%	5.17	+2%	
		OUT_SEL = high	-2%	5.30	+2%	
Output over-voltage protection (OVP)	V_{OVP_R}		5.45	5.85	6.25	V
Output OVP recovery	V_{OVP_F}		5.3	5.7	6.1	V
Output to ground resistance	R_{FB}	$EN = 0V$, $T_J = +25^{\circ}C$	120	175	230	k Ω
Low-side current limit	I_{LS_LIMIT}			-2		A
Switch leakage	SW_{LKG}	$V_{EN} = 0V$, $V_{SW} = 36V$, $T_J = +25^{\circ}C$			1	μA
		$V_{EN} = 0V$, $V_{SW} = 36V$, $T_J = -40^{\circ}C$ to $+125^{\circ}C$			5	
High-side current limit	I_{LIMIT}	$V_{OUT} = 0V$	9	13	17	A
Oscillator frequency	F_{SW1}	Pull R_{FREQ} to GND	170	250	300	kHz
	F_{SW2}	$R_{FREQ} = 66.5k\Omega$	250	350	450	
	F_{SW3}	$R_{FREQ} = 9.53k\Omega$	1800	2200	2600	
	F_{SW4}	$R_{FREQ} = \text{float}$	350	450	530	
Frequency spread spectrum span	F_{ss1}	MPQ4488TGU-FD-AEC1, $R_{FREQ} = \text{float}$, based on 450kHz		± 10		%
	F_{ss2}	MPQ4488TGU-FD2-AEC1, $R_{FREQ} = \text{float}$, based on 250kHz				
Maximum duty cycle	D_{MAX}	$FREQ = 450kHz$	91	95	99	%

ELECTRICAL CHARACTERISTICS (continued)

$V_{IN} = 12V$, $V_{EN} = 5V$, CC1 to ground with a 5.1k Ω resistor, CC3 to ground with a 5.1k Ω resistor, $T_J = -40^{\circ}C$ to $+125^{\circ}C$, typical value is tested at $T_J = +25^{\circ}C$, unless otherwise noted.

Parameter	Symbol	Condition	Min	Typ	Max	Units
Minimum off time	T_{OFF_MIN}			110		ns
Minimum on time ⁽⁹⁾	T_{ON_MIN}			130		ns
Soft-start time	T_{SS}	Output from 10% to 90%	1	2	3.4	ms
USB Switch (USB1 and USB2)						
Under-voltage lockout threshold rising	V_{USB_UVR}		3.7	4	4.3	V
Under-voltage lockout threshold hysteresis	V_{USB_UVHYS}			200		mV
Switch on resistance	R_{DSON_SW}			13	30	m Ω
Output discharge resistance	R_{DIS_USB}	Apply 5V voltage to USB output, float CC	250	500	750	k Ω
USB OVP clamp	V_{USB_OV}		5.3	5.6	5.9	V
Current limit	I_{Limit1}	V_{OUT} drops 10%, Type-C mode, $T_J = +25^{\circ}C$	-6%	3.45	6%	A
	I_{Limit2}	V_{OUT} drops 10%, Type-A mode, $T_J = +25^{\circ}C$	2.6	2.75	2.9	
Line drop compensation	V_{DROP_COM}	At 2.4A load, $V_{OUT} = 5.17V$	40	90	140	mV
V_{BUS} soft-start time	T_{SS}	Output from 10% to 90%	1	2	3	ms
Hiccup mode on time	T_{HICP_ON2}	OC, V_{OUT} drops 10%, $T_J = +25^{\circ}C$	3.5	5	6.5	ms
		OC, V_{OUT} drops 10%, $T_J = -40^{\circ}C$ to $+125^{\circ}C$	3	5	7	
Hiccup mode off time	T_{HICP_OFF}	V_{OUT} connected to GND	1	2	3	s
BC1.2 DCP Mode						
DP and DM short resistance	R_{DP/DM_Short}	$V_{DP} = 0.8V$, $I_{DM} = 1mA$, $T_J = +25^{\circ}C$		85	155	Ω
		$V_{DP} = 0.8V$, $I_{DM} = 1mA$, $T_J = -40^{\circ}C$ to $+125^{\circ}C$		85	160	
Divider Mode						
DP/DM output voltage	$V_{DP/DM_Divider}$		2.55	2.7	2.85	V
DP/DM output impedance	$R_{DP/DM_Divider}$	$T_J = +25^{\circ}C$	14	22	30	k Ω
		$T_J = -40^{\circ}C$ to $+125^{\circ}C$	12	22	34	
1.2V/1.2V Mode						
DP/DM output voltage	$V_{DP/DM_1.2V}$	$V_{OUT} = 5V$, $T_J = +25^{\circ}C$	1.12	1.2	1.28	V
		$V_{OUT} = 5V$, $T_J = -40^{\circ}C$ to $+125^{\circ}C$	1.1	1.2	1.3	
DP/DM output impedance	$R_{DP/DM_1.2V}$	$T_J = +25^{\circ}C$	70	105	140	k Ω
		$T_J = -40^{\circ}C$ to $+125^{\circ}C$	60	105	150	

ELECTRICAL CHARACTERISTICS (continued)

$V_{IN} = 12V$, $V_{EN} = 5V$, CC1 to ground with a 5.1kΩ resistor, CC3 to ground with a 5.1kΩ resistor, $T_J = -40^{\circ}C$ to $+125^{\circ}C$, typical value is tested at $T_J = +25^{\circ}C$, unless otherwise noted.

Parameter	Symbol	Condition	Min	Typ	Max	Units
USB Type-C 5V @ 3A Mode – CC1, CC2, CC3, and CC4						
CC resistor to disable Type-C mode	R_A	CC1 and CC3. For Type-C mode applications, add a 1nF capacitor on CC1 and CC3	70		90	kΩ
CC voltage to enable V_{CONN}	V_{Ra}				0.75	V
CC voltage to enable V_{BUS}	V_{Rd}		0.9		2.45	V
CC detach threshold	V_{OPEN}		2.75			V
CC voltage falling debounce timer	$T_{CC_debounce}$	V_{BUS} enable deglitch	100	144	200	ms
CC voltage rising debounce timer	$T_{PD_debounce}$	V_{BUS} disable deglitch	10	15	20	ms
V_{CONN} output power	P_{VCONN}	V_{CONN} comes from the buck output with some series resistance, $T_J = +25^{\circ}C$	1			W

NOTES:

9) Guaranteed by engineering sample characterization.

TYPICAL PERFORMANCE CHARACTERISTICS

$V_{IN} = 12V$, $V_{OUT} = 5.17V$, $L = 4.7\mu H$, $T_A = 25^\circ C$, unless otherwise noted.

Output Ripple

$V_{IN}=12V$, $V_{OUT}=5.17V$,
USB1_I_{OUT}=USB2_I_{OUT}=0A

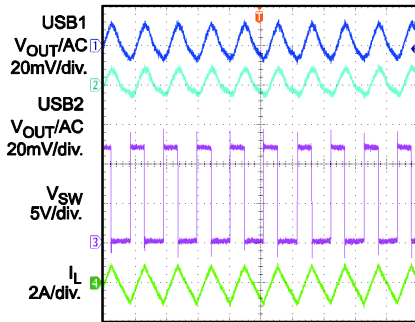

2 μ s/div.

Output Ripple

$V_{IN}=12V$, $V_{OUT}=5.17V$,
USB1_I_{OUT}=USB2_I_{OUT}=3A

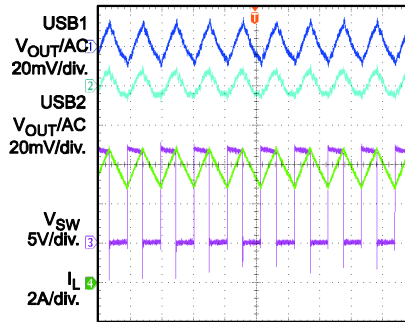

2 μ s/div.

Power Start-Up

$V_{IN}=12V$, $V_{OUT}=5.17V$,
USB1_I_{OUT}=USB2_I_{OUT}=0A

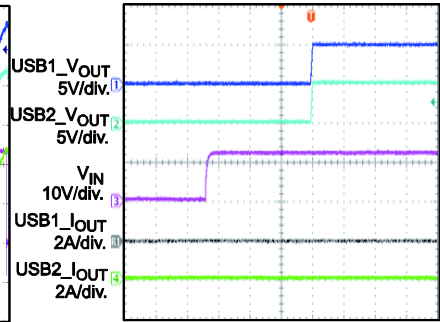

40ms/div

Power Start-Up

$V_{IN}=12V$, $V_{OUT}=5.17V$,
USB1_I_{OUT}=USB2_I_{OUT}=3A

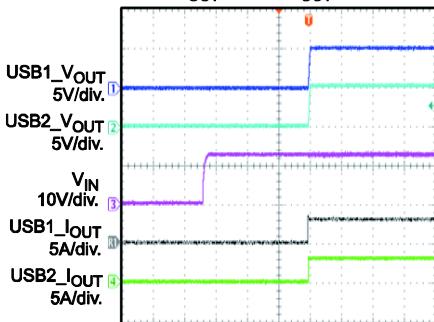

40ms/div

Power Shutdown

$V_{IN}=12V$, $V_{OUT}=5.17V$,
USB1_I_{OUT}=USB2_I_{OUT}=0A

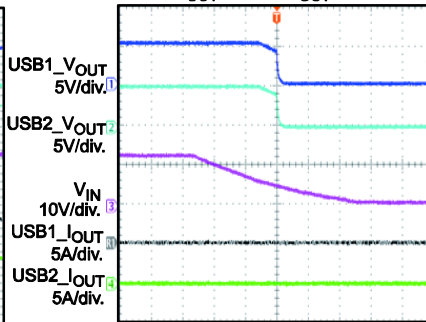

20ms/div

Power Shutdown

$V_{IN}=12V$, $V_{OUT}=5.17V$,
USB1_I_{OUT}=USB2_I_{OUT}=3A

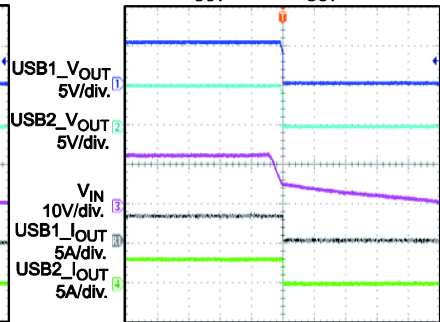

10ms/div

USB Over-Current Protection

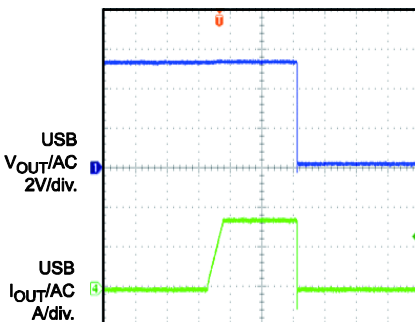

2ms/div

Load Shedding Entry

$V_{IN}=12V$, $V_{OUT}=5.17V$

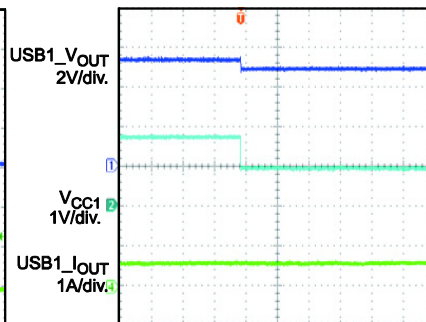

10ms/div

Load Shedding Recovery

$V_{IN}=12V$, $V_{OUT}=5.17V$

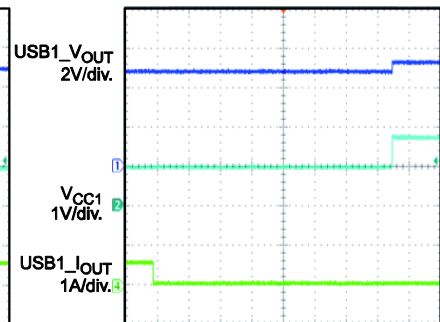

2s/div

TYPICAL PERFORMANCE CHARACTERISTICS (continued)

$V_{IN} = 12V$, $V_{OUT} = 5.17V$, $L = 4.7\mu H$, $T_A = 25^\circ C$, unless otherwise noted.

Efficiency vs. Load Current

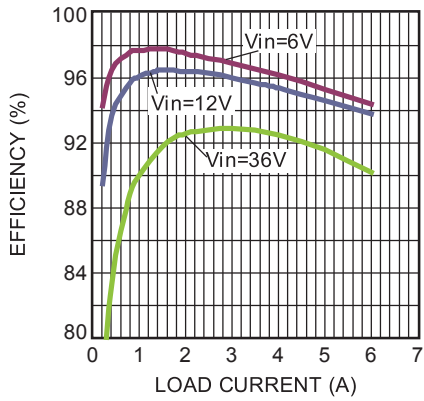

Line Drop Compensation vs. Load Current

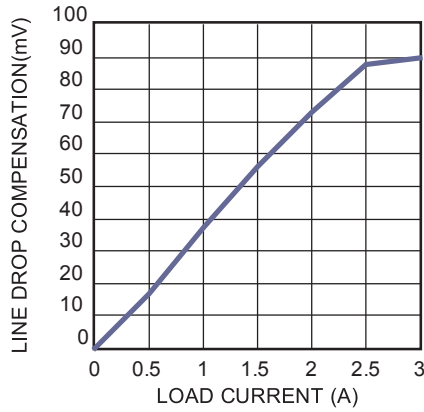

Thermal Image

$V_{IN}=12V$,
 $USB1_I_{OUT}=USB2_I_{OUT}=2.4A$
 4 layer PCB, 50mm x 50mm

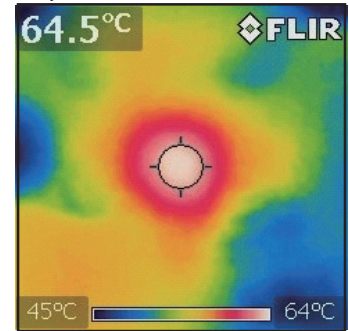

Thermal Image

$V_{IN}=12V$,
 $USB1_I_{OUT}=2.4A$, $USB2_I_{OUT}=3A$
 4 layer PCB, 50mm x 50mm

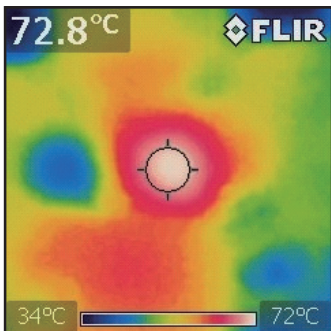

Thermal Image

$V_{IN}=12V$,
 $USB1_I_{OUT}=3A$, $USB2_I_{OUT}=3A$
 4 layer PCB, 50mm x 50mm

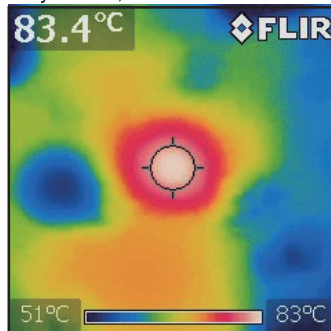

BLOCK DIAGRAM

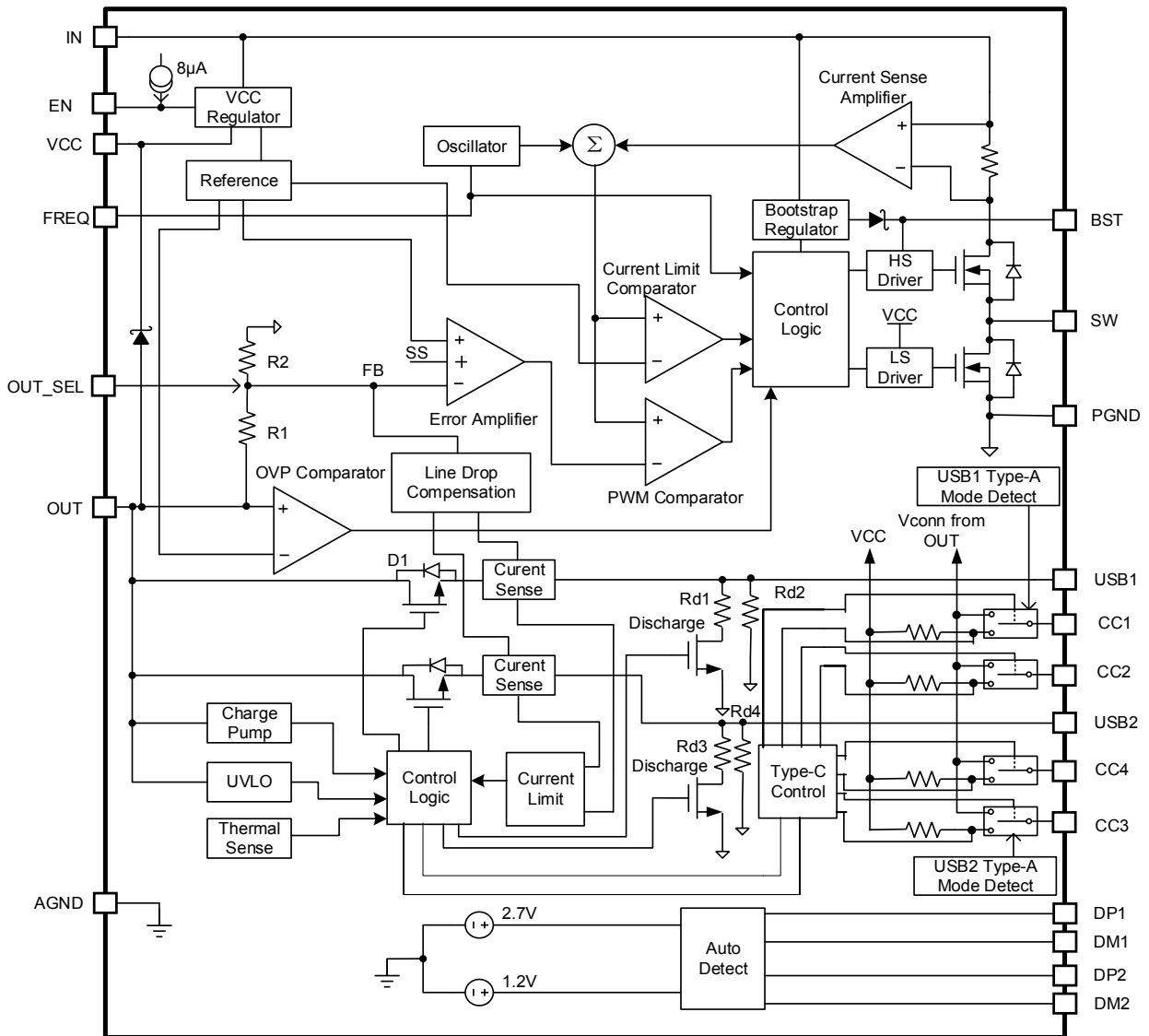

Figure 1: Functional Block Diagram

OPERATION

BUCK CONVERTER SECTION

The MPQ4488T integrates a monolithic, synchronous, rectified, step-down, switch-mode converter with internal power MOSFETs and two USB current-limit switches with charging port auto-detection. The MPQ4488T offers a compact solution that achieves 6A of continuous output current with excellent load and line regulation over a wide input supply range.

The MPQ4488T operates in a fixed-frequency, peak-current-mode control to regulate the output voltage. The internal clock initiates the pulse-width modulation (PWM) cycle, which turns on the integrated high-side power MOSFET (HS-FET). The HS-FET remains on until its current reaches the value set by the COMP voltage (V_{COMP}). When the power switch is off, it remains off until the next clock cycle begins. If the duty cycle reaches 95% (450kHz switching frequency) in one PWM period, the current in the power MOSFET cannot reach the COMP-set current value, and the power MOSFET turns off.

Error Amplifier (EA)

The error amplifier (EA) compares the internal feedback voltage against the internal reference (REF) and outputs a V_{COMP} value, which controls the power MOSFET current. The optimized, internal compensation network minimizes the external component count and simplifies the control loop design.

Internal VCC Regulator

The 4.5V internal regulator powers most of the internal circuitries. This regulator takes V_{IN} and operates in the full V_{IN} range. When V_{IN} exceeds 4.5V, the output of the regulator is in full regulation. If V_{IN} is less than 4.5V, the output decreases with V_{IN} . VCC requires an external 1 μ F ceramic decoupling capacitor.

After the buck output starts up, the internal VCC LDO output is biased by the buck output through a Schottky diode.

Enable Control (EN)

The MPQ4488T has an enable control pin (EN). An internal 8 μ A pull-up current allows EN to be floated for automatic start-up. Pull EN high or

float EN to enable the IC. Pull EN low to disable the IC.

EN is clamped internally using a 7.6V series Zener diode and 10V breakdown voltage of an ESD cell (see Figure 2).

Connect EN through divider resistors to V_{IN} and GND is recommended. When selecting pull-up resistor, ensure that it is large enough to limit the current flow into EN Pin is below 100 μ A.

For example, select EN pull up resistor is 100k Ω , pull down resistor is 32.4k Ω , then IC will power up when V_{in} is larger than UVLO rising threshold and will power off when $V_{IN} < V_{IN}$ UVLO falling threshold.

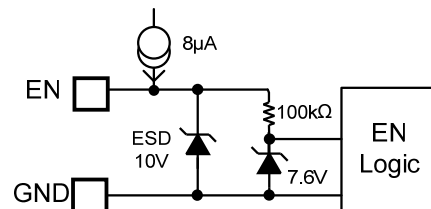

Figure 2: Zener Diode between EN and GND

Setting the Switching Frequency

Connect a resistor from FREQ to ground to set the switching frequency (see Table 1). The value of the frequency can be calculated approximately with Equation (1):

$$FREQ(kHz) = \frac{1000000}{42.5 \times R_{FREQ}(K\Omega) + 53.7} \quad (1)$$

The frequency vs. R_{FREQ} is shown in Figure 3.

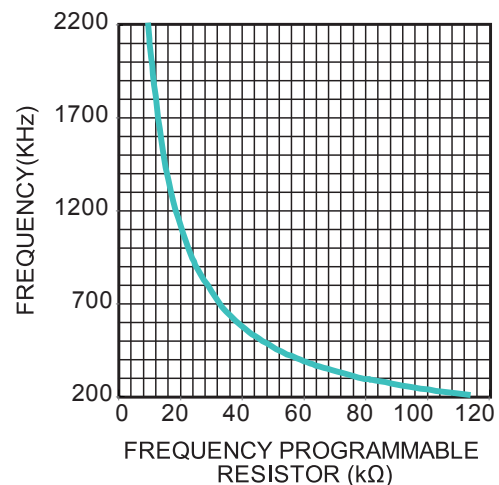

Figure 3: Switching Frequency vs. R_{FREQ}

Table 1: Recommended Resistor Values for Typical Switching Frequency

R _{FREQ} (kΩ)	F _s (kHz)
0	250
66.5	350
NS	450
45.8	500
22.3	1000
14.6	1500
9.53	2200

When running the part at a high switching frequency (i.e.: 2.2MHz), consider the minimum on time, minimum off time, and the maximum output current due to the thermal rise.

Two internal comparators monitor FREQ's logic voltage to enable FREQ to be floated or shorted to GND. During power-up, there is another internal source current on FREQ. The frequency is locked at 450kHz when a voltage greater than 2V is sensed on FREQ for longer than 8μs. The frequency is locked at 250kHz when a voltage lower than 0.1V is sensed on FREQ for longer than 8μs. Leave FREQ floating or connect FREQ to VCC to achieve the 450kHz default switching frequency. Short FREQ to ground to achieve a 250kHz frequency (see Figure 4).

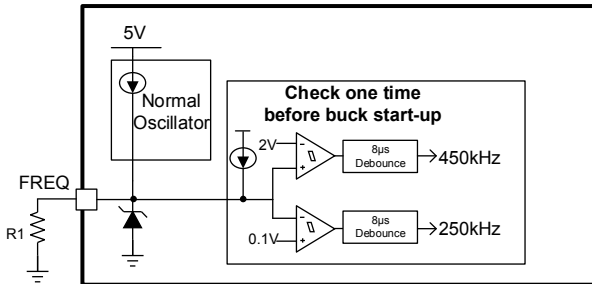
Figure 4: Switching Frequency Functional Block

Frequency Spread Spectrum
The purpose of spread spectrum is to minimize the peak emissions at some specific frequency.

MPQ4488TGU-FD-AEC1/MPQ4488TGU-FD2-AEC1 uses a 4kHz triangle wave (rising 125μs, falling 125μs) to modulate internal oscillator. The frequency span of spread spectrum operation is ±10%. Refer to Figure 5.

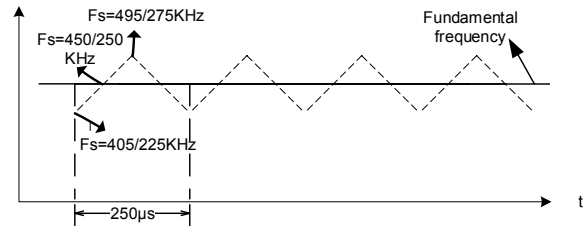
Figure 5, Frequency Spread Spectrum

FREQ pin must be floated or connected to VCC when using spread spectrum function. Part will work without switching frequency spread spectrum when FREQ pin is connected to external resistor or short to GND.

Pull FREQ to GND can set fixed switching frequency at 250kHz without frequency spread spectrum; frequency is determined by external resistor when connect FREQ to GND through resistor.

Under-Voltage Lockout (UVLO)

Under-voltage lockout (UVLO) protects the chip from operating at an insufficient supply voltage. The UVLO comparator monitors the input voltage. The UVLO rising threshold is 5V, and its falling threshold is 4.3V.

Internal Soft Start (SS)

Soft start (SS) prevents the converter output voltage from overshooting during start-up. When the chip starts up, the internal circuitry generates a SS voltage that ramps up from 0 - 5V. When SS is lower than REF, the error amplifier uses SS as the reference. When SS is higher than REF, the error amplifier uses REF as the reference. The SS time is set to 2ms internally. If the output of the MPQ4488T is pre-biased to a certain voltage during start-up, the IC disables the switching of both the high-side and low-side switches until the voltage on the internal SS capacitor exceeds the internal feedback voltage.

Forced CCM Operation

The MPQ4488T works in forced continuous conduction mode (CCM) continuously. The MPQ4488T operates with a fixed switching frequency regardless of whether it is operating in light load or full load. The advantage of CCM is the controllable frequency, smaller output ripple, and sufficient bootstrap charge time, but it also has low efficiency at light-load condition.

A proper inductance should be selected to avoid triggering the low-side switch's negative current limit (typically 2A, from SW to GND). If the negative current limit is triggered, the low-side switch turns off, and the high-side switch turns on when internal clock begins.

Buck Over-Current Protection (OCP)

The MPQ4488T has a cycle-by-cycle over-current limit when the inductor peak current exceeds the current-limit threshold, and the FB voltage drops below the under-voltage (UV) threshold (typically 50% below the reference). Once UV is triggered, the MPQ4488T enters hiccup mode to restart the part periodically. This protection mode is especially useful when the output is dead-shortened to ground. This reduces the average short-circuit current greatly, alleviates thermal issues, and protects the regulator. The MPQ4488T exits hiccup mode once the over-current condition is removed.

Buck Output Over-Voltage Protection (OVP)

The MPQ4488T has output over-voltage protection (OVP). If the output is higher than 5.85V, the high-side switch stops turning on. The low-side switch turns on to discharge the output voltage until the output decreases to 5.7V, and then the chip resumes normal operation.

Floating Driver and Bootstrap Charging

An external bootstrap capacitor powers the floating power MOSFET driver. This floating driver has its own UVLO protection. The UVLO's rising threshold is 2.2V with a hysteresis of 150mV. The bootstrap capacitor voltage is regulated internally by V_{IN} and VCC through D1, D2, M1, C4, L1, and C2 (see Figure 6). The BST capacitor (C4) voltage is charged quickly by turning on M1 when the low-side switch is turned on. The 2.5 μ A input to the BST current source can also charge the BST capacitor when the low-side switch is not on.

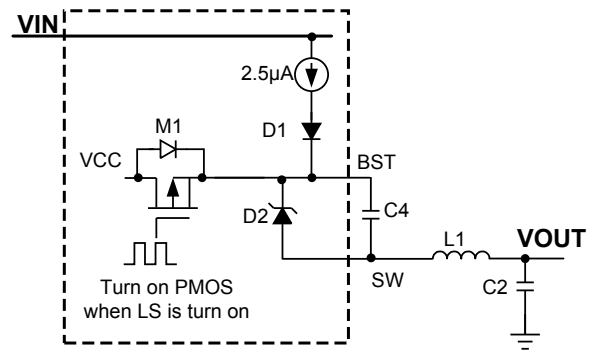

Figure 6: Internal Bootstrap Charging Circuit

Start-Up and Shutdown

If both IN and EN exceed their respective thresholds, the chip is enabled. The reference block starts first, generating a stable reference voltage and current, and then the internal regulator is enabled. The regulator provides a stable supply for the remaining circuitries.

Three events can shut down the chip: EN low, IN low, and thermal shutdown. During shutdown, the signaling path is blocked to avoid any fault triggering. Then V_{COMP} and the internal supply rail are pulled down. The floating driver is not subject to this shutdown command.

Buck Output Impedance

The buck does not involve an output discharge function during EN shutdown. After EN shuts down, there are only two feedback resistors connected to OUT, which have a typical resistance of 175k Ω total.

USB CURRENT-LIMIT SWITCH SECTION

Over-Current Protection (OCP) and Hiccup

The MPQ4488T integrates two USB current-limit switches. The MPQ4488T provides built-in, soft-start circuitry, which controls the rising slew rate of the output voltage to limit inrush current and voltage surges.

When the load current reaches the current-limit threshold, the USB power MOSFET works in a constant current-limit mode (see Figure 7). If the over-current limit condition lasts longer than 5ms (V_{OUT} does not drop too low), the corresponding USB channel enters hiccup mode with 5ms of on time and 2s of off time. Another USB channel works normally.

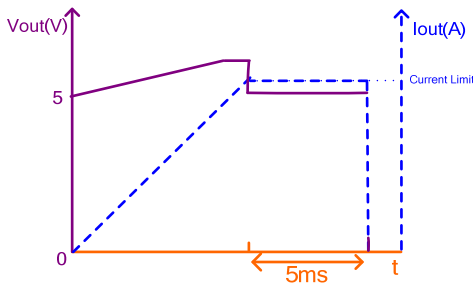
Figure 7: Over-Current Limit

After the soft start finishes, if the USB output voltage is lower than 3.5V and lasts longer than 50 μ s, the MPQ4488T enters hiccup mode without having to wait 5ms (see Figure 8). This can prevent an abnormal thermal rise during the constant resistor (CR) load over-current case.

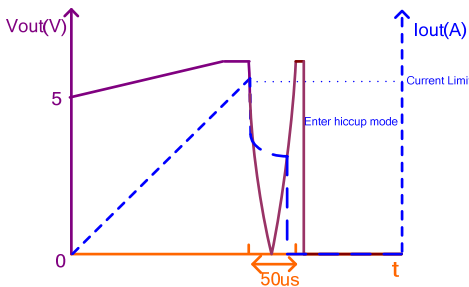
Figure 8: Over-Current Limit for CR Load

Fast Response for Short-Circuit Protection (SCP)

If the load current increases rapidly due to a short-circuit event, the current may exceed the current-limit threshold before the control loop is able to respond. If the current reaches the 7A secondary current-limit level, a fast turn-off circuit activates to turn off the power MOSFET. This can help limit the peak current through the switch, keeping the buck output voltage from dropping too much and affecting another USB channel. The total short-circuit response time is less than 1 μ s.

When the fast turn-off function is triggered, the MOSFET turns off for 100 μ s and restarts with a soft start. During the restart process, if the short still remains, the MPQ4488T regulates the gate voltage to hold the current at a normal current limit level.

Output Line Drop Compensation

The MPQ4488T can compensate for an output voltage drop, such as high impedance caused by a long trace, to maintain a fairly constant output voltage at the load-side voltage.

The internal comparator compares the current-sense output voltage of the two current-limit switches and uses the larger current-sense output voltage to compensate for the line drop voltage.

The line drop compensation amplitude increases linearly as the load current increases and also has an upper limitation. The line drop compensation at a >2.4A output current is 90mV.

USB Output Over-Voltage Clamp

To protect the device at the cable terminal, the USB switch output has a fixed over-voltage protection (OVP) threshold. When the input voltage is higher than the OVP threshold, the output voltage is clamped to its OVP threshold value.

USB Output Discharge and Impedance

Each USB switch has a fast discharge path that can discharge the external output capacitor's energy quickly during a power shutdown. This function is active when the CC pins are released or the part is disabled (input voltage is under UVLO or EN off). The discharge path is turned off when the USB output voltage is discharged below 50mV. After the fast discharge path turns off, there is only a high impedance resistor (typically 500k Ω) from USB1 or USB2 to ground.

Auto-Detection

The MPQ4488T integrates a USB-dedicated charging port auto-detect function. This function recognizes most mainstream portable devices and supports the following charging schemes:

- USB battery charging specification BC1.2/ Chinese Telecommunications Industry Standard YD/T 1591-2009
- Apple divider mode
- 1.2V/1.2V mode
- USB Type-C 5V @ 3A DFP mode

The auto-detect function is a state machine that

supports all of the DCP charging schemes above.

USB Type-C Mode and VCONN

For USB Type-C solutions, two pins on the connector (CC1, CC2) are used to establish and manage the source-to-sink connection. The general concept for setting up a valid connection between a source and a sink is based on being able to detect terminations residing in the product being attached. To aid in defining the functional behavior of CC, a pull-up (R_p) and pull-down (R_d 5.1k Ω) termination model is used based on a pull-up resistor and pull-down resistor (see Figure 9).

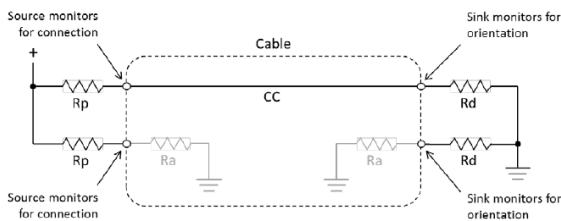

Figure 9: Current Source/Pull-Down CC Model

Initially, a source exposes independent R_p terminations on its CC1 and CC2 pins, and a sink exposes independent R_d terminations on its CC1 and CC2 pins. The source-to-sink combination of this circuit configuration represents a valid connection. To detect this, the source monitors CC1 and CC2 for a voltage lower than its unterminated voltage. The choice of R_p is a function of the pull-up termination voltage and the source's detection circuit. This indicates that either a sink, a powered cable, or a sink connected via a powered cable has been attached.

Prior to the application of VCONN, a powered cable exposes R_a (typically 1k Ω) on its VCONN pin. R_a represents the load on VCONN plus any resistive elements to ground. In some cable plugs, this might be a pure resistance, and in others, it may simply be the load.

The source must be able to differentiate between the presence of R_d and R_a to know whether there is a sink attached and where to apply VCONN. The source is not required to source VCONN unless R_a is detected.

Two special termination combinations on the CC pins as seen by a source are defined for

directly attached accessory modes: R_a/R_a for audio adapter accessory mode and R_d/R_d for debug accessory mode (see Figure 10 and Table 2).

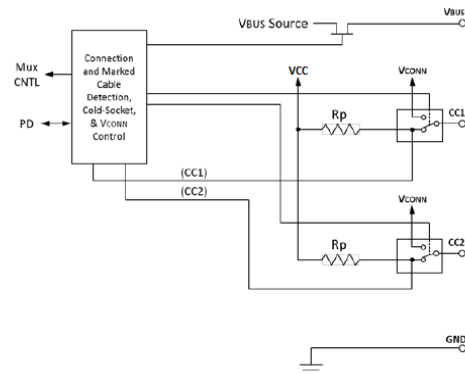

Figure 10: CC Functional Block

A port that behaves as a source has the following functional characteristics.

1. The source uses a MOSFET to enable or disable the power delivery across V_{BUS} . Initially, the source is disabled.
2. The source supplies pull-up resistors (R_p) on CC1 and CC2 and monitors both to detect a sink. The presence of an R_d pull-down resistor on either CC1 or CC2 indicates that a sink is being attached. The value of R_p indicates the initial USB Type-C current level supported by the host. The MPQ4488T default R_p value is 10k Ω , which represents a 3A current level.
3. The source uses the CC pull-down characteristic to detect and determine which CC pin is intended to supply VCONN (when R_a is discovered).
4. Once a sink is detected, the source enables V_{BUS} and VCONN.
5. The source can adjust the value of R_p dynamically to indicate a change in the available USB Type-C current to a sink. For example, at high temperatures, the MPQ4488T changes R_p to 22k Ω to indicate a 1.5A current ability.
6. The source monitors the continued presence of R_d to detect a sink detach. When a detach event is detected, the source is removed, and V_{BUS} and VCONN return to step 2.

Disable Type-C Mode (Type-A Mode)

During the MPQ4488T’s initial start-up, the IC sources 10µA for 20µs on CC1. If the CC1 voltage falls into a 400mV to 1.2V voltage range, USB1 latches in Type-A mode unless the part is re-enabled. Type-C mode is disabled, so CC is attached, the detach logic is disabled, and V_{BUS} is always enabled. The current limit changes to a Type-A spec. The same logic is implemented on CC3 for USB2.

To trigger Type-A mode, the external pull-down resistor should be 70 - 90kΩ. Do not connect extra capacitors on CC1 and CC3. In normal Type-C mode applications, a 1nF capacitor should be added on CC1 and CC3 to avoid triggering Type-A mode falsely.

The MPQ4488T also supports debug mode and audio adapter accessory mode in Type-C applications. If two Ra resistors pull down CC1 and CC2, or two Rd resistors pull down CC1 and CC2, then there is no action inside the IC (V_{BUS} is not enabled).

Load Shedding vs. Temperature

The MPQ4488T monitors the die temperature and changes its output current capability dynamically. This feature is supported by both Type-C and USB2.0 applications.

When the die temperature is higher than 135°C, the USB port’s CC pin pull-up resistance (Rp) changes to 22kΩ to indicate that its source capability has changed to 1.5A. Meanwhile, V_{BUS} changes to 4.77V.

If the die temperature is lower than 110°C for 16 seconds, V_{BUS} reverts to the normal voltage set by OUT_SEL. Meanwhile, the USB Type-C current capability changes back to 3A (Rp = 10kΩ). The current limit threshold remains at 3.45A during this period.

Thermal Shutdown

Thermal shutdown prevents the chip from operating at exceedingly high temperatures. When the silicon die temperature exceeds 165°C, the entire chip shuts down. When the temperature falls below its lower threshold (typically 145°C), the chip is enabled.

Table 2: CC Logic Truth Table

EN	CC of USB1 (10)	CC of USB2 (10)	Buck	V _{CONN} (USB1)	USB1	V _{CONN} (USB2)	USB2
0	X	X	Disabled	Disabled	Disabled	Disabled	Disabled
1	AUDIO	Open or AUDIO or DEBUG	Disabled	Disabled	Disabled	Disabled	Disabled
	DEBUG		Disabled	Disabled	Disabled	Disabled	Disabled
	“A” (11)		Enabled	Disabled	Enabled	Disabled	Disabled
	Rd, Ra		Enabled	Enabled	Enabled	Disabled	Disabled
	Open		Disabled	Disabled	Disabled	Disabled	Disabled
1	AUDIO	Rd, Ra	Enabled	Disabled	Disabled	Enabled	Enabled
	DEBUG		Enabled	Disabled	Disabled	Enabled	Enabled
	“A”		Enabled	Disabled	Enabled	Enabled	Enabled
	Rd, Ra		Enabled	Enabled	Enabled	Enabled	Enabled
	Open		Enabled	Disabled	Disabled	Enabled	Enabled
1	AUDIO	“A”	Enabled	Disabled	Disabled	Disabled	Enabled
	DEBUG		Enabled	Disabled	Disabled	Disabled	Enabled
	“A”		Enabled	Disabled	Enabled	Disabled	Enabled
	Rd, Ra		Enabled	Enabled	Enabled	Disabled	Enabled
	Open		Enabled	Disabled	Disabled	Disabled	Enabled

NOTES:

10) USB1 and USB2 are symmetric to each other.

11) "A" refers to Type-A mode. CC1 (CC3 for USB2) should be pulled down by an 80.6kΩ resistor to enter this mode.

APPLICATION INFORMATION

Selecting the Inductor

For most applications, use an inductor with a DC current rating at least 25% higher than the maximum load current. Select an inductor with a small DC resistance for optimum efficiency. For most designs, the inductor value can be derived with Equation (2):

$$L_1 = \frac{V_{OUT} \times (V_{IN} - V_{OUT})}{V_{IN} \times \Delta I_L \times f_{OSC}} \quad (2)$$

Where ΔI_L is the inductor ripple current.

Choose the inductor ripple current to be approximately 30%~50% of the maximum load current. The maximum inductor peak current can be calculated with Equation (3):

$$I_{L(MAX)} = I_{LOAD} + \frac{\Delta I_L}{2} \quad (3)$$

Selecting the Buck Input Capacitor

The input current to the step-down converter is discontinuous and therefore requires a capacitor to supply AC current while maintaining the DC input voltage. For the best performance, use low ESR capacitors for optimum performance. Ceramic capacitors with X5R or X7R dielectrics are highly recommended because of their low ESR and small temperature coefficients. 100 μ F electrolytic and 50 μ F ceramic capacitors are recommended in automotive applications at a 450kHz switching frequency.

Since the input capacitor (C1) absorbs the input switching current, it requires an adequate ripple current rating. The RMS current in the input capacitor can be estimated with Equation (4):

$$I_{C1} = I_{LOAD} \times \sqrt{\frac{V_{OUT}}{V_{IN}} \times \left(1 - \frac{V_{OUT}}{V_{IN}}\right)} \quad (4)$$

The worst-case condition occurs at $V_{IN} = 2V_{OUT}$, shown in Equation (5):

$$I_{C1} = \frac{I_{LOAD}}{2} \quad (5)$$

For simplification, choose an input capacitor with an RMS current rating greater than half of the maximum load current.

The input capacitor can be electrolytic, tantalum, or ceramic. When using an electrolytic capacitor, place two additional high-quality ceramic capacitors as close to IN as possible. Estimate the input voltage ripple caused by the capacitance with Equation (6):

$$\Delta V_{IN} = \frac{I_{LOAD}}{f_s \times C1} \times \frac{V_{OUT}}{V_{IN}} \times \left(1 - \frac{V_{OUT}}{V_{IN}}\right) \quad (6)$$

Selecting the Buck Output Capacitor

The device requires an output capacitor (C2) to maintain the DC output voltage. Estimate the output voltage ripple with Equation (7):

$$\Delta V_{OUT} = \frac{V_{OUT}}{f_s \times L_1} \times \left(1 - \frac{V_{OUT}}{V_{IN}}\right) \times \left(R_{ESR} + \frac{1}{8 \times f_s \times C2}\right) \quad (7)$$

Where L_1 is the inductor value, and R_{ESR} is the equivalent series resistance (ESR) value of the output capacitor.

For an electrolytic capacitor, the ESR dominates the impedance at the switching frequency. For simplification, the output ripple can be approximated with Equation (8):

$$\Delta V_{OUT} = \frac{V_{OUT}}{f_s \times L_1} \times \left(1 - \frac{V_{OUT}}{V_{IN}}\right) \times R_{ESR} \quad (8)$$

A 100 - 270 μ F capacitor with an ESR less than 50m Ω (e.g.: polymer or tantalum capacitors) and three 10 μ F ceramic capacitors are recommended in the application (see Table 3).

Table 3: Recommended External Components

Switching Frequency	Inductor	Input Cap	Buck Output Capacitor
250kHz	8 μ H	50 μ F ceramic cap + 100 μ F E-cap	30 μ F ceramic cap + 270 μ F Polymer cap
450kHz	4.7 μ H	50 μ F ceramic cap + 100 μ F E-cap	30 μ F ceramic cap + 270 μ F Polymer cap

ESD Protection for I/O Pins

Higher ESD levels should be considered for all USB I/O pins. The MPQ4488T features high ESD protection up to $\pm 8\text{kV}$ human body model on DP, DM, USB1, and USB2, and $\pm 5.5\text{kV}$ human body model on CC1 through CC4. The ESD structures can withstand high ESD both in normal operation and when the device is powered off. To further extend DP and DM's ESD level for covering complicated application environments, additional resistors and capacitors can be added (see Figure 11).

Similar R-C networks cannot be added on CC1 or CC2 because the CC line must be able to support 200mA of current and 300kHz of signaling. Additional ESD diodes can be added on the CC pins.

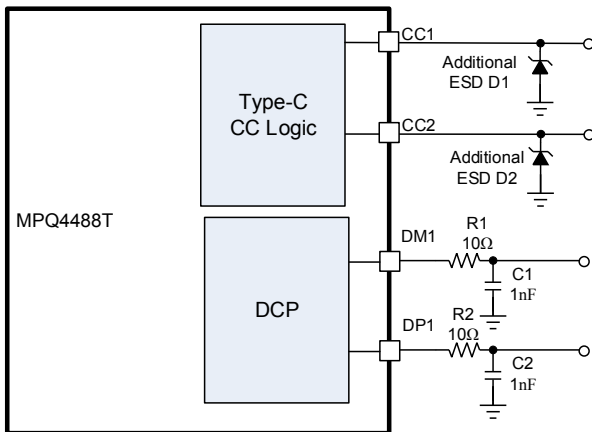

Figure 11: Recommended I/O Pins ESD Enhancing

PCB Layout Guidelines ⁽¹²⁾

Efficient PCB layout is critical for stable operation and thermal dissipation. For best results, refer to Figure 12 and follow the guidelines below.

1. Use short, direct, and wide traces to connect OUT.
2. Add vias under the IC.
3. Route the OUT trace on both PCB layers.
4. Place the buck output ceramic capacitor C2A and C2B on the left side and C2C on the right side.
5. Add a large copper plane for PGND.
6. Add multiple vias to improve thermal dissipation.
7. Connect AGND to PGND.
8. Place a large copper plane for SW, USB, and USB2.
9. Route the USB1 and USB2 traces on both PCB layers.
10. Add multiple vias.
11. Place two ceramic input decoupling capacitors as close to IN and PGND as possible to improve EMI performance.
12. Place the symmetric C_{IN} capacitors on each side of the IC.
13. Place the BST capacitor close to BST and SW.
14. Place the VCC decoupling capacitor as close to VCC as possible.

NOTE:

¹²⁾ The recommended layout is based on the Typical Application Circuits in Figure 13 through Figure 15.

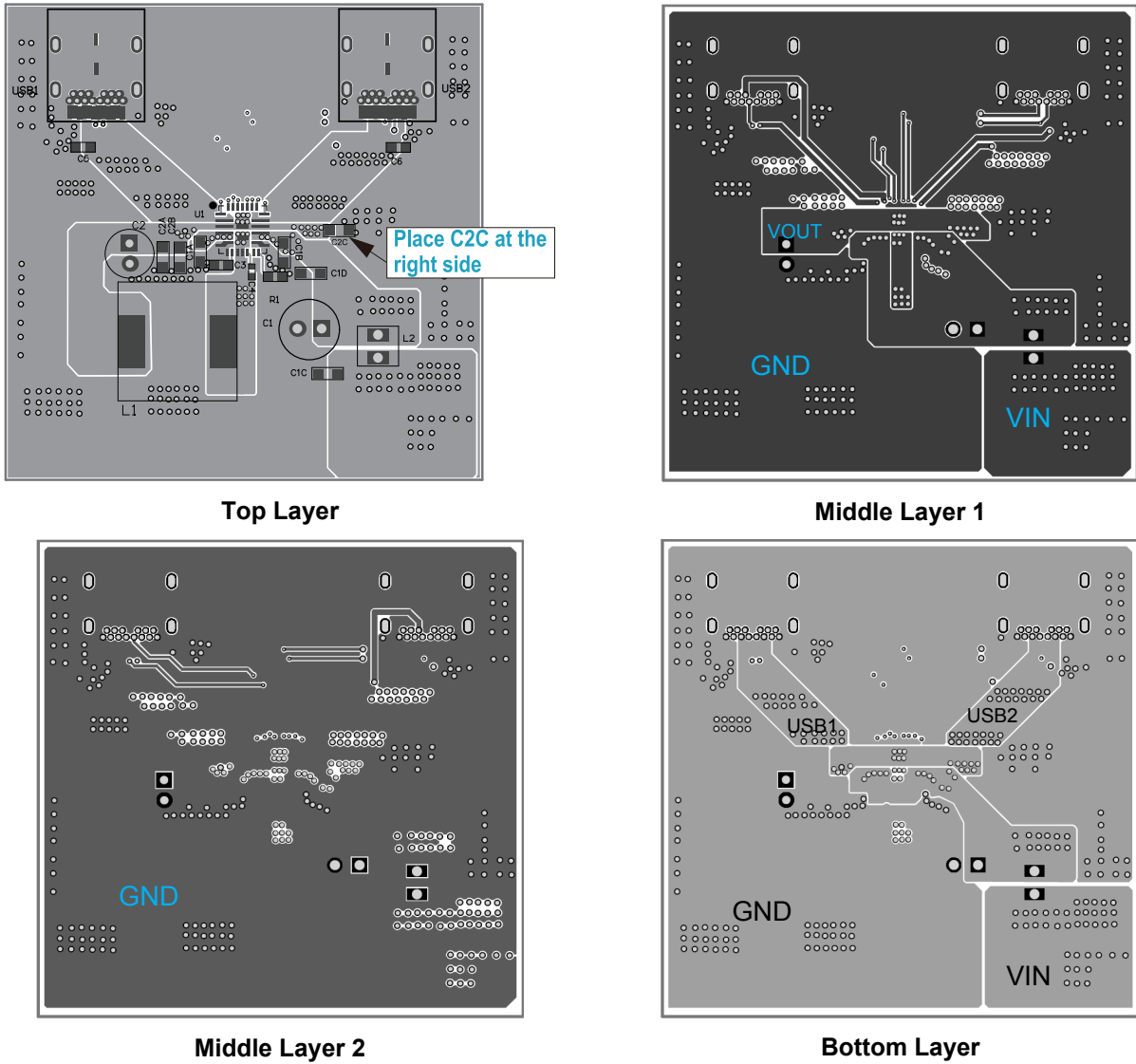

Figure 12: Recommended Layout

TYPICAL APPLICATION CIRCUITS

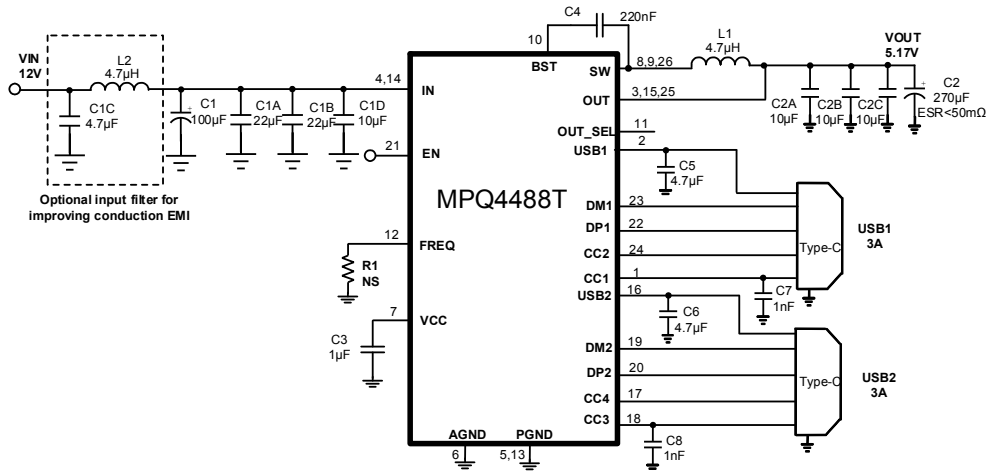

Figure 13: Dual USB Type-C 5V/3A DFP Ports (13)

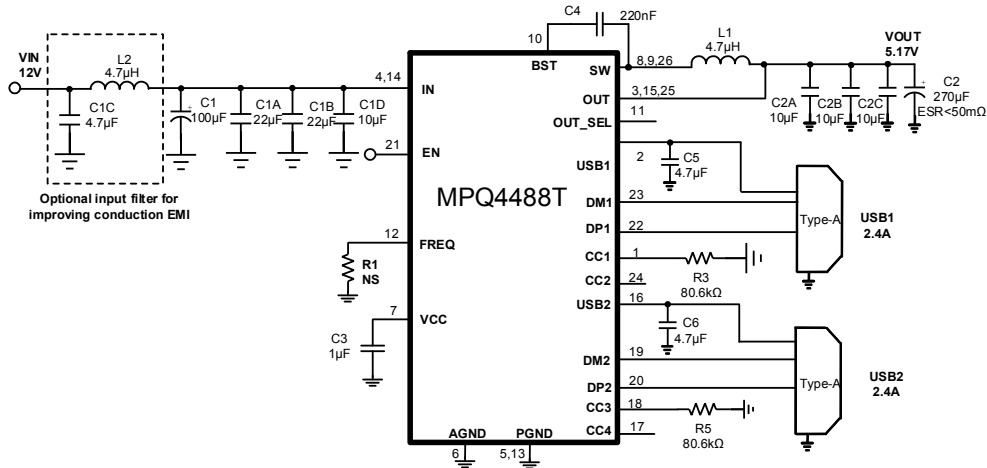

Figure 14: Dual USB Type-A 5V/2.4A Ports (13)

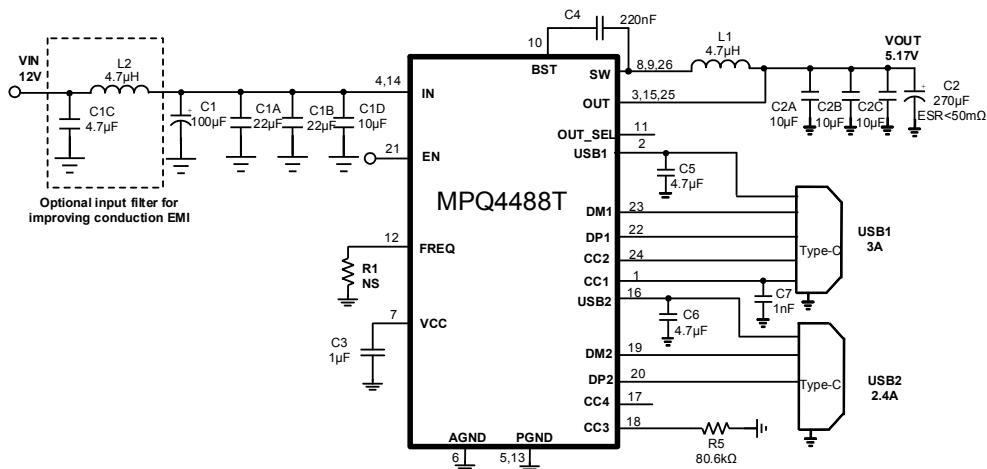

Figure 15: One Type-C 5V/3A DFP Port, One Type-A 5V/2.4A Port (13)

NOTE:

13) See Figure 11 for I/O pins' ESD protection enhancing details.

PACKAGE INFORMATION

QFN-26 (5mmx5mm)

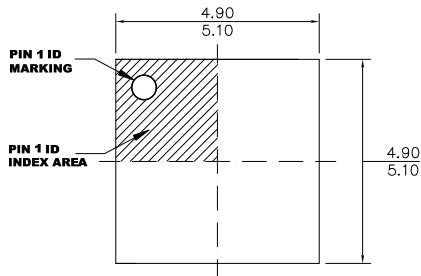

TOP VIEW

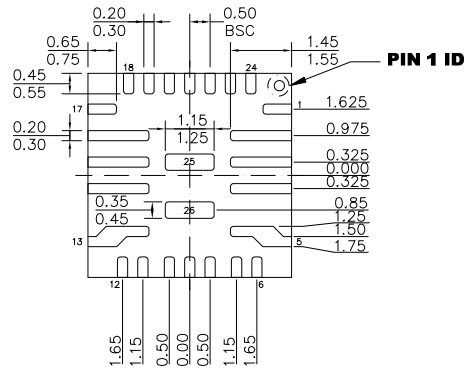

BOTTOM VIEW

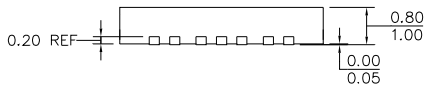

SIDE VIEW

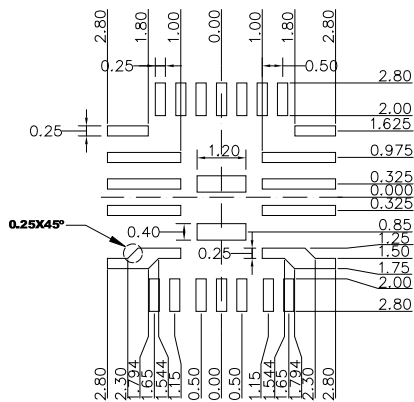

RECOMMENDED LAND PATTERN

NOTE:

- 1) LAND PATTERNS OF PIN 2~4 AND 14~16 HAVE THE SAME LENGTH AND WIDTH.
- 2) LAND PATTERNS OF PIN 5 AND PIN13 HAVE THE SAME LENGTH AND WIDTH.
- 3) ALL DIMENSIONS ARE IN MILLIMETERS.
- 4) LEAD COPLANARITY SHALL BE 0.10 MILLIMETERS MAX.
- 5) REFERENCE IS MO-220.
- 6) DRAWING IS NOT TO SCALE.