

**MR-BusIO-BUZZER™ BusIO BUZZER OUTPUT BOARD
User Manual**

GRAVITECH.US



uResearch

GRAVITECH GROUP

Copyright © 2007 MicroResearch
GRAVITECH GROUP WWW.GRAVITECH.US

MR-BusIO-BUZZER™ BusIO BUZZER OUTPUT BOARD User Manual

Description

The MR-BusIO-BUZZER is an Experiment board for buzzer output. The input signal is isolated from buzzer driver circuitry by PC817 Photo-coupler IC.

The board can be use with MR-BusIO-MAIN board or stand-alone. PCB size is 0.63" x 2.80"

Operation:

The PC817 require at least 5mA to drive input photo-coupler LED. It can take up to 6V in reverse bias. For an output (between collector and emitter), it can drive up to 35V with 50mA continuous current.

The operation of this board starts when applying logic HIGH to an I/O pin. The indicator LED then illuminated. The output of PC817 is driving second BC547 transistor which drive the output buzzer.

This board can be uses to make buzzer sound.



MR-BusIO-MAIN

The MR-BusIO-MAIN is available for purchase via our website. If you don't see the item you need, please contract our sales department at sales@gravitech.us

- **MR-BusIO-MAIN**

Experiment board which receives output signals from any microcontrollers. The signals then distribute to daughter boards for each experiment. It designed to connect directly with 10PIN MRconnect®. It is a quick and easy way to control up to 8 daughter boards.



MR-BusIO-BUZZER™ BusIO BUZZER OUTPUT BOARD User Manual

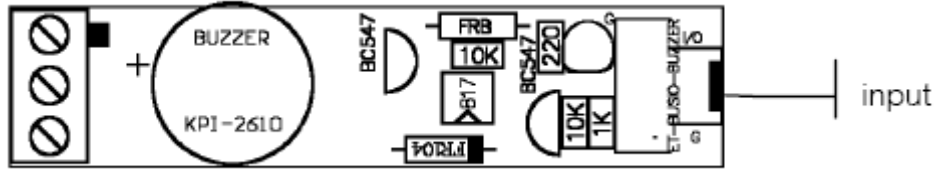

FIG 1: MR-BusIO-BUZZER Board Layout

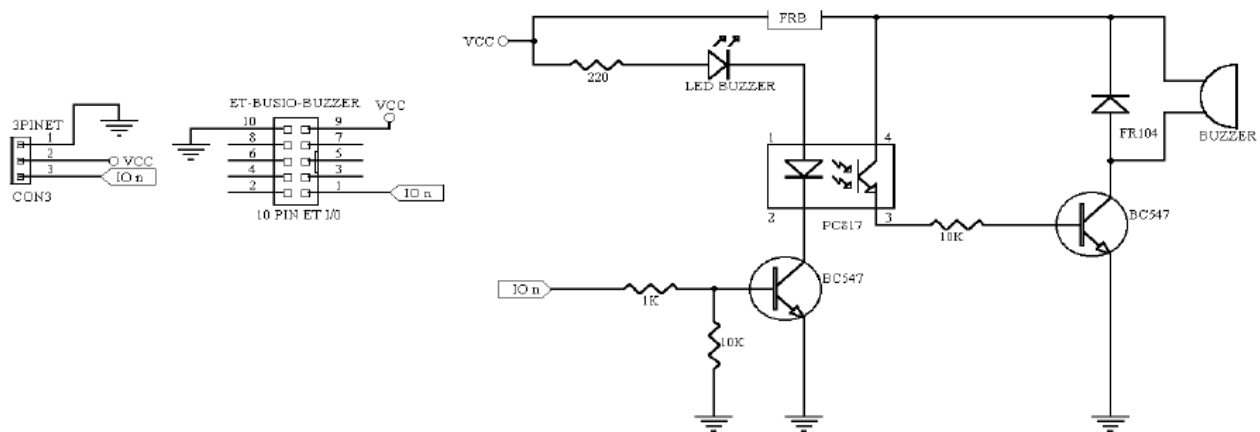

FIG 2: MR-BusIO-BUZZER Schematic