

**MR-BusIO-SSRAC™ BusIO Solid State Relay BOARD
User Manual**

GRAVITECH.US

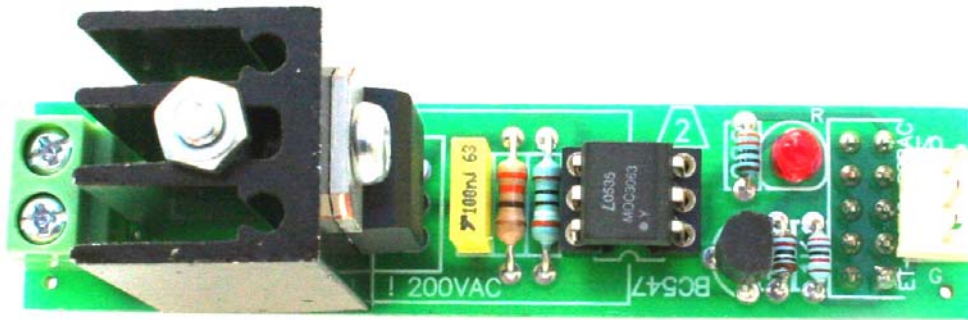

uResearch

GRAVITECH GROUP

Copyright © 2007 MicroResearch
GRAVITECH GROUP WWW.GRAVITECH.US

MR-BusIO-SSRAC™ BusIO Solid State Relay BOARD User Manual

Description

The MR-BusIO-SSRAC is an experiment board for switching AC output voltage by using SSR (Solid State Relay). SSR is similar to mechanical relay that consists of inductor and surface contact. The internal structure of SSR uses semiconductor material to switching ON and OFF. The maximum controlling voltage is 400VAC at 6A. It is best for switching AC output voltage.

The board can be use with MR-BusIO-MAIN board or stand-alone. PCB size is 0.63" x 2.80"

Operation:

General structure of SSR is shown in figure 1. Voltage applied to the input of an SSR causes the LED to shine on the photo-sensitive diode. The voltage is causing the TRIAC to turn on.

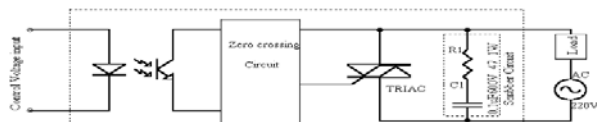

FIG 1: General structure of SSR

The board consists of MOC3042 IC which internally combined photo-coupler and zero crossing circuit together. The function of zero crossing circuit is to detect the voltage at zero point and supply current to the gate of the TRIAC. For 330ohm resistor and 0.1uF capacitor at the gate of the TRIAC, their function is sharing the current at the gate so they are not too high. Also, protect external noise into circuit.

The circuit is operating with AC voltage only. It is start when applying logic HIGH to an I/O pin. The indicator LED then illuminated which mean it is now close circuit.

User can connect AC load up to 400VAC at 6A through output 2-PIN terminal block. In case of interfacing with inductance load such as motor, user should add Snubber circuit by putting R1 47ohm 1W resistor and C1 0.1uF 600V capacitor as shown in Figure 1.



Copyright 2006 All Rights Reserved

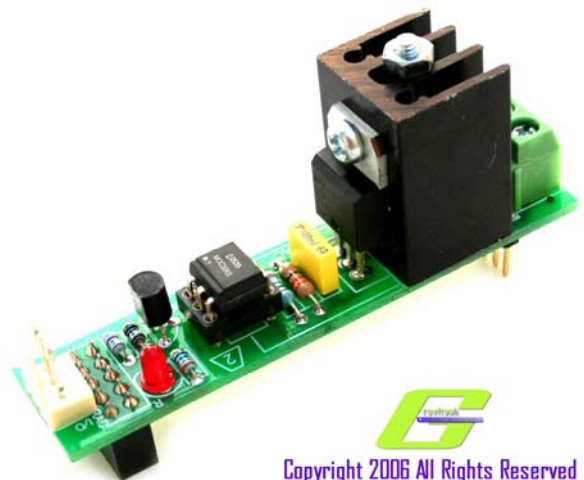

Copyright 2006 All Rights Reserved

MR-BusIO-SSRAC™ BusIO Solid State Relay BOARD User Manual

MR-BusIO-MAIN

The MR-BusIO-MAIN is available for purchase via our website. If you don't see the item you need, please contract our sales department at sales@gravitech.us

- **MR-BusIO-MAIN**

Experiment board which receives output signals from any microcontrollers. The signals then distribute to daughter boards for each experiment. It designed to connect directly with 10PIN MRconnect®. It is a quick and easy way to control up to 8 daughter boards.

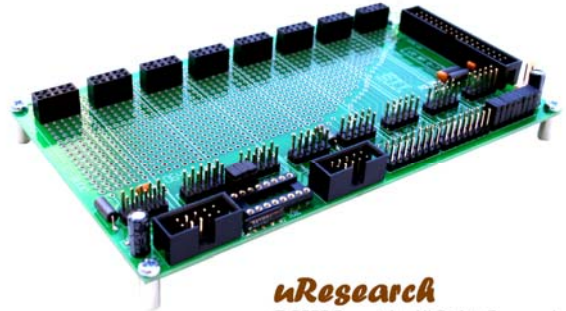

uResearch
© 2007 Copyright, All Rights Reserved

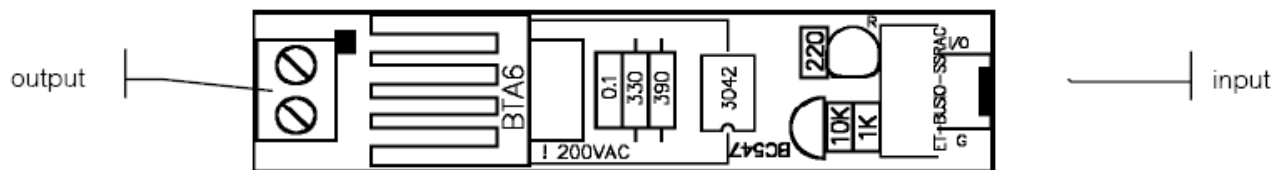

FIG 2: MR-BusIO-SSRAC Board Layout

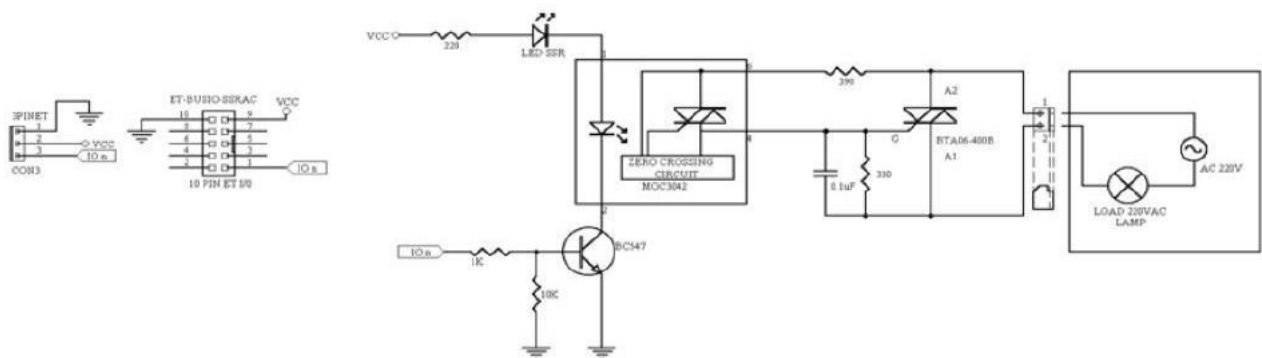

FIG 3: MR-BusIO-SSRAC Schematic