

Interface RF Connector with Switch, built-in interlock, DC to 3GHz

MS-151NB Series

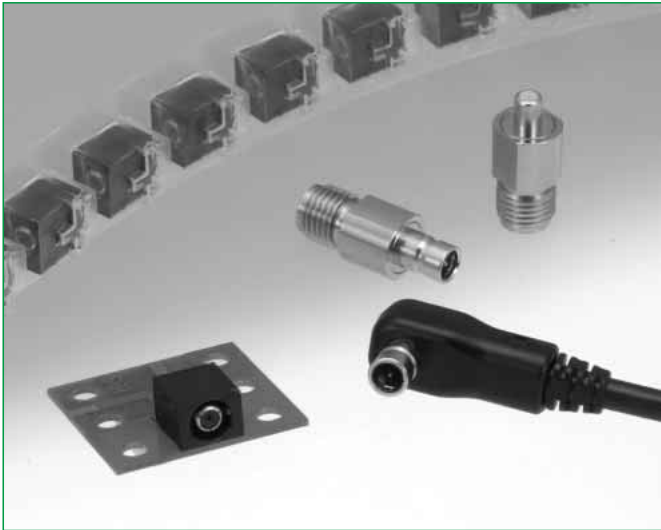

Overview

Designed for end user applications requiring re-direction of transmission from internal built-in antenna to the external antenna. Small size, lightweight and high reliability makes it ideal for use in 2.4 GHz band wireless LAN applications.

Features

1. Confirmation of complete connection

Built-in interlock feature confirms fully mated condition with a "click" sensation.

2. Non-directional connection

The connector can be mated in any position on a 360° axis and can rotate within the same when in use, allowing routing of the connected cable in any direction.

3. High durability

Guaranteed 5000 insertion/removal cycles.

4. Space-saving

The external dimensions of the board-mounted receptacle (5.0 mm high, 6.5 mm wide, 7.0 mm deep) makes it ideal for use in small devices.

5. Board placement with automatic equipment

Packaged on tape-and-reel. Also available with a vacuum pick-up cap over each switch.

6. RoHS compliant

All components and materials comply with the requirements of the EU Directive 2002/95/EC.

Applications

GPS terminals, wireless LAN modules, notebook computers, PDA, and other high frequency equipment.

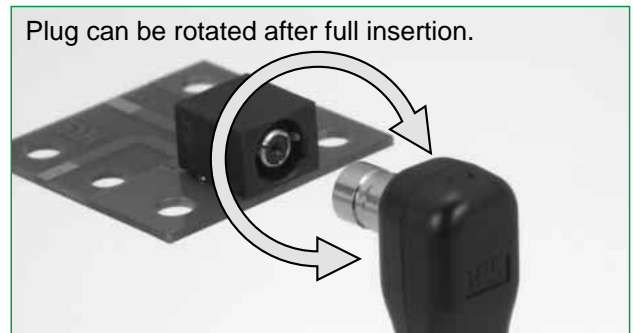

Plug can be rotated after full insertion.

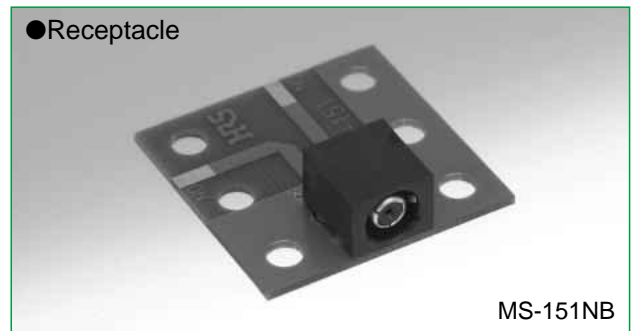

● Receptacle

MS-151NB



● Plug

MS-151-C(LP)



● SMA Conversion Adapter
For Receptacle: MS-151NB

MS151P-HRMJ



● SMA Conversion Adapter
For Plug: MS-151-C(LP)

MS151J-HRMJ

Product Specifications

Frequency range	DC to 3GHz		
Operating temperature range	-40°C to +85°C		
Power rating	4W		
		N.C	N.O
V.S.W.R.	DC to 1 GHz	1.2 max.	
	1 GHz to 2 GHz	1.4 max.	
	2 GHz to 3 GHz	1.7 max.	
Insertion loss	DC to 1 GHz	0.2dB max.	0.3dB max.
	1 GHz to 2 GHz	0.4dB max.	0.5dB max.
	2 GHz to 3 GHz	0.6dB max.	1.0dB max.
Isolation loss	DC to 1 GHz	————	20dB min.
	1 GHz to 2 GHz	————	18dB min.
	2 GHz to 3 GHz	————	12dB min.

Item	Specification	Conditions
1. Contact resistance	50 m ohms max.	100 mA
2. Insulation resistance	1000 M ohms min.	100 V DC
3. Withstanding voltage	No flashover or insulation breakdown	100 V AC / 1 minute
4. Vibration	No electrical discontinuity of 10 μ s or more	Frequency: 10 to 500 Hz, single amplitude of 0.75 mm, acceleration of 98 m/s ² for 2 hours in each of the 3 directions
5. Shock		Acceleration of 490 m/s ² , 11 ms duration, sine half-wave waveform, 3 cycles in each of the 3 axis
6. Temperature cycle	Contact resistance: 100 m ohms max. Insulation resistance: 10 M ohms min.	Temperature: -55°C → +15°C to +35°C → +85°C → +15°C to +35°C Time: 30 → 5 max. → 30 → 5 max. (Minutes) 100 cycles
7. Humidity (Steady state)		96 hours at temperature of 40°C and humidity of 90%
8. Salt spray	Contact resistance: 100 m ohms max. No corrosions	5% salt water solution, 48 hours (at 35°C)
9. Insertion/Withdrawal forces	Insertion force: 1~10N Withdrawal force: 3~15N	With corresponding connector
10. Durability (insertion/ withdrawal)	Contact resistance: 100 m ohms max.	5000 cycles

Materials

Receptacle MS-151NB

Part	Material	Finish
Insulator	Polyamide (UL94V0)	————
Lock mating section	Stainless steel	Nickel plating (Termination area: Gold-lead plated)
Outer conductor shell	Phosphor bronze	Nickel plating (Termination area: Gold-lead plated)
Contact A	Phosphor bronze	Gold plating
Contact C	Beryllium copper	Gold plating

Plug MS-151-C(LP)

Part	Material	Finish
Cover A	PC	————
Cover B	PC	————
Ring	Stainless steel	Nickel plating
Outer conductor shell	Phosphor bronze	Nickel plating
Inner contact	Phosphor bronze	Gold plating
Insulator	Polyamide (UL 94-HB)	————
Ferrule	Stainless steel	————
Crimp metal fitting	Brass	Nickel plating
Bushing	Polyester	————

◆ Typical data

● NORMALLY CLOSED(N.C) ~ (Not mated with the plug)

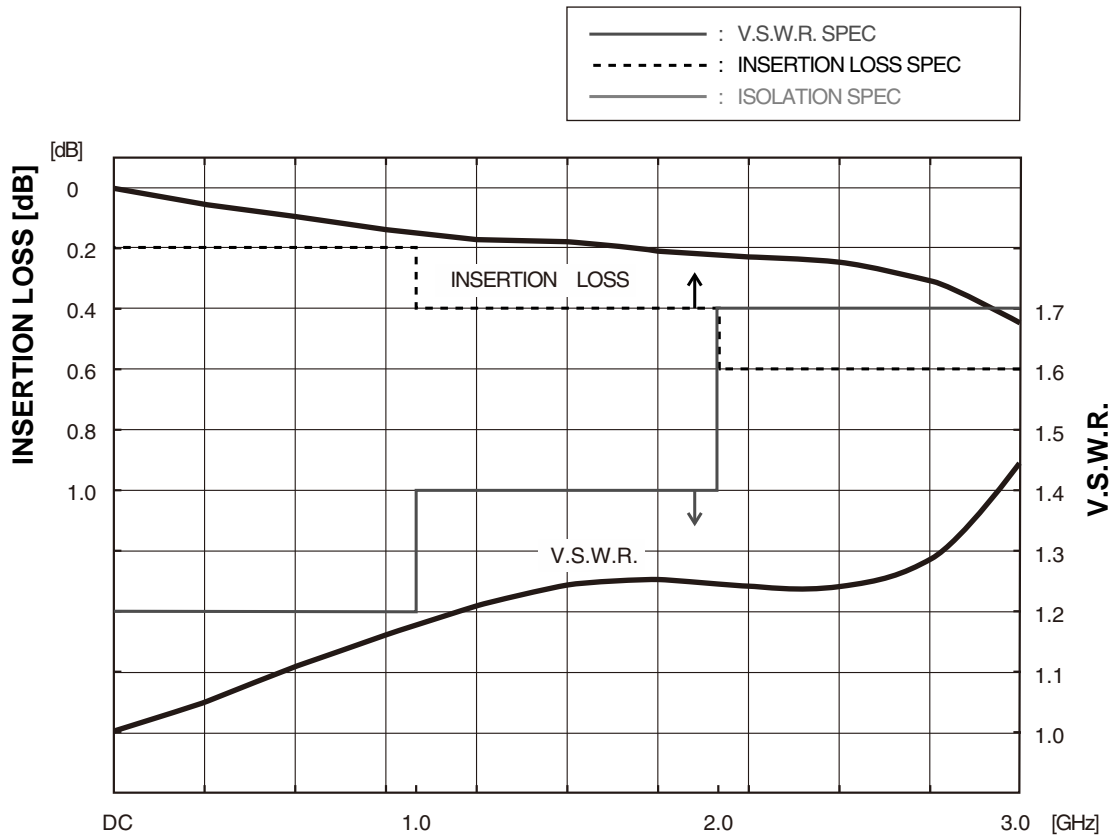

● OPEN(N.O) ~ (Mated with the plug)

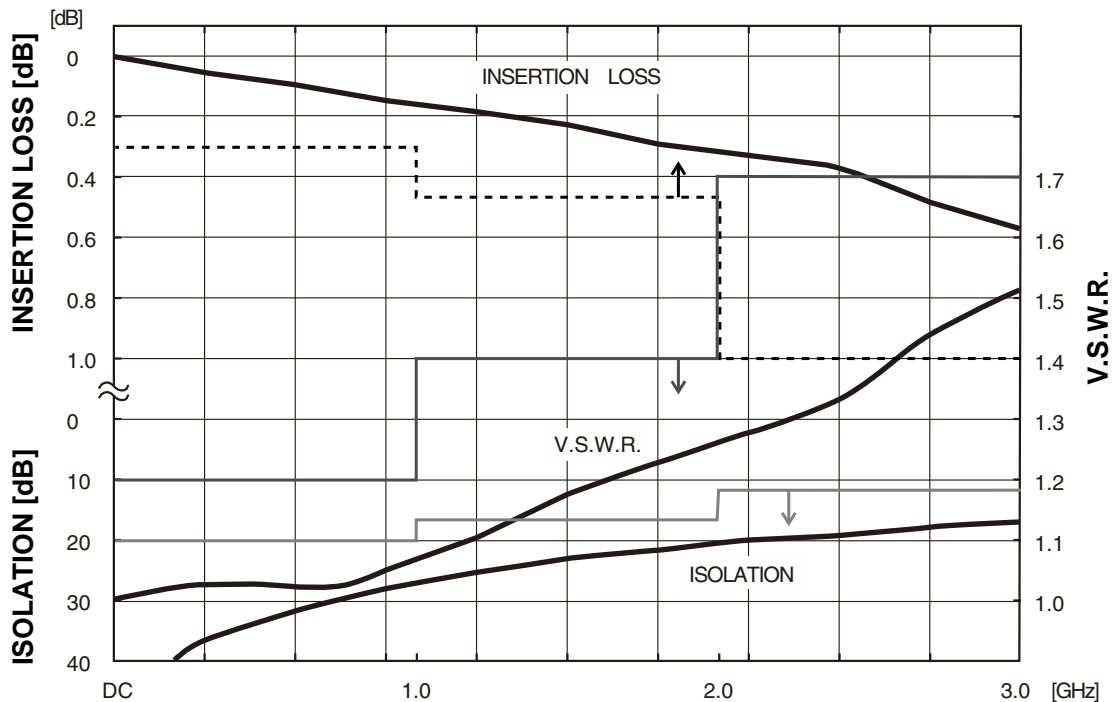

Receptacle

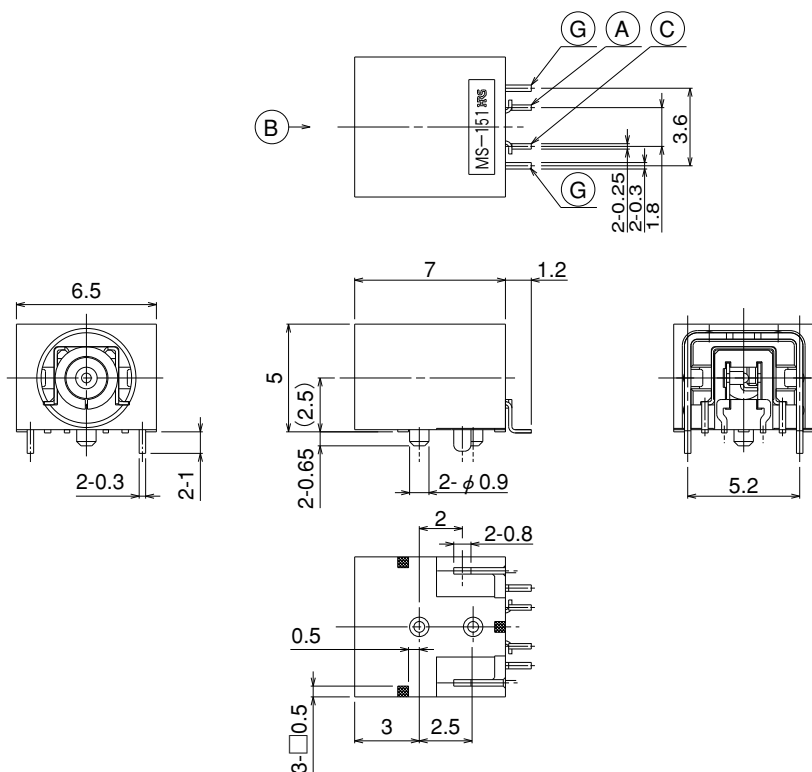
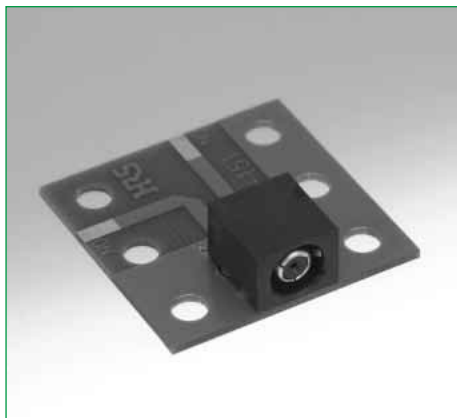

Part Number	HRS No.	Packaging	RoHS
MS-151NB	358-0215-9	1,000 pieces per reel	YES
MS-151NB(01)	358-0215-9-01	100 pieces	

Circuit diagram

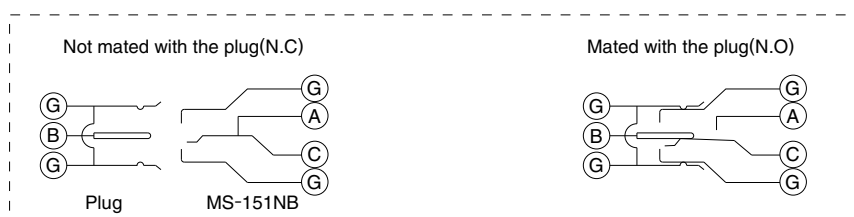

PCB mounting pattern

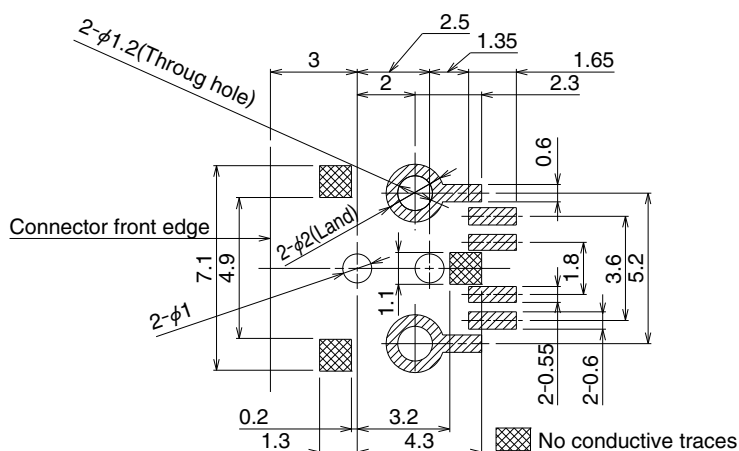

◆ Packaging Specifications

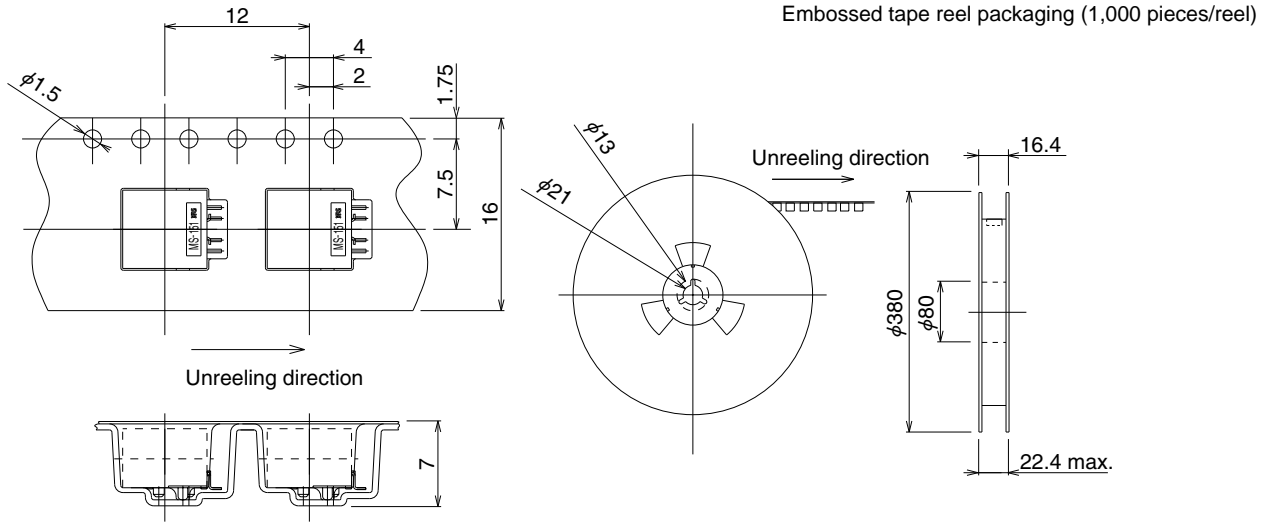

◆ Recommended Temperature Profile

Using Lead-free solder paste

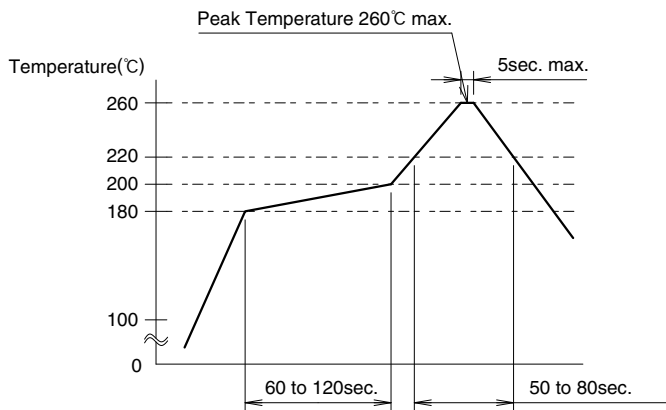

Maximum temperature	: 260°C
Peak temperature	: 240°C to 255°C
Peak temperature duration	: 5 sec. Max.
200°C min.	: 50 to 80 sec.
150°C to 160°C	: 60 to 120sec.