

MSCDC150KK170D1PAG

Datasheet

**Dual Common Cathode SiC Diodes Power
Module**

December 2019



a  **MICROCHIP** company

Contents

Revision History.....	1
1.1 Revision 1.0.....	1
Product Overview.....	2
2.1 Features.....	2
2.2 Benefits.....	2
2.3 Applications.....	3
Electrical Specifications.....	4
3.1 Absolute Maximum Ratings.....	4
3.2 Electrical Performance.....	4
3.3 Performance Curves.....	5
Package Specifications.....	6
4.1 Package Outline Drawing.....	6

1 Revision History

The revision history describes the changes that were implemented in the document. The changes are listed by revision, starting with the most current publication.

1.1 Revision 1.0

Revision 1.0 was published in December 2019. It is the first publication of this document.

2 Product Overview

This section shows the product overview of the MSCDC150KK170D1PAG device.

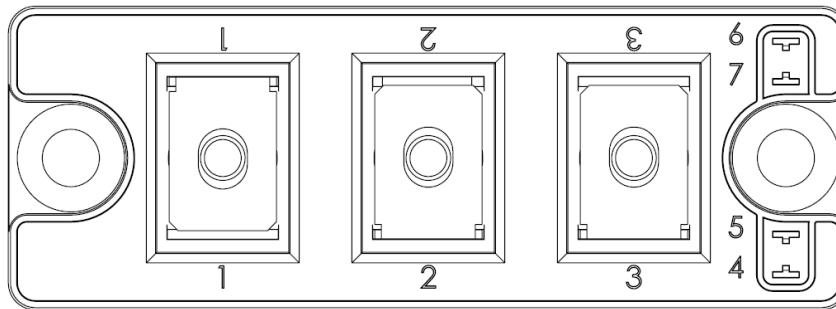
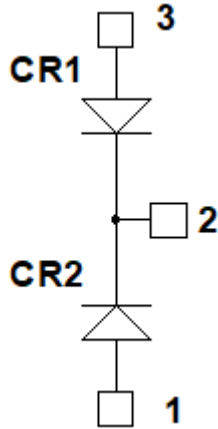

All ratings at $T_j = 25\text{ }^\circ\text{C}$, unless otherwise specified.

Caution: These devices are sensitive to electrostatic discharge. Proper handling procedures should be followed.

2.1 Features

The following are key features of the MSCDC150KK170D1PAG device:

- Silicon Carbide (SiC) Schottky Diode
 - Zero reverse recovery
 - Zero forward recovery
 - Temperature independent switching behavior
 - Positive temperature coefficient on VF
- M5 power connectors
- Aluminum nitride (AlN) substrate for improved thermal performance

2.2 Benefits

The following are benefits of the MSCDC150KK170D1PAG device:

- Stable temperature behavior
- Low losses

- Direct mounting to heatsink (isolated package)
- Low junction-to-case thermal resistance
- RoHS compliant

2.3 Applications

The MSCDC150KK170D1PAG device is designed for the following applications:

- Uninterruptible power supply (UPS)
- Switched mode power supplies
- Welding converters
- Motor control

3 Electrical Specifications

This section shows the electrical specifications of the MSCDC150KK170D1PAG device.

3.1 Absolute Maximum Ratings

The following table shows the absolute maximum ratings per SiC diode of the MSCDC150KK170D1PAG device.

Table 1 • Absolute Maximum Ratings

Symbol	Parameter	Max Ratings	Unit
V_{RRM}	Repetitive peak reverse voltage	1700	V
I_F	DC forward current	$T_C = 125\text{ }^\circ\text{C}$ 150	A

The following table shows the thermal and package characteristics of the MSCDC150KK170D1PAG device.

Table 2 • Thermal and Package Characteristics

Symbol	Characteristic	Min	Max	Unit		
V_{ISOL}	RMS isolation voltage, any terminal to case $t = 1$ minute, 50 Hz/60 Hz	4000		V		
T_J	Operating junction temperature range	-40	175	$^\circ\text{C}$		
T_{JOP}	Recommended junction temperature under switching conditions	-40	$T_{Jmax} - 25$			
T_{STG}	Storage temperature range	-40	125			
TC	Operating case temperature	-40	125			
Torque	Mounting torque	For terminals	M5	2	3.5	N.m
		To heatsink	M6	3	5	
Wt	Package weight			160	g	

3.2 Electrical Performance

The following table shows the electrical characteristics per SiC diode of the MSCDC150KK170D1PAG device.

Table 3 • Electrical Characteristics

Symbol	Characteristic	Test Conditions	Min	Typ	Max	Unit	
V_F	Diode forward voltage	$I_F = 150\text{ A}$	$T_J = 25\text{ }^\circ\text{C}$		1.5	1.8	V
			$T_J = 175\text{ }^\circ\text{C}$		2		
I_{RM}	Reverse leakage current	$V_R = 1700\text{ V}$	$T_J = 25\text{ }^\circ\text{C}$		150	600	μA
			$T_J = 175\text{ }^\circ\text{C}$		750		

Symbol	Characteristic	Test Conditions	Min	Typ	Max	Unit
Q_C	Total capacitive charge	$V_R = 900\text{ V}$		1230		nC
C	Total capacitance	$f = 1\text{ MHz}, V_R = 600\text{ V}$		900		pF
		$f = 1\text{ MHz}, V_R = 900\text{ V}$		750		
R_{thJC}	Junction-to-case thermal resistance				0.121	$^{\circ}\text{C/W}$

3.3 Performance Curves

This section shows the typical performance curves for the MSCDC150KK170D1PAG device.

Figure 1 • Maximum Thermal Impedance

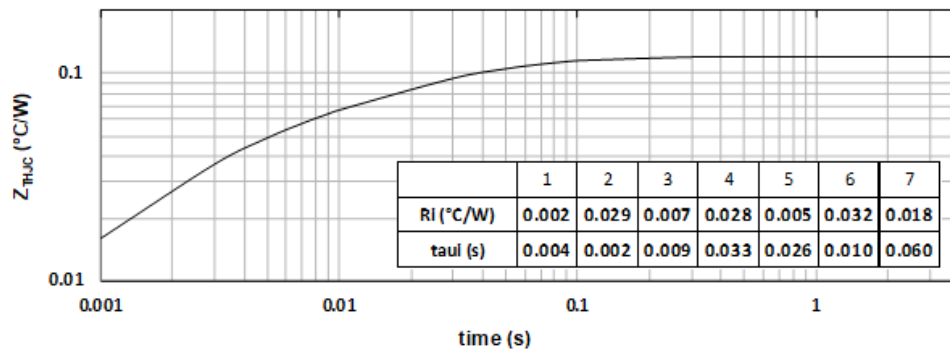

Figure 2 • Forward Characteristics

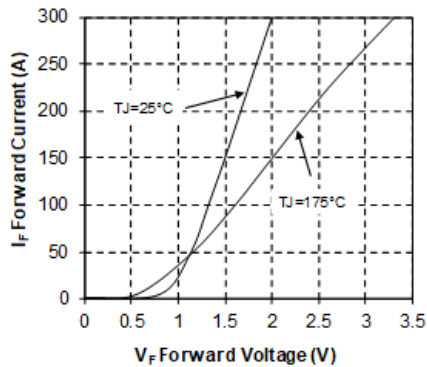
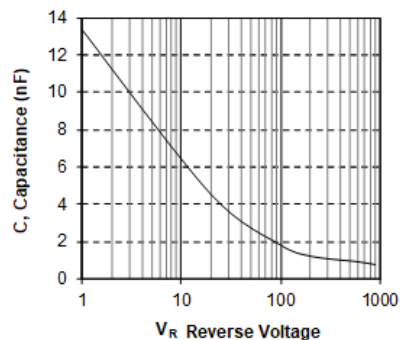

Figure 3 • Capacitance vs. Reverse Voltage



4 Package Specifications

This section shows the package specifications of the MSCDC150KK170D1PAG device.

4.1 Package Outline Drawing

This section shows the package outline drawing of the MSCDC150KK170D1PAG device. The dimensions in the following figure are in millimeters.

Figure 4 • Package Outline Drawing

