



Mallory Sonalert Products, Inc.

Part #:

MSS300R

Sales Outline Drawing

Revision:

L

cUL Recognized as capable of meeting Medical Spec IEC60601-1-8 AMD2:2020

Specifications:

Coil Impedance:	8Ω @ 1-volt
Rated Wattage:	0.25 Watts (2Vp-p Sine Wave, 176mA)
Max Wattage:	0.5 Watts
Loudness @ 10cm:	85 to 95 dB(A) Typ.
Recommended Drive Frequency:	325 Hz
Harmonics Present:	4 peaks within ± 15dB from 1 - 4 kHz
Housing Material:	Valox (UL94V-0), Octagonal, Black
Storage Temperature:	-40° to +85° C
Operating Temperature:	-30° to +65° C
cUL Recognition:	Approved as of Code Date: 1548 3
Weight Typical:	5.0g
Options:	Please contact factory.

Dimensions:

Inches (mm)

cUL Recognized

ROHS Compliant

PATENT NUMBER: 7880593

Before Code Date:

1546 Not cUL Recognized

After Code Date:

1547 cUL Recognized

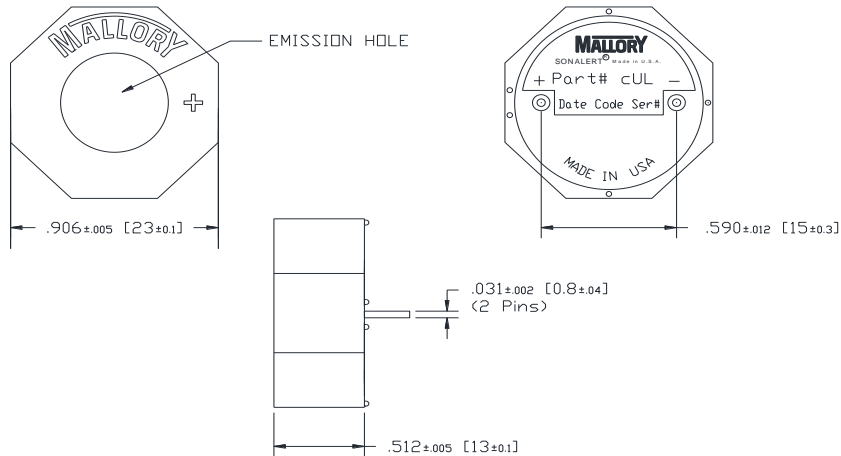
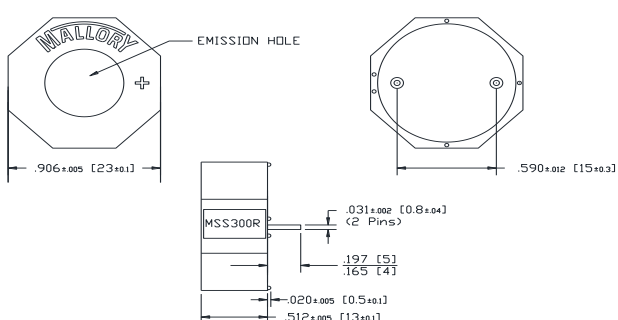

NOTE A:
TERMINALS - .031" DIA. NICKEL/TIN COATED BRASS.
NOTE B:
MOUNTING- INSERT INTO PRINTED CIRCUIT BOARD AND HAND OR MACHINE SOLDER.
UNITS ARE SUITABLE FOR WAVE SOLDERING. BOARDS ARE NOT SUITABLE FOR WASH.
RECOMMENDED MAXIMUM TEMPERATURE AND TIME DURATION FOR WAVE SOLDERING IS
+270°C AND 3 SECONDS RESPECTIVELY.

NOTE A:
TERMINALS - .031" DIA. NICKEL/TIN COATED BRASS.
NOTE B:
MOUNTING- INSERT INTO PRINTED CIRCUIT BOARD AND HAND OR MACHINE SOLDER.
UNITS ARE SUITABLE FOR WAVE SOLDERING. BOARDS ARE NOT SUITABLE FOR WASH.
RECOMMENDED MAXIMUM TEMPERATURE AND TIME DURATION FOR WAVE SOLDERING IS
+270°C AND 3 SECONDS RESPECTIVELY.