

Features

- Wide Frequency Range: 50 MHz to 4 GHz, in 2 bands
- Surface Mount SP2T Switch in Compact Outline: 8 mm L x 5 mm W x 2.5 mm H
- Higher Average Power Handling than Plastic Packaged
- MMIC Switches: 158 W CW
- High RF Peak Power: 630 W
- Low Insertion Loss: 0.25 dB
- High IIP3: 65 dBm
- Operates From Positive Voltage Only: 5 V & 28 V to 125 V
- Ultra-Thin Termination Plating to Combat Embrittlement
- RoHS* Compliant

Description

The MSW2050-205 (50 MHz - 1 GHz) and MSW2051-205 (400 MHz - 4 GHz) series of surface mount silicon PIN diode SP2T switches can be used for high power transmit/receive (TR) switching or active receiver protection. These switches are manufactured using a proven hybrid manufacturing process incorporating high voltage PIN diodes and passive devices integrated on a ceramic substrate. These low profile, compact, surface mount components offer superior small and large signal performance compared to that of MMIC devices in QFN packages. The SP2T switches are designed in an asymmetrical topology to minimize Tx-Ant loss and maximize Tx-Rx isolation performance. The very low thermal resistance (<15°C/W) of the PIN diodes in these devices enables them to reliably handle RF incident power levels of 50 dBm CW and RF peak incident power levels of 58 dBm in cold switching applications at $T_A = 25^\circ\text{C}$. The low PIN diode series resistance (<1.0 Ω), coupled with their long minority carrier lifetime, (>1.5 μs), provides input third order intercept point (IIP3) greater than 65 dBm.

These MSW2050-205, MSW2051-205 SP2T switches are designed to be used in high average and peak power switch applications, operating from 50 MHz to 4 GHz in two bands, which utilize high volume, surface mount, solder re-flow manufacturing. These products are durable and capable of reliably operating in military, commercial, and industrial environments.

Functional Schematic

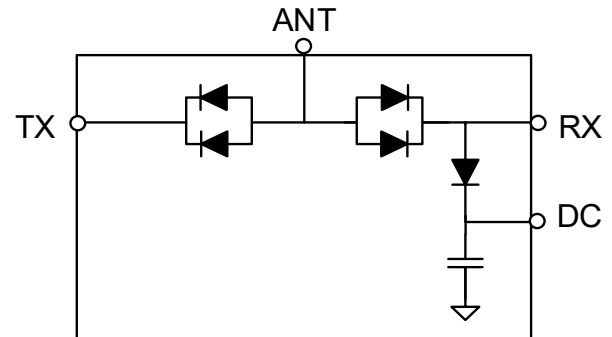

Ordering Information

| Part Number | Package |
|---------------|-----------------------|
| MSW2050-205-T | tube |
| MSW2050-205-R | 250 or 500 piece reel |
| MSW2050-205-W | Waffle pack |
| MSW2051-205-T | tube |
| MSW2051-205-R | 250 or 500 piece reel |
| MSW2051-205-W | Waffle pack |
| MSW2050-205-E | RF evaluation board |
| MSW2051-205-E | RF evaluation board |

* Restrictions on Hazardous Substances, compliant to current RoHS EU directive.

MSW2050-205 Electrical Specifications: $T_A = +25^\circ\text{C}$, $P_{IN} = 0 \text{ dBm}$, $Z_0 = 50 \Omega$

| Parameter | Test Conditions | Units | Min. | Typ. | Max. |
|-----------------------------------|--|---------------|----------|--------------|--------------|
| Frequency | — | MHz | 50 | — | 1000 |
| Insertion Loss | Condition 1 Condition 2 | dB | — | 0.15 0.25 | 0.25 0.35 |
| Return Loss | Condition 1 Condition 2 | dB | 18 20 | 20 22 | — |
| Isolation | Condition 1 Condition 2 | dB | 47 23 | 50 26 | — |
| TX CW Incident Power ¹ | Condition 1, Source & Load VSWR = 1.5:1 | dBm | — | — | 52 |
| RX CW Incident Power ¹ | Condition 2, Source & Load VSWR = 1.5:1 | dBm | — | — | 43 |
| Peak Incident Power ¹ | Source & Load VSWR = 1.5:1 Pulse Width = 10 μs , Duty Cycle = 1% | dBm | — | — | 58 |
| Switching Time ² | 10% -90% RF Voltage, TTL rep rate = 100 kHz | μs | — | 2 | 3 |
| Input IP3 | F1 = 500 MHz, F2 = 510 MHz P1 = P2 = 40 dBm | dBm | 60 | 65 | — |

MSW2051-205 Electrical Specifications: $T_A = +25^\circ\text{C}$, $P_{IN} = 0 \text{ dBm}$, $Z_0 = 50 \Omega$

| Parameter | Test Conditions | Units | Min. | Typ. | Max. |
|---------------------------------------|--|---------------|----------|------------|------------|
| Frequency | — | MHz | 400 | — | 4000 |
| Insertion Loss | Condition 1 Condition 2 | dB | — | 0.3 0.8 | 0.4 0.9 |
| Return Loss | Condition 1 Condition 2 | dB | 15 15 | 17 17 | — |
| Isolation | Condition 1 Condition 2 | dB | 32 11 | 34 13 | — |
| TX CW Incident Power ¹ | Condition 1, Source & Load VSWR = 1.5:1 | dBm | — | — | 52 |
| RX CW Incident Power ¹ | Condition 2, Source & Load VSWR = 1.5:1 | dBm | — | — | 43 |
| Peak Incident Power ¹ | Source & Load VSWR = 1.5:1 Pulse Width = 10 μs , Duty Cycle = 1% | dBm | — | — | 58 |
| Switching Time ² T-Rise | 10% -90% RF Voltage, TTL rep rate = 100 kHz | μs | — | 1.5 | 2.0 |
| Input IP3 | F1 = 2.0 GHz, F2 = 2.01 GHz P1 = P2 = 40 dBm | dBm | 60 | 65 | — |

- PIN diode minimum reverse DC voltage (V_{HIGH}) to maintain high resistance in the OFF PIN diode is determined by RF frequency, incident power, duty cycle, characteristic impedance and VSWR as well as by the characteristics of the diode. The recommended minimum reverse bias voltage (V_{HIGH}) values are provided in the Minimum Reverse Bias Voltage table of this datasheet.
- Switching time (10/90% RF Voltage t-rise and 90/10% RF Voltage t-fall) is a function of the PIN diode driver performance as well as the characteristics of the diode. An RC "current spiking network" is used on the driver output to provide a transient current to rapidly remove stored charge from the PIN diode. Typical component values are: R = 50 to 220 Ω and C = 470 to 1,000 pF.

Evaluation Board Truth Table^{3,4}

| Bias State | RF State | Ant Bias (P1-pin 3) | TX Bias (P1-pin 1) | RX Bias (P1-pin 7) | DC Bias (P1-pin 5) |
|-------------|-----------------------------------|---------------------|--------------------|--------------------|--------------------|
| Condition 1 | TX-ANT Low Loss & TX-RX Isolation | +5 V @ +100 mA | 0 V @ +100 mA | +28 V @ +25 mA | 0 V @ +25 mA |
| Condition 2 | ANT-RX Low Loss & RX-TX Isolation | +5 V @ +100 mA | +28 V @ 0 mA | 0 V @ +100 mA | +28 V @ 0 mA |

3. 28 V <= V_{HIGH} <= 125 V.

4. PIN diode minimum reverse DC voltage (V_{HIGH}) to maintain high resistance in the OFF PIN diode is determined by RF frequency, incident power, duty cycle, characteristic impedance and VSWR as well as by the characteristics of the diode. The recommended minimum reverse bias voltage (V_{HIGH}) values are provided in the Minimum Reverse Bias Voltage table of this datasheet.

RF Bias Network Component Values

| Part # | Frequency (MHz) | Inductors | DC Blocking Capacitors | RF Bypass Capacitors |
|-------------|-----------------|-----------|------------------------|----------------------|
| MSW2050-205 | 50 - 1000 | 4.7 μH | 0.1 μF | 0.1 μF |
| MSW2051-205 | 400 - 4000 | 82 nH | 27 pF | 270 pF |

Minimum Reverse Bias Voltage⁵

P_{INC} = 125 W CW, Z₀ = 50 Ω with 1.5:1 Combined Source and Load VSWR

| Part # | 20 MHz | 100 MHz | 200 MHz | 400 MHz | 1 GHz | 4 GHz |
|-------------|--------|---------|---------|---------|-------|-------|
| MSW2050-205 | 125 V | 125 V | 85 V | 55 V | 28 V | N/A |
| MSW2051-205 | N/A | N/A | 125 V | 85 V | 55 V | 28 V |

5. N/A denotes the switch is not recommended for that frequency band.

The minimum reverse bias voltage required to maintain a PIN diode out of conduction in the presence of a large RF signal is given by:

$$|V_{DC}| = \frac{|V_{RF}|}{\sqrt{1 + \left[\left(\frac{0.0142 \times f_{MHz} \times W_{mils}^2}{V_{RF} \times \sqrt{D}} \right) \times \left(1 + \sqrt{1 + \left(\frac{0.056 \times V_{RF} \times \sqrt{D}}{W_{mils}} \right)^2} \right)^2 \right]^2}}$$

Where:

- |V_{DC}| = magnitude of the minimum DC reverse bias voltage
- |V_{RF}| = magnitude of the peak RF voltage (including the effects of the VSWR)
- f_{MHz} = lowest RF signal frequency expressed in MHz
- D = duty factor of the RF signal
- W_{MILS} = thickness of the diode I layer, expressed in mils (thousands of an inch)

R. Caverly and G. Hiller, —Establishing the Minimum Reverse Bias for a PIN Diode in a High Power Switch, IEEE Transactions on Microwave Theory and Techniques, Vol.38, No.12, December 1990

Absolute Maximum Ratings

| Parameter | Conditions | Absolute Maximum |
|---|--|------------------|
| Forward Current | Ant, TX or RX Port DC Port | 250 mA 150 mA |
| Reverse Voltage | TX or RX Port DC Port | 200 V 200 V |
| Forward Diode Voltage | $I_F = 250 \text{ mA}$ | 1.2 V |
| CW Incident Power Handling ⁴ | TX or Ant Port Combined Source & Load VSWR = 1.5:1, $T_C = 85^\circ\text{C}$, cold switching | 52 dBm |
| CW Incident Power Handling ⁴ | RX or Ant Port Combined Source & Load VSWR = 1.5:1, $T_C = 85^\circ\text{C}$, cold switching | 43 dBm |
| Peak Incident Power Handling ⁴ | RX or Ant Port Combined Source & Load VSWR = 1.5:1, $T_C = 85^\circ\text{C}$, cold switching, Pulse Width = 10 μs , Duty Cycle = 1% | 58 dBm |
| Total Dissipated RF & DC Power ⁴ | $T_C = 85^\circ\text{C}$, cold switching | 8 W |
| Junction Temperature | — | +175°C |
| Operating Temperature | — | -55°C to +125°C |
| Storage Temperature | — | -65°C to +150°C |
| Assembly Temperature | $t = 10 \text{ s}$ | +260°C |

6. Backside RF and DC grounding area of device must be completely solder attached to the RF circuit board vias for proper electrical and thermal circuit grounding.

Handling Procedures

Please observe the following precautions to avoid damage:

Static Sensitivity

These electronic devices are sensitive to electrostatic discharge (ESD) and can be damaged by static electricity. Proper ESD control techniques should be used when handling these Class 1C (HBM) devices. The moisture sensitivity level (MSL) rating for this part is MSL 1.

Environmental Capabilities

The MSW204x-204 diode is capable of meeting the environmental requirements of MIL-STD-202 and MIL-STD-750.

Typical Performance Curves

MSW2050-205

MSW2051-205

Insertion Loss

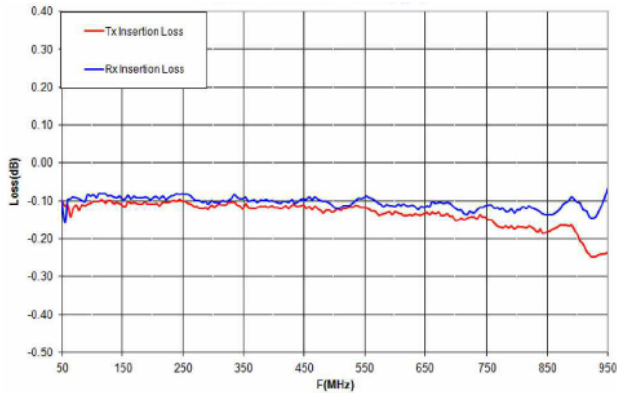

Insertion Loss

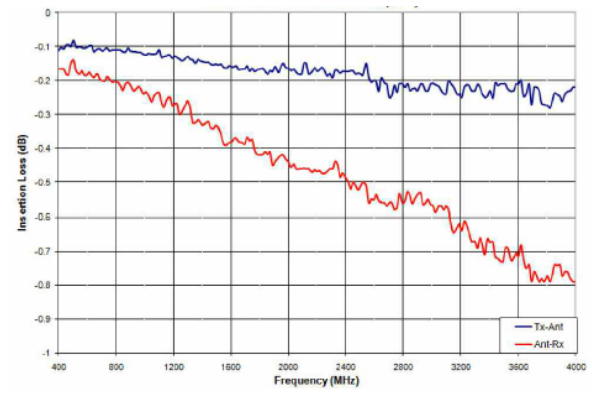

Isolation

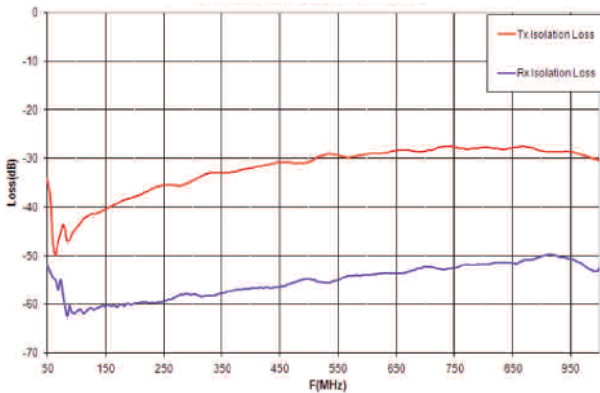

Isolation

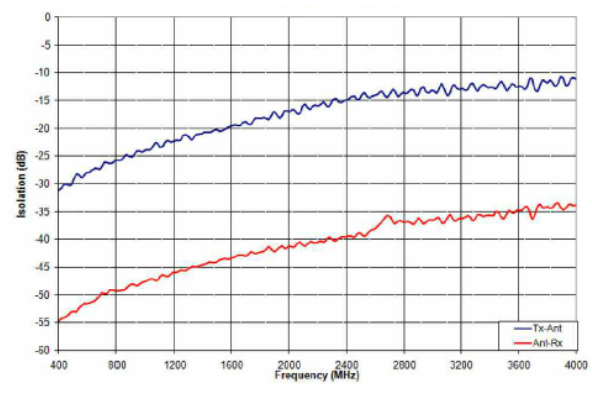

Return Loss

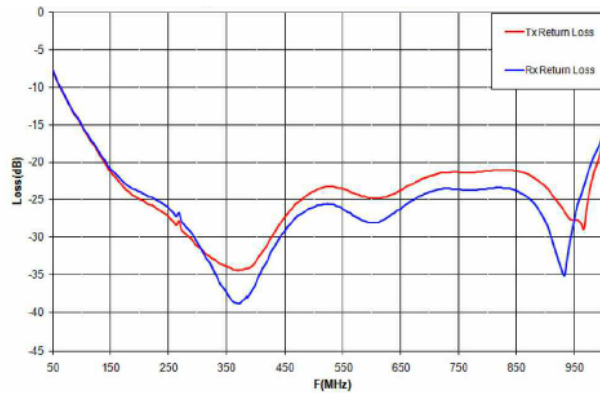

Return Loss

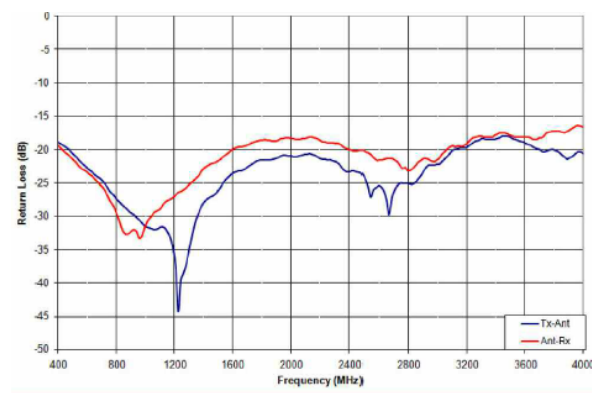

SP2T Switch Evaluation Board Schematic

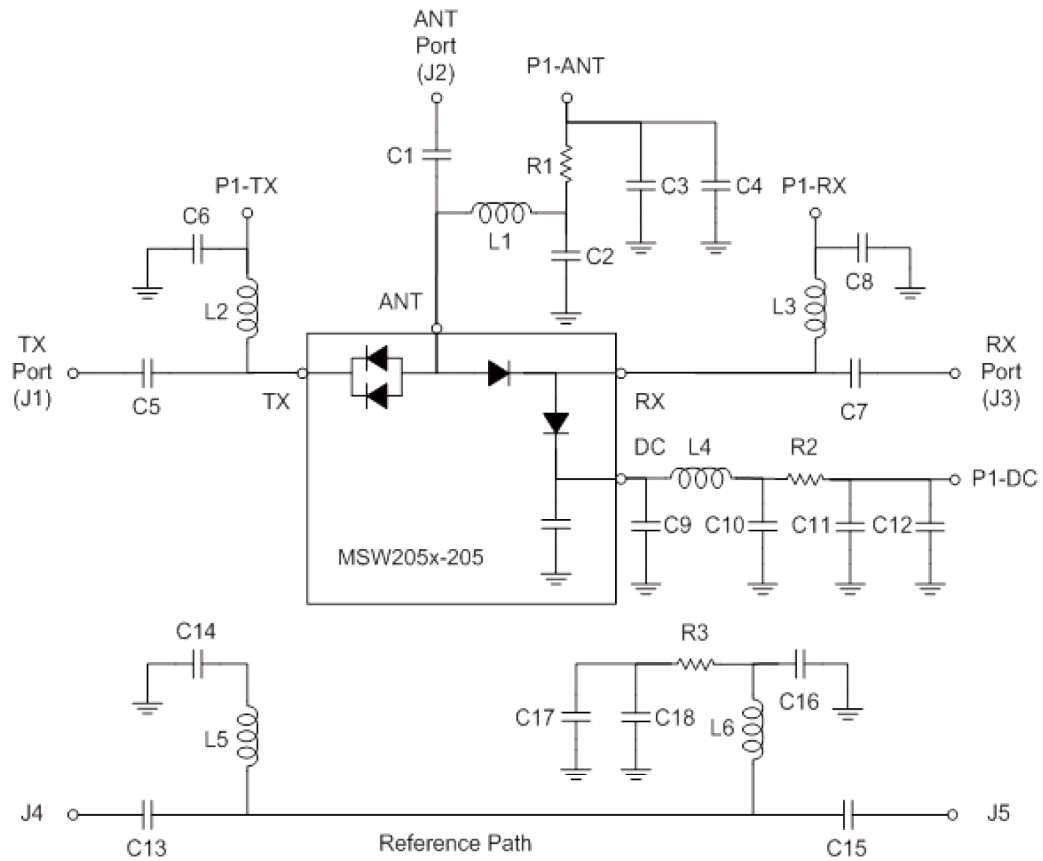

The evaluation boards for the MSW2050 family of surface mount silicon PIN diode SP2T T-R switches allow the full exercise of each switch for small signal performance analysis, as well as for large signal operation with maximum input signal power of 45 dBm (CW or peak power). Each evaluation board includes the appropriate MSW205x-205 switch, DC blocking capacitors at each RF port and bias decoupling networks at each RF port which allow DC or low frequency control signals to be applied to the switch.

Three complementary control signals are required for proper operation. Bias voltages are applied to the TX bias port, RX bias port and the DC bias port to control the state of the switch. A bias voltage of 5 V must be applied to the Ant Bias (pin 3 of multi-pin connector P1) port whenever the switch is in operation.

Transmit State

In the TX state, the series PIN diode between the ANT and TX ports is forward biased by applying 0 V to the TX bias input port (pin 1 of multi-pin connector P1). The magnitude of the resultant bias current through the diode is primarily determined by the voltage applied to the ANT bias port (pin 3 of J1), the magnitude of the forward voltage across the PIN diode and the resistance of R1. This current is nominally 100 mA. At the same time, the PIN diode connected between RX and DC ports is also forward biased by applying a higher bias voltage, nominally 28 V, to the RX bias port (pin 7 of P1) and 0 V to the DC bias port (pin 5 of P1). Under this condition, the PIN diode connected between the ANT and RX port is reverse biased and the PIN diode connected between the RX and DC ports is forward biased. The magnitude of the bias current through this diode is primarily determined by the voltage applied to the RX bias port, the magnitude of the forward voltage across the PIN diode and the resistance of R2. This current is nominally 25 mA.

The RX series PIN diode, which is connected between the ANT and RX ports, must be reverse biased during the transmit state. The reverse bias voltage must be sufficiently large to maintain the diode in its non-conducting, high impedance state when large RF signal voltage may be present in the ANT-to-TX path. The reverse voltage across this diode is the arithmetic difference of the bias voltage applied to the RX bias port and the DC forward voltage of the forward-biased transmit series PIN diode.

The minimum voltage required to maintain the series diode on the RX side of the switch out of conduction is a function of the magnitude of the RF voltage present, the standing wave present at the RX series diode's anode, the frequency of the RF signal and the characteristics of the RX series diode, among other factors. Minimum control voltages for several signal frequencies are shown in the table "Minimum Reverse Bias Voltage", assuming the input power to the RX or ANT port to be 100 W CW and the VSWR on the ANT-TX path to be 1.5:1. It is important to note that the evaluation board, as supplied from the factory, is not capable of handling RF input signals larger than 45 dBm. If performance of the switch under larger input signals is to be evaluated, an adequate heat sink must be properly attached to the

evaluation board, and several of the passive components on the board must be changed in order to safely handle the dissipated power as well as the high bias voltage necessary for proper performance. Contact the factory for recommended components and heat sink.

Receive State

In the RX state, the series PIN diode between the ANT and RX ports is forward biased by applying 0 V to the RX bias input port (pin 7 of multi-pin connector P1). The magnitude of the resultant bias current through the diode is primarily determined by the voltage applied to the ANT bias port (pin 3 of P1), the magnitude of the forward voltage across the PIN diode and the resistance of R1. This current is nominally 100 mA. At the same time, the PIN diode connected between RX and DC ports is reverse biased by applying a high bias voltage, nominally 28 V, to the DC bias port (pin 5 of P1). A high voltage, nominally 28 V, is also applied to the TX bias port (pin 1 of P1). Under this condition, the PIN diode connected between the ANT and TX port is reverse biased thus isolating the TX RF port from the RX signal path. The reverse voltage across this diode is the arithmetic difference of the bias voltage applied to the TX bias port and the DC forward voltage of the forward-biased receive series PIN diode. The minimum voltage required to maintain the series diode on the TX side of the switch out of conduction is a function of the magnitude of the RF voltage present, the standing wave present at the RX series diode's anode, the frequency of the RF signal and the characteristics of the TX series diode, among other factors. For typical receive-level signals, this diode is held out of conduction with a relatively small reverse bias voltage.

The values of the reactive components which comprise the bias decoupling networks as well as the signal path DC blocking are shown in the table RF Bias Network Component Values.

Reference Path

A reference path is provided on the evaluation board, complete with bias decoupling networks, so that the magnitude of the insertion loss of the microstrip transmission lines connected to the switch and the associated bias decoupling components can be measured and removed from the measured performance of the switch.

SP2T Switch Evaluation Board Layout

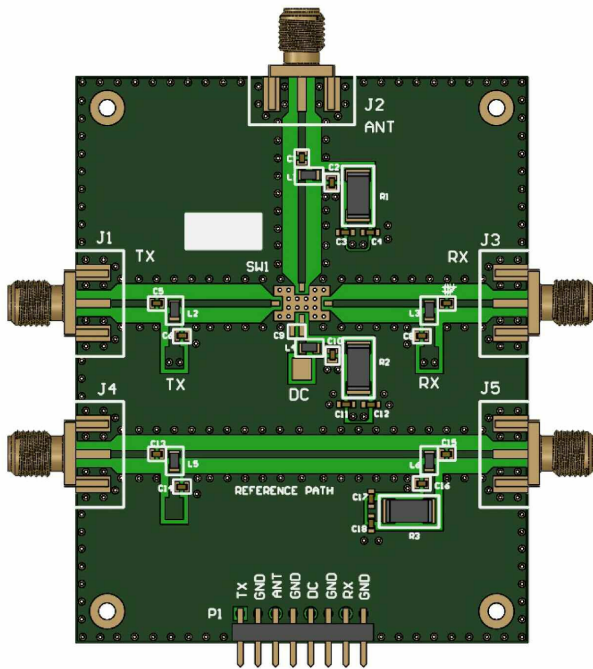

Evaluation Board Parts List

| MSW2050-205 Band 1 | | |
|---|---------------|------------|
| Part | Value | Case Style |
| C1, C2, C5 - C8, C13 - C15 | 0.1 μ F | 0603 |
| ⁷ C3, C4, C11, C12, C17, C18 | 0.1 μ F | 0603 |
| L1 - L6 | 1.7 μ H | 0603 |
| R1, R3 | 39 Ω | 2512 |
| R2 | 1200 Ω | 2512 |

| MSW2051-205 Band 2 | | |
|-------------------------------|---------------|------------|
| Part | Value | Case Style |
| C1, C5, C7, C13, C15 | 47 pF | 0603 |
| C2, C6, C8, C9, C10, C14, C16 | 220 pF | 0603 |
| C3, C4, C11, C12, C17, C18 | 1000 pF | 0603 |
| L1 - L6 | 43 nH | 0603 |
| R1, R3 | 39 Ω | 2512 |
| R2 | 1200 Ω | 2512 |

7. Second bypass capacitor is optional.

MSW205x-205 with MADR-010574 Driver Application Schematic⁸

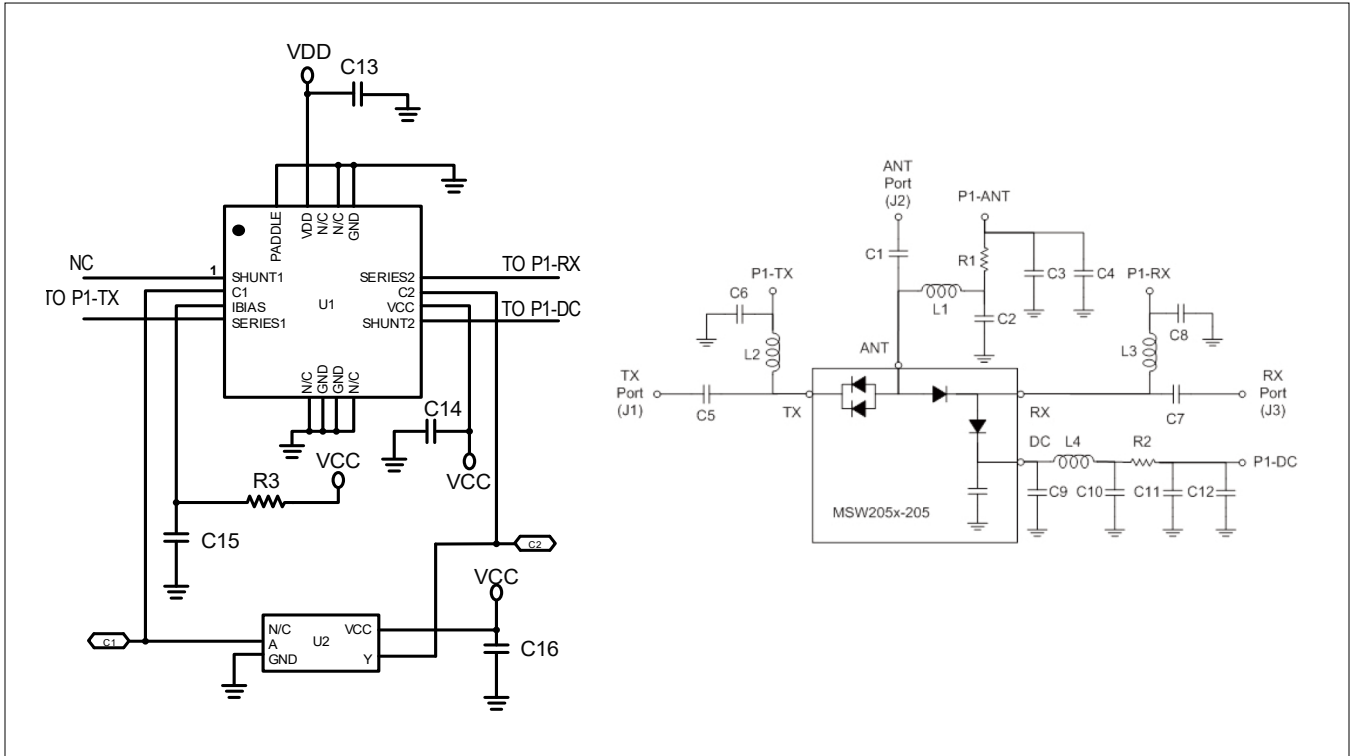

8. See page 8 for R1, L1 - L4 and C1 - C12 values. P1-ANT set to V_{CC}.

MADR-010574 Parts List

| Part | Value |
|---------------------|-----------|
| C13 | 0.01 μF |
| C14 - C16 | 0.1 μF |
| R2, R4 ⁹ | 12 KΩ |
| R3 | 499 KΩ |
| U2 | SN74AHC1G |

9. Resistor value calculated to provide ~10 mA of shunt diode bias current given V_{CC} = 5 V and V_{DD} = 120 V.

Assembly Instructions

SP2T PIN Diodes may be placed onto circuit boards with pick and place manufacturing equipment from tape and reel. The devices are attached to the circuit using conventional solder re-flow or wave soldering procedures with RoHS type or Sn 60 / Pb 40 type solders.

Table 1. Time-Temperature Profile for Sn60/Pb40 or RoHS Type Solders

| Profile Feature | SnPb Solder Assembly | Pb-Free Solder Assembly |
|--|----------------------|-------------------------|
| Average Ramp-Up Rate (T_L to T_p) | 3°C /second maximum | 3°C /second maximum |
| Preheat: | | |
| - Temperature Min (T_{SMIN}) | 100°C | 150°C |
| - Temperature Max (T_{SMAX}) | 150°C | 200°C |
| - Time (min to max)(t_s) | 60-120 s | 60-180 s |
| T_{SMAX} to T_L | | |
| - Ramp-Up Rate | | 3°C/s maximum |
| Time Maintained Above: | | |
| - Temperature (T_L) | 183°C | 217°C |
| - Time (t_L) | 60-150 s | 60-150 s |
| Peak temperature (T_p) | 225 +0/-5°C | 260 +0/-5°C |
| Time Within 5°C of Actual Peak Temperature (t_p) | 10 – 30 s | 20 – 40 s |
| Ramp-Down Rate | 6°C /s maximum | 6°C /s maximum |
| Time 25°C to Peak Temperature | 6 minutes maximum | 8 minutes maximum |

Figure 1. Solder Re-Flow Time-Temperature Profile

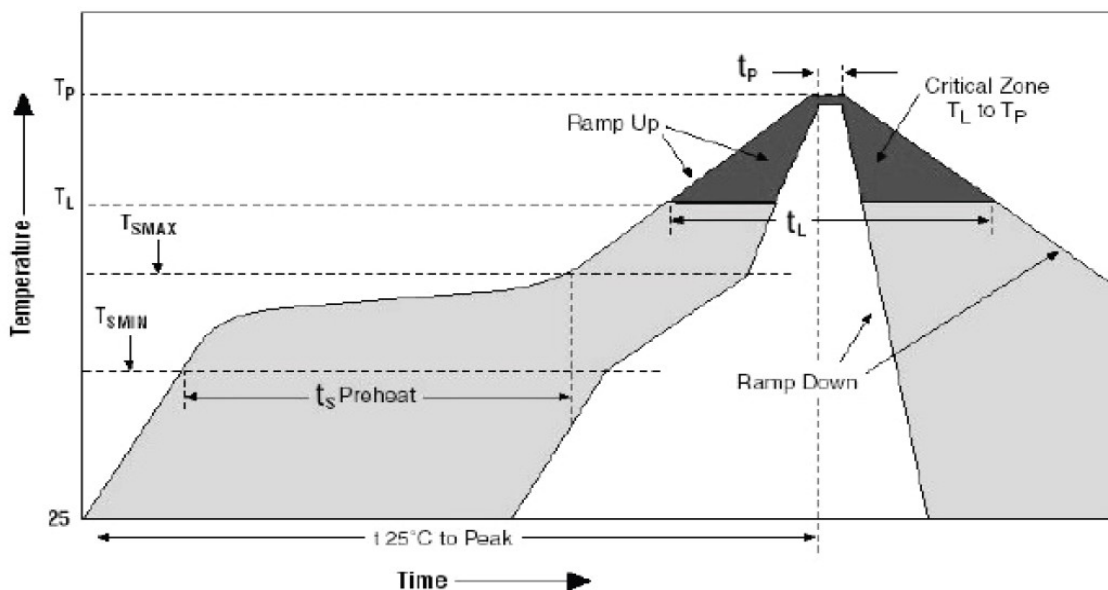

Outline (CS205)^{10,11}

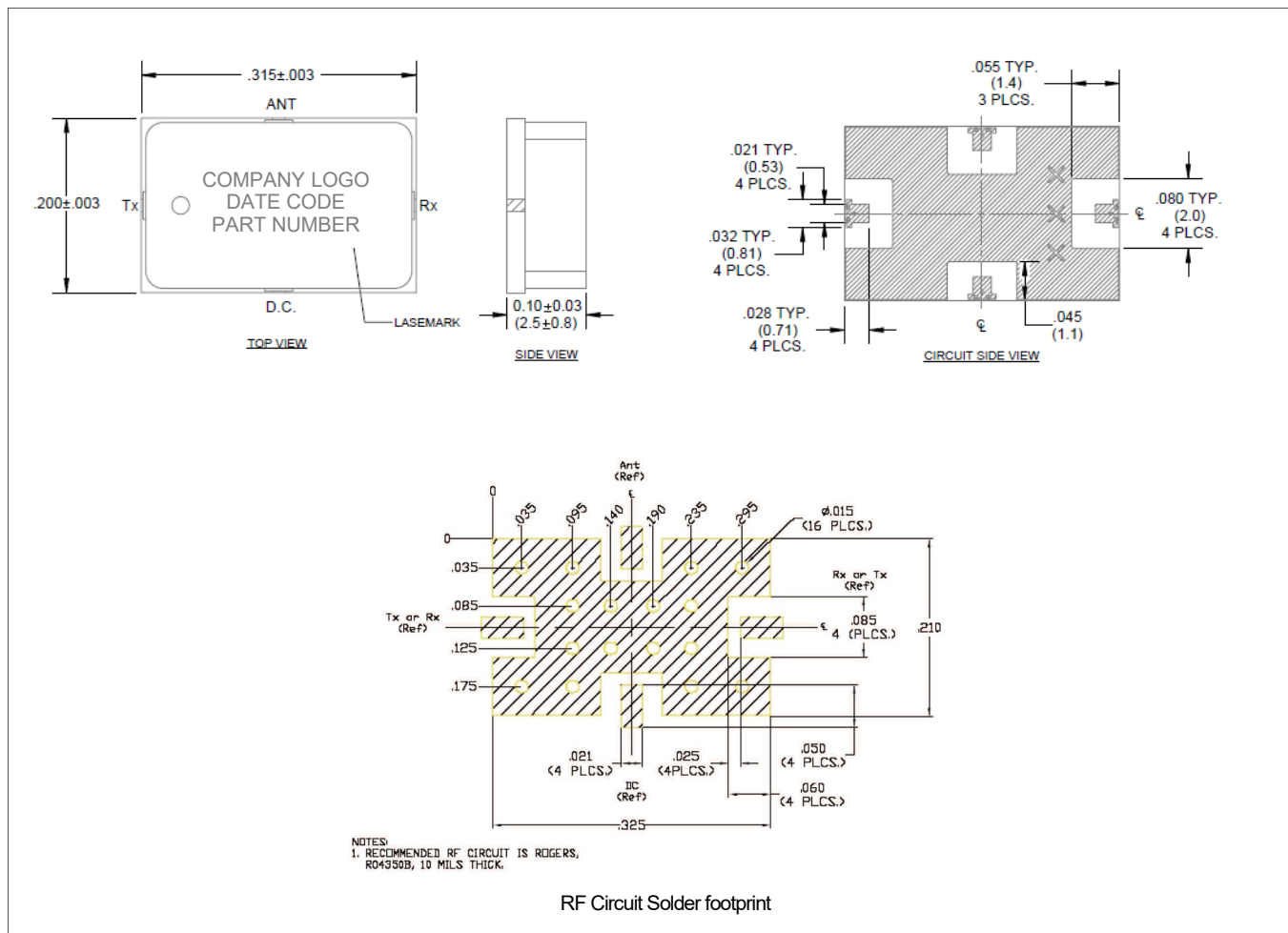

10. Hatched metal area on circuit side of device is RF, DC and thermal grounded.

11. Vias should be solid copper fill and gold plated for optimum heat transfer from backside of switch module through Circuit Vias to metal thermal ground.