

PIN Diode Shunt Switch Element

Rev. V1

Features

- Supports up to 100 W when hot switched
- Supports up to 300 W when cold switched
- Low Insertion Loss: 0.15 dB up to 2.7 GHz
- High Isolation: 31 dB up to 2.7 GHz
- RoHS* Compliant

Description

A broadband, high linearity, high power shunt switch element in a 10 x 4 mm bolt channel metal package.

This device is designed for WiMax, Wibro, WLAN, TD-SCDMA and other wireless infrastructure applications. It is also suited for 0.1 ~ 6 GHz applications with up to 100 watts of power.

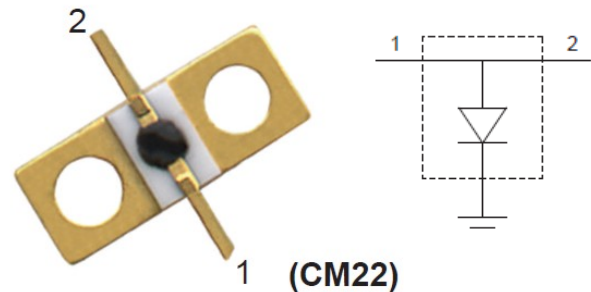

Electrical Specifications: $T_A = +25^\circ\text{C}$

Parameter	Test Conditions	Units	Min.	Typ.	Max.
Breakdown Voltage (V_B)	$I_R = 10 \mu\text{A}$	V	700	—	—
Forward Voltage (V_F)	$I_F = 100 \text{ mA}$	mV	—	850	—
Junction Capacitance (C_J)	$V_R = -50 \text{ V}$, 1 MHz	pF	—	0.4	—
Series Resistance (R_S)	$I_F = 100 \text{ mA}$, 500 MHz	Ω	—	0.4	0.6
I-Region (W)	I-Layer	μm	—	80	—
Insertion Loss (I_L)	$V_R = 50 \text{ V}$ 2.3 ~ 2.7 GHz <6.0 GHz	dB	—	0.15 0.35	0.25 0.45
Isolation (I_{SO})	$I_F = 100 \text{ mA}$ 2.3 ~ 2.7 GHz 6.0 GHz	dB	28 23	31 26	—
Input Return Loss (R_L)	$V_R = 50 \text{ V}$ 2.3 ~ 2.7 GHz 6.0 GHz	dB	15 10	22 15	—
Minority Carrier Lifetime (T_L)	$I_F = 10 \text{ mA}$, $I_R = 6 \text{ mA}$, @ 50%	ns	—	3400	—

Absolute Maximum Ratings

Parameter	Absolute Maximum
Peak Current	1 A
Thermal Resistance	5°C/W
Junction Temperature	$+175^\circ\text{C}$
Storage Temperature	-65°C to $+150^\circ\text{C}$
Solder Temperature	$+230^\circ\text{C}$ for 30 seconds

1 * Restrictions on Hazardous Substances, European Union Directive 2011/65/EU.

Typical RF Performance: Production Test Board
 $T_A = 25^\circ\text{C}$, $Z_0 = 50 \Omega$, -10 dBm Small Signal

Insertion Loss

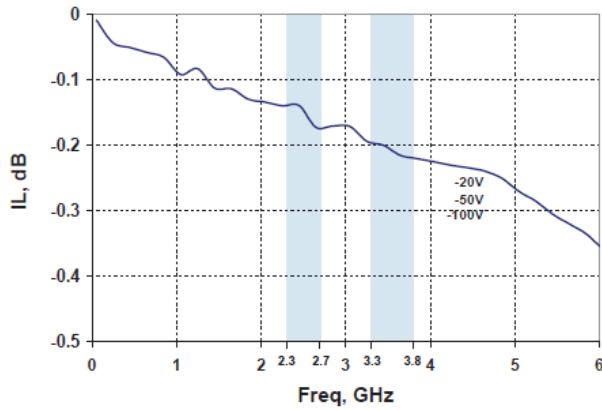

Isolation

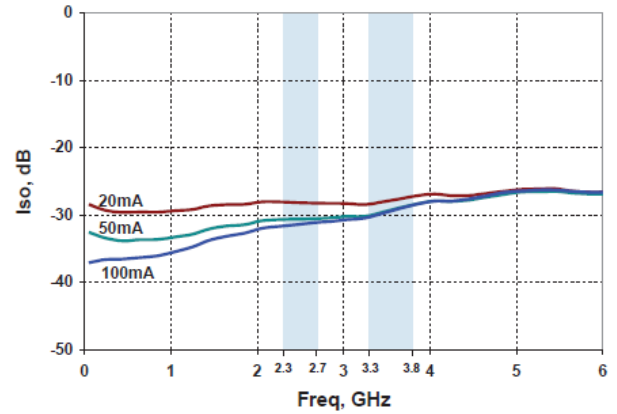

Input Return Loss

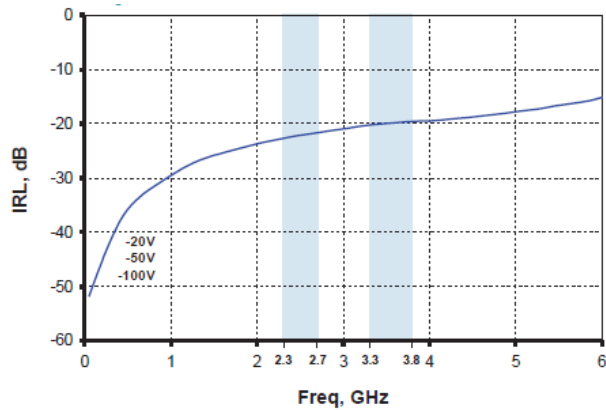

Series Resistance vs. Bias, 500 MHz

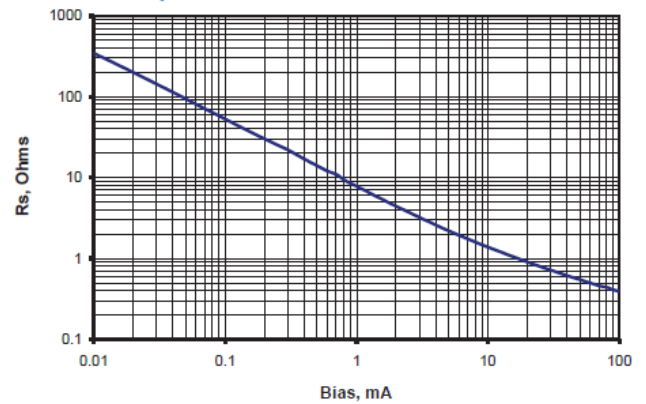

Typical RF Performance: Demo Board

$T_A = 25^\circ\text{C}$, $Z_O = 50 \Omega$, -10 dBm Small Signal, 100 mA Bias

Insertion Loss

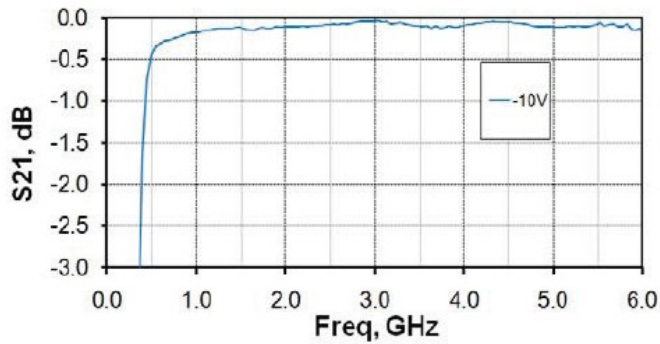

Isolation

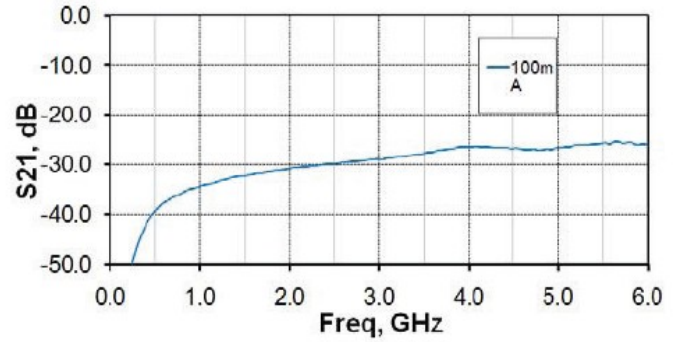

Input Return Loss

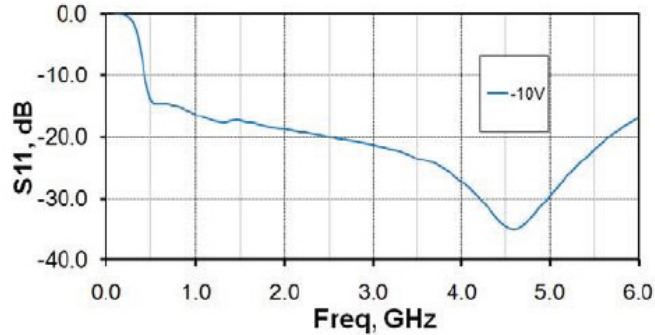

Output Return Loss

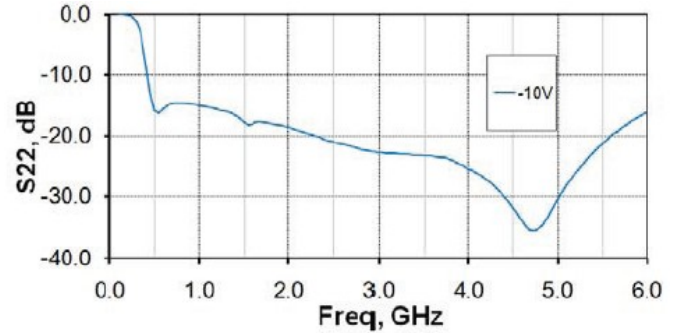

Recommended Demo PCB Layout

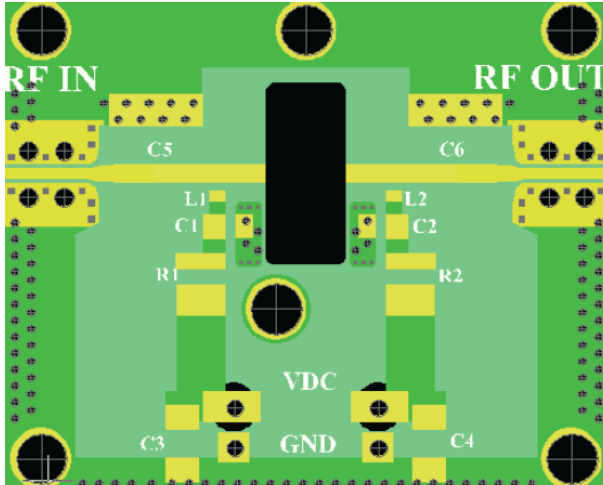

Dimensions: 1.50 in (3.81 cm) X 2.10 in (5.33cm)

Schematic

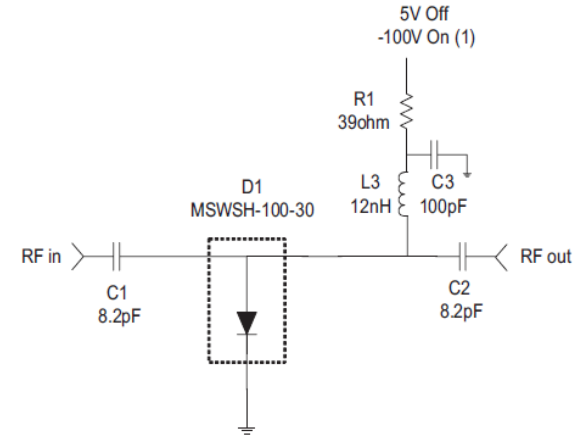

- notes:
(1) Different Input power require different reverse bias voltage

Electrical Specifications: $T_A = +25^\circ\text{C}$

Component	Value	Description	Manufacture	Manufacture Part #
C1, C2	8.2 pF	Capacitor, 0402 pkg, 20%	ATC	ATC600L8R2BT200T
C3	100 pF	Chip Capacitor, 0603 pkg, 20%	ATC	ATC600S101JT250XT
R1	39 Ω	Chip Resistor, 0.5 W, 5%	KOA Speer	RK73B3ATTD390J
L1	12 nF	Chip Inductor, 0402 pkg, 10%	ATC	ATC402WL120JT

Outline (2012)

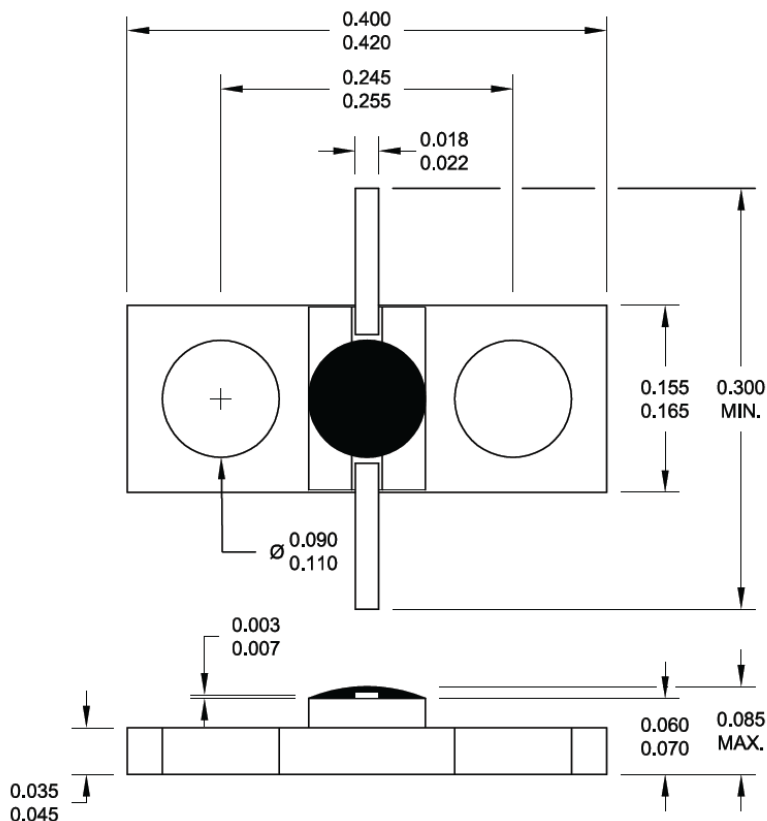

PIN FUNCTION

1,2 ANODE

Base Flange: CATHODE, RF and DC GROUND

(Inches)