

Enhanced Sensitivity Wavelength: 365nm

The MT03-022 is a 7.50mm² Active area Photodiode in a Isolated hermetic TO-5 metal can package. It is specifically designed for use @365nm or Blue/Green applications requiring high signal and low noise.

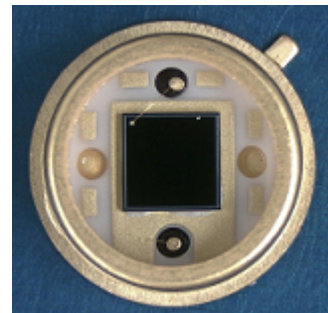

FEATURES

- > Ultra low noise
- > High Shunt Resistance
- > Wide Dynamic Range
- > 365nm and Blue/Green enhanced

APPLICATIONS

- > Color Meter
- > Currency Authentication
- > Spectroscopy Equipment
- > Fluorescence

Absolute Maximum Ratings



ITEMS	SYMBOL	RATINGS	UNIT
Reverse Voltage	VR	50	V
Operating Temperature Range	Topr	-40 ~ +100	°C
Storage Temperature Range	Tstg	-55 ~ +125	°C
Lead Soldering Temperature*1	Tls	260	°C

*1: Time 5 Sec max, Position: Up to 3mm from the body.

Electrical & Optical Characteristics (Ta = 23°C)

ITEMS	SYMBOL	CONDITIONS	MIN	TYP	MAX	UNIT
Dark Current	ID	Vr=5V	--	.1	10	nA
Forward Voltage	Vf	If=2mA	--	--	0.8	V
Breakdown Voltage	Vb	Ir=10uA	130	--	--	V
Spectral Sensitivity	λ	--	--	250-1100	--	nm
Peak Sensitivity Wavelength	λp	--	--	950	--	nm
Responsivity	Rt	Vr=0V, λ=365nm	0.18	0.22	--	A/W
Responsivity	Rt	Vr=0V, λ=633nm	--	0.38	--	A/W
Response Time 365nm	Tr	Vr=0V, RL=1kΩ	--	100	--	nS
Junction Capacitance	Cj	at 1MHz, Vr=0V	--	130	--	pF
Junction Capacitance	Cj	at 1MHz, Vr=5V	--	50	70	pF
Shunt Resistance	Rsh	Vr=10mV	--	400	--	mΩ

Device Dimensions

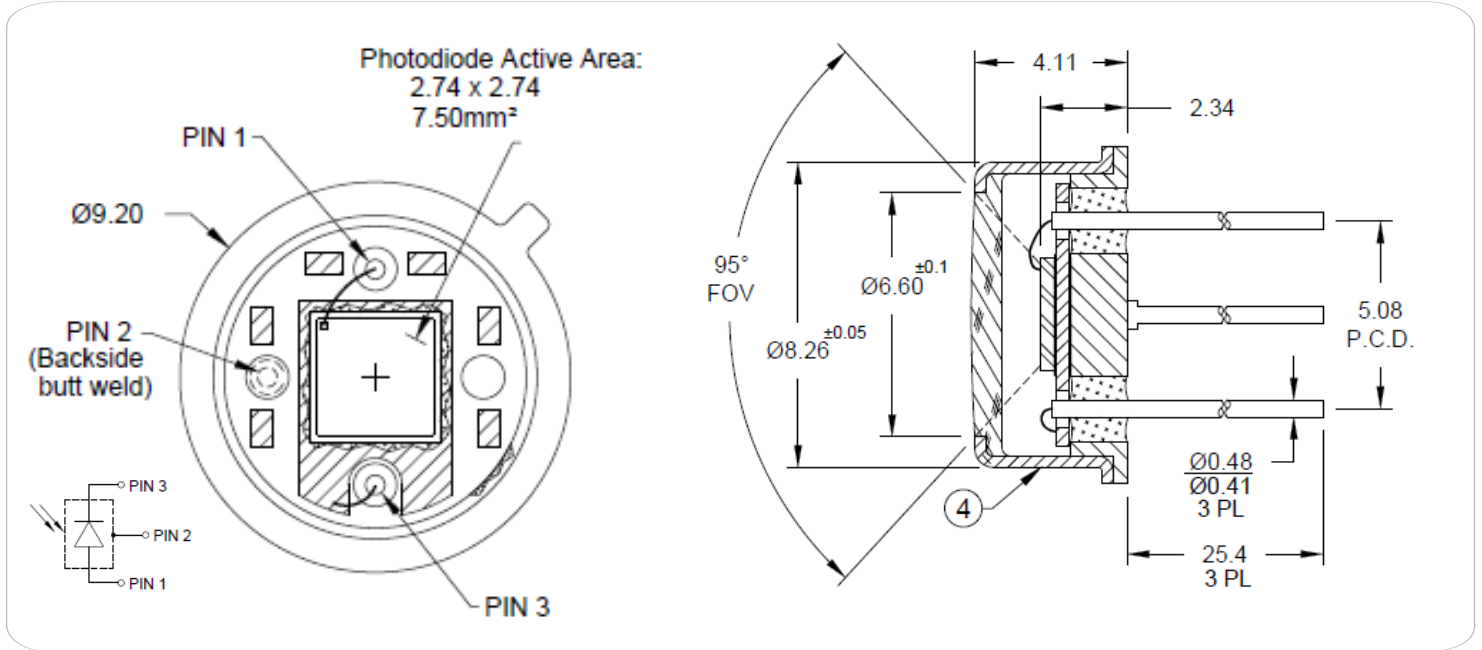

Marktech Photodiode Responsivity Series 4 [A/W]

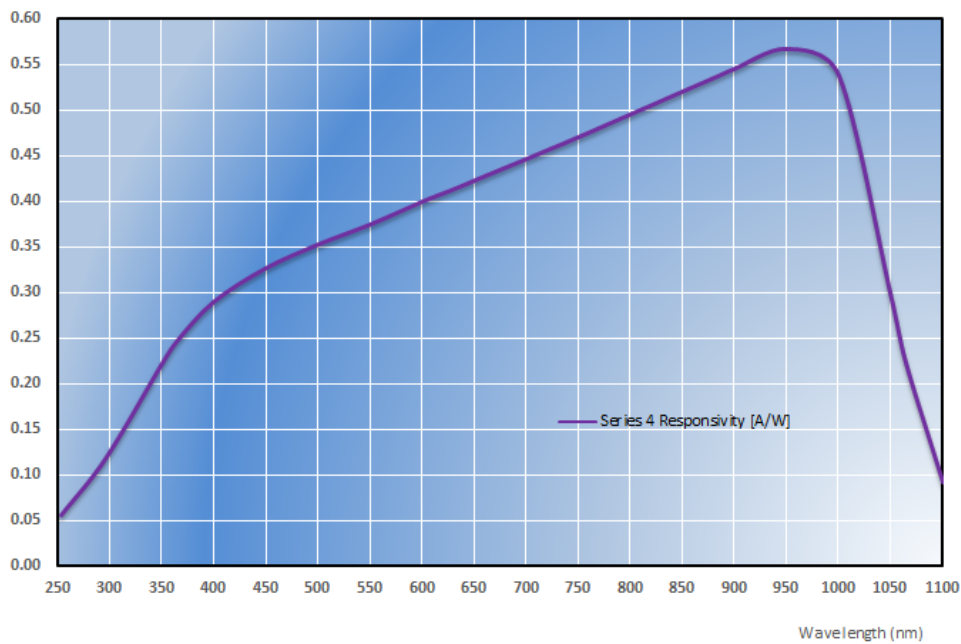

The information contained herein is subject to change without notice.

2017-06-28