



Micro Commercial Components
 130 W Cochran St, Unit B
 Simi Valley, CA 93065
 USA
 Tel:818-701-4933

MT200DT08L2
MT200DT12L2
MT200DT16L2
MT200DT18L2

Features

- Lead Free Finish/RoHS Compliant (NOTE 1)("P" Suffix designates RoHS Compliant. See ordering information)
- Blocking Voltage:800 to 1800V
- Three Phase Bridge and a Thyristor
- Low Forward Voltage

Applications

- Inverter for AC or DC motor control
- Current stabilized power supply
- Switching power supply
- UL recognized applied for file no.E360040

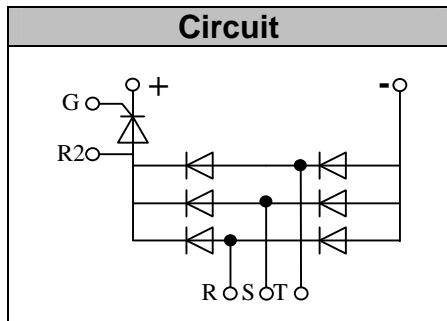
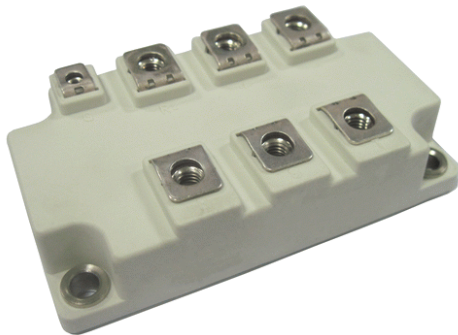

200 Amp
Three Phase
Bridge + Thyristor
800~1800 Volts

L2

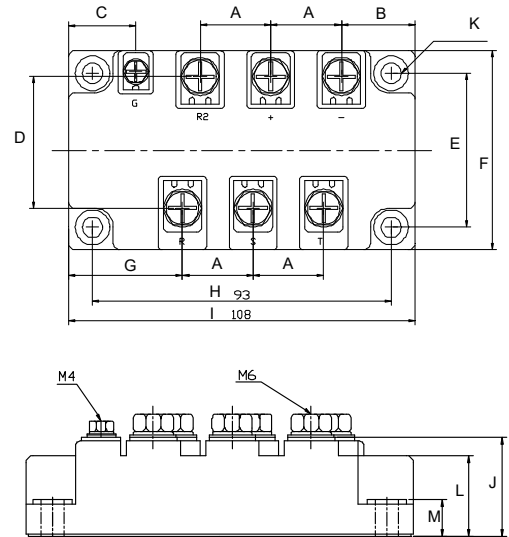

DIM	INCHES		MM		NOTE
	MIN	MAX	MIN	MAX	
A	0.854	0.878	21.50	22.50	
B	0.894	0.917	22.50	23.50	
C	0.815	0.839	20.50	21.50	
D	1.600	1.630	40.50	41.50	
E	1.880	1.900	47.50	48.50	
F	2.430	2.450	61.50	62.50	
G	1.390	1.410	35.00	36.00	
H	3.650	3.670	92.50	93.50	
I	4.240	4.260	107.50	108.50	
J	1.050	1.080	26.50	27.50	
K	0.256		6.50		∅
L	0.846	0.870	21.30	22.30	
M	0.323	0.346	8.00	9.00	

Module Type

TYPE	VRRM/ VDRM	VRSM
MT200DT08L2	800V	900V
MT200DT12L2	1200V	1300V
MT200DT16L2	1600V	1700V
MT200DT18L2	1800V	1900V

◆Diode

Maximum Ratings

Symbol	Item	Conditions	Values	Units
Id	Output Current(D.C.)	Tc=96°C Three phase full wave	200	A
IFSM	Surge forward current	t=10mS Tvj =45°C	1900	A
i ² t	Circuit Fusing Consideration		18050	A ² s
Visol	Isolation Breakdown Voltage(R.M.S)	a.c.50HZ;r.m.s.;1min	3000	V
Tvj	Operating Junction Temperature		-40 to +150	°C
Tstg	Storage Temperature		-40 to +125	°C
Mt	Mounting Torque	To terminals(M4)	2±15%	Nm
Mt		To terminals(M6)	5±15%	Nm
Ms		To heatsink(M6)	5±15%	Nm
Weight		Module (Approximately)	320	g

Thermal Characteristics

Symbol	Item	Conditions	Values	Units
Rth(j-c)	Thermal Impedance, max.	Junction to Case(TOTAL)	0.12	°C/W
Rth(c-s)	Thermal Impedance, max.	Case to Heat sink	0.06	°C/W

Electrical Characteristics

Symbol	Item	Conditions	Values	Units
VFM	Forward Voltage Drop, max.	T=25°C IF =200A	1.35	V
I _{RRM}	Repetitive Peak Reverse Current, max.	Tvj =25°C VRD=VRRM Tvj =150°C VRD=VRRM	≤2 ≤10	mA mA

◆ Thyristor Maximum Ratings

Symbol	Item	Conditions	Values	Units
I_{TAV}	Average On-State Current	$T_C=93^{\circ}\text{C}$, Single Phase half wave 180° conduction	200	A
I_{TSM}	Surge On-State Current	$T_{VJ}=45^{\circ}\text{C}$ $t=10\text{ms}$ (50Hz), sine $V_R=0$	1900	A
i^2t	Circuit Fusing Consideration		18050	A^2s
Visol	Isolation Breakdown Voltage(R.M.S)	a.c.50HZ;r.m.s.;1 min	3000	V
T_{vj}	Operating Junction Temperature		-40 to +125	$^{\circ}\text{C}$
T_{stg}	Storage Temperature		-40 to +125	$^{\circ}\text{C}$
M_t	Mounting Torque	To terminals(M4)	$2\pm 15\%$	Nm
M_t		To terminals(M6)	$5\pm 15\%$	
M_s		To heatsink(M6)	$5\pm 15\%$	Nm
di/dt	Critical Rate of Rise of On-State Current	$T_{VJ}=T_{VJM}$, $V_D=1/2V_{DRM}$, $I_G=100\text{mA}$ $d_iG/d_t=0.1\text{A}/\mu\text{s}$	200	$\text{A}/\mu\text{s}$
dv/dt	Critical Rate of Rise of Off-State Voltage, min.	$T_J=T_{VJM}$, $V_D=2/3V_{DRM}$, linear voltage rise	500	$\text{V}/\mu\text{s}$

Electrical and Thermal Characteristics

Symbol	Item	Conditions	Values			Units
V_{TM}	Peak On-State Voltage, max.	$T=25^{\circ}\text{C}$ $I_T=200\text{A}$			1.40	V
I_{RRM}/I_{DRM}	Repetitive Peak Reverse Current, max. / Repetitive Peak Off-State Current, max.	$T_{VJ}=T_{VJM}$, $V_R=V_{RRM}$, $V_D=V_{DRM}$			100	mA
V_{GT}	Gate Trigger Voltage, max.	$T_{VJ}=25^{\circ}\text{C}$, $V_D=6\text{V}$			3	V
I_{GT}	Gate Trigger Current, max.	$T_{VJ}=25^{\circ}\text{C}$, $V_D=6\text{V}$			150	mA
$R_{th(j-c)}$	Thermal Impedance, max.	Junction to Case			0.14	$^{\circ}\text{C}/\text{W}$
$R_{th(c-s)}$	Thermal Impedance, max.	Case to Heatsink			0.06	$^{\circ}\text{C}/\text{W}$

Performance Curves

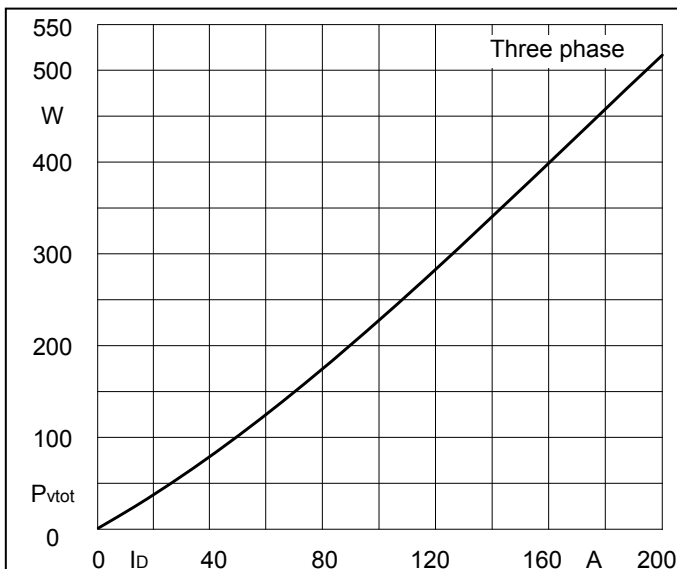

Fig1. Power dissipation

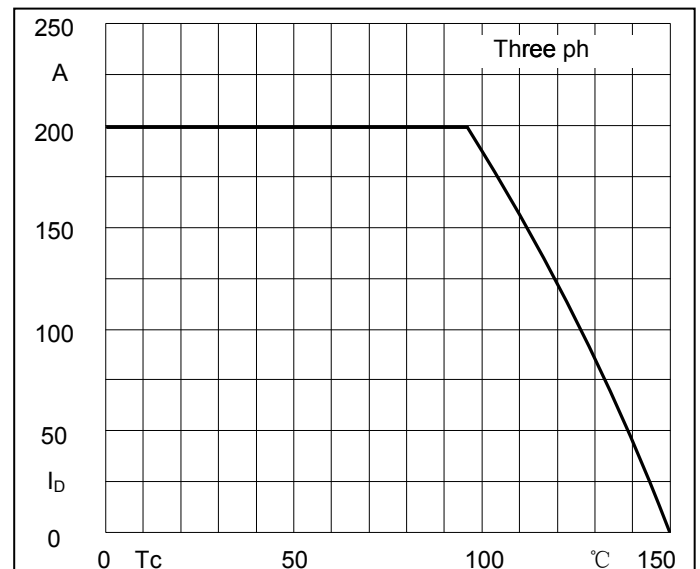

Fig2. Forward Current Derating Curve

Performance Curves

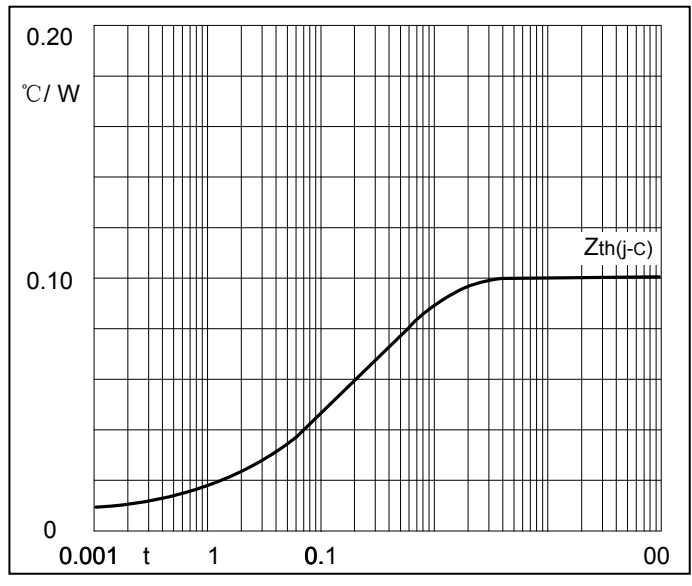

Fig3. Transient thermal impedance

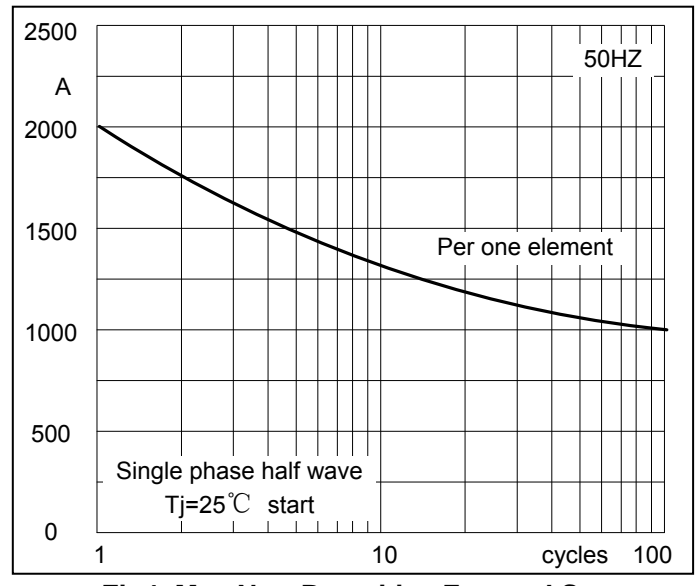

Fig4. Max Non-Repetitive Forward Surge Current

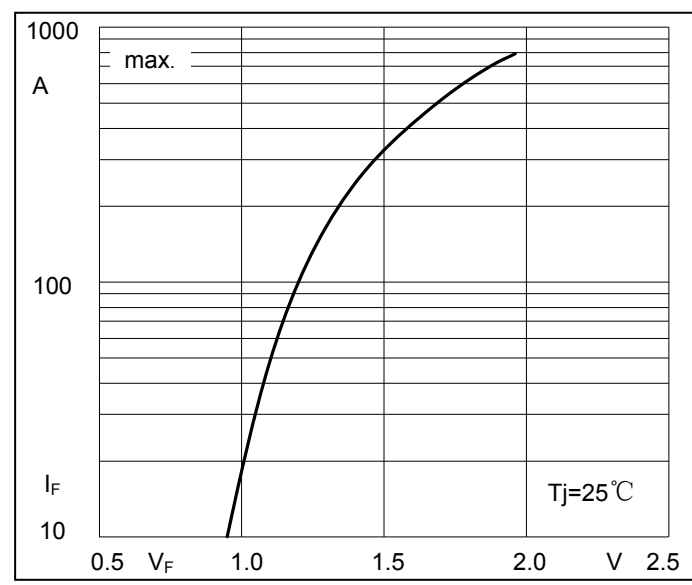

Fig5. Forward Characteristics

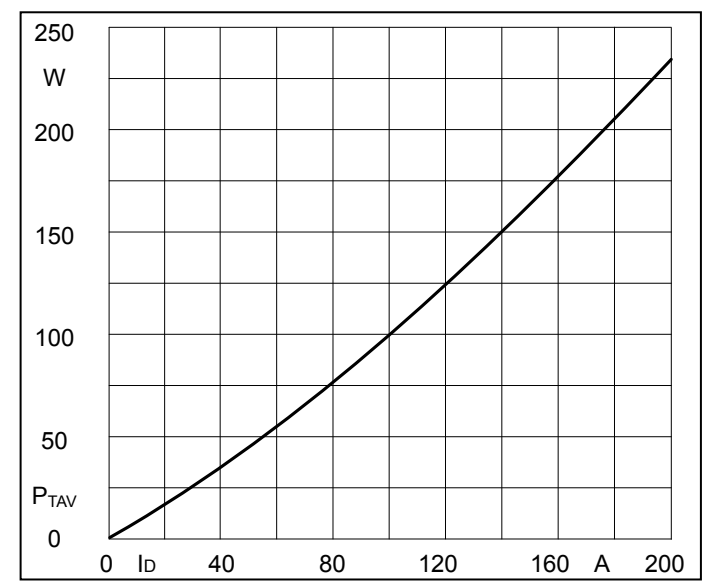

Fig6. SCR Power dissipation

Performance Curves

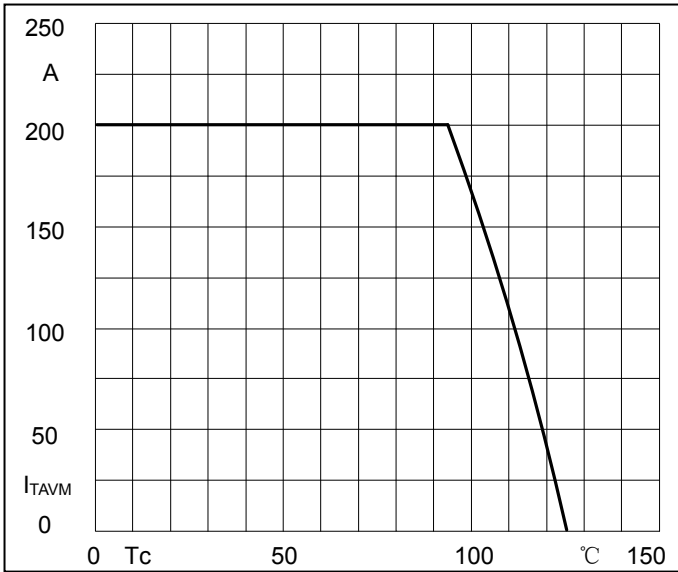

Fig7. SCR Forward Current Derating Curve

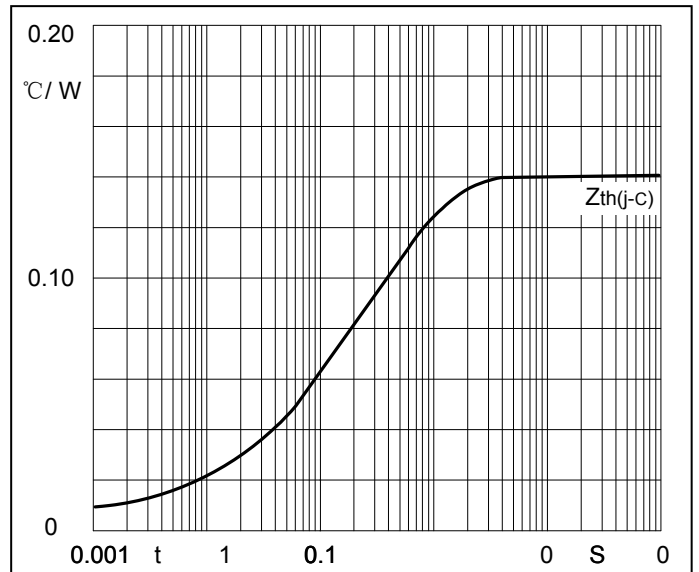

Fig8. SCR Transient thermal impedance

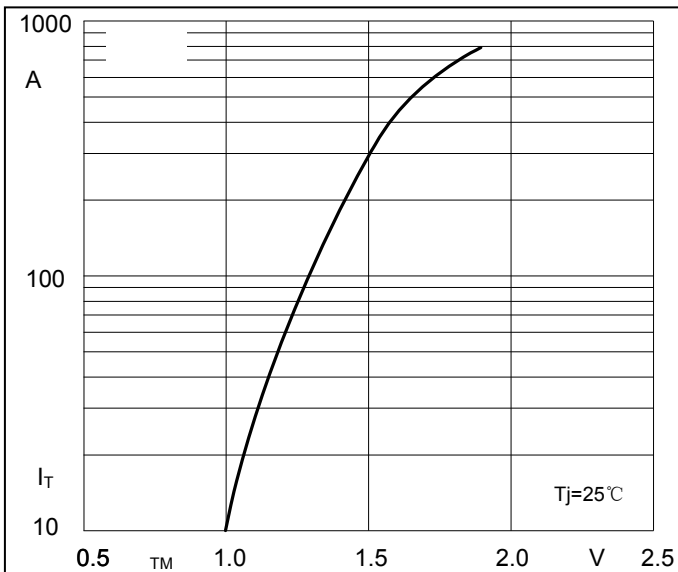

Fig9. SCR Forward Characteristics

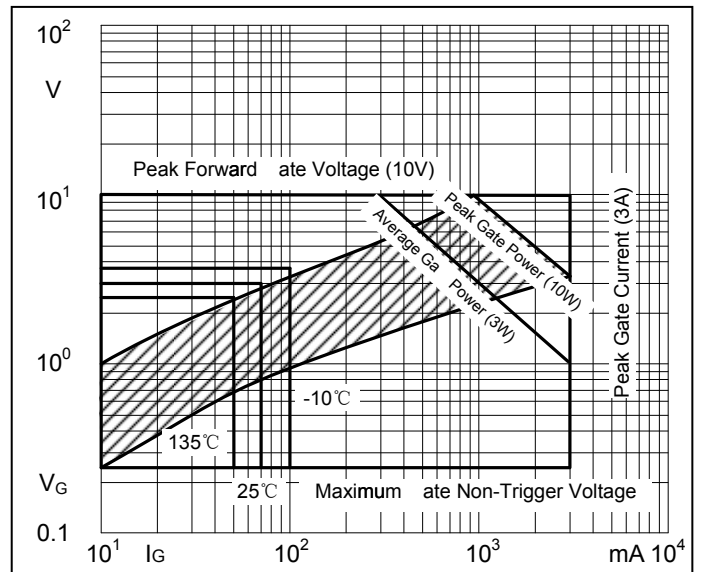

Fig10. Gate trigger Characteristics