

REVISIONS			
LTR	DESCRIPTION	DATE	APPROVED
C	REVISED PER ECN ## T-5208	5-6-85	JBS

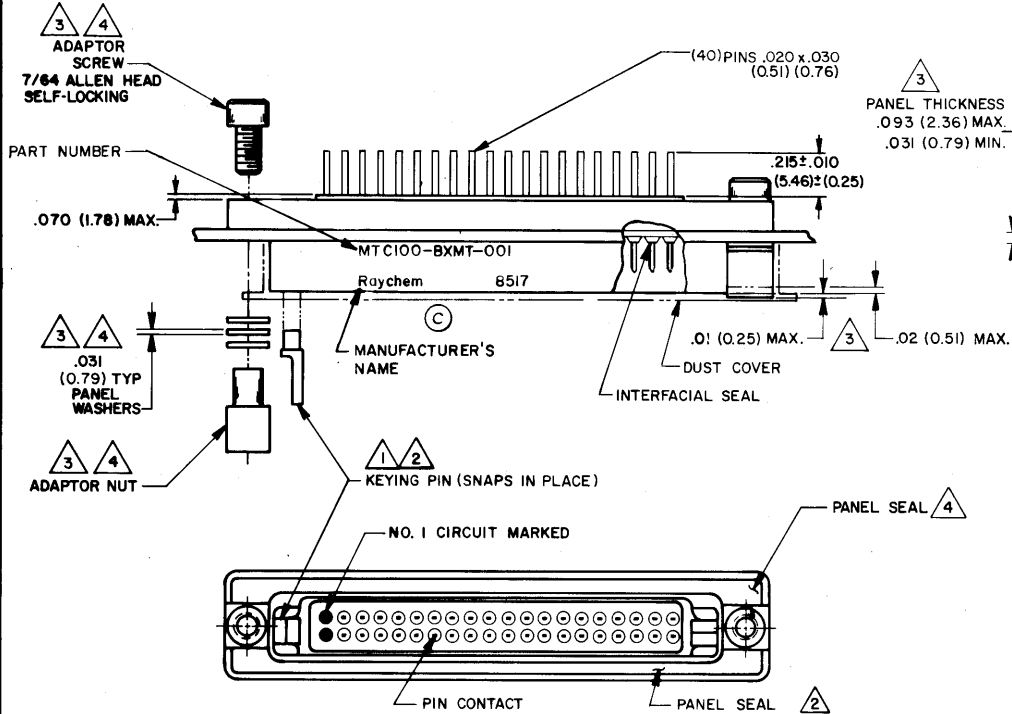

3  
PANEL THICKNESS  
.093 (2.36) MAX.  
.031 (0.79) MIN.

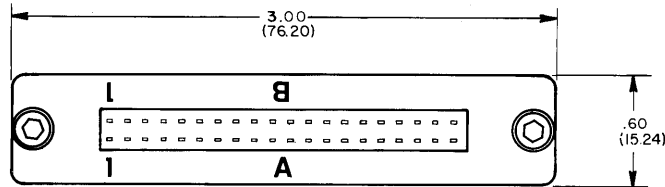
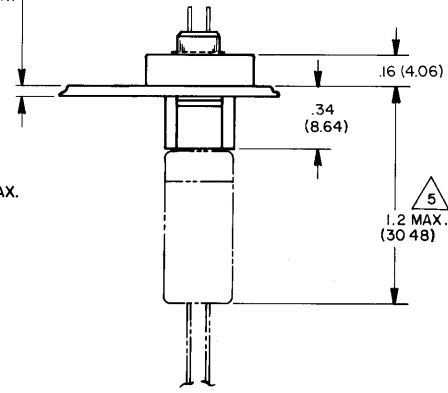

RECOMMENDED PANEL CUT-OUT

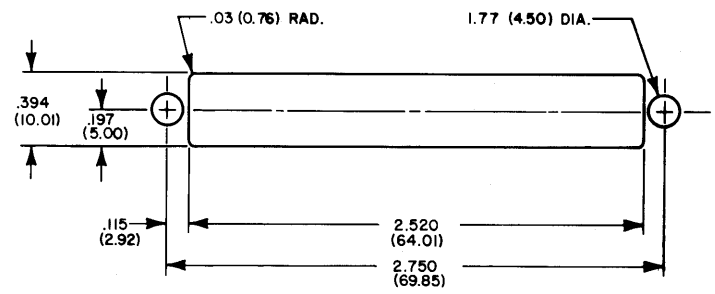

- NOTES:
- 1 BOX MOUNTED RECEPTACLE MATES WITH MTC PLUG MTC100-JH2-PXX CONTAINING SOCKET WAFERS MTC100-JXX-XXX. REFER TO RAYCHEM SPECIFICATION CONTROL DRAWING FOR DETAILS.
  - 2 FOR KEYING INFORMATION, SEE SHEET 2, TABLE I.
  - 3 BOX MOUNTED RECEPTACLE IS PANEL MOUNTED BY REMOVING AS MANY PANEL WASHERS AS REQUIRED TO ACCOMMODATE THE THICKNESS OF PANEL BEING USED. USE ONLY ADAPTOR SCREWS SUPPLIED. ADAPTOR NUT TO BE FLUSH WITH FRONT OF PART WITHIN TOLERANCE INDICATED.
  - 4 THE FOLLOWING ITEMS ARE SUPPLIED UNASSEMBLED:  
ADAPTOR NUT (2)  
PANEL WASHER (6)  
ADAPTOR SCREW (2)  
KEYING PIN (2)  
PANEL SEAL (1)
  - 5 DIMENSIONS SHOWN ARE FOR PLUG WITHOUT THE CABLE CLAMP. ADD .30 IF PLUG WITH CABLE CLAMP IS USED.

© Raychem Corporation 1980

DRAWN	JAMAL	3-18-80	Raychem	
CHECKED			SPECIFICATION CONTROL DRAWING	
APPROVED	<i>[Signature]</i>	3-25-80	TITLE	
APPROVED	<i>[Signature]</i>	4-7-80	RECEPTACLE - BOX MOUNT	
APPROVED			MTC100 - SHORT TAIL	
UNLESS OTHERWISE SPECIFIED DIMENSIONS ARE IN INCHES AND TOLERANCES ARE: XXX ± .005 (0.13) XX ± .02 (0.51) — ± —			SIZE	CODE IDENT.
			C	NO. 06090
			DWG. NO. MTC 100-BXMT-001	
DO NOT SCALE THIS DRAWING				SHEET 1 OF 2

If this document is printed it becomes uncontrolled.  
Check with the web for latest revision.

**SPECIFICATION**

REFER TO RAYCHEM SPECIFICATION D6012 FOR DETAILED PERFORMANCE REQUIREMENTS AND TEST PROCEDURES. REQUIREMENTS AND PROCEDURES ARE IDENTICAL TO THOSE FOR 6012 CONNECTORS UNLESS OTHERWISE SPECIFIED HEREIN.

**MATERIALS:**

- A. HOUSING SHELL ALUMINUM ALLOY PER QQ-A-591
- B. ADAPTOR SCREW STAINLESS STEEL PER QQ-S-763, 300 SERIES
- C. ADAPTOR NUT STAINLESS STEEL PER QQ-S-763, 300 SERIES
- D. PANEL WASHER STAINLESS STEEL PER QQ-S-763, 300 SERIES
- E. DIELECTRIC INSERT INSERT MATERIAL HIGH GRADE POLYARYLENE THERMOPLASTIC
- F. FACE SEAL AND PANEL SEAL SILICONE ELASTOMER PER ZZ-R-765
- G. KEYING PIN POLYARYLENE THERMOPLASTIC, MOLDED
- H. PIN CONTACT COPPER ALLOY PER QQ-B-750

**FINISH:**

- A. HOUSING SHELL NICKEL PLATE
- B. ADAPTOR SCREW PASSIVATED PER QQ-P-35
- C. ADAPTOR NUT PASSIVATED PER QQ-P-35
- D. PANEL WASHER PASSIVATED PER QQ-P-35
- E. PIN CONTACT FINISH ON MATING END: GOLD PLATED PER MIL-C-45204 TYPE I, GRADE C, CLASS I.  
FINISH ON TERMINATION END: SUITABLE FOR Sn63 SOLDER TERMINATION.

**DESIGN AND CONSTRUCTION: (REF PARA 3.5)**

THE CONNECTORS SPECIFIED HEREIN ARE PANEL MOUNTED RECEPTACLES WITH FIXED (NON REMOVABLE) PIN INSERTS AND CONTACTS. THE CONTACTS ARE SOLDER TAILS WITHOUT PROVISIONS FOR CABLE CLAMPS OR TERMINATION SEALS.

**PERFORMANCE: (REF PARA 3.6)**

PERFORMANCE SHALL BE IN ACCORDANCE WITH D6012 EXCEPT AS FOLLOWS:

HUMIDITY	PARA 3-6-17
ALTITUDE IMMERSION	PARA 3-6-18
ALTITUDE-LOW TEMPERATURE	PARA 3-6-19
FLUID IMMERSION	PARA 3-6-23

SOLDER TAILS MUST BE SUITABLY PROTECTED FROM THE ENVIRONMENT.

**RATING:**

TEMPERATURE	-65° C +125° C
VOLTAGE (AC)	375 V
CURRENT	5 A

**WEIGHT:**

.056 LBS

REV.	DATE	APPROVED
SEE SHEET ONE		

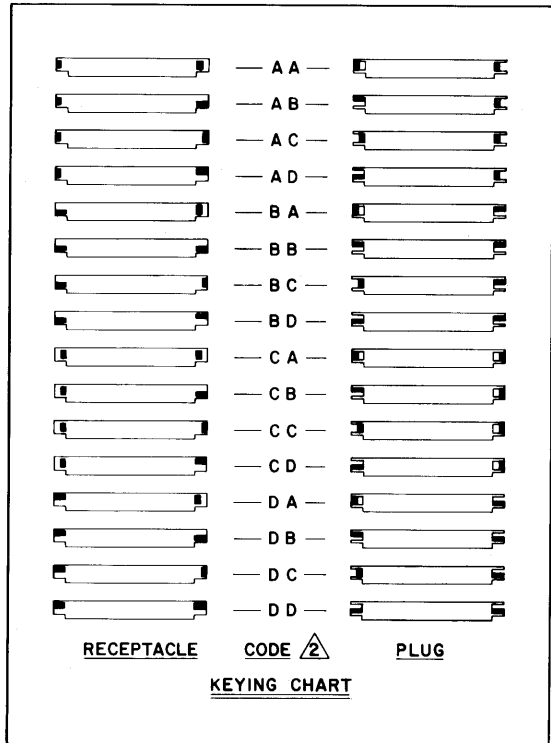

**NOTES:**

- I. TWO KEYING PINS ARE SUPPLIED, NOT INSTALLED, WITH EACH RECEPTACLE. USER TO PRESS INTO PROPER KEYING POSITION (SEE TABLE I)
- △ KEYING POSITION CODE DOES NOT FORM A PART OF THE RAYCHEM PART NUMBER AND SHOULD BE OMITTED WHEN ORDERING.

**SPECIFICATION CONTROL DRAWING**

© Raychem Corporation 1980

UNLESS OTHERWISE SPECIFIED DIMENSIONS ARE IN INCHES BRACKETED DIMENSIONS ( ) ARE METRIC AND TOLERANCES ARE:  .XXX: ± ( ) .XX: ± ( ) △: ±	DRAWN	JAMAL	3/24/80	<b>Raychem</b> <small>RAYCHEM CORPORATION 300 CONSTITUTION DRIVE MENLO PARK, CALIFORNIA 94025</small>
	CHECKED			
	APPROVED	<i>[Signature]</i>		
	APPROVED	<i>[Signature]</i>		
				TITLE
				RECEPTACLE-BOX MOUNT MTC100-SHORT TAIL
		SIZE	CODE IDENT	DWG. NO.
		C	NO. 06090	MTC 100-BXMT-001
			WEIGHT	SHEET 2 OF 2

If this document is printed it becomes uncontrolled.  
Check with the web for latest revision.

DO NOT SCALE THIS DRAWING