

**Industrial PCs applied in**

- ✓ Logistics and Warehouse
- ✓ Heavy Duty
- ✓ Fleet Management
- ✓ Stationary and Automation



**MTC 6 Series  
Manual V3.10**

This manual contains a detailed description of the product and we have made every effort to make it as accurate as possible. However, this is not a guarantee of the features or the functionality of the product.

We reserve the right to modify the contents of this document at any time and without prior notice.

Because we at Advantech-DLoG are constantly striving to improve this product, we cannot guarantee that previous or subsequent releases of the product will correspond in every respect with the product description given in this manual.

Advantech-DLoG assumes no liability for technical inaccuracies, typographic errors or faults in this documentation.

Advantech-DLoG also assumes no liability for damages caused directly or indirectly by the delivery, performance or usage of this material.

The software and hardware designations used in this documentation are in most cases also registered trademarks and are thus subject to law. Windows® is a registered trademark of Microsoft Corporation in the United States (US) and other countries.

This documentation is protected by copyright. Duplication, in whole or in part, is not permitted without prior written approval of Advantech-DLoG!

Title of documentation:	MTC 6 Series User's Manual
Documentation completed on:	September 25th 2013
Version:	V3.10
Product number	885253E03

© Copyright 2010 - 2013

DLoG GmbH  
Industriestraße 15  
D-82110 Germering  
Germany

All rights reserved

#### Technical customer support

If you experience technical difficulties, please consult your distributor or contact the technical services department at Advantech-DLoG's headquarters:

(+49) 89 / 41 11 91 0

[www.advantech-dlog.com](http://www.advantech-dlog.com)

## Konformitätserklärung/ Declaration of Conformity

... gemäß den Bestimmungen der EG-Richtlinie über elektromagnetische Verträglichkeit 2004/108/EG und der EG-Richtlinie über Niederspannung 2006/95/EG, sowie der RTTE EG-Richtlinie 1999/5/EG, falls Datenübertragungsgeräte, die im 2,4GHz Band arbeiten, von DLoG installiert wurden.

... in accordance with the EU-Directive of Electromagnetic-Compatibility 2004/108/EC of the council and the EU-Directive for Low Voltage 2006/95/EC of the council, as well as the EU-Directive for radio equipment 1999/5/EC in case of data transmission equipment operating in the 2,4GHz band is assembled by DLoG.

Jahr, in dem das CE Zeichen für das Produkt erstmals vergeben wurde/ Year CE marking was first affixed to declared product:  
**2010**

Die Firma / The Manufacturer

**DLoG Gesellschaft für elektronische Datentechnik mbH, Industriestr. 15, D-82110 Germering, Germany**  
erklärt hiermit, dass das Produkt / declares, that the product described in the following

Geräteart/Designation of device:	Gerätetyp/Type of device:
<b>Industrie-PC/Industrial PC</b>	<b>MTC 6</b>

mit den oben genannten / folgenden Normen oder normativen Dokumenten übereinstimmt /  
is conform to the aforementioned / following standards or normative documents.

### EMC-Störaussendung (EMC-Emission) / EMC-Störfestigkeit (EMC-Immunity):

2004/108/EG EN 55022:2006+A1:2007 Class A	Information technology equipment – radio disturbance characteristics – limits and methods of measurement
EN 55024:1998 + A1:2001 + A2:2003	Information technology equipment – immunity characteristics – limits and methods of measurement
EN 61000-3-2:2006 + A1:2009 + A2:2009	Electromagnetic compatibility (EMC) – limits for harmonic current emissions (equipment input current <= 16 A per phase) – For AC only
EN 61000-3-3:2008	Electromagnetic compatibility (EMC) - Part 3-3: Limits - Limitation of voltage changes, voltage fluctuations and flicker in public low-voltage supply systems, for equipment with rated current <= 16 A per phase and not subject to conditional connection For AC only
EN 61000-6-2:2005	Electromagnetic compatibility (EMC) - Part 6-2: Generic standards - Immunity for industrial environments
EN 300 328 V1.7.1	Data transmission equipment operating in the 2,4GHz ISM band and using wide band modulation techniques
EN 301 489-17 V2.1.1	Specific conditions for 2,4GHz wideband transmission systems and 5GHz high performance WLAN equipment
EN 301 489-1 V1.8.1	Electromagnetic compatibility and Radio spectrum Matters (ERM); Electro Magnetic Compatibility (EMC) standard for radio equipment and services; Part 1: Common technical requirements

### Sicherheit (Safety):

2006/95/EG EN 60950-1:2006+A11:2009	Information technology equipment - Safety - Part 1: General requirements
--	--

Germering, 02.08.12

Ort, Datum/Place, Date

  
 Gesellschaft für elektronische  
 Datentechnik mbH  
 Industriestrasse 15 · D-82110 Germering  
 Tel.: +49 (0) 89 / 4 111 91-0  
 Thorsten Kraus – Executive Director  
 Technology Center & Operations

DofC



# Content

<b>1.</b>	<b>About this manual</b>	<b>1</b>
1.1.	For qualified personnel	1
1.2.	Please read documentation accompanying the product	1
1.3.	Current manuals and drivers on the internet	1
1.4.	Keep this manual	1
1.5.	Design method	2
1.6.	Trademarks	2
<b>2.</b>	<b>Basic safety guidelines</b>	<b>3</b>
2.1.	Always install, operate, and maintain the unit properly	3
2.2.	Safety	3
2.3.	Intended usage	3
2.4.	Preventing electrical hazards	4
2.5.	When mounting please note the following	5
2.6.	Connect / disconnect external devices	6
2.7.	Transmission of radio frequencies	6
2.8.	Clean / maintain industrial PC	7
2.9.	Modifications and repairs only by Advantech-DLoG	7
2.10.	CE Marking	7
2.11.	RTTE Directive 1999/5/EC	8
2.11.1.	Special rule/restriction	9
2.12.	FCC user information	9
<b>3.</b>	<b>Device description – Technical specifications</b>	<b>10</b>
3.1.	Device models	10
3.2.	Abbreviations used for devices and accessories	10
3.3.	Device/type identification	11
3.4.	Technical specifications	12
3.4.1.	MTC 6 Intel: CPU, Cache, RAM	12
3.4.2.	MTC 6 AMD: APU, Cache, RAM	12
3.4.3.	Housing - Mechanical	13
3.4.4.	MTC 6 Intel: Display	13
3.4.5.	MTC 6 AMD: Display	13
3.4.6.	Operating systems (optional) for MTC 6 Intel	14
3.4.7.	Operating systems (optional) for MTC 6 AMD	14
3.4.8.	Serial port	14
3.4.9.	USB, Service USB	14
3.4.10.	MTC 6 Intel: LCD interface	15
3.4.11.	MTC 6 AMD: LCD interface	15
3.4.12.	Touch interface	15
3.4.13.	MTC 6 Intel: Network interface	15
3.4.14.	MTC 6 AMD: Network interface	15
3.4.15.	Integrated speaker/sound	16
3.4.16.	Voice Kit (optional)	16
3.4.17.	Integrated WLAN antenna (optional)	17
3.4.18.	Remote WLAN antenna ( optional)	17
3.4.19.	Power supply	18
3.4.20.	Power supply fuses	19
3.4.21.	Ambient conditions	20
3.5.	Dimensions	21
3.5.1.	MTC 6/10	21
3.5.2.	MTC 6/12	24
3.5.3.	MTC 6/15	27
3.6.	VESA drill holes	30
3.6.1.	MTC 6/10	30
3.6.2.	MTC 6/12	31
3.6.3.	MTC 6/15	32

<b>4.</b>	<b>Unpacking the device .....</b>	<b>33</b>
4.1.	Scope of delivery.....	33
4.2.	Packaging .....	33
4.3.	Returning your device .....	33
<b>5.</b>	<b>Initial operation .....</b>	<b>34</b>
5.1.	MTC 6 with Linux operating system.....	34
5.2.	MTC 6 with MS Windows operating system .....	34
5.3.	Images for Intel and AMD devices are not compatible .....	34
5.4.	Pre-installed on Flash .....	34
5.5.	Installing on Flash .....	35
5.6.	DLoG Config: Front keys, automatic switch-off .....	35
5.7.	WLAN settings .....	36
5.7.1.	Radio performance.....	36
5.7.2.	Antenna solutions for use in Germany .....	37
5.7.3.	Summit Client Utility for WLAN configuration.....	38
5.8.	Calibrate / re-calibrate the touch screen .....	40
5.9.	Protecting the TFT display from the memory effect.....	40
5.10.	Removing the protective film from the display .....	40
5.11.	External connectors .....	41
5.11.1.	DC voltage supply connector.....	41
5.11.2.	Power supply cables.....	42
5.11.3.	MTC 6 power supply cable .....	42
5.12.	Service USB interface .....	43
5.13.	Connecting external devices .....	44
5.14.	Powering up the MTC 6 .....	44
<b>6.</b>	<b>Accessories (Options).....</b>	<b>45</b>
6.1.	Keyboard.....	45
6.2.	Mouse .....	45
6.3.	Microphone (Voice Kit).....	45
6.4.	External CD/DVD-ROM drive.....	46
6.5.	USB stick.....	46
6.6.	USB recovery stick.....	46
6.7.	Scanners .....	46
6.7.1.	Scanner bracket .....	46
6.8.	WLAN card (PCIe MiniCard).....	46
<b>7.</b>	<b>Mounting.....</b>	<b>47</b>
7.1.	Pay careful attention to mounting instructions .....	47
7.2.	Cooling through the supply of fresh air .....	47
7.3.	Power supply.....	47
7.4.	Vehicle applications (such as forklifts) .....	49
7.4.1.	Position of the MTC 6 in the vehicle.....	49
7.5.	Cable cover (splash guard).....	50
7.6.	Strain relief .....	50
7.7.	Minimum distance to WLAN antenna.....	51
7.8.	Antenna cap and service USB interface .....	51
<b>8.</b>	<b>Operation.....</b>	<b>53</b>
8.1.	Touch Screen.....	53
8.2.	Software Keyboard.....	53
8.3.	Front keys and LEDs.....	54
8.3.1.	<Power> key and brightness control.....	54
8.3.2.	LEDs .....	54
8.3.3.	Special keys.....	55
8.3.4.	<Shift>-key.....	55
8.4.	Operating states.....	55

<b>9.</b>	<b>Touch screen</b> .....	<b>56</b>
9.1.	Construction type and resistance .....	56
9.2.	Operation.....	56
9.3.	Cleaning .....	56
9.4.	Calibrating the Touch screen .....	56
	Calibrating with UPDD .....	57
	Calibrating with TSHARC.....	58
<b>10.</b>	<b>Serial port</b> .....	<b>59</b>
10.1.	COM1 as a power supply (optional).....	59
10.2.	Serial port printers.....	59
10.3.	Serial port barcode scanners .....	59
10.4.	Tips & tricks.....	59
<b>11.</b>	<b>Internal devices</b> .....	<b>60</b>
11.1.	Network adapter (10/100/1000) .....	60
	11.1.1. MTC 6 Intel.....	60
	11.1.2. MTC 6 AMD.....	60
	11.1.3. Problems with data transmission via LAN/Ethernet.....	60
11.2.	Automatic switch-off.....	61
	11.2.1. Automatic switch-off process .....	61
	11.2.2. Configuration with DLoG Config program.....	62
<b>12.</b>	<b>Troubleshooting</b> .....	<b>63</b>
12.1.	Data transmission via LAN/Ethernet.....	63
12.2.	Images for Intel and AMD devices are not compatible .....	63
12.3.	MTC 6/12 AMD: switch off / restart .....	63
<b>13.</b>	<b>Maintenance</b> .....	<b>64</b>
13.1.	Cleaning the housing .....	64
13.2.	Touch screen cleaning.....	64
<b>14.</b>	<b>Common mistakes in usage</b> .....	<b>65</b>
14.1.	Images for Intel and AMD devices are incompatible.....	65
14.2.	Power supply.....	65
14.3.	Powering up/down.....	65
14.4.	Cable cover .....	65
14.5.	Mounting/Installation .....	65
14.6.	Mobile application on vehicles .....	66
14.7.	Using the touch screen .....	66
<b>15.</b>	<b>Disposal</b> .....	<b>66</b>
<b>16.</b>	<b>Return packing slip</b> .....	<b>67</b>
	<b>Index</b> .....	<b>68</b>

# List of figures

Figure 3.1: 15" model MTC 6 series .....	10
Figure 3.2: Speaker (MTC 6 back) .....	16
Figure 3.3: Voice Kit handset microphone (optional).....	16
Figure 3.4: Integrated antenna .....	17
Figure 3.5: Remote antenna.....	17
Figure 3.6: Dimensions MTC 6/10 front view .....	21
Figure 3.7: Dimensions MTC 6/10 side view .....	22
Figure 3.8: Dimensions MTC 6/10 top view.....	23
Figure 3.9: Dimensions MTC 6/12 front view .....	24
Figure 3.10: Dimensions MTC 6/12 side view .....	25
Figure 3.11: Dimensions MTC 6/12 top view.....	26
Figure 3.12: Dimensions MTC 6/15 front view .....	27
Figure 3.13: Dimensions MTC 6/15 side view .....	28
Figure 3.14: Dimensions MTC 6/15 top view.....	29
Figure 3.15: Position of the VESA drill holes MTC 6/10 .....	30
Figure 3.16: Position of the VESA drill holes MTC 6/12 .....	31
Figure 3.17: Position of the VESA drill holes MTC 6/15 .....	32
Figure 5.1: DLoG Config Program Menu.....	35
Figure 5.2: Configuring the antenna transmitting power with SCU (example).....	37
Figure 5.3: Summit Client Utility Icon .....	38
Figure 5.4: Wi-Fi Icon in Control Panel.....	38
Figure 5.5: Summit Client Utility menu .....	39
Figure 5.6: Summit Client Utility password input .....	39
Figure 5.7: External connectors with optional ext. antenna .....	41
Figure 5.8: External connectors detail view (with ext. antenna) .....	41
Figure 5.9: Exterior view of the DC power supply connector.....	41
Figure 5.10: Power supply cable .....	42
Figure 5.11: Service USB under the antenna cap .....	43
Figure 5.12: MTC 6 <Power>-key .....	44
Figure 6.1: SMALL keyboard.....	45
Figure 6.2: 24-key keypad .....	45
Figure 6.3: Voice Kit microphone (optional) .....	45
Figure 7.1: Position of the ground bolt.....	49
Figure 7.2: Antenna cap MTC 6 .....	51
Figure 7.3: Opened antenna cap.....	52
Figure 8.1: Software Keyboard.....	53
Figure 8.2: MTC 6 front keys and LEDs .....	54
Figure 9.1: Touch-screen recalibration using UPDD .....	57
Figure 9.2: Touch-screen recalibration using TSHARC.....	58
Figure 11.1: RJ45 network port of MTC 6 Intel.....	60
Figure 11.2: RJ45 network port of MTC 6 AMD .....	60



# 1. About this manual

This manual has been designed to make using the MTC 6 as simple as possible and provide expert assistance if problems should occur. It contains important information on using the device safely, properly and efficiently.

Adhering to the manual helps by avoiding dangers, reducing repair costs and breakdown times and increasing the reliability and lifespan of the MTC 6.

DLoG GmbH will not assume responsibility for any damage caused by the improper use of the MTC 6 and/or in disregard of the instructions in this manual.



Before installing, assembling, and starting the MTC 6, please read this manual carefully and follow all the safety guidelines listed.

Follow all *Basic safety guidelines* and the safety notes in the individual chapters.

Within this manual, DLoG GmbH strives to provide all the information required for using your MTC 6. However, because this is a versatile product that can be used in many different scenarios, we cannot guarantee that the information contained in this manual will cover every single aspect. Should you require further information or if you have questions or issues needing clarification, please contact your nearest DLoG GmbH agent or representative.

## 1.1. For qualified personnel

This manual was written for qualified personnel. The information is intended exclusively to complement the expertise of qualified personnel, not to replace it.

## 1.2. Please read documentation accompanying the product

Please take note of all documentation received for your industrial PC, such as safety information, assembly instructions, etc.

## 1.3. Current manuals and drivers on the internet

Current manuals, drivers, and additional useful information can be found on the internet at: [www.advantech-dlog.com](http://www.advantech-dlog.com) -> Download Menu.

## 1.4. Keep this manual

Please keep this manual for later use.

## 1.5. Design method



Risc of personal injury:

The following levels apply, denoted by the respective keyword.

**DANGER:** There is an immediate risk of death / serious injury

**WARNING:** There is a possible risk of death / serious injury

**CAUTION:** Mild injury is possible



Electromagnetic radiation (non-ionizing)



Explosion hazard

**NOTICE**

NOTICE is used to indicate the risk of physical damage.



This symbol indicates hints that help you to understand how to use the product or the manual.

## 1.6. Trademarks

The software and hardware designations as well as the brand names used in this documentation are in most cases also registered trademarks and are subject to the international law (trademark, brand and protection laws).

Windows® is a registered trademark of Microsoft Corporation in the United States (US) and other countries.

Intel® and Pentium® are registered trademarks of Intel Corp.

Wir recognize all national and international trademarks and product names.

## 2. Basic safety guidelines

- Please read and follow these safety instructions.
- Do not throw them away.

### 2.1. Always install, operate, and maintain the unit properly

The MTC 6 was designed and built according to modern technology and accepted safety regulations. However, the operation of the MTC 6 can endanger personnel or third parties and cause damage to the device and other material assets when for example the device is

- installed incorrectly or improperly.
- operated by untrained or uninstructed personnel.
- improperly operated and maintained.
- not used as intended.

The operator commitments in regards to safety (accident prevention regulations, work protection) are to be followed.

### 2.2. Safety

In order to prevent injury and damage, please read and observe the following safety guidelines prior to assembly and commissioning. The manufacturer assumes no liability for any and all damages that can be attributed to non-compliance with these guidelines.

### 2.3. Intended usage

MTC 6 industrial PCs are multifunctional terminals for stationary and mobile use in commercial environments (e.g. logistics, warehousing, fleet management, manufacturing, automotive).

Any other or additional use is not as intended.

The user/operator of the industrial PC is solely responsible for any resulting damage.

This also applies to unauthorized modifications to the unit.

#### **Area of application: not for use in life-support systems or critical safety systems**

The device is not designed for use in life-support systems or critical safety systems where system malfunction can lead to the direct or indirect endangerment of human life. The operator shall take full responsibility for using the device in these situations.

The device cannot be used in combination with safety functions for machines and equipment which have to conform to the requirements of EN 954-1.

## 2.4. Preventing electrical hazards

### Installing easily accessible separators

Industrial PCs are not equipped with separators (switches) that are accessible from the outside. To enable the devices to be quickly disconnected from the power supply in emergency situations:

- Install an easily accessible separator such as a switch or circuit breaker close to the device.
- Make sure that the separator separates all power supply lines.

### Only connect industrial PCs to SELV circuits

- Only connect industrial PCs to Safety Extra Low Voltage (SELV) circuits.

### Do not connect/disconnect any cables during thunderstorms

- Do not connect/disconnect industrial PC cables during a thunderstorm.

### Servicing/cleaning the unit: Disconnect the industrial PC from the power supply

- Disconnect the industrial PC from the power supply before cleaning or servicing it.

### Power pack fuse blows repeatedly: Send in the unit for repair

If after replacement of the integrated power pack fuse it immediately blows again, there is a risk of electrical shock.



- Send in the industrial PC immediately for repair.

### Lines must be laid in accordance with national regulations

- When laying cables, please follow the appropriate national installation regulations.

### Ensure that the power cable is laid so that it is mechanically protected.

### Use only original power supply cables from Advantech-DLoG

Advantech-DLoG power cables meet the specific requirements for low-temperature flexibility, UV resistance, oil resistance, etc.

- Use only original power supply cables from Advantech-DLoG.

If other power supply cables are used:

- The user/operator of the industrial PC is solely responsible for the resulting damage.
- All warranties by Advantech-DLoG are voided.

### Charging the vehicle battery: Disconnect the industrial PC from the battery

While the vehicle battery is charging:

- The industrial PC must be disconnected from the vehicle battery.
- Or it must be ensured that the maximum permitted input voltage of the device is not exceeded.



**Do not use industrial PCs in locations where flammable gases or vapors are present**

The operation of electrical equipment in explosive environments can be dangerous.

- Turn off the industrial PC when you are near gas stations, fuel depots, chemical plants or places where blasting operations take place.

## 2.5. When mounting please note the following

### Risk of injury during transportation and installation

The device may fall down during transportation or installation and cause injury.

- Ask for help from another person when installing/uninstalling the device.

### Danger if mounting bracket breaks

- When installing the industrial PC, make sure that if the bracket breaks (e.g. because of a stress fracture) no-one will be injured.
- Alternatively please put appropriate safety measures in place (e.g. install a security cable in addition to the mounting bracket).

### Position of the industrial PC on the vehicle: Driver's field of vision must be kept free.

Inside the vehicle the driver's field of vision must be kept free.

- If a keyboard and scanner are to be installed, allow space for them.

### Installing industrial PCs with loudspeakers

Industrial PCs with loudspeakers must be installed by appropriately trained staff. Incorrect installation or servicing can be dangerous.



### Deployment location: Note IP protection class and permissible ambient conditions

The permissible ambient conditions are described in chapter 3.4.21. *Ambient conditions.*

### Before use: Install cable cover

Ensuring the IP protection of industrial PCs:

- Before use the supplied cable cover for the external connections must be installed.

### No fresh air supply / overheating causes material damage

The industrial PC operates on the basis of a passive cooling concept according to which internal waste heat is released via the housing surface. The prerequisite for the concept is a supply of fresh air.

- If no fresh cooling air is supplied to the PC, this can cause overheating and lead to the destruction of the unit.
- The installation environment should not result in a closed system that prevents passing cold air from releasing absorbed heat.

## 2.6. Connect / disconnect external devices

Disconnect the industrial PC from the power supply before connecting / removing peripheral devices (this does not apply to USB devices)

Otherwise considerable damage could be caused to both the industrial PC and the peripheral devices.

**NOTICE:**  
Property  
damage

- Make sure that peripherals with their own power supply are either switched on at the same time as the industrial PC or after the industrial PC is switched on.
- If you don't do this, you must ensure that a backflow from the external device to the industrial PC cannot take place.

**Only use authorized accessories**

- Only use the cables, power packs and other accessories that have been tested and approved for the respective industrial PC by Advantech-DLoG.
- Ask your Advantech-DLoG sales representative about authorized accessories.

## 2.7. Transmission of radio frequencies

**Note the permitted transmission power**

The maximum permitted transmission power for the respective country must not be exceeded. Responsibility for this lies with the operator of the industrial PC.

**Installation note: Keep a minimum distance of 20 cm between individuals and antennas**

To ensure that the limits set by the FCC for exposure to radio waves are not exceeded:

- Install the industrial PC in such a way that the minimum distance between individuals and the PC antenna is 20 cm.



**Do not use industrial PCs without permission in aircraft or hospitals**

Some technical equipment in hospitals and aircraft are not immune to radio frequency energy.

- Do not use industrial PCs in aircraft or hospitals without receiving prior authorization. Use in both is only permitted if such authorization has been received.

**Do not use an industrial PC near pacemakers**

Industrial PCs can affect the functioning of implanted medical devices such as pacemakers and cause them to malfunction.

- Do not use an industrial PC near pacemakers.
- Always keep a distance of at least 20 cm between a pacemaker and an industrial PC to reduce the risk of interference.

## 2.8. Clean / maintain industrial PC



**Servicing / cleaning the device: Disconnect the industrial PC from the power supply**

- Disconnect the industrial PC from the power supply before cleaning or servicing it.
- Never clean the industrial PC with compressed air, a pressure washer or a vacuum cleaner.
- If necessary, clean the housing of the industrial PC with a damp cloth.
- Clean the touch-screen with a non-abrasive cloth dampened with water.

## 2.9. Modifications and repairs only by Advantech-DLoG



**Modifications to the industrial PC are not allowed.**

**Opening the industrial PC is not allowed.**

All warranties by Advantech-DLoG relating to the industrial PC are voided by modifications / by opening the unit.

**Do not carry out any repairs on the industrial PC yourself.**

- Always contact the responsible technical service officer at Advantech-DLoG and send in your unit for repair if necessary.
- Refer to the nameplate on the back of the unit for important technical service information.

## 2.10. CE Marking

Remark for CE class A products: Class A products may be used in residential environment but with the condition that the end user is informed about the possible consequence with a warning information in the user manual:

Warning! This is a class A device. This equipment may cause interference in a residential installation. In this case the user is encouraged to perform appropriate measures to correct the interference.

## 2.11. RTTE Directive 1999/5/EC

With regard to the RTTE Directive 1999/5/EC the statements in the declaration of conformity for the MTC 6 (see page 2 of this manual) apply.

Česky [Czech]:	Toto zařízení je v souladu se základními požadavky a ostatními odpovídajícími ustanoveními Směrnice 1999/5/EC.
Dansk [Danish]:	Dette udstyr er i overensstemmelse med de væsentlige krav og andre relevante bestemmelser i Direktiv 1999/5/EF.
Deutsch [German]:	Dieses Gerät entspricht den grundlegenden Anforderungen und den weiteren entsprechenden Vorgaben der Richtlinie 1999/5/EU.
Eesti [Estonian]:	See seade vastab direktiivi 1999/5/EÜ olulistele nõuetele ja teistele asjakohastele sätetele.
English:	This equipment is in compliance with the essential requirements and other relevant provisions of Directive 1999/5/EC.
Español [Spanish]:	Este equipo cumple con los requisitos esenciales así como con otras disposiciones de la Directiva 1999/5/CE.
Ελληνική [Greek]:	Αυτός ο εξοπλισμός είναι σε συμμόρφωση με τις ουσιώδεις απαιτήσεις και άλλες σχετικές διατάξεις της Οδηγίας 1999/5/EC.
Français [French]:	Cet appareil est conforme aux exigences essentielles et aux autres dispositions pertinentes de la Directive 1999/5/EC.
Íslenska [Icelandic]:	Þetta tæki er samkvæmt grunnkröfum og öðrum viðeigandi ákvæðum Tilskipunar 1999/5/EC.
Italiano [Italian]:	Questo apparato é conforme ai requisiti essenziali ed agli altri principi sanciti dalla Direttiva 1999/5/CE.
Latviski [Latvian]:	Šī iekārta atbilst Direktīvas 1999/5/EK būtiskajām prasībām un citiem ar to saistītajiem noteikumiem.
Lietuvių [Lithuanian]:	Šis įrenginys tenkina 1999/5/EB Direktyvos esminius reikalavimus ir kitas šios direktyvos nuostatas.
Nederlands [Dutch]:	Dit apparaat voldoet aan de essentiële eisen en andere van toepassing zijnde bepalingen van de Richtlijn 1999/5/EC.
Malti [Maltese]:	Dan l-apparat huwa konformi mal-htigiet essenzjali u l-provedimenti l-oħra rilevanti tad-Direttiva 1999/5/EC.
Magyar [Hungarian]:	Ez a készülék teljesíti az alapvető követelményeket és más 1999/5/EK irányelvben meghatározott vonatkozó rendelkezéseket.
Norsk Norwegian [Norwegian]:	Dette utstyret er i samsvar med de grunnleggende krav og andre relevante bestemmelser i EU-direktiv 1999/5/EF.
Polski [Polish]:	Urządzenie jest zgodne z ogólnymi wymaganiami oraz szczególnymi warunkami określonymi Dyrektywą UE: 1999/5/EC.
Português [Portuguese]:	Este equipamento está em conformidade com os requisitos essenciais e outras provisões relevantes da Directiva 1999/5/EC.
Slovensko [Slovenian]:	Ta naprava je skladna z bistvenimi zahtevami in ostalimi relevantnimi pogoji Direktive 1999/5/EC.
Slovensky [Slovak]:	Toto zariadenie je v zhode so základnými požiadavkami a inými príslušnými nariadeniami direktív: 1999/5/EC.
Suomi [Finnish]:	Tämä laite täyttää direktiivin 1999/5/EY olennaiset vaatimukset ja on siinä asetettujen muiden laitetta koskevien määräysten mukainen.
Svenska [Swedish]:	Denna utrustning är i överensstämmelse med de väsentliga kraven och andra relevanta bestämmelser i Direktiv 1999/5/EC.



### 2.11.1. Special rule/restriction

For the MTC 6 with WLAN 802.11a/b/g/n, the following restrictions apply:

- In Germany, WLAN 5 GHz band: 5.15 GHz – 5.35 GHz may only be used indoors.
- In France, WLAN operation outdoors is only permitted in the 2454 – 2483.5 MHz range at max. 10 mW EIRP.

## 2.12. FCC user information

### Declaration of the Federal Communications Commission

This equipment has been tested and found to comply with the limits for a Class A digital device, pursuant to Part 15 of the FCC Rules and meets all requirements of the Canadian Interference-Causing Equipment Standard ICES-003 for digital apparatus. These limits are designed to provide reasonable protection against harmful interference in a residential installation. This equipment generates, uses, and can radiate radio frequency energy and, if not installed and used in accordance with the instructions, may cause harmful interference to radio communications. However, there is no guarantee that interference will not occur in a particular installation. If this equipment does cause harmful interference to radio or television reception, which can be determined by turning the equipment off and on, the user is encouraged to try to correct the interference by one or more of the following measures:

- Reorient or relocate the receiving antenna.
- Increase the separation between the equipment and receiver.
- Connect the equipment into an outlet on a circuit different from that to which the receiver is connected.
- Consult the dealer or an experienced radio/T.V. technician for help.

Advantech-DLoG is not responsible for any radio television interference caused by unauthorized modifications of this equipment or the substitution or attachment of connecting cables and equipment other than those specified by Advantech-DLoG. The correction of interference caused by such unauthorized modification, substitution or attachment will be the responsibility of the user. The use of shielded I/O cables is required when connecting this equipment to any and all optional peripheral or host devices. Failure to do so may violate FCC and ICES rules.



FCC warning: Any change or modification which is not expressly approved in the corresponding pages can lead to the withdrawal of the operating license for this device.

In order to comply with the FCC requirements regarding radio frequency exposure from vehicle-mounted transmission devices the antenna has to be kept at least 20 cm away from people.

### 3. Device description – Technical specifications

Thank you for choosing the MTC 6.



Figure 3.1: 15" model MTC 6 series

#### 3.1. Device models

This manual applies to the following models of the MTC 6:

- MTC 6 with 10.4" display
- MTC 6 with 12.1" display
- MTC 6 with 15.0" display
- MTC 6 Series with Intel CPU
- MTC 6 Series with AMD APU

Any differences between the devices will be clearly noted in this manual.

#### 3.2. Abbreviations used for devices and accessories

Please note that to save space on the MTC 6 and supplied accessories, the following abbreviations have been used:

Abbreviation	Explanation
+	DC+
-	DC-
Ign	Ignition

### 3.3. Device/type identification

The device type plate on the MTC 6 contains the following information:

MTC 6/10 or MTC 6/12 or MTC 6/15	Describes the device MTC 6 with a 10.4", 12.1" or 15.0" display
SVGA or XGA	Display resolution
DC	Type of power supply, the following number indicate the exact type of power supply with input voltage
e.g. 24/48V with 2.5 A / 1.2 A	Input voltage of the DC power supply with nominal current
1.1 GHz or 1.0 GHz	Clock rate of the CPU
S/N ....	12 digit serial number composed of: <ul style="list-style-type: none"> <li>– Advantech-DLoG specific device code (41 stands for the MTC 6 model range with Intel CPU, 42 stands for the MTC 6 model range with AMD APU)</li> <li>– Week and year of manufacture</li> <li>– Six digits for identification</li> </ul>

### 3.4. Technical specifications

3.4.1. MTC 6 Intel: CPU, Cache, RAM	
CPU Chipset Cache	Intel® Atom™ processor Z510 1.1 GHz, 400 MHz FSB and 400 MHz memory bus speed, 512 k L2 cache, 45 nm Chipset Intel® SCH US15W
RAM	1 GB RAM DDR2-Technology
BIOS	AMIBIOS8® - Flash BIOS with ACPI, PnP Programmable in the system, BIOS POST self test
Real-time clock	Real-time clock with a power reserve of up to 5 years
CFast	> 4 GB Flash media, based on SLC technology (single level cell)

3.4.2. MTC 6 AMD: APU, Cache, RAM	
APU Chipset Cache	AMD APU (Advanced Processing Unit) G-T40R 1.0 GHz, 512 kB L2 cache and 1066 MHz memory bus speed  Or: AMD APU (Advanced Processing Unit) Dual Core G-T40E 1.0 GHz, 2x 512 kB L2 cache and 1066 MHz memory bus speed
RAM	2 GB RAM DDR3-Technology
BIOS (UEFI)	AMI Aptio UEFI, 4 MByte serial SPI firmware flash mit ACPI, PnP Programmable in the system, BIOS POST self test
Real-time clock	Real-time clock with a power reserve of up to 5 years
CFast	> 4 GB Flash media Based on SLC technology (single level cell)

3.4.3. Housing - Mechanical	
Material	Rugged aluminum-cast housing with integrated heat sink Protection class IP 65, IP 66 und IP 67 ESD safe
Weight	10.4" : 3.0 kg 12.1" : 3.5 kg 15.0" : 4.9 kg
Dimensions	See Chapter 3.5 <i>Dimensions</i>

3.4.4. MTC 6 Intel: Display	
MTC 6/10	10.4" SVGA 400 cd/m <sup>2</sup> Brightness adjustment Optional: Sun light readable
MTC 6/12	12.1" XGA 600 cd/m <sup>2</sup> Brightness adjustment Optional: Sun-light readable
MTC 6/15	15.0" XGA 400 cd/m <sup>2</sup> Brightness adjustment

3.4.5. MTC 6 AMD: Display	
MTC 6/10	10.4" SVGA 400 cd/m <sup>2</sup> Brightness adjustment Optional: Sun light readable
MTC 6/12	12.1" XGA 400 cd/m <sup>2</sup> Brightness adjustment Optional: Sun-light readable
MTC 6/15	15.0" XGA 400 cd/m <sup>2</sup> Brightness adjustment

3.4.6. Operating systems (optional) for MTC 6 Intel	
Microsoft®	Windows® XP Professional Windows® Embedded Standard 2009 Windows® Embedded Standard 7
Linux	Generic with Gnome

3.4.7. Operating systems (optional) for MTC 6 AMD	
Microsoft	Windows® XP Professional Windows® Embedded Standard 2009 Windows® Embedded Standard 7 Windows® 7 Professional

3.4.8. Serial port	
Serial port	COM1 Max. 115.200 Baud (16550A compatible, 16 byte FIFO), supports RS-232 on an external 9pin D-Sub connection ESD level 4 protected (acc. to EN 61000-4-2) COM1 optional 5 V

3.4.9. USB, Service USB	
USB-connection	2 x USB 2.0 Host Properties: USB 2.0 HiSpeed Fused at 0.5 A per channel Fused for ESD level 4 (compliant with EN 61000-4-2) For example for mouse, keyboard, USB stick
Service USB	1 x USB 2.0 Host Service-connection under antenna cap USB-A (USB 2.0 low / full / high speed) Fused at 0.5 A

**3.4.10. MTC 6 Intel: LCD interface**

VGA controller	Intel® Graphics Media Accelerator 500 (Intel® GMA 500), up to 256 MByte frame buffer supporting Direct X 9.0E and Open GL 2.0 Shared Memory architecture Resolution up to 1366 x 768 pixels Up to 24 bit color depth, depending on which LCD is used
----------------	---

**3.4.11. MTC 6 AMD: LCD interface**

VGA Controller	Integrated High Performance Video AMD Radeon™ HD 6250 DirectX®11 graphics with UVD 3.0 for H.264, VC-1 and MPEG2 Shader Model 5, OpenCL™ 1.1, OpenGL 4.0 GPU Core Frequency 280MHz Shared Memory architecture up to 512 MB Resolution up to 1400 x 1050 Pixel Up to 24 bit color depth, depending on which LCD is used
----------------	---

**3.4.12. Touch interface**

Analog touch controller	12bit touch controller for touch screens with RS232 interface.
-------------------------	--

**3.4.13. MTC 6 Intel: Network interface**

Network controller	Ethernet Realtek RTL8111 10/100/1000 MB/s
Network connection	RJ45 plug-in connector Integrated transmitter Two integrated status LEDs

**3.4.14. MTC 6 AMD: Network interface**

Network controller	Ethernet Intel® 82574 10/100/1000 MB/s
Network connection	RJ45 plug-in connector Integrated transmitter Integrated status LED

3.4.15. Integrated speaker/sound)	
<p>Speaker</p>  <p>Figure 3.2: Speaker (MTC 6 back)</p>	<p>The MTC 6 is equipped with an internal speaker as standard Driver integrated in the image.</p>

3.4.16. Voice Kit (optional)	
 <p>Figure 3.3: Voice Kit handset microphone (optional)</p>	<p>The optional MTC 6 Voice Kit includes a handset microphone incl. a speaker system and mounting bracket. Once the Voice Kit is connected, the internal MTC 6 speaker system is automatically deactivated. The handset microphone is connected to the MTC 6 Audio/Mic interface (see Chapter 5.11 <i>External connectors</i>).</p>



3.4.17. Integrated WLAN antenna (optional)	
	<p>Gain (without cable lost): 3 dBi max.                      Frequency band:                      2400 to 2485 MHz / 5150 to 5875 MHz                      Impedance: 50 Ω                      VSWR (voltage standing-wave ratio): &lt; 2                      Polarization: vertical                      Max. power: 1 W (CW) @ 25°C</p>
<p>Figure 3.4: Integrated antenna</p>	

3.4.18. Remote WLAN antenna (optional)	
	<p>Gain: 4 dBi max.                      Frequency band: 2400 to 5875 MHz                      Dimensions: Ø 86 x 43 mm (Ø 3.39" x 1.69")                      Weight: 0.3 kg (0.66 lbs)                      Polarization: linear, vertical                      3 m antenna cable included</p>
<p>Figure 3.5: Remote antenna</p>	



MTC 6 Intel: Power consumption	
MTC 6/10	typ. 20 W
MTC 6/12	typ. 25 W
MTC 6/15	typ. 25 W
Standby typically 1 W	

MTC 6 AMD: Power consumption	
MTC 6/10	typ. 25 W
MTC 6/12	typ. 30 W
MTC 6/15	typ. 30 W
Standby typically 1 W	

### 3.4.20. Power supply fuses

The symbol for the fuse is FA. You will find the exact position on the sticker located on the connection plate.

Power supply	Fuse type	Examples
DC-11 DC-13	5 x 20 mm T 10 A H / 250 V	Bussman S505-10A Wickmann 181-10A Littelfuse 215 10 Siba 70 007 65 10A Elu 179200 10A or similar devices produced by other manufacturers
DC-12 DC-14	5 x 20 mm T 4 A H / 250 V	Bussman S505-4A Wickmann 181-4A Littelfuse 215 04 Siba 70 007 65 4A Elu 179200 4A or similar devices produced by other manufacturers

3.4.21. Ambient conditions	
Operating temperature	-30° to +50° C In accordance with EN 60068-2-1/2
Storage temperature	-30° to +65 °C In accordance with EN 60068-2-1/2
Relative humidity	10% to 90% @ 40°C non-condensating In accordance with EN 60068-2-3
Mechanical vibration and shock-resistance	Class 5M3 according to EN 60721-3-5: 1998 (Land vehicles), 5 hrs. noise 3.6 g effektive and 36 vibrations with 30 g peaks Or: US Highway Truck according to MIL-STD 810 G: 2000 (Department of Defense), 3 hrs. noise 1 g effektive and 600 vibrations 20 g peaks in operation

### 3.5. Dimensions

#### 3.5.1. MTC 6/10

Front view

Dimensions without add-ons (in mm):

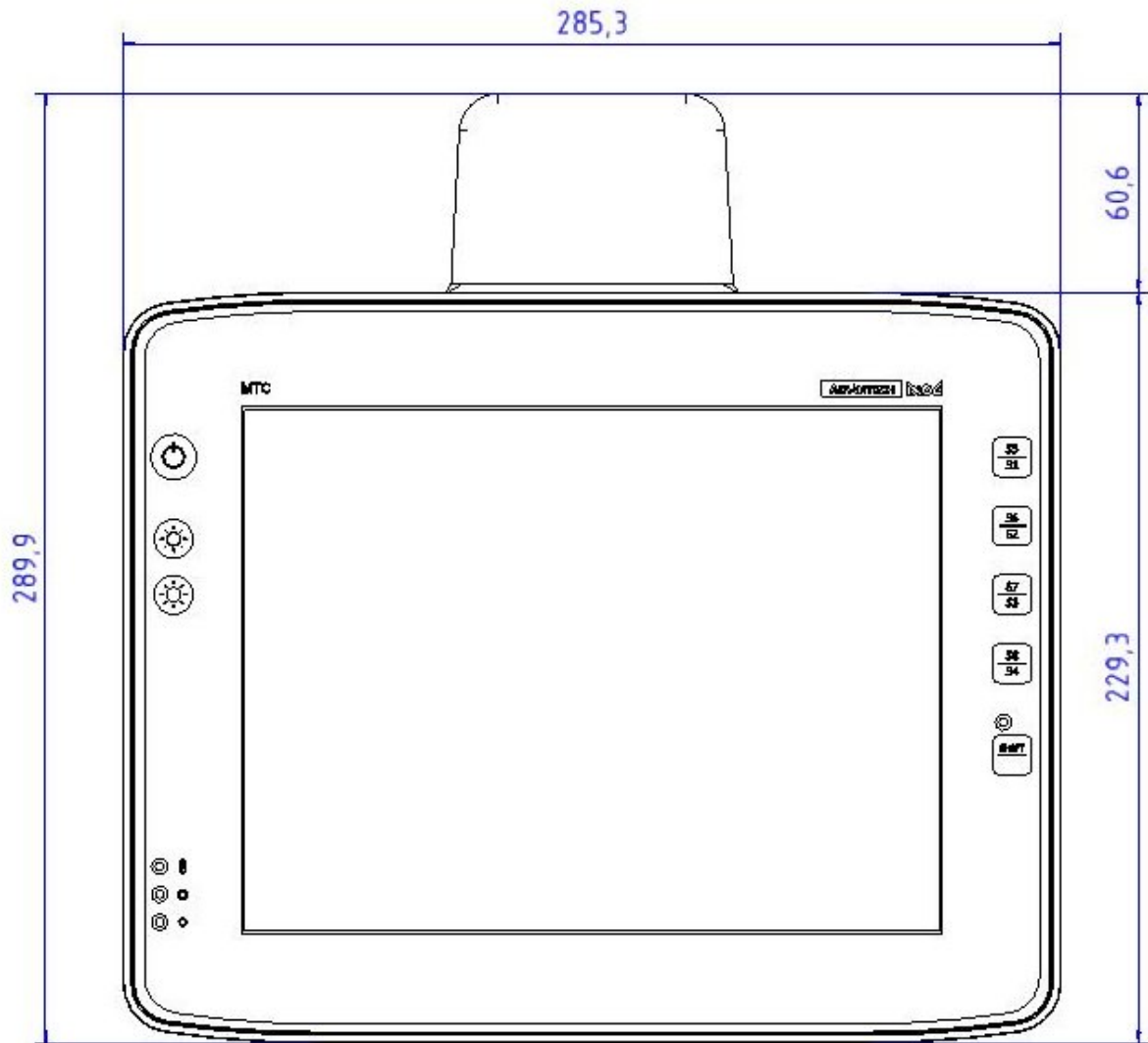

Figure 3.6: Dimensions MTC 6/10 front view

Side view

Dimensions without add-ons (in mm):

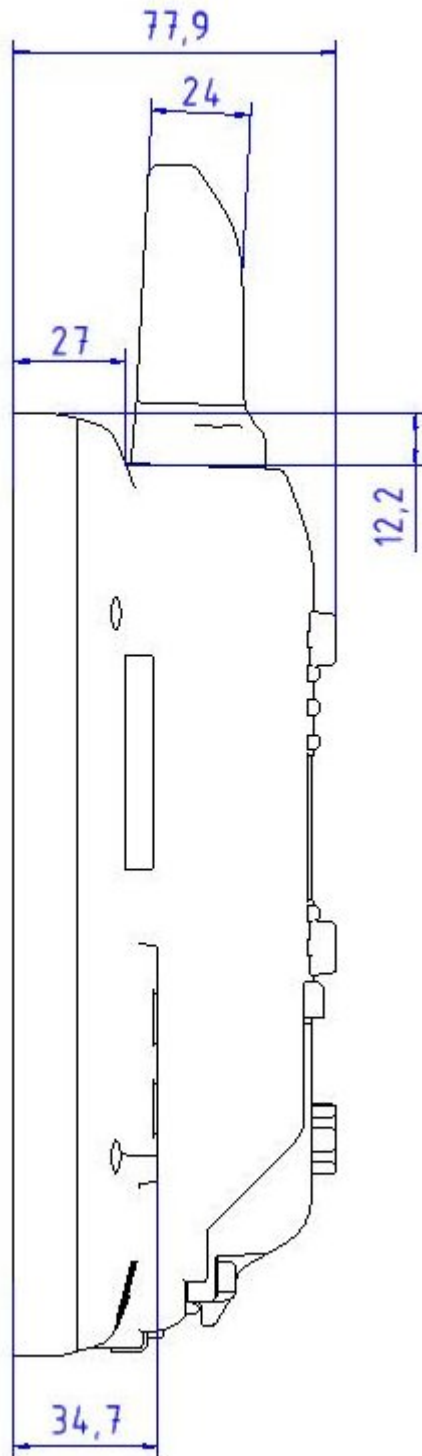

Figure 3.7: Dimensions MTC 6/10 side view

Top view

Dimensions without add-ons (in mm):

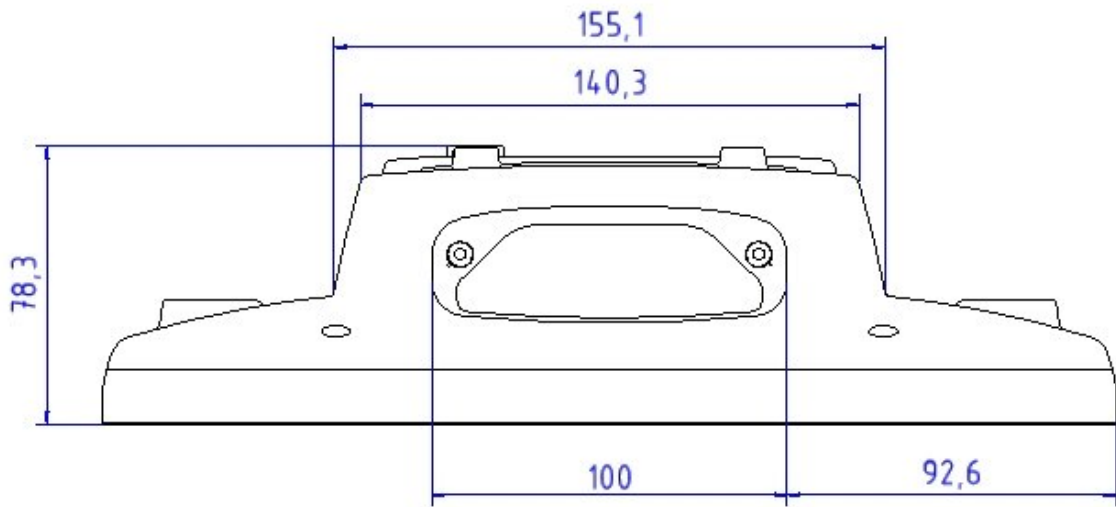

Figure 3.8: Dimensions MTC 6/10 top view

3.5.2. MTC 6/12

Front view

Dimensions without add-ons (in mm):

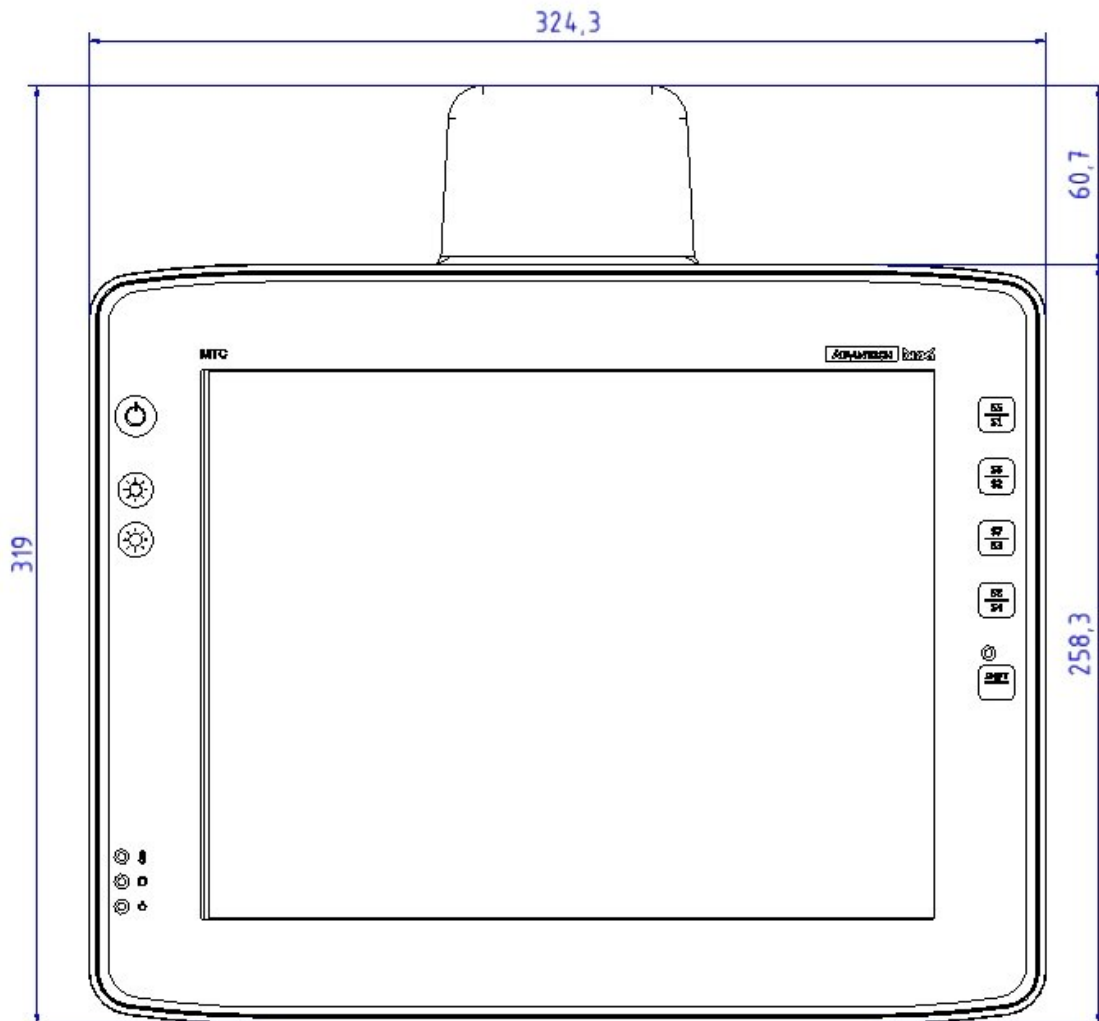

Figure 3.9: Dimensions MTC 6/12 front view



Side view

Dimensions without add-ons (in mm):

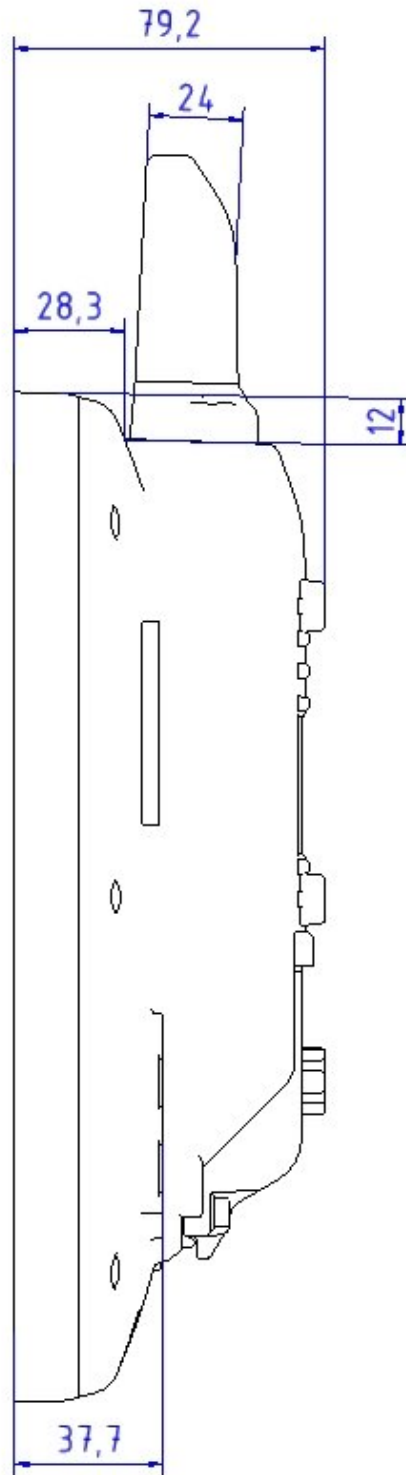

Figure 3.10: Dimensions MTC 6/12 side view

Top view

Dimensions without add-ons (in mm):

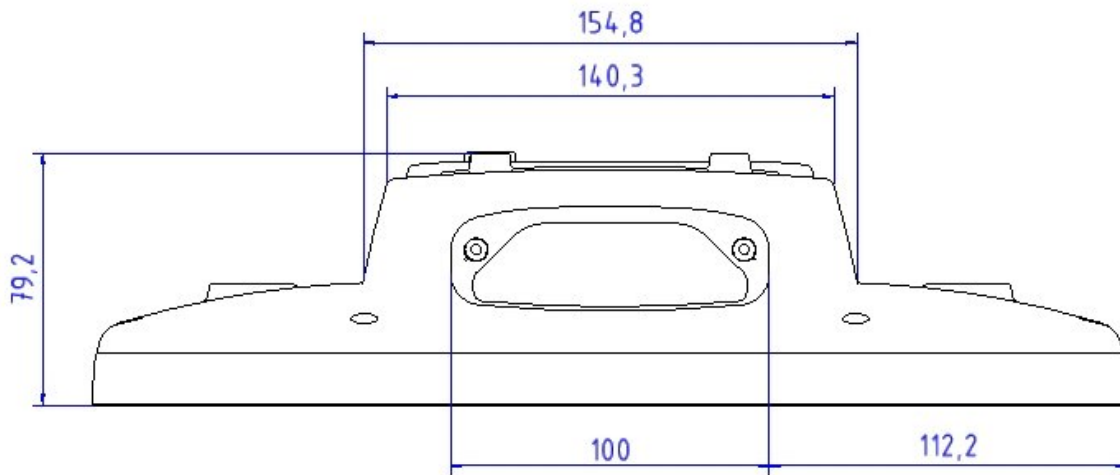

Figure 3.11: Dimensions MTC 6/12 top view

3.5.3. MTC 6/15

Front view

Dimensions without add-ons (in mm):

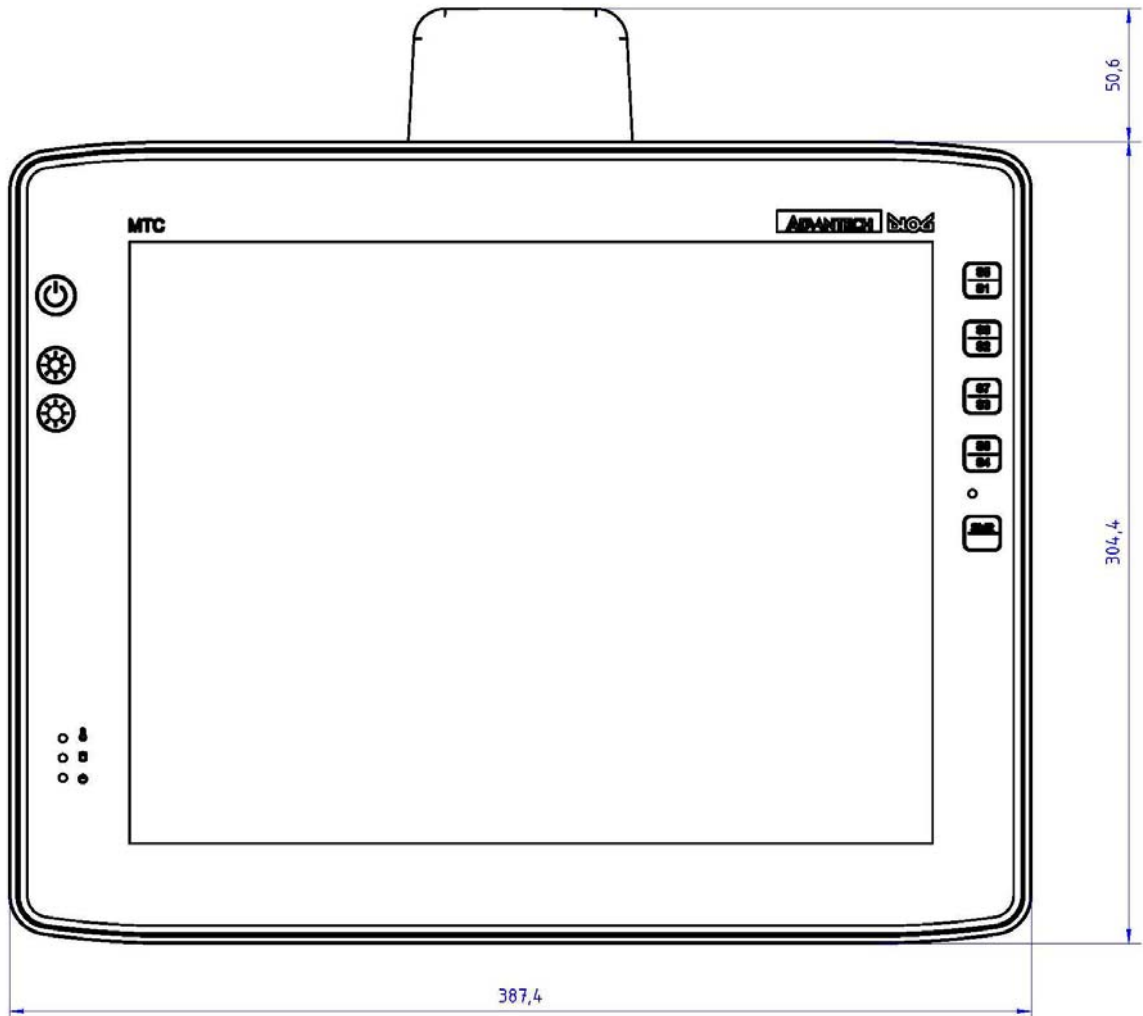

Figure 3.12: Dimensions MTC 6/15 front view

Side view

Dimensions without add-ons (in mm):

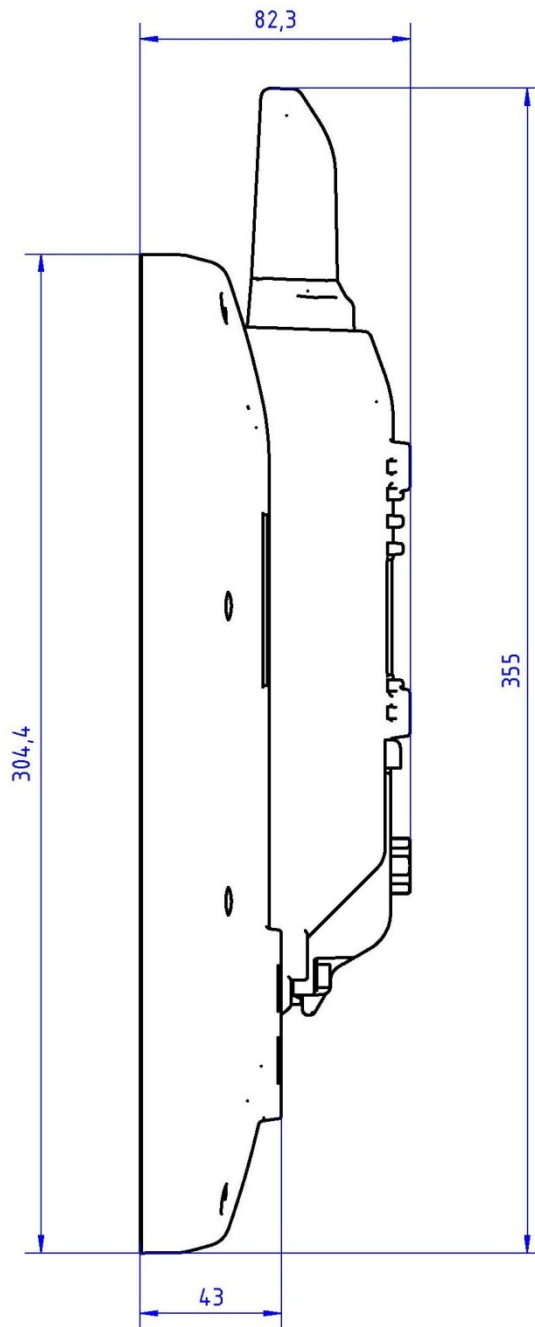

Figure 3.13: Dimensions MTC 6/15 side view

Top view

Dimensions without add-ons (in mm):

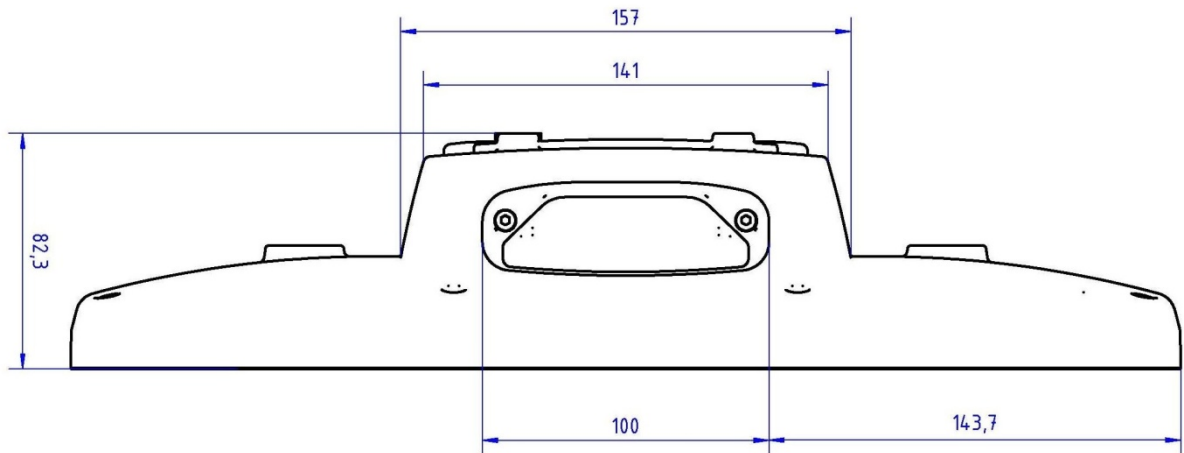

Figure 3.14: Dimensions MTC 6/15 top view

### 3.6. VESA drill holes

#### 3.6.1. MTC 6/10

Dimensions without add-ons (in mm):

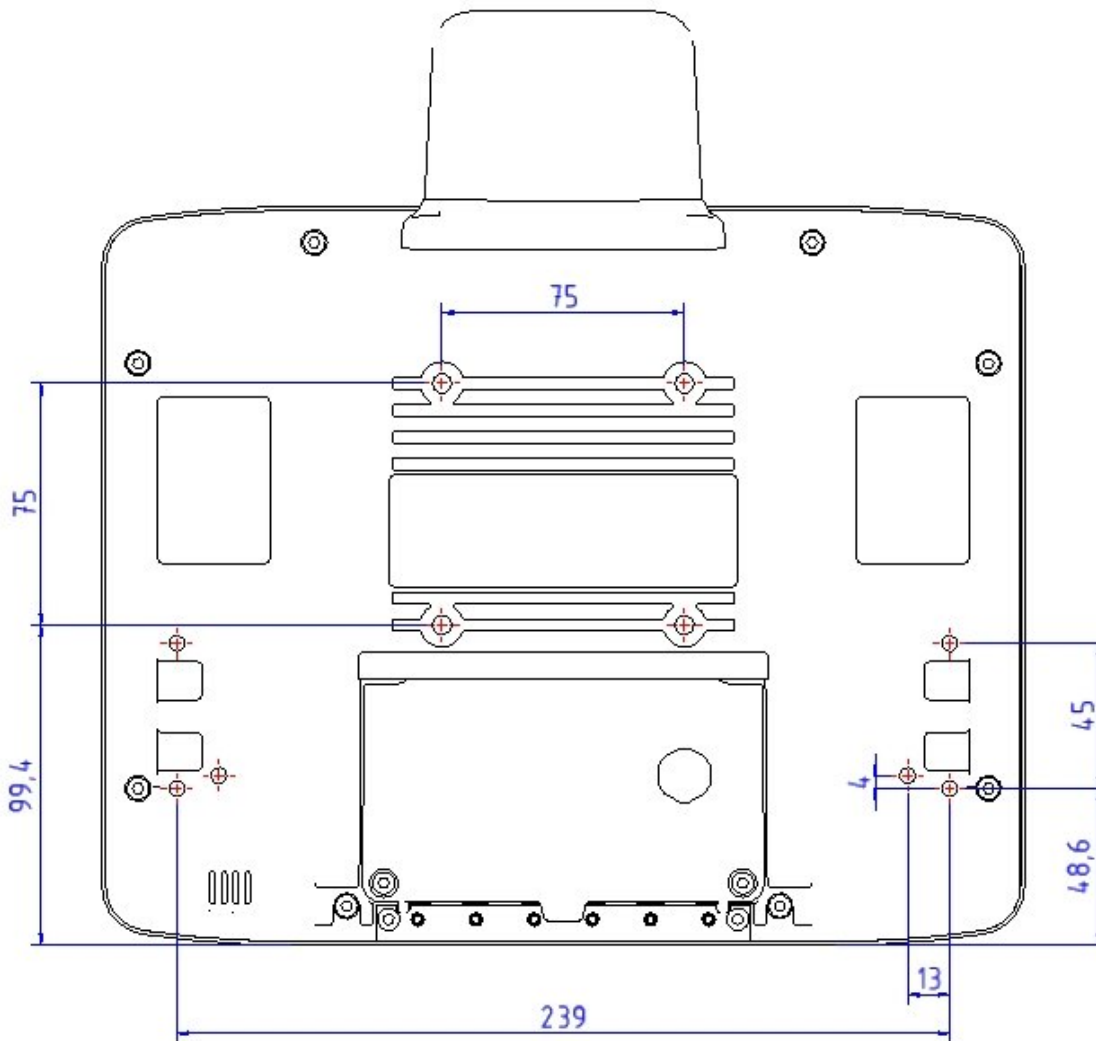

Figure 3.15: Position of the VESA drill holes MTC 6/10

3.6.2. MTC 6/12

Dimensions without add-ons (in mm):

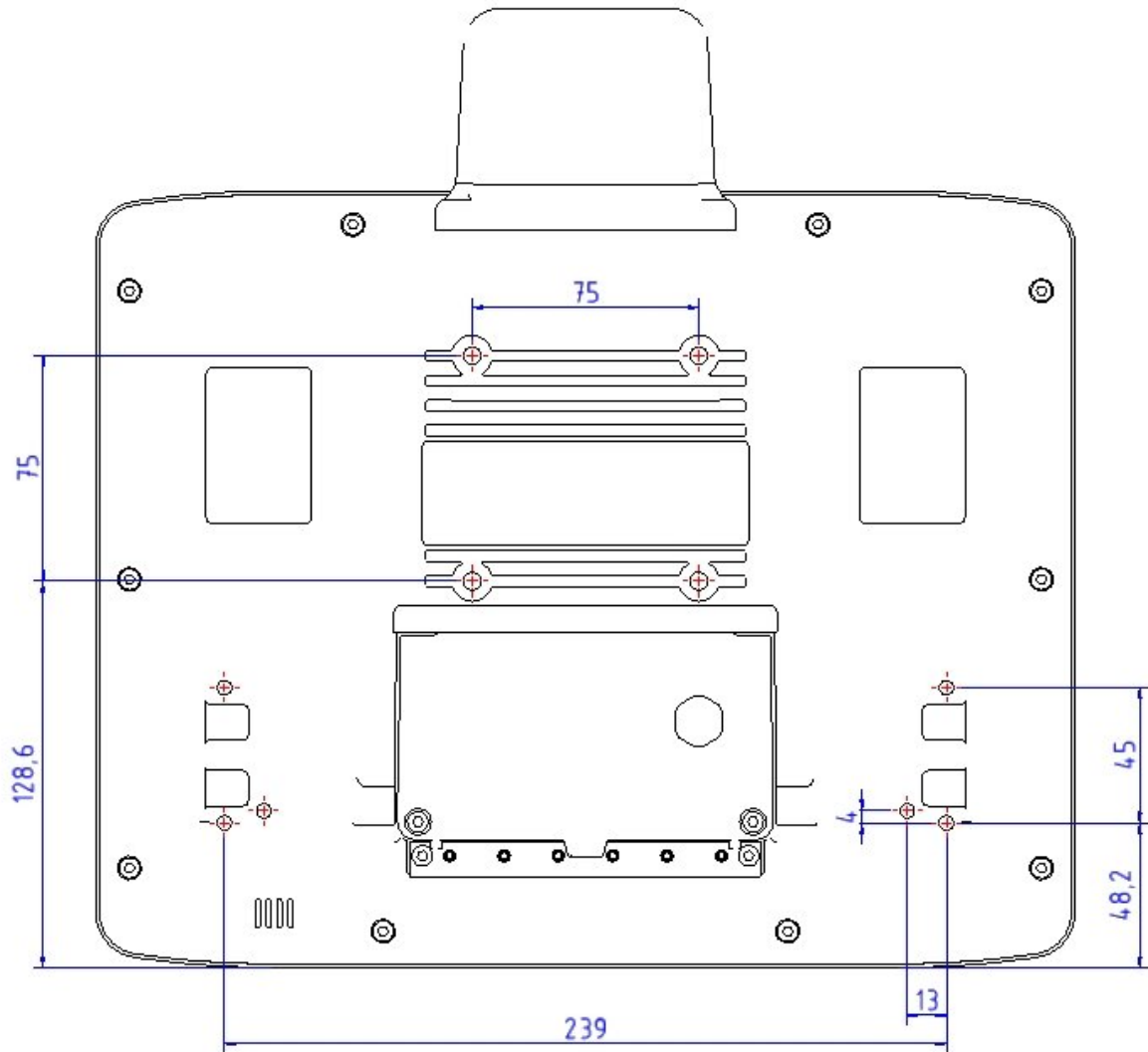

Figure 3.16: Position of the VESA drill holes MTC 6/12

3.6.3. MTC 6/15

Dimensions without add-ons (in mm):

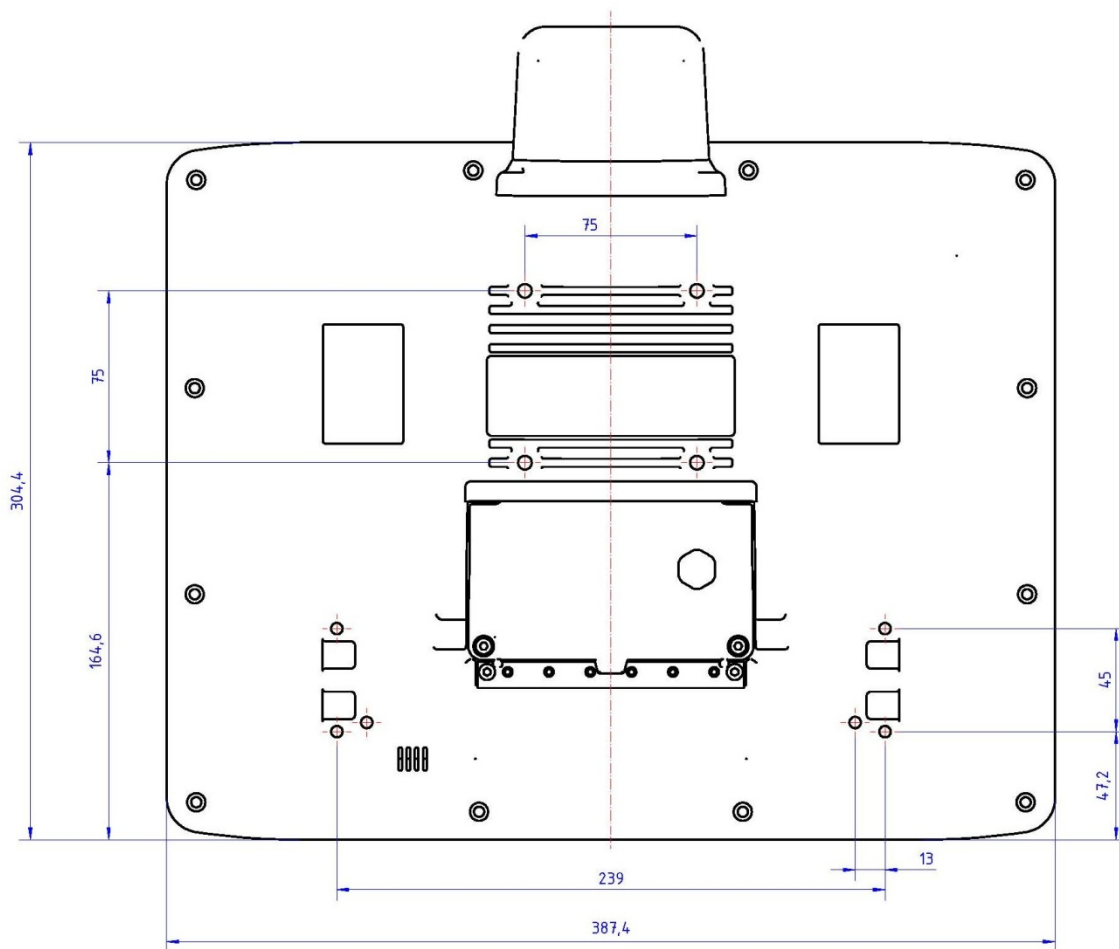

Figure 3.17: Position of the VESA drill holes MTC 6/15



## 4. Unpacking the device

### 4.1. Scope of delivery

The delivery includes at least the following:

- MTC 6
- Cable cover
- Optionally ordered assembly set
- Optionally ordered accessories

Please verify the delivery contents immediately on receipt!

### 4.2. Packaging

The packaging material has been selected to optimally protect your device while simultaneously offering the best possible ecological compatibility. We therefore kindly request that you store the original packaging material or ensure it is used for another suitable purpose such as transporting the unit or returning shipment.

<b>NOTICE:</b> Property damage	If you repack the device, please ensure that the cling wrap in the cardboard frame is positioned towards the front of the device so that it can provide the proper protection.
-----------------------------------	--

### 4.3. Returning your device

Due care was exercised when putting together the contents of your delivery and dispatching your device. Nevertheless, if you still have cause for complaint, please complete the form included in the appendix.

Should you need to return the device, please use the original packaging.

## 5. Initial operation



**WARNING:**

Before operating the unit for the first time, carefully read the *Basic safety guidelines* at the start of this manual.



Please follow the safety guidelines and the quick start instructions you received with your MTC 6 before operating it for the first time.

Configure the MTC 6 before fastening it to machines or vehicles. Software configuration for the WLAN, shutdown automation, etc. is significantly simpler and more convenient on the desktop.

### 5.1. MTC 6 with Linux operating system

Configuration details regarding WLAN, touch screen calibration etc. for the MTC 6 with the Linux operating system are described in a separate Linux operating manual.

That operating manual can be found online in our Download Center at [www.advantech-dlog.com](http://www.advantech-dlog.com) (Login required).

### 5.2. MTC 6 with MS Windows operating system

Configuration details for the MTC 6 with the MS Windows operating system are set out in the sections below.

### 5.3. Images for Intel and AMD devices are not compatible



Images for MTC 6 devices with an Intel processor cannot be used on devices with an AMD processor as they are incompatible. Equally, images for MTC 6 AMD devices cannot be run on Intel devices.

If the wrong image is used, a blue screen appears with the following technical information:  
0X000007B.

### 5.4. Pre-installed on Flash

When a MTC 6 with a pre-installed operating system is started, this operating system is loaded following the BIOS boot messages. System-specific device drivers – such as those for graphic, sound, network and touch screens – are also pre-installed. In MTC 6 units with a pre-installed operating system, the system is located on the C partition.

## 5.5. Installing on Flash

When a MTC 6 is started up for the first time without a pre-installed operating system, the user needs to carry out a number of steps that will vary depending on the system to be installed. Refer to the relevant operating system manual for specific instructions.

**NOTICE:** The installation and configuration of the operating system should only be carried out by professionals familiar with the system environment.  
Property damage

## 5.6. DLoG Config: Front keys, automatic switch-off ...

The program DLoG Config can be found on your MTC 6. Use it for settings like the following:

- Configuring the front keys of the MTC 6
- Setting up the WLAN status display
- Turning the MTC 6 on and off together with the vehicle ignition (automatic switch-off)



For configuring MTC 6 AMD devices, Config Tool Version 3.1.1.0 (or higher) is required. Find detailed information in the user manual for the Config program in our Download Center ([www.advantech-dlog.com](http://www.advantech-dlog.com)).

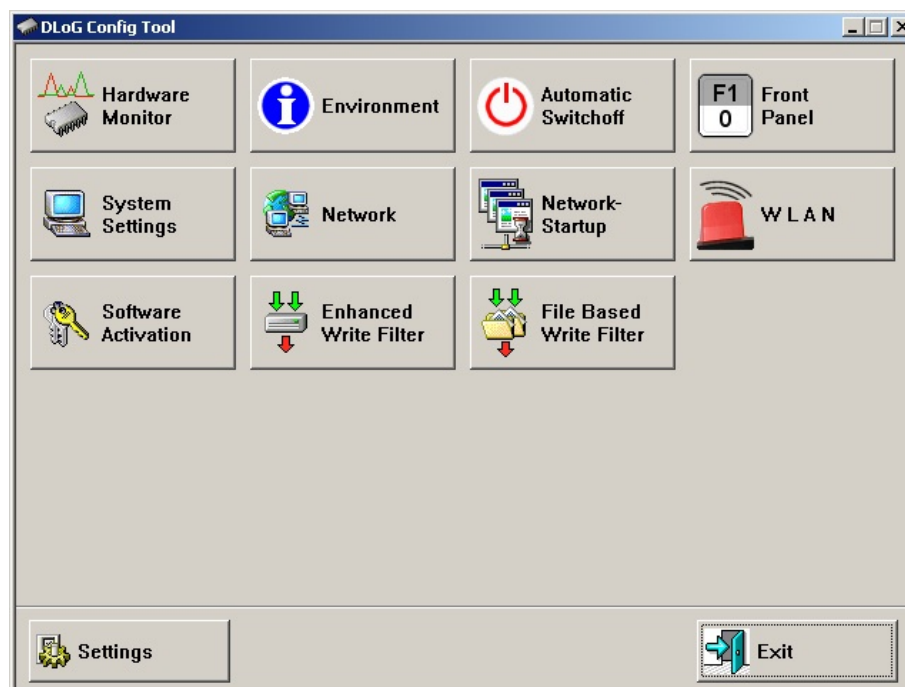

Figure 5.1: DLoG Config Program Menu

## 5.7. WLAN settings

The settings and access data form must be defined for radio networks like WLAN depending on the optional equipment and intended use of the MTC 6.

### 5.7.1. Radio performance



#### WARNING

Do not exceed the maximum permissible transmitting power which is specified by each separate country. MTC 6 users must verify this themselves.

Please keep in mind the configuration for the transmitting power:

- Wireless card (programmed driver capacity)
- Connecting cables
- Antenna gain

Help table for the correct setting:

Translation between mW and dBm																						
dBm	-1	2	5	6	7	8	9	10	11	12	13	14	15	16	17	18	19	20	21	22	23	24
mW	1	2	3	4	5	6	8	10	12	15	20	25	30	40	50	60	80	100	125	150	200	250

### 5.7.2. Antenna solutions for use in Germany

The integrated Advantech-DLoG antenna solutions are based on the prevailing IEEE 802.11 standard. This standard allows wireless data transfer at rates from 1 Mbps to 54 Mbps using the 2.4 GHz and 5 GHz frequency band (300 Mbps if using IEEE 802.11n).

**WARNING**



In Germany according to regulations published in the gazette 89/2003 of the RegTP (regulating body for telecommunications and mail), now: “Bundesnetzagentur” - Federal network agency for electricity, gas, telecommunications, post and railway - the maximum permissible transmitting power, EIRP (equivalent isotropically radiated power), in the 2.4 GHz frequency band is set at 20 dBm.

The transmitting power of the integrated Advantech-DLoG antenna ( 3 dBi) must be set to 50 mW (17 dBm) so that the EIRP limit value is adhered to when using the antenna.

Example configuration of the transmission power using the Summit Client Utility program (you can find more information about this program on the following pages):

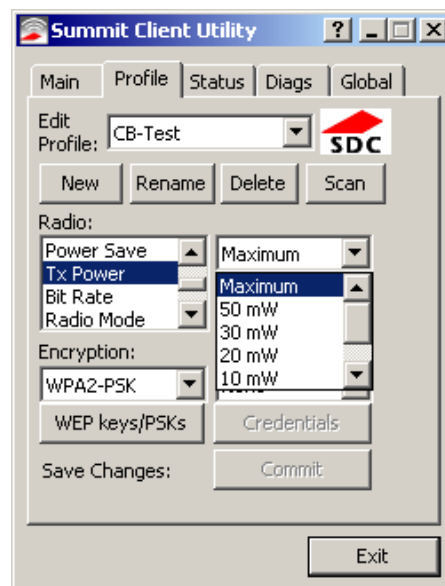



Figure 5.2: Configuring the antenna transmitting power with SCU (example)

### 5.7.3. Summit Client Utility for WLAN configuration

The Summit Client Utility (called "SCU" below) is used to set up the WLAN configuration for the MTC 6.

	<p><b>WARNING</b></p> <p>WLAN configurations may only be modified by qualified IT technical staff.</p>
---	--

Start the SCU with a double press on the SCU icon on the desktop:



Figure 5.3: Summit Client Utility Icon

Alternatively, you can also start the SCU with one of the following procedures:

- From the Start menu: Start | Programs | Summit | Summit Client Utility.
- Or from the Wi-Fi icon on the Control Panel, which you can reach from Start | Settings | Control Panel:

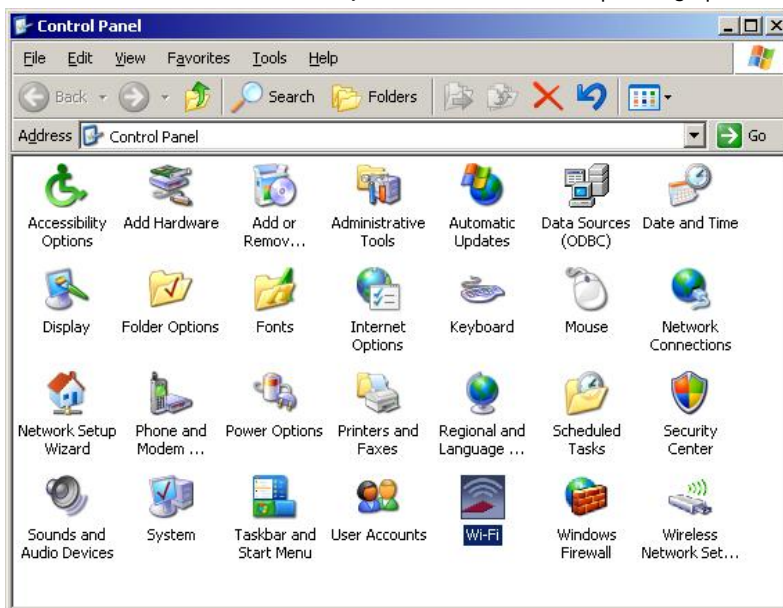

Figure 5.4: Wi-Fi Icon in Control Panel

### 5.7.3.1. Password SCU

Depending on the configuration, it may be necessary to enter a password.



Figure 5.5: Summit Client Utility menu

To do so, click the Admin Login button. An input field appears for the password.



Figure 5.6: Summit Client Utility password input

The standard password is: **SUMMIT** (must be entered in capital letters!) You can find details about the configuration parameters in the SCU online help.

## 5.8. Calibrate / re-calibrate the touch screen

Read chapter 9.4. *Calibrating the Touch screen*.

## 5.9. Protecting the TFT display from the memory effect

The TFT display of the MTC 6 has to be protected from the burning in of a motionless image. An image that has remained motionless for too long can cause irreversible damage to the display.

Define in the power management center of the utilized operating system that the displays of the MTC 6 should be turned off when no user input occurs.

A motionless image can stay on the display for a maximum of 12 hours. After more than 12 hours there is the risk of the memory effect.

## 5.10. Removing the protective film from the display

The front display of the MTC 6 is protected during transport by a transparent film. This film should remain on the front display during assembly to avoid damage to the front display surface.

Only remove the film once all of the assembly work has been completed.



## 5.11. External connectors

Connectors on the rear side of the MTC 6:



Figure 5.7: External connectors with optional ext. antenna

Detail view:

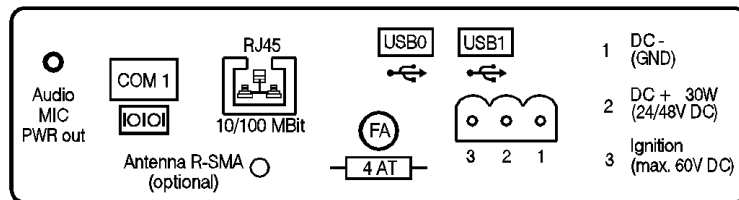

Figure 5.8: External connectors detail view (with ext. antenna)

### 5.11.1. DC voltage supply connector

Version: Phoenix Combicon, 3-pin.

External view:

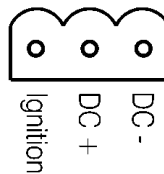

Figure 5.9: Exterior view of the DC power supply connector

**Explanation:**

Ignition on means that a control signal has to be routed to this connection (e.g., ignition of a vehicle), that matches the supply voltage level and is able to supply at least 1 W to the MTC 6.

The signal reference is DC-.

5.11.2. Power supply cables

Use only original power supply cables from Advantech-DLoG  
Advantech-DLoG power cables meet the specific requirements for low-temperature flexibility, UV resistance, oil resistance, etc.

**NOTICE:**  
Property damage

- Use only original power supply cables from Advantech-DLoG.

If other power supply cables are used:

- The user/operator of the industrial PC is solely responsible for the resulting damage.
- All warranties by Advantech-DLoG are voided.

5.11.3. MTC 6 power supply cable

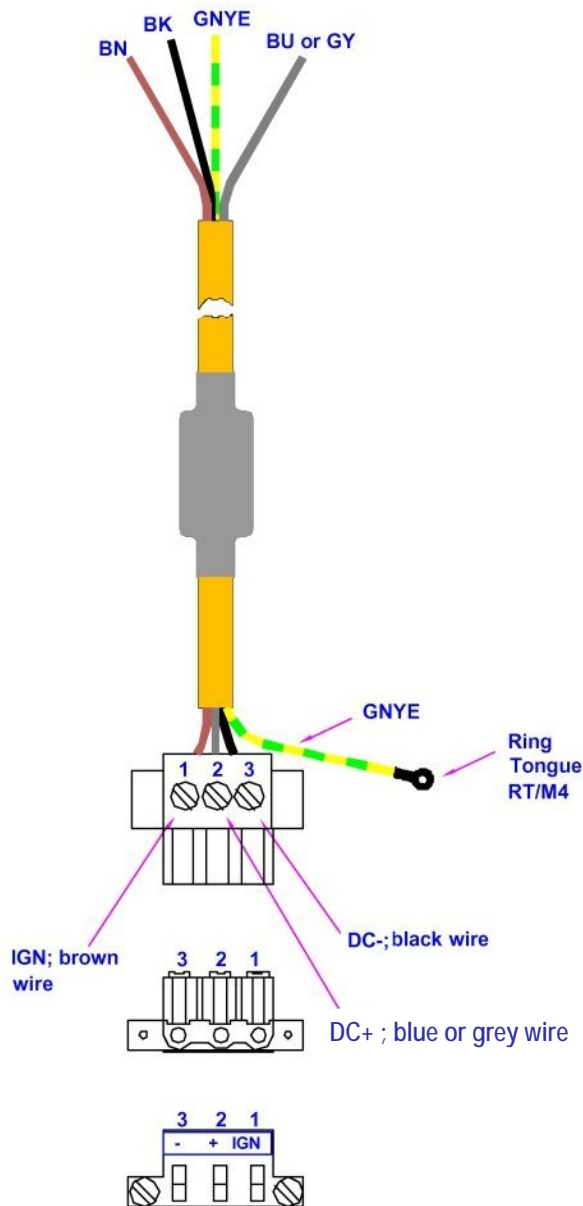

Figure 5.10: Power supply cable

## 5.12. Service USB interface

A service USB interface is arranged under the antenna cap of the MTC 6.

Please observe the following information: Chapter 7.8 *Antenna cap and service USB interface*

**NOTICE:**  
Property damage

It's essential to switch-off the MTC 6 before opening the antenna cap.

The service USB interface may only be used for maintenance purposes, e.g. to load software updates.

The antenna cap/service USB interface may only remain open for the duration of the service work. It may only be opened and closed by qualified technical personnel. No objects or fluids may be introduced into the MTC 6 while the antenna cap and the USB interface are open.

Only when the antenna cap/service USB interface is properly closed again may operation be resumed; protection class is then ensured again.

If the MTC 6 is operated with the antenna cap/service USB interface open for a longer period of time than required for service tasks, any warranty claim against Advantech-DLoG for the unit will be void.



Figure 5.11: Service USB under the antenna cap

### 5.13. Connecting external devices

The MTC 6 must be disconnected from the power supply:

- before external devices (e.g., scanner, keyboard) are connected or disconnected
- and before the MTC 6 can be connected to a network.

<b>NOTICE:</b> Property damage	Make sure that external peripheral devices with their own power supply are switched on at the <u>same time</u> as the MTC 6 or <u>after</u> you start the MTC 6. If this is not possible, please ensure that the MTC 6 is adequately protected from power leakage caused by an external device.  Only power up the MTC 6 when all devices have been connected and the MTC 6 has been closed correctly (remember the cable cover!). Otherwise, you may damage the MTC 6.
-----------------------------------	---

### 5.14. Powering up the MTC 6

Only power up the MTC 6 after connecting all of the devices.

The MTC 6 is powered up by connecting it to an appropriate power supply and then, depending on the version of the device, either using the <Power>-key or the ignition signal.

<b>NOTICE:</b> Property damage	Make sure there is a suitable disconnecting device such as a power switch or circuit breaker in the power supply circuit.
-----------------------------------	---



Figure 5.12: MTC 6 <Power>-key

## 6. Accessories (Options)

### 6.1. Keyboard

On the MTC 6 any USB keyboard can be connected.

#### SMALL keyboard

A mountable SMALL keyboard with protection class IP 65 (German/English/French) is available for the MTC 6.



Figure 6.1: SMALL keyboard

#### 24-key keypad

A 24-key keypad which can be mounted onto the device, with a protection class IP 65 is available for the MTC 6.



Figure 6.2: 24-key keypad

### 6.2. Mouse

Any USB mouse or any mouse with RS-232 port can be connected to the MTC 6.

### 6.3. Microphone (Voice Kit)

The optional MTC 6 Voice Kit includes a handset microphone incl. a speaker system and mounting bracket.



Figure 6.3: Voice Kit microphone (optional)

## 6.4. External CD/DVD-ROM drive

An external CD/DVD-ROM drive is available for the MTC 6. This is connected via the USB interface.

<b>NOTICE:</b> Property damage	<p>When connecting an external USB CD/DVD-ROM drive which has its own external power supply the MTC 6 must be disconnected from the power supply. The CD/DVD-ROM must be powered up simultaneously or after the MTC 6 as otherwise this can cause start-up problems, malfunctions, or even the destruction of the device.</p> <p>Please note: Not every device classified as a USB CD/DVD-ROM is a proper USB CD/DVD-ROM drive. Only use devices approved by Advantech-DLoG to ensure the device is fully compatible.</p>
-----------------------------------	---

The CD/DVD-ROM drive is bootable once it has been properly installed. To boot from a CD/DVD-ROM, insert a bootable CD/DVD and start the system.

	In the BIOS USB CDROM must be entered as a boot device.
---	---

## 6.5. USB stick

You can connect a USB stick to the MTC 6 with a USB-A connector.

## 6.6. USB recovery stick

With the optional Advantech-DLoG recovery stick, images can be backed up and restored on the MTC 6 if necessary (backup & recovery). Please consult your Advantech-DLoG sales representative if necessary.

## 6.7. Scanners

You can connect scanners to either the USB port or the serial port. If connected to COM1, the scanner can be powered through the port (optional, 5 V).

Be sure to only use scanners that have been approved by Advantech-DLoG.

### 6.7.1. Scanner bracket

Scanner brackets are available for the MTC 6 for current scanners (optional). Scanner brackets can be fastened to the left or right of the unit.

## 6.8. WLAN card (PCIe MiniCard)

The WLAN card is integrated into the unit by Advantech-DLoG at the factory (internal PCIe MiniCard slot).

In general, only drivers for WLAN cards approved by Advantech-DLoG can be integrated into operating system images.

## 7. Mounting

### 7.1. Pay careful attention to mounting instructions

Please follow the mounting instructions included with assembly kit when installing your MTC 6.

Please make sure that you retain the instructions. Pay careful attention to the *Basic safety guidelines* included in the beginning of this manual.



**WARNING:**

The unit could fall during transit or installation/mounting and cause injury. Always ensure that there are two persons available when installing or removing the device.

### 7.2. Cooling through the supply of fresh air

The MTC 6 employs a passive cooling concept whereby the waste heat generated inside the device is emitted from the surface of the housing. For this system to function properly, sufficient fresh air circulation is required.

Never install the system in a closed environment where the cooling air is unable to dissipate accumulated heat to the outside.

**NOTICE:**  
Property damage

If the MTC 6 does not have access to fresh cooling air, it may result in overheating and severe damage to the unit. The maximum permissible ambient temperature for the entire system needs to be taken into account for the concrete application area.

### 7.3. Power supply

The MTC 6 is equipped with a galvanically separated, integrated DC power supply.

Power is connected to the underside of the unit using a Phoenix Contact plug. There is no power switch.

**NOTICE:**  
Property damage

The MTC 6 must only be connected to a SELV circuit. The SELV circuit is a secondary circuit that is designed and protected so that its voltages will not exceed a safe value both when operating correctly or if a single error occurs.

Ensure that there is a suitable disconnecting device such as a power switch or circuit breaker in the power supply circuit. Ensure that the disconnecting device isolates all supply voltage lines.

The DC+ connecting cable must be protected by a fuse (30 AT max.).

The ignition connecting cable must be protected by a fuse of the following type: 5x20 mm T 125 mA L / 250 V, for example, a Wickmann 195-125 mA / 250 V.

**Use only original power supply cables from Advantech-DLoG**

Advantech-DLoG power cables meet the specific requirements for low-temperature flexibility, UV resistance, oil resistance, etc.



- Make sure that the connecting cables are laid without kinks and are protected.
- Use only original power supply cables from Advantech-DLoG.

If other power supply cables are used:

- The user/operator of the industrial PC is solely responsible for the resulting damage.
- All warranties by Advantech-DLoG are voided.



## 7.4. Vehicle applications (such as forklifts)

Pay special attention to the various electrical potentials when installing the unit on a vehicle (such as a forklift).

On the MTC 6, the logic ground and the shield ground are firmly linked.

The “logic ground” is the earth line (GND) for all of the internal electrical components, such as the display and the CPU.

The cable shielding and the housing are connected to the “shield ground”.

**NOTICE:** Pay attention to the following warnings!  
Property damage

- Some forklifts have a chassis that is connected to DC+. Therefore, the MTC 6 chassis is also connected to DC+. However, if you use peripheral devices that supply DC– to the MTC 6 via an interconnector (such as a DC– serial port), this will cause a short circuit. This will inevitably lead to malfunctions or even a total system failure.
- In DC-powered devices, always attach ring tongues on the supply voltage cable to the ground bolt situated on the connector bay.

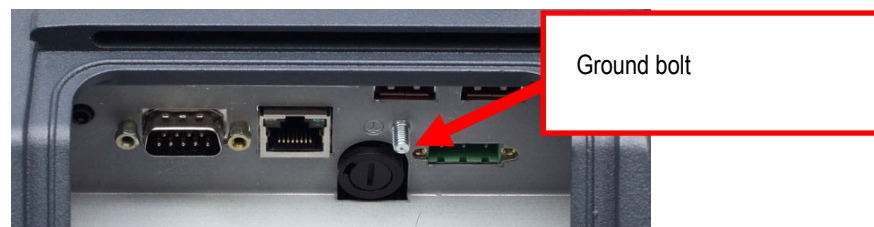

Figure 7.1: Position of the ground bolt

- The other end of the yellow-green supply voltage cable should be connected to the vehicle’s chassis.
- Make sure that the MTC 6’s connecting cable is attached as close to the battery as possible. Connecting the MTC 6 to large electrical loads, such as converters for the forklift motor may result in random restarts, malfunctions and/or irreparable damage to the device.
- If you want to connect devices fed by other power sources to the MTC 6, such as printers and so on, be sure to power up the peripheral devices at the same time or after the MTC 6. Otherwise, you may encounter start-up problems, malfunctions or even irreparable damage to the device.

### 7.4.1. Position of the MTC 6 in the vehicle

In the vehicle, the driver’s field of view must be kept free.

If a keyboard and scanner should be installed on the MTC 6, please plan sufficient space.

No part of the MTC 6 system may project beyond the vehicle.

## 7.5. Cable cover (splash guard)

**NOTICE:** For safety reasons, the supplied cable cover for the external ports must be installed prior to  
**Property damage** using the MTC 6.

### Protection class

In order to comply with the certified protection class, please use the optionally available assembly kit from Advantech-DLoG. Please observe the installation instructions included with this assembly kit.

## 7.6. Strain relief

After the MTC 6 and bracket are fastened:

- Prepare the strain relief.
- Install the cables loosely on the strain relief rail.
- As far as possible, route cables leading to or away from the unit next to one another without crossing.

Completing:

- Fasten the cables to the strain relief rail.
- Be sure that the cables are fastened precisely at the positions at which the cable openings in the cable cover are located.

## 7.7. Minimum distance to WLAN antenna



In order to avoid exceeding the limits determined by the FCC for exposure to radio waves, you (and other people in your vicinity) should maintain a minimum distance of 20 cm from the antenna integrated into the computer. Please note this while mounting industrial computers with WLAN antennas.

## 7.8. Antenna cap and service USB interface

Under the antenna cap or protective cap of the MTC 6 there is a Service USB interface.



Figure 7.2: Antenna cap MTC 6

To access this Service USB interface, you need to remove the antenna cap from the unit.

Switch-off the MTC 6 before opening the antenna cap!

**NOTICE:**  
Property damage

Incorrect or improper removal and fastening of the antenna cap can impair the function of the entire MTC 6 system and in particular the WLAN functionality! Incorrect or improper changes made to the MTC 6 will invalidate any warranty provided by Advantech-DLoG.



Figure 7.3: Opened antenna cap

Unfasten antenna cap from unit and refasten it:

1. Switch-off the MTC 6 before opening the antenna cap!
2. Unscrew the two screws from the antenna cap with an Allen key (size 3 mm).
3. Lift the antenna cap carefully to avoid pulling on the antenna connection cables (max. 2 to 3 cm).
4. Keep hold of the antenna cap, making sure that no pulling tension is exerted on the antenna connection cables.
5. The Service USB interface is now accessible.

**CAUTION:** One end of the antenna connection cables is attached to the antenna cap, the other end to the internal WLAN unit of the MTC 6. The cables must not be pulled out of the MTC 6 too far and become detached from the WLAN unit! This might damage the WLAN unit or other components of the device.

6. Place the antenna cap back onto the MTC 6.
7. Take care not to trap the antenna connection cables when doing this.  
The antenna cap seal must not be damaged; it must be seated correctly in the groove.
8. Reinsert and tighten the two screws of the antenna cap (1 Nm torque).

## 8. Operation

### 8.1. Touch Screen

Operation of the resistive touch screen is recommended with:

- clean, dry fingers
- clean, dry, soft gloves
- suitable touch stylus (plastic or wood, rounded tip)

To protect the Touch screen:

- Keep the panel surface clean.
- Prevent any kind of adhesive applied on the surface.
- Avoid high voltage and/or static charge.
- Touch screens may not be operated with ball-point pens or writing utensils, tools of any kind (e.g. screwdrivers) or with sharp objects (knives, scalpels, etc).
- Touch the panel with your finger or stylus only to assure normal operation. Any sharp edged or hard objects are prohibited.
- Operate the panel in a steady environment. Abrupt variation on temperature and humidity may cause malfunction of the panel.
- Avoid applying excessive activation force or sudden impact on the panel surface.

### 8.2. Software Keyboard

The DLoG Software Keyboard brings the complete standard keyboard with function keys and numeric pad directly to your MTC 6 screen – with easy touch operation. Any entries made, for example, letters and numbers, are passed to the application program currently active. Example Software keyboard:



Figure 8.1: Software Keyboard

If the software keyboard was ordered together with the MTC 6, then the program will have been fully pre-licensed by the Advantech-DLoG production department. For subsequent installation, an installation program is available.



Find detailed information in the user manual for the Software keyboard in our Download Center ([www.advantech-dlog.com](http://www.advantech-dlog.com)).

### 8.3. Front keys and LEDs

The MTC 6 has the following front keys and LEDs:



Figure 8.2: MTC 6 front keys and LEDs

#### 8.3.1. <Power> key and brightness control



<Power>-key: Start/Shutdown MTC 6

Manual brightness control: brighter

Manual brightness control: darker

#### 8.3.2. LEDs



Temp (red) LED indicates an excessively high or low temperature inside the unit

Activity (green) LED indicates access of the flash drive

Power (green) LED indicates an available internal power supply

### 8.3.3. Special keys

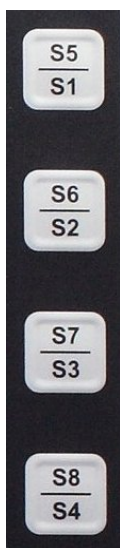

Special keys <S1> to <S8>

The special keys can be configured with the “DLoG Config program” (select the Front keys menu).



### 8.3.4. <Shift>-key



Switch the keys <S1>, <S2>, <S3> and <S4> to <S5>, <S6>, <S7> and <S8>

The lucent LED indicates an activated <Shift>-key.

## 8.4. Operating states

Status of internal LEDs		MTC 6 status
Power (green)	Temp (red)	
		

OFF	OFF	Initial state, idle time - waiting for a new ignition signal after switch-off; no power supply
OFF	FLASHING	Temperature sensor malfunctioning
FLASHING	OFF	MTC 6 is in stand by mode (S3).
OFF	ON	The computer will not start until the temperature inside the unit is between -30 °C and +62 °C again.
ON	OFF	Computer is starting up; normal operational state; shutdown delay time is running
ON	ON	Temp. < -30 °C or Temp. > 70 °C
ON	FLASHING	Temperature sensor malfunctioning; automatic switch-off software configuration

## 9. Touch screen

### 9.1. Construction type and resistance

- Analog-resistive touch technology
- Construction: Film-Glass (FG)
- Hardness of surface: 3H (ASTM D3363)
- Resistance : >10 million actuations

### 9.2. Operation

The finger or a suitable stylus can be used for operation. For more details, please see Chapter 8 *Operation*.

### 9.3. Cleaning

- Use neutral detergent or isopropyl alcohol on a clean soft cloth to clean the panel surface.
- Prevent using any kind of chemical solvent, acidic or alkali solution.

### 9.4. Calibrating the Touch screen

The touch screens of all MTC 6 devices that come delivered with an operating system (Windows or Linux) are already calibrated. If the touch screen needs to be recalibrated, please note the following information.

#### UPDD or TSHARC touch driver

Depending on the CPU and operating system, different touch drivers are used with the MTC 6 series:

- UPDD
- or TSHARC

Both drivers use utility programs to calibrate the touch screen.

To check what driver is being used on your MTC 6:

- Go to Start -> All Programs. Here you will find either a UPDD or a TSHARC Control Panel folder.
- Use the relevant tool to calibrate (more on this on the following pages).



## Calibrating with UPDD

- Under Start -> All Programs, open the UPDD folder.
- Click on Calibrate to start the calibration process.
- Click on Settings if you would like to change the parameters of the touch settings.



The calibration will give the most precise result with the following settings. These settings are pre-set in Advantech-DLoG Images.

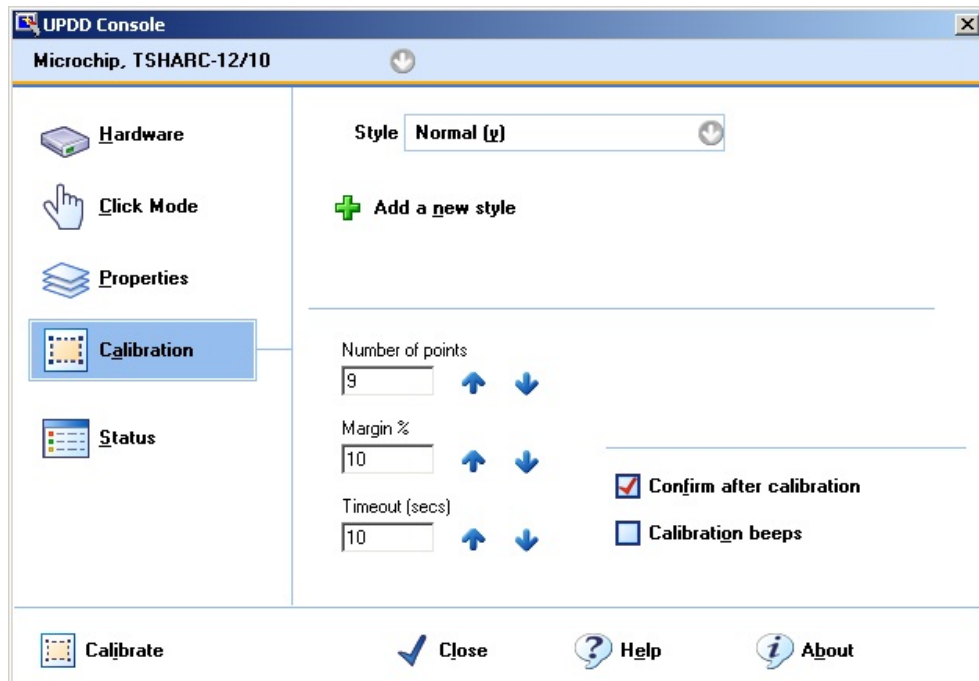

Figure 9.1: Touch-screen recalibration using UPDD

- In the parameter Number of points, please select "9".
- For parameter Margin, you have to enter "10%". This clearance is a prerequisite in order for the touch screen to function precisely.
- Start the calibration process using Calibrate.
- The MTC 6 does not need to be restarted after calibration.

### Calibrating with TSHARC

- Under Start -> All Programs click on the TSHARC Control Panel folder.
- Click on Calibrate, then on the Calibration tab.

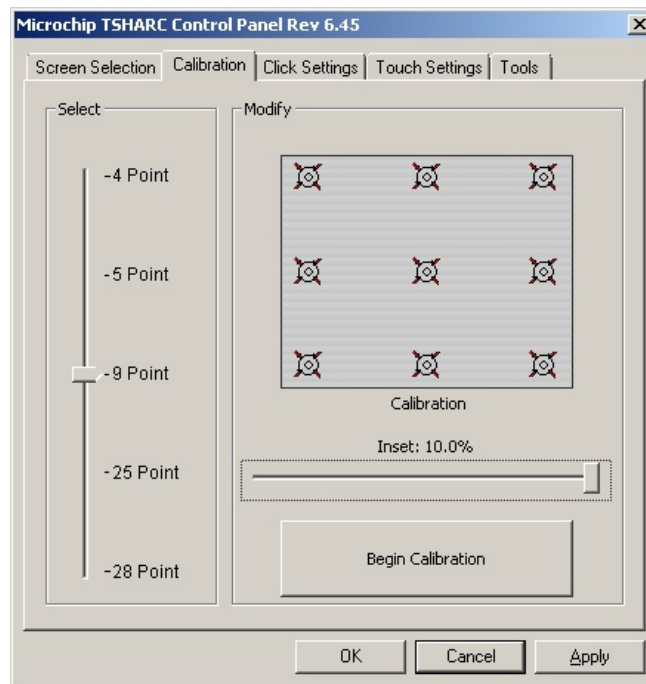

Figure 9.2: Touch-screen recalibration using TSHARC

Please apply the following parameters precisely to calibrate the touch screen:

- In the parameter Select, please select "9". You do this because the 9 point calibration provides the most precise result.
- For parameter Inset, you have to enter "10%". This clearance is a prerequisite in order for the touch screen to function precisely
- Start the calibration process using **Begin Calibration**.

The MTC 6 does not need to be restarted after calibration.

## 10. Serial port

The MTC 6 is equipped with an externally accessible serial interface COM1. Resources for the serial port are pre-defined in the system architecture and automatically managed by the BIOS.

### 10.1. COM1 as a power supply (optional)

The COM1 port can optionally supply externally connected equipment with +5 V of power.

The voltages are protected by internal fuses which limit the total consumed current to 1.1 A at 5 V.

Depending on the specific system configuration, the maximum current consumption may be significantly lower.

### 10.2. Serial port printers

Printers with a serial port can be connected to the MTC 6.

### 10.3. Serial port barcode scanners

To activate the integrated scanner software wedge under MS<sup>®</sup> Windows<sup>®</sup> XP Embedded:

1. Open the Start menu and navigate to Settings | Control Panel | Accessibility.
2. Select the General tab.
3. Select Support accessibility options .
4. Click Settings.
5. Configure the desired COM1 port and BAUDrate.
6. Confirm the change with OK.
7. Click OK again for the changes to take effect.

**NOTICE:**  
Property damage

Please note that you have to configure the scanner correctly to RS-232 and the above set BAUDrate following the scanner manufacturer's guidelines. Otherwise the software wedge will not function properly.

### 10.4. Tips & tricks

Note that according to the EIA-232-E specification, the maximum cable length is 15 m at 19,200 bps.

Malfunctions in the RS-232 connections are frequently caused by ground loops. If both end devices establish a ground connection via RS-232 but do not share the same ground potential in their power supply circuits, then compensation currents may result. This is particularly noticeable with long cables.

These compensation currents, which are also present at the ground point of the RS-232 connection, may significantly degrade signal quality and effectively stop the data flow. In challenging environments, electrically-isolated connections (via external converters) or differential systems (RS-422/485 port) are strongly recommended.

## 11. Internal devices

### 11.1. Network adapter (10/100/1000)

The MTC 6 is equipped with a 10/100/1000 Mbit network adapter. This adapter can be accessed via the bottom of the device and offers an RJ45 connection jack.

The RJ45 connection port features two integrated status LEDs.

They display the following messages.

#### 11.1.1. MTC 6 Intel

Left LED (green)

LED off: not connected

LED on: connected

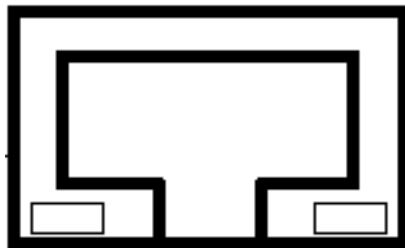

RJ45 network port

Right LED (orange):

LED off: no activity

LED flashes: activity

Figure 11.1: RJ45 network port of MTC 6 Intel

#### 11.1.2. MTC 6 AMD

Left LED (green)

LED off: not connected

LED flashes; activity

LED on: connected

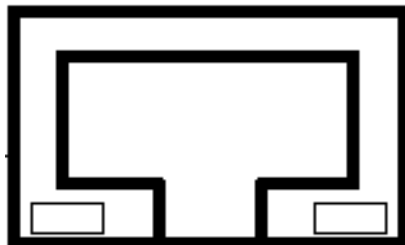

RJ45 network port

Right LED has no function.

Figure 11.2: RJ45 network port of MTC 6 AMD

#### 11.1.3. Problems with data transmission via LAN/Ethernet

If problems occur during data transmission over LAN/Ethernet (e.g. data is lost or not detected), the cause of these problems may be a cable which is too long.

Depending on the cable layout and interference from the environment, it may be impossible to use the cable length of 100 m given in the specification (IEEE 802.3 standard).

The solution here is the use of a shorter cable.

## 11.2. Automatic switch-off

The MTC 6 is equipped with an automatic switch-off module.

### Modes of operation

If wired up accordingly, the MTC 6 conveniently switches off together with the vehicle's ignition.

As disconnecting the power supply during operation can lead to data loss, the operating system needs to be shut down normally using the appropriate hardware and software installed on the system when the ignition is switched off.

The MTC 6 is connected to the vehicle with three supply cables. DC+ und DC- are directly connected to the power supply of the vehicle, the connection is of course run through fuses.

Therefore make sure that the cables are connected directly to the battery and not to high-interference supply lines (for example, motor supply) or to supply lines already used by other consumers.

The supply voltage connected is then linked to the MTC 6's ignition input via a switch, for example, the key switch of the ignition (also with a fuse).

### 11.2.1. Automatic switch-off process

When the ignition is switched on, the MTC 6 is supplied with power and begins checking its internal temperature and automatic switch-off function.

Once the ambient conditions have been verified as acceptable, the MTC 6 starts the operating system just like normal.

During the first three minutes of the start-up phase, none of the ambient conditions, such as the internal temperature or the *Ignition* input status, are checked. This allows the operating system and the operating software for the automatic switch-off module to fully load without interruption.

Following this three-minute period, the internal temperature of the unit and the status of the *Ignition* input are checked continuously.

If the inner temperature of the MTC 6 reaches a critical range, the operating system is shut down normally and the computer remains switched off until the temperature is back in the permitted range.

If the *Ignition* input is switched to earth potential or a potential-free source during normal operation, the unit switches to shutdown delay time.

In this state, the device continues to operate normally until the delay time (for example, 15 minutes) has elapsed.

- If the ignition is triggered again during this time, the MTC 6 resumes normal operation.
- If, however, the delay time elapses, the operating system is shut down normally by the Advantech-DLoG operating software and the unit is automatically switched off (for example, after three minutes, or after a signal from the operating software).

### 11.2.2. Configuration with DLoG Config program

The DLoG Config program must be installed for the automatic switch-off module to function correctly.

If the DLoG Config has not been started, the MTC 6 will carry out a hard shutdown once the delay time and shutdown time set by the hardware (e.g. via MPCCOM.EXE) has elapsed. In this case, the operating system is not shut down normally before the power is switched off. The current application is unable to save its data, and the file system becomes increasingly unstable and inconsistent.

If the DLoG Config has been started, the program can recognize when the operating system needs to be shut down. Firstly, the Windows message "WM\_QUERYENDSESSION" is sent to all running applications to inform them of the impending shutdown.

Now every application has to respond within the time that is set in the registry (see the DLoG Config manual). If a response is not sent in the specified time, the application is forced to quit.

If there are any open programs with unsaved changes, it may not be possible to automatically quit them (for example, an unsaved document in WORDPAD.EXE, a program supplied with Windows). In this case WORDPAD.EXE responds to the Windows message "WM\_QUERYENDSESSION" with a user query to confirm if the current file is to be saved. Applications that can be quit with the key combination <ALT> and <F4> (that is, without a final user query) generally send the required response to the "WM\_QUERYENDSESSION" message and are not shutdown "hard".

To ensure that vital data is always saved correctly, applications need to be able to properly respond to the "WM\_QUERYENDSESSION" message, that is, without user queries and within the set time period.

Further information to the DLoG Config program can be found in the corresponding manual.

## 12. Troubleshooting

### 12.1. Data transmission via LAN/Ethernet

If problems occur during data transmission over LAN/Ethernet (e.g. data is lost or not detected), the cause of these problems may be a cable which is too long.

Depending on the cable layout and interference from the environment, it may be impossible to use the cable length of 100 m given in the specification (IEEE 802.3 standard).

The solution here is the use of a shorter cable.

### 12.2. Images for Intel and AMD devices are not compatible

Images that were created for MTC 6 devices with an Intel processor cannot be used on AMD devices, and vice versa, as they are incompatible.

If the wrong image is used, a blue screen appears with the following technical information: 0X0000007B.

### 12.3. MTC 6/12 AMD: switch off / restart

In the event that ambient temperatures exceed 40 °C, the processor comes under high strain or output is extracted externally via peripheral interfaces (USB, serial), the MTC 6/12-AMD may switch off or restart under unfavorable conditions.

Corrective action: Ensure sufficient cooling. Supply the connected external peripheral devices from other external sources.

## 13.Maintenance



**WARNING:** Danger due to electric shock when cleaning and maintaining the device.

To avoid electric shock, turn the MTC 6 off and disconnect it from the power supply before cleaning or maintaining it.

### 13.1. Cleaning the housing

- The housing of the MTC 6 is best cleaned with a damp cloth.
- Do not use compressed air, a high-pressure cleaner or vacuum cleaner, as this can damage the surface.
- Using a high-pressure cleaner poses the additional risk of water entering the device and damaging the electronics or display.

### 13.2. Touch screen cleaning

- Use neutral detergent or isopropyl alcohol on a clean soft cloth to clean the panel surface.
- Prevent using any kind of chemical solvent, acidic or alkali solution.



## 14. Common mistakes in usage

### 14.1. Images for Intel and AMD devices are incompatible

- Do not copy images that were created for MTC 6 devices with an Intel processor to AMD devices, and vice versa, as they are incompatible.

### 14.2. Power supply

- Do not connect MTC 6 devices to an AC power supply.
- Observe correct voltage ranges.

### 14.3. Powering up/down

- Please note that the function of the MTC 6's <Power>-key varies depending on how the device is configured.
- Only disconnect the computer from the power supply after the computer has been properly shut down and switched off. Otherwise file errors may occur on the storage device (in operating systems that have no activated write protection filter).

### 14.4. Cable cover

- The supplied cable cover for the external ports must be installed prior to using the MTC 6.
- In order to comply with protection class, please use the optionally available assembly kit from Advantech-DLoG.

### 14.5. Mounting/Installation

- Only use suitable mounting brackets and screws permitted by Advantech-DLoG.
- Ensure that ball-and-socket bases and fastening arms are securely attached.
- Follow the instructions carefully when attaching all outgoing cables to the strain relief rail.
- The WLAN antenna should not be used as a handle when turning the terminal.
- All fastening brackets and mounting parts supplied by Advantech-DLoG are only intended for use in the mounting of terminals and peripheral devices and may not be used for other purposes.
- When mounting peripheral devices, follow the manufacturer's instructions. This is particularly important when welding or drilling supporting parts.
- To avoid any accidents, make sure your field of vision is not restricted in any way when mounting peripheral devices. Observe all accident prevention regulations.

## 14.6. Mobile application on vehicles

- Observe correct voltage ranges.
- Ensure that supply lines are fused correctly.
- Lay the supply cable so that it will not get crushed or frayed.
- Read the labeling on the cable and connect the supply cable with the correct polarity.
- Cut the supply cable as short as possible. This avoids tangled cables and improves the quality of the power supply.
- Observe the vehicle manufacturer's instructions for connecting additional loads, for instance, in conjunction with an emergency shut-off switch.
- Be sure that the connection of the line is as directly as possible to the battery and not to power supply lines with a great deal of interference (e.g. the engine power supply) or otherwise affected by consumers.
- Connect the supply cable to a suitable place. Ensure that the connecting cable has an adequate cross section and ampacity at the connection point.

## 14.7. Using the touch screen

- Keep the panel surface clean.
- Prevent any kind of adhesive applied on the surface.
- Avoid high voltage and/or static charge.
- Touch screens may not be operated with ball-point pens or writing utensils, tools of any kind (e.g. screwdrivers) or with sharp objects (knives, scalpels, etc).
- Touch the panel with your finger or stylus only to assure normal operation. Any sharp edged or hard objects are prohibited.
- Operate the panel in a steady environment. Abrupt variation on temperature and humidity may cause malfunction of the panel.
- Avoid applying excessive activation force or sudden impact on the panel surface.

# 15. Disposal

The Advantech-DLoG general terms and conditions set out the obligations for disposal in accordance with official electronics regulations.

## 16. Return packing slip

Return packing slip (please fill in once per return shipment):

Company	
Street	
Zip code, town	
Contact	
Phone number	

Type(s) of unit(s) returned:

Serial number(s) of the unit(s) returned:

- The units have not been returned, as they are currently being used. However, the following parts are missing:  
 Unit was already damaged on delivery (please enclose a copy of the delivery note)  
 Delivery was incomplete

Missing parts:

--

- The following error occurs when operating the unit:

--

- Separate error report is enclosed

# Index

<Power>-key .....	54
<Shift>-key .....	55
12/24 VDC nominal .....	18
16550A compatible .....	14
1999/5/EF .....	8
24/48 VDC nominal .....	18
24-key keypad .....	45
30 AT fuse .....	47
3H (ASTM D3363) .....	56
9 Point Calibration .....	58
Abbreviations .....	10
Accessories .....	45
Accident prevention regulations .....	3
Activity LED .....	54
Additional loads .....	66
Aluminum-cast housing .....	13
Ambient conditions .....	20, 61
AMD .....	12, 63
AMD APU .....	12
AMIBIOS8 - Flash BIOS .....	12
Ampacity .....	66
Analog touch controller .....	15
Analog-resistive touch technology .....	56
Antenna .....	17
Antenna cap .....	14, 43, 51
Antenna connection cable .....	52
Antenna minimum distance from people .....	51
Antenna solutions .....	37
APU .....	12
Area of application .....	3
Automatic switch-off .....	61
Automatic switch-off configuration .....	35
Automatic switch-off software .....	55
Ball-point pens .....	53, 66
Barcode scanners .....	59
Battery .....	49, 66
Baud .....	14
BIOS .....	12, 59
BIOS POST self test .....	12
Brightness adjustment .....	13
Brightness control .....	54
Bundesnetzagentur .....	37
Burning in a motionless image .....	40
Bussman .....	19
C partition .....	34
Cable .....	63
Cable cover .....	50, 65
Cable labeling .....	66
Cable length .....	63
Cable openings .....	50
Cables .....	65
Cache .....	12
Calibrating the touch screen .....	56
Calibrating with TSHARC .....	58
Calibrating with UPDD .....	57
CD/DVD-ROM drive .....	46
CE Marking .....	7
CFast .....	12
Chassis .....	49
Chipset .....	12
Circuit breaker .....	44, 47
Class 5M3 .....	20
Class A digital device .....	9
Class A products .....	7
Cleaning the housing .....	64
Cleaning the touch screen .....	56
Cleaning/maintaining the device .....	64
Clearance 10% .....	57, 58
Color depth .....	15
COM1 .....	14, 59
COM1 as a power supply .....	59
Common mistakes in usage .....	65
Compensation currents .....	59
Compressed air .....	64
Config program .....	35, 62
Configure the MTC 6 .....	34
Configuring the front keys of the MTC 6 .....	35
Connecting cables .....	49
Connecting/disconnecting external devices .....	44
Connector bay .....	49
Connectors on the rear side .....	41
Converters .....	49
Cooling air .....	47
Cooling concept .....	47
CPU .....	12
Darker .....	54
Data transfer rates .....	37
Data transmission via LAN / Ethernet .....	63
DC power pack .....	18
DC Supply cable .....	42
DC voltage supply connector .....	41
DC+ - connecting cable .....	47
DDR2-Technology .....	12
DDR3-Technology .....	12
Delay time .....	55, 62
Delivery .....	33
Design method .....	2
Device model .....	18
Device type plate .....	11
Dimensions .....	13, 21
Disconnecting device .....	44
Display .....	13, 40
Disposal .....	66
DLoG Config .....	35, 62
Download Center .....	34
EIRP .....	37
Electric shock .....	64
Elu .....	19
Emergency shut-off switch .....	66
EN 954-1 .....	3
ESD safe .....	13
Ethernet .....	15
Ethernet Realtek RTL8111 .....	15
External connectors .....	41
FCC requirements .....	9
FCC user information .....	9
Federal Communications Commission .....	9

File errors .....	65	Microphone .....	16, 45
Flash media .....	12	MIL-STD .....	20
Forklift applications .....	49	Minimum distance from antennas .....	51
Forklift chassis .....	49	Mobile application on vehicles .....	66
Forklift motors .....	49	Model range .....	11
Forklifts .....	49	Models .....	10
Frequency band .....	17, 37	Mouse .....	45
Fresh air circulation .....	47	MPCCOM .....	62
Front key configuration .....	35	MS-Windows Operating systems .....	14
Front keys .....	54, 55	MTC 6/12 AMD .....	63
Fuse .....	19, 47	Multiple power sources .....	49
Gain .....	17	Network adapter .....	60
Galvanically isolated .....	18	Network connection .....	15, 44
Generic mit Gnome .....	14	Network controller .....	15
Gloves .....	53	Network interface .....	15
Ground bolts .....	49	Noise .....	20
Ground loops .....	59	Nominal current .....	18
Ground potential .....	59	Operating resistive touch screens .....	53, 66
Handset microphone .....	16, 45	Operating states .....	55
Hardness .....	56	Operating system .....	14
Heat .....	47	Operating systems .....	14
High-pressure cleaner .....	64	Operating temperature .....	20
Housing .....	13	Operating the touch screen .....	56
Humidity .....	20	Operation .....	53
IEEE 802.11 standard .....	37	Overheating .....	47
IEEE 802.3 Standard .....	63	Packaging .....	33
Ignition .....	41, 61	Password SCU .....	39
Ignition connecting cable .....	47	PCIe MiniCard slot .....	46
Ignition input .....	61	Peripheral devices .....	49
Ignition signal .....	44, 55	Phoenix Combicon, 3-pin .....	41
Images for Intel and AMD .....	63, 65	Phoenix Contact plug .....	47
Impedance .....	17	Polarization .....	17
Inset 10% .....	58	Power consumption .....	19
Integrated antenna .....	17	Power key .....	44
Integrated speaker .....	16	Power LED .....	54
Intel .....	12, 63	Power supply .....	18, 47, 65
Interconnector .....	49	Power supply cables .....	42
Internal devices .....	60	Power supply fuses .....	19
Internal temperature .....	61	Powering down .....	65
IP 65 .....	13	Powering up .....	44
IP 66 .....	13	Powering up/down .....	65
IP 67 .....	13	Printers .....	49, 59
IT technical staff .....	38	Protective cap .....	51
Keep this manual .....	1	Protective film .....	40
Key switch of the ignition .....	61	Qualified personnel .....	1
Keyboard .....	44, 45, 53	Radio frequency exposure .....	9
LAN/Ethernet .....	63	Radio networks .....	36
Land vehicles .....	20	Radio performance .....	36
Large electrical loads .....	49	RAM .....	12
LCD interface .....	15	Real-time clock .....	12
LEDs .....	54	Recalibrated .....	56
Life-support systems .....	3	Recovery stick .....	46
Limit values for exposure to radio waves .....	51	RegTP .....	37
Linux .....	14	Relative humidity .....	20
Linux operating manual .....	34	Remote WLAN antenna .....	17
Littelfuse .....	19	Resistance .....	56
Logic ground .....	49	Resolution .....	15
Maintenance .....	64	Resources for the serial port .....	59
Manual brightness control .....	54	Return packing slip .....	67
Mechanical .....	13	Returning your device .....	33
Mechanical vibration and shock-resistance .....	20	Ring tongues .....	49