

Sensitivity Wavelength Range: InGaAs 800-2600nm / Si 250-1100nm

The MTPD2601SIW-100 from Marktech, a high sensitivity and high reliability product series, is ideally suited for applications requiring a wide spectral bandwidth. Custom packaging for this is also available.

FEATURES

- > High Speed Response
- > TO-39 Hermetically Sealed Package
- > Active Area of 1.0mm Φ / High Sensitivity
- > Spectral Range Si: 250-1100 InGaAs: 800-2600nm

APPLICATIONS

- > High Speed Optical Communications
- > Industrial Controls
- > Gas/Water Analysis
- > LIDAR
- > Medical



Absolute Maximum Ratings (Ta=25°C)



ITEMS	SYMBOL	RATINGS	UNIT
Active Area	Φ	1.0	mm
Operating Temperature Range	Topr	-40 to +85	°C
Storage Temperature Range	Tstg	-40 to +125	°C

InGaAs Electrical & Optical Characteristics (Ta = 25°C)

ITEMS	SYMBOL	CONDITIONS	MIN	TYP	MAX	UNIT
Breakdown Voltage	VR	IR=100uA	--	--	1	V
Sensitivity Range	λ	VR=0V	800	--	2600	nm
Dark Current	ID	VR=0V	--	80	--	nA
Dark Current	ID	VR=1V	--	100	--	uA
Capacitance	C	VR=0V	--	3100	--	pF
Capacitance	C	VR=1V	--	500	--	pF
Responsivity	R	λ =2400nm	--	1.24	--	A/W
Shunt Resistance	RS	VR=10mV	--	0.5	--	k Ω
Quantum Efficiency	QE	λ =1840nm	--	72	--	%

Si Electrical & Optical Characteristics (Ta = 25°C)

ITEMS	SYMBOL	CONDITIONS	MIN	TYP	MAX	UNIT
Breakdown Voltage	VR	IR=10uA	50	--	--	V
Sensitivity Range	λ		250	--	1100	nm
Peak Sensitivity	λ_p		--	950	--	nm
Dark Current	ID	VR=5V	--	--	10	nA
Capacitance	C	@1MHz, VR=0V	--	20	--	pF
Capacitance	C	@1MHz, VR=5V	--	6	8	pF
Responsivity	R	VR=0V, $\lambda=365\text{nm}$	--	0.22	--	A/W
Responsivity	R	VR=0V, $\lambda=633\text{nm}$	--	0.40	--	A/W
Shunt Resistance	RS	VR=10mV	500	800	--	M Ω
Response Time @ 635nm	TR	RL=50 Ω , VR=5V	--	20	--	ns

Package Dimensions

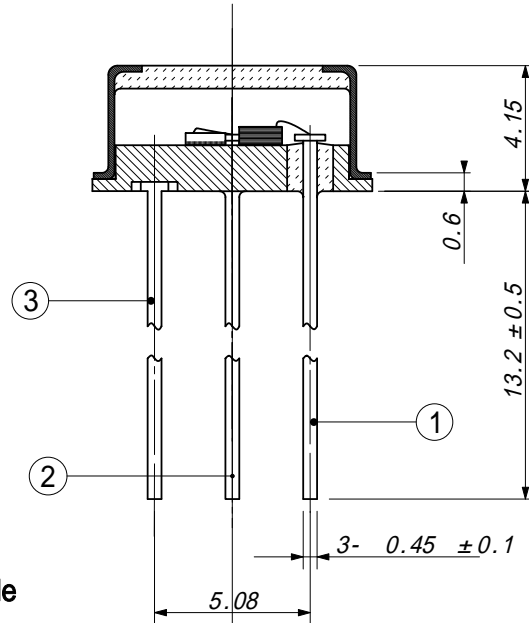
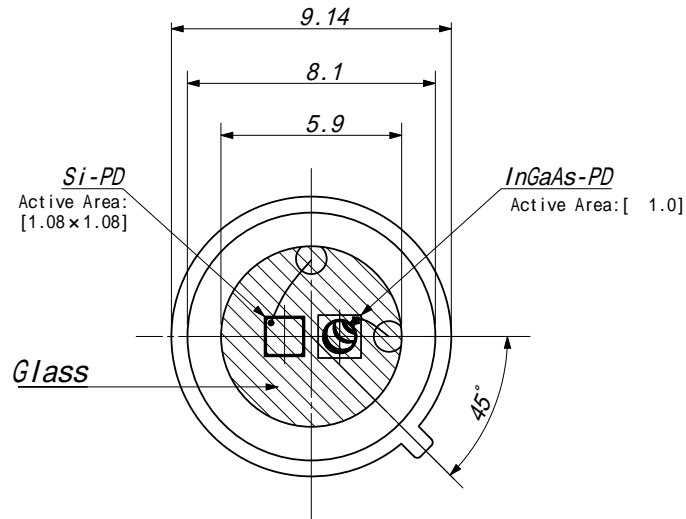

InGaAs PD Anode
Si PD Anode
Cathode com(Case)

InGaAs Spectral Responsivity

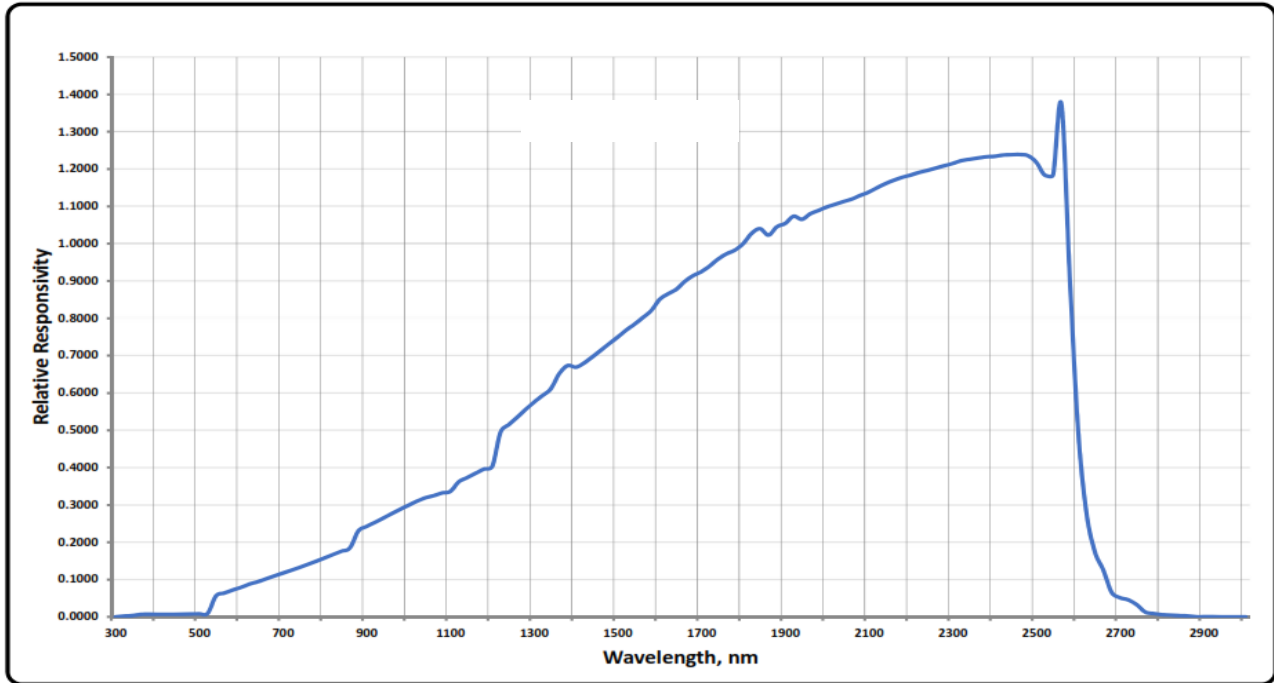

InGaAs Quantum Efficiency

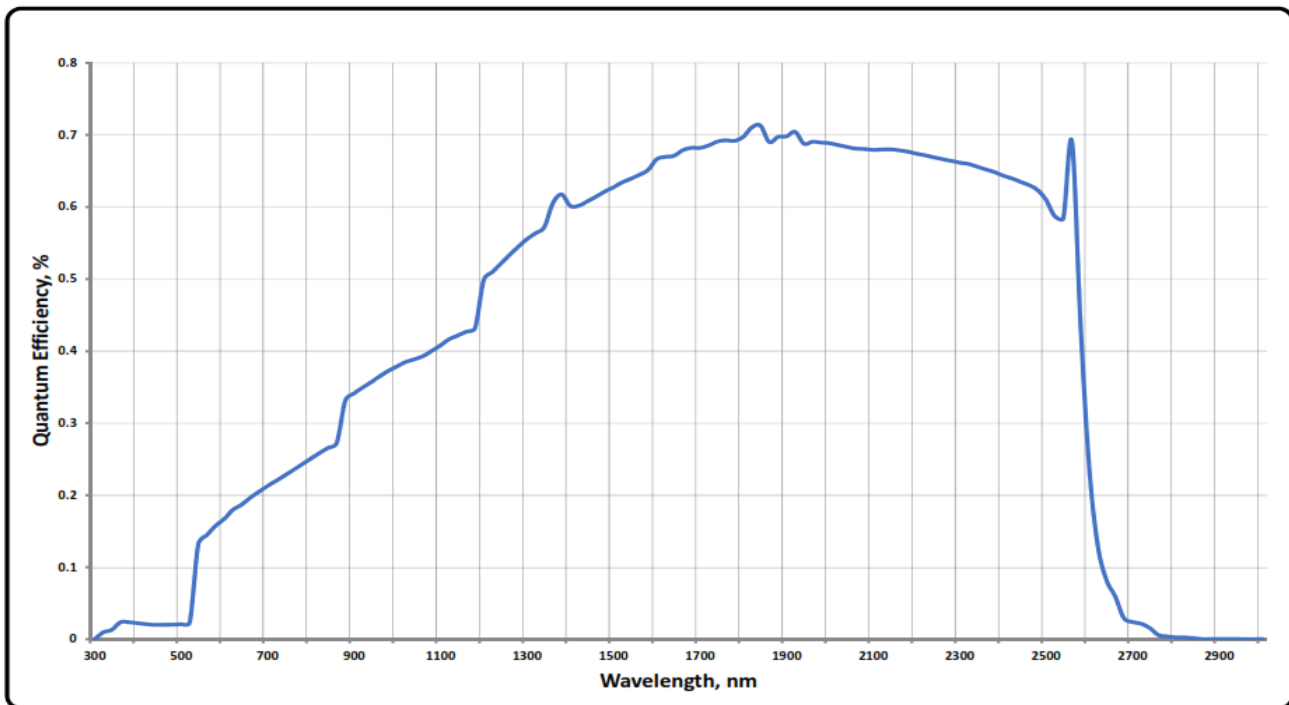

The information contained herein is subject to change without notice.

2023-01-30

InGaAs Dark Current vs Reverse Voltage

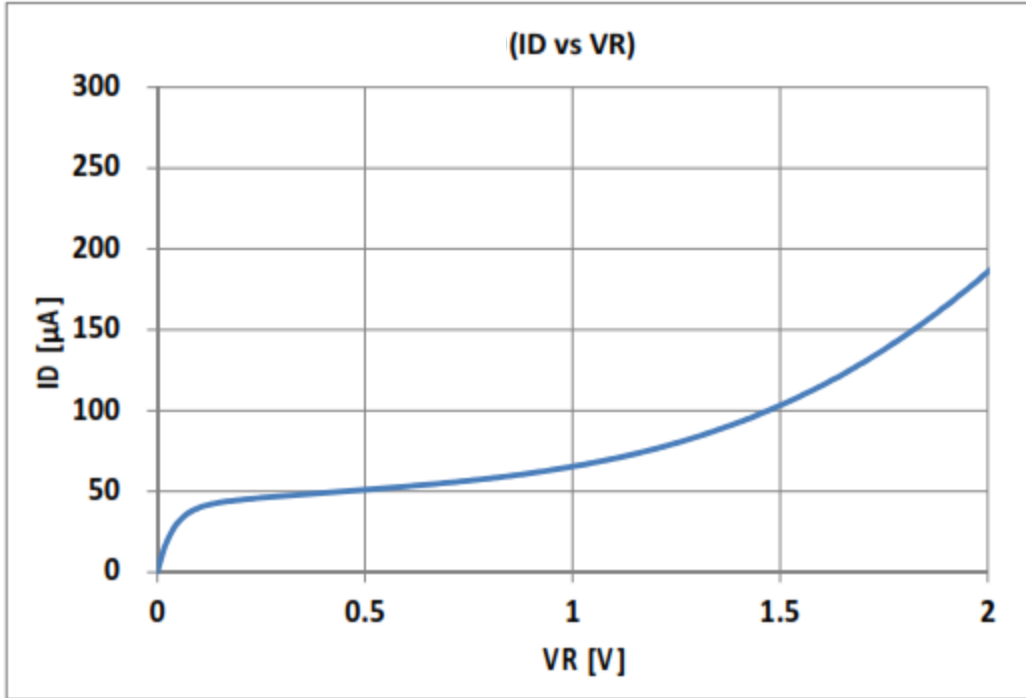

InGaAs Forward Current vs Forward Voltage

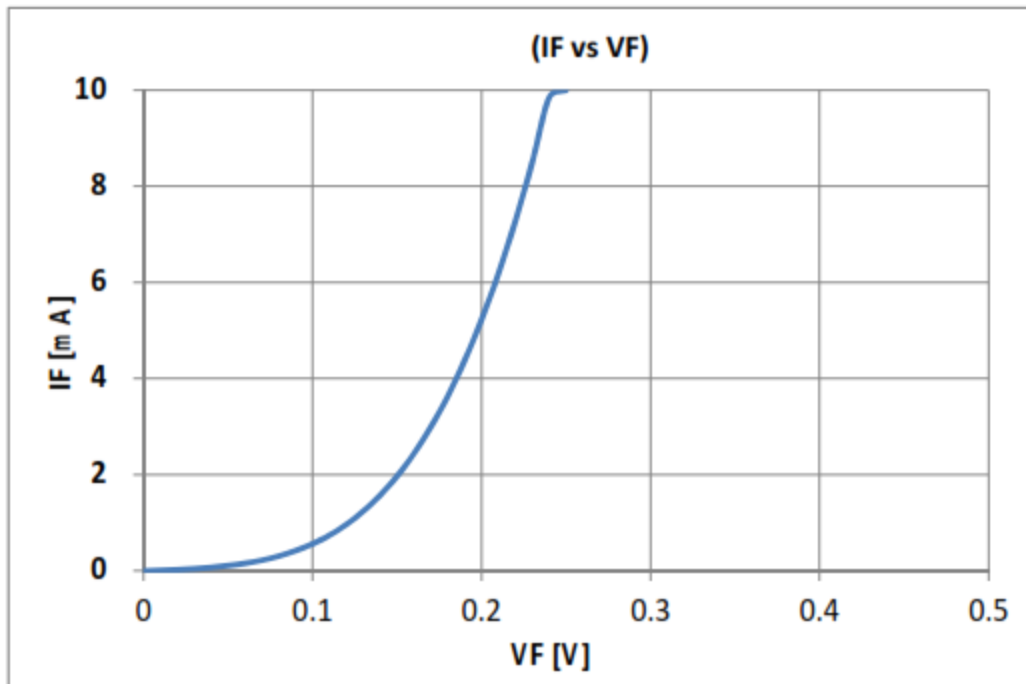

The information contained herein is subject to change without notice.

2023-01-30

Si Capacitance vs Reverse Bias

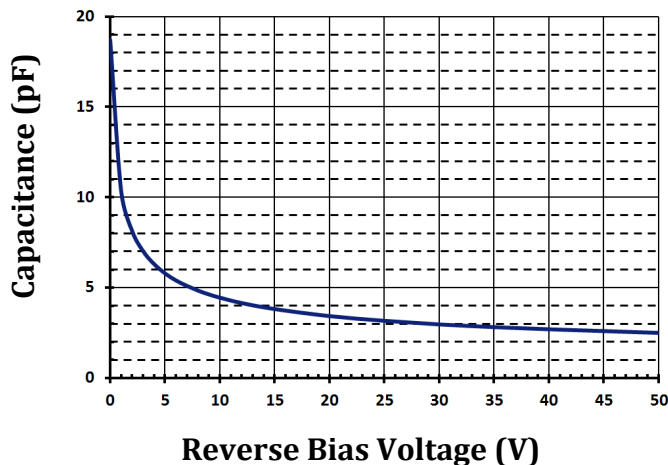

Si Dark Current vs Reverse Bias (23°C)

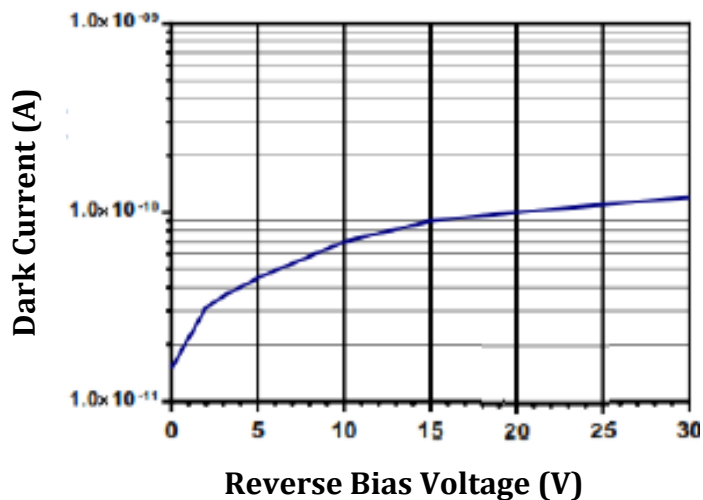

Si Dark Current vs Temperature (Vr=10V)

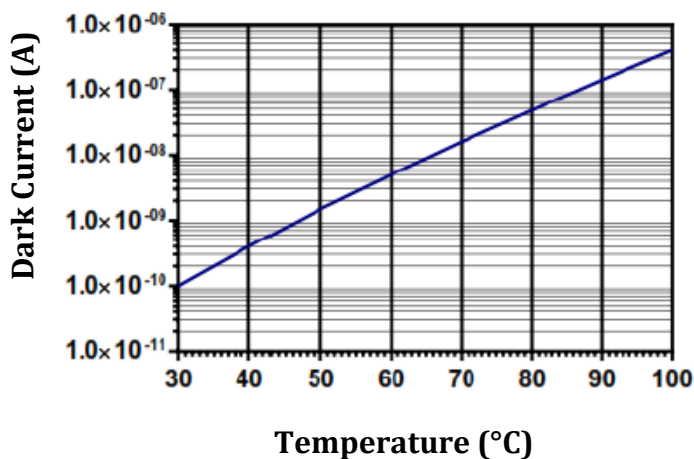

Si Quantum Efficiency (23°C)

