



# MURA1J / MURB1J / MUR160K

## SUPERFAST RECOVERY RECTIFIERS

**Voltage**

**600 V**

**Current**

**1 A**

### Features

- Superfast recovery times-epitaxial construction
- Low forward voltage, high current capability
- Hermetically sealed.
- Low leakage
- High surge capacity
- Plastic package has Underwriters Laboratory Flammability Classification 94V-O utilizing Flame Retardant Epoxy Molding Compound
- Lead free in compliance with EU RoHS 2.0
- Green molding compound as per IEC 61249 standard (SMA)(SMB)

### Mechanical Data

- Case: Molded plastic, SMA, SMB, DO-41
- Terminals: Solder plated, solderable per MIL-STD-750, Method 2026
- Polarity: Color Band denotes cathode end
- SMA Approx. Weight: 0.0239 ounces, 0.068 grams
- SMB Approx. Weight: 0.0032 ounces, 0.092 grams
- DO-41 Approx. Weight: 0.012 ounces, 0.034 grams
- Marking: Part number

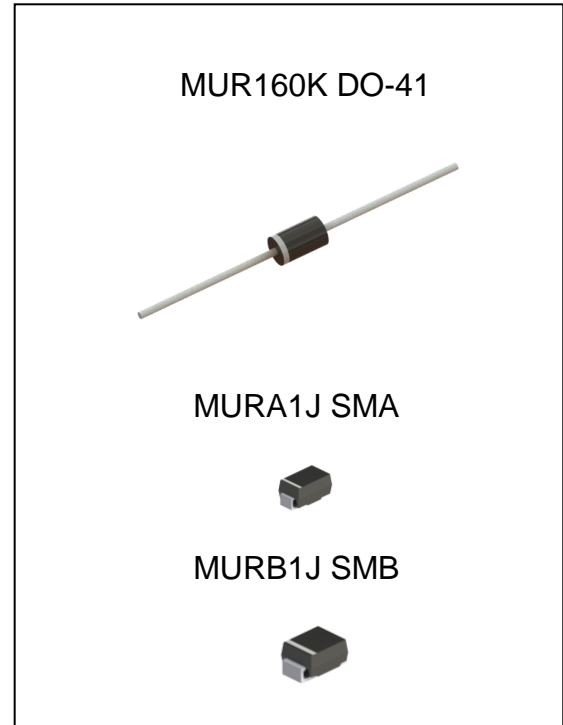
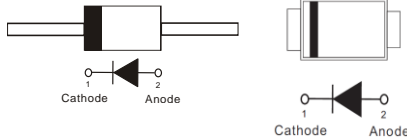

### Maximum Ratings ( $T_A=25^{\circ}\text{C}$ unless otherwise noted)

PARAMETER	SYMBOL	LIMIT	UNIT
Maximum repetitive peak reverse voltage	$V_{RRM}$	600	V
Maximum rms voltage	$V_{RMS}$	420	V
Maximum dc blocking voltage	$V_R$	600	V
Maximum average forward current	$I_{F(AV)}$	1	A
Peak forward surge current : 8.3ms single half sine-wave superimposed on rated load	$I_{FSM}$	30	A
Maximum forward voltage at 1A	$V_F$	1.25	V
Maximum dc reverse current at rated dc blocking voltage	$I_R$	5	$\mu\text{A}$
Operating and storage temperature range	$T_J, T_{STG}$	-55 to +175	$^{\circ}\text{C}$



# MURA1J / MURB1J / MUR160K

Maximum Ratings ( $T_A=25^{\circ}\text{C}$  unless otherwise noted)

PARAMETER		SYMBOL	LIMIT	UNIT
Maximum reverse recovery time	(Note 4)	$T_{RR}$	50	ns
Typical thermal resistance	SMA(Note 3)	$R_{\theta JA}$	150	$^{\circ}\text{C/W}$
	SMB(Note 3)	$R_{\theta JA}$	135	
	SMA(Note 1)	$R_{\theta JC}$	25	
	SMB(Note 1)	$R_{\theta JC}$	20	
	DO-41(Note 2)	$R_{\theta JL}$	55	

Note : 1. Mounted on a FR4 PCB, single-sided copper, with  $100\text{cm}^2$  copper pad area

2. The testing condition of the thermal resistance (junction to lead) is based on 10 mm lead length between two 10cm x 10cm FR4 PCB single-sided copper pad

3. Mounted on a FR4 PCB, single-sided copper, mini pad

4. Reverse Recovery Test Conditions :  $I_F=0.5\text{A}$ ,  $I_R=1\text{A}$ , Recover to 0.25A

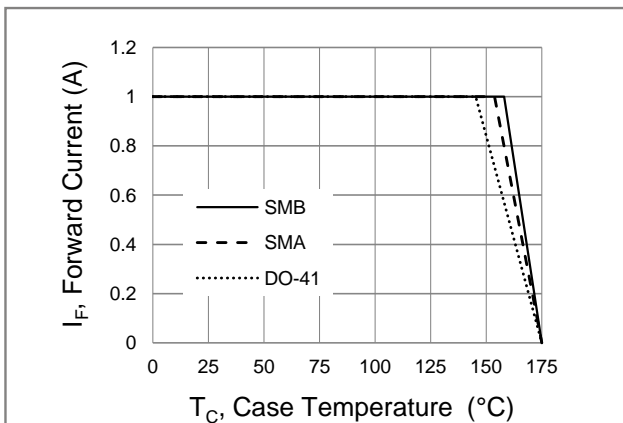

**Fig.1 Forward Current Derating Curve**

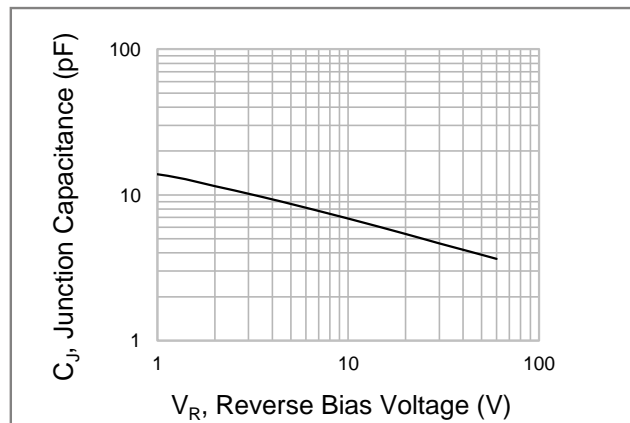

**Fig.2 Typical Junction Capacitance**

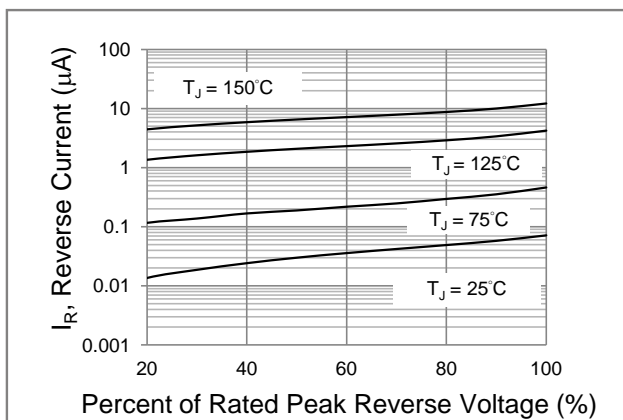

**Fig.3 Typical Reverse Characteristics**

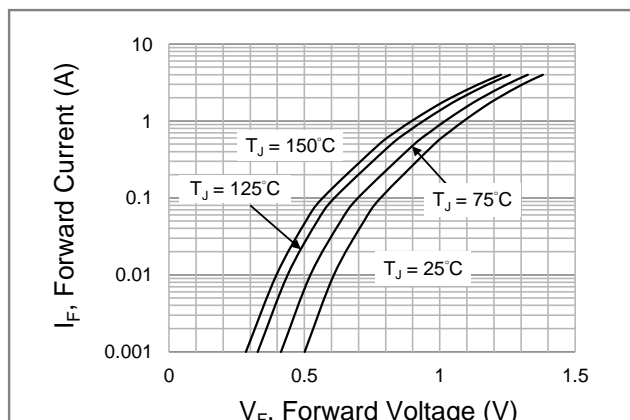

**Fig.4 Typical Forward Characteristics**



# MURA1J / MURB1J / MUR160K

## PART NO PACKING CODE VERSION

Part No Packing Code	Package Type	Packing type	Marking	Version
MUR160K_AY_00001	DO-41	5K pcs/ TB 52mm	MUR160K	Halogen free
MUR160K_AY_10001	DO-41	5K pcs/ TB 52mm	MUR160K	RoHS
MURA1J_R1_00001	SMA	1.8K pcs / 7" reel	MURA1J	Halogen free
MURB1J_R1_00001	SMB	0.8K pcs / 7" reel	MURB1J	Halogen free

## MOUNTING PAD LAYOUT

**SMA / DO-214AC**

Unit : inch(mm)

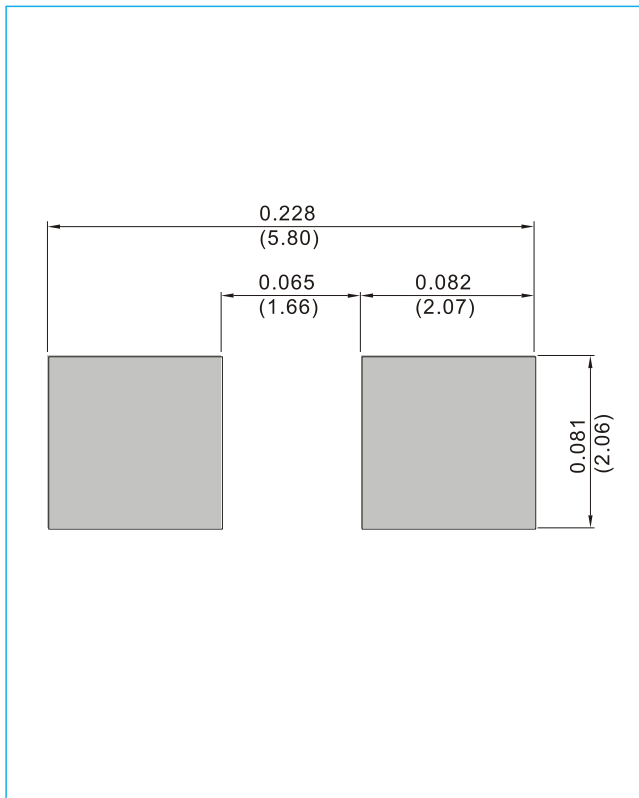

**SMB / DO-214AA**

Unit : inch(mm)

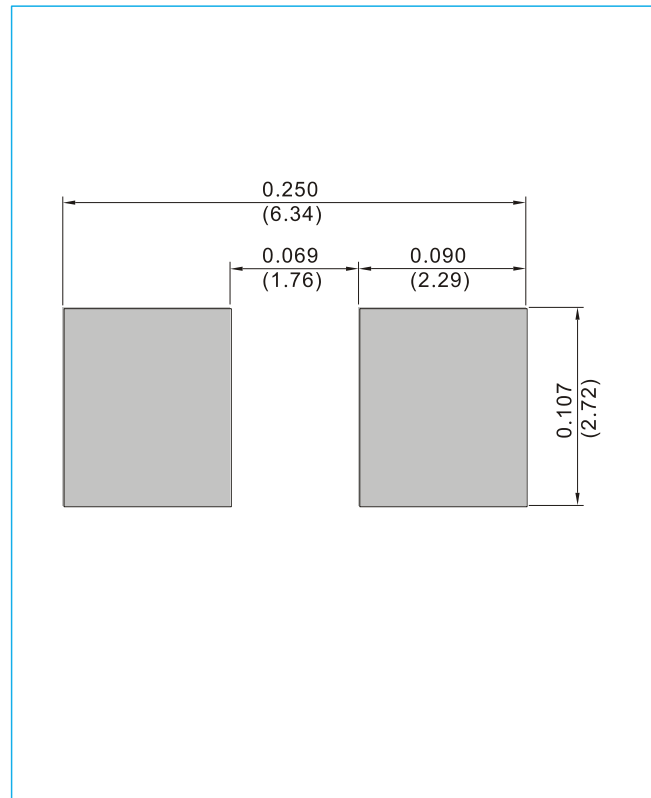



# MURA1J / MURB1J / MUR160K

## SMA / DO-214AC

Unit : inch(mm)

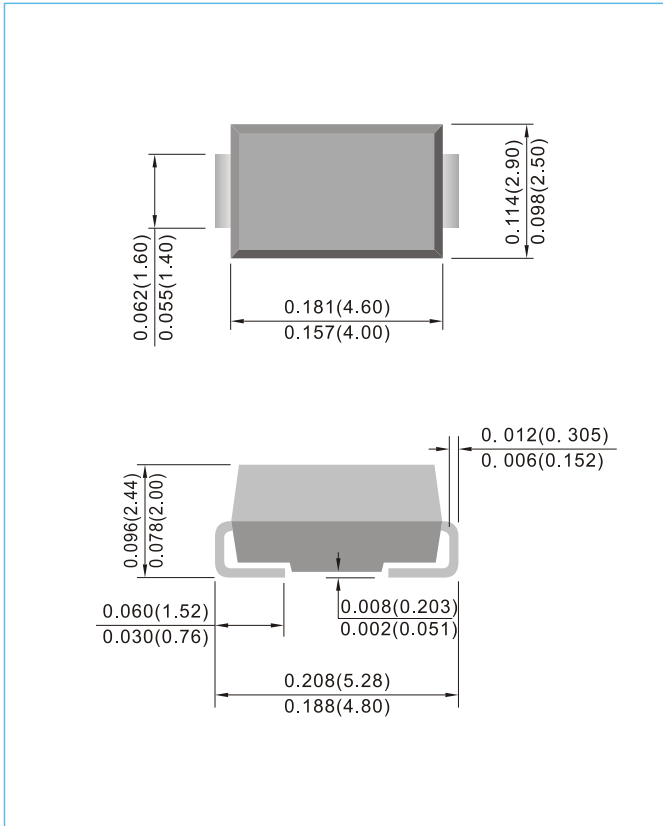

## SMB / DO-214AA

Unit : inch(mm)

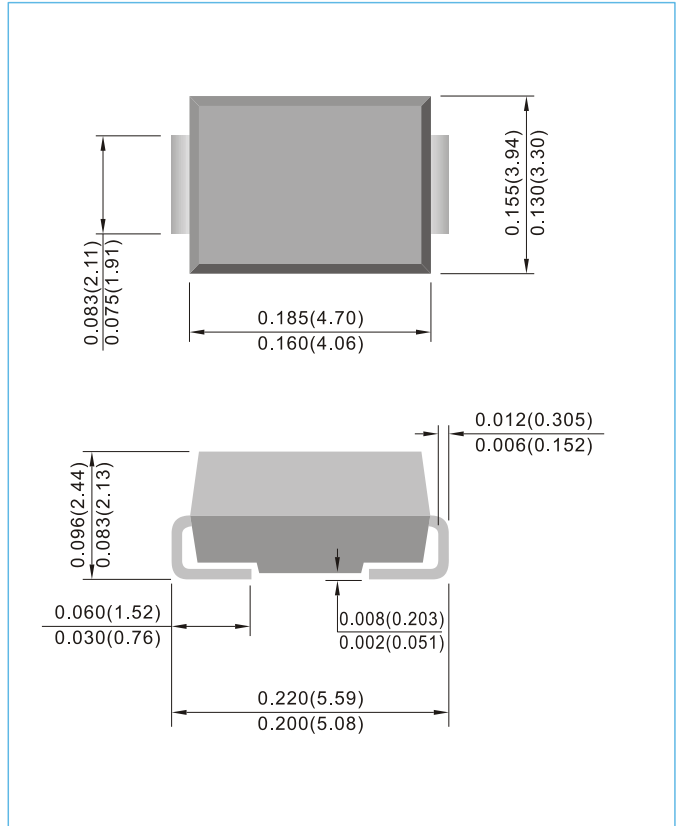

## DO-41

Unit : inch(mm)

