

RF Power Field Effect Transistors

N-Channel Enhancement-Mode Lateral MOSFETs

Designed for Class A or Class AB base station applications with frequencies up to 1500 MHz. Suitable for analog and digital modulation and multicarrier amplifier applications.

- Typical Two-Tone Performance at 960 MHz: $V_{DD} = 28$ Volts, $I_{DQ} = 125$ mA, $P_{out} = 10$ Watts PEP
Power Gain — 18 dB
Drain Efficiency — 32%
IMD — -37 dBc
- Capable of Handling 10:1 VSWR, @ 28 Vdc, 960 MHz, 10 Watts CW Output Power

Features

- Characterized with Series Equivalent Large-Signal Impedance Parameters
- On-Chip RF Feedback for Broadband Stability
- Qualified Up to a Maximum of 32 V_{DD} Operation
- Integrated ESD Protection
- 225°C Capable Plastic Package
- RoHS Compliant
- In Tape and Reel. R1 Suffix = 500 Units per 24 mm, 13 inch Reel.

MW6S010NR1
MW6S010GNR1

450 - 1500 MHz, 10 W, 28 V
LATERAL N-CHANNEL
BROADBAND RF POWER MOSFETs

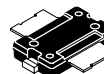

CASE 1265-09, STYLE 1
TO-270-2
PLASTIC
MW6S010NR1

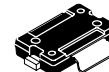

CASE 1265A-03, STYLE 1
TO-270-2 GULL
PLASTIC
MW6S010GNR1

Table 1. Maximum Ratings

Rating	Symbol	Value	Unit
Drain-Source Voltage	V_{DSS}	-0.5, +68	Vdc
Gate-Source Voltage	V_{GS}	-0.5, +12	Vdc
Storage Temperature Range	T_{stg}	-65 to +150	°C
Case Operating Temperature	T_C	150	°C
Operating Junction Temperature (1,2)	T_J	225	°C

Table 2. Thermal Characteristics

Characteristic	Symbol	Value (2,3)	Unit
Thermal Resistance, Junction to Case Case Temperature 80°C, 10 W PEP	$R_{\theta JC}$	2.85	°C/W

1. Continuous use at maximum temperature will affect MTTF.
2. MTTF calculator available at <http://www.freescale.com/rf>. Select Software & Tools/Development Tools/Calculators to access MTTF calculators by product.
3. Refer to AN1955, *Thermal Measurement Methodology of RF Power Amplifiers*. Go to <http://www.freescale.com/rf>. Select Documentation/Application Notes - AN1955.

Table 3. ESD Protection Characteristics

Test Methodology	Class
Human Body Model (per JESD22-A114)	1A
Machine Model (per EIA/JESD22-A115)	A
Charge Device Model (per JESD22-C101)	III

Table 4. Moisture Sensitivity Level

Test Methodology	Rating	Package Peak Temperature	Unit
Per JESD22-A113, IPC/JEDEC J-STD-020	3	260	°C

Table 5. Electrical Characteristics ($T_A = 25^\circ\text{C}$ unless otherwise noted)

Characteristic	Symbol	Min	Typ	Max	Unit
----------------	--------	-----	-----	-----	------

Off Characteristics

Zero Gate Voltage Drain Leakage Current ($V_{DS} = 68\text{ Vdc}$, $V_{GS} = 0\text{ Vdc}$)	I_{DSS}	—	—	10	μAdc
Zero Gate Voltage Drain Leakage Current ($V_{DS} = 28\text{ Vdc}$, $V_{GS} = 0\text{ Vdc}$)	I_{DSS}	—	—	1	μAdc
Gate-Source Leakage Current ($V_{GS} = 5\text{ Vdc}$, $V_{DS} = 0\text{ Vdc}$)	I_{GSS}	—	—	1	μAdc

On Characteristics

Gate Threshold Voltage ($V_{DS} = 10\text{ Vdc}$, $I_D = 100\ \mu\text{Adc}$)	$V_{GS(th)}$	1.5	2.3	3	Vdc
Gate Quiescent Voltage ($V_{DD} = 28\text{ Vdc}$, $I_D = 125\text{ mAdc}$, Measured in Functional Test)	$V_{GS(Q)}$	2	3.1	4	Vdc
Drain-Source On-Voltage ($V_{GS} = 10\text{ Vdc}$, $I_D = 0.3\text{ Adc}$)	$V_{DS(on)}$	—	0.27	0.35	Vdc

Dynamic Characteristics

Reverse Transfer Capacitance ($V_{DS} = 28\text{ Vdc} \pm 30\text{ mV(rms)ac}$ @ 1 MHz, $V_{GS} = 0\text{ Vdc}$)	C_{rss}	—	0.32	—	pF
Output Capacitance ($V_{DS} = 28\text{ Vdc} \pm 30\text{ mV(rms)ac}$ @ 1 MHz, $V_{GS} = 0\text{ Vdc}$)	C_{oss}	—	10	—	pF
Input Capacitance ($V_{DS} = 28\text{ Vdc}$, $V_{GS} = 0\text{ Vdc} \pm 30\text{ mV(rms)ac}$ @ 1 MHz)	C_{iss}	—	23	—	pF

Functional Tests (In Freescale Test Fixture, 50 ohm system) $V_{DD} = 28\text{ Vdc}$, $I_{DQ} = 125\text{ mA}$, $P_{out} = 10\text{ W PEP}$, $f = 960\text{ MHz}$, Two-Tone Test, 100 kHz Tone Spacing

Power Gain	G_{ps}	17.5	18	20.5	dB
Drain Efficiency	η_D	31	32	—	%
Intermodulation Distortion	IMD	—	-37	-33	dBc
Input Return Loss	IRL	—	-18	-10	dB

Typical Performances (In Freescale 450 MHz Demo Board, 50 ohm system) $V_{DD} = 28\text{ Vdc}$, $I_{DQ} = 150\text{ mA}$, $P_{out} = 10\text{ W PEP}$, 420-470 MHz, Two-Tone Test, 100 kHz Tone Spacing

Power Gain	G_{ps}	—	20	—	dB
Drain Efficiency	η_D	—	33	—	%
Intermodulation Distortion	IMD	—	-40	—	dBc
Input Return Loss	IRL	—	-10	—	dB

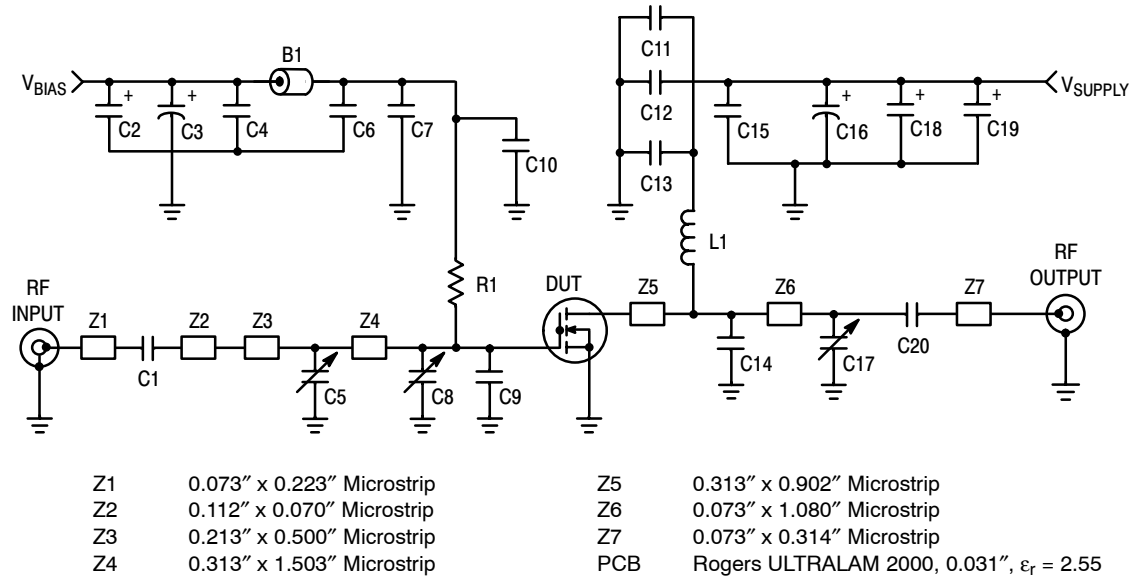

Figure 1. MW6S010NR1(GNR1) Test Circuit Schematic — 900 MHz

Table 6. MW6S010NR1(GNR1) Test Circuit Component Designations and Values — 900 MHz

Part	Description	Part Number	Manufacturer
B1	Ferrite Bead	2743019447	Fair-Rite
C1, C6, C11, C20	47 pF Chip Capacitors	ATC100B470JT500XT	ATC
C2, C18, C19	22 μ F, 35 V Tantalum Capacitors	T491D226K035AT	Kemet
C3, C16	220 μ F, 63 V Electrolytic Capacitors, Radial	2222-136-68221	Vishay
C4, C15	0.1 μ F Chip Capacitors	CDR33BX104AKWS	Kemet
C5, C8, C17	0.8-8.0 pF Variable Capacitors, Gigatrim	272915L	Johanson
C7, C12	24 pF Chip Capacitors	ATC100B240JT500XT	ATC
C9, C10, C13	6.8 pF Chip Capacitors	ATC100B6R8JT500XT	ATC
C14	7.5 pF Chip Capacitor	ATC100B7R5JT500XT	ATC
L1	12.5 nH Inductor	A04T-5	Coilcraft
R1	1 k Ω , 1/4 W Chip Resistor	CRCW12061001FKEA	Vishay

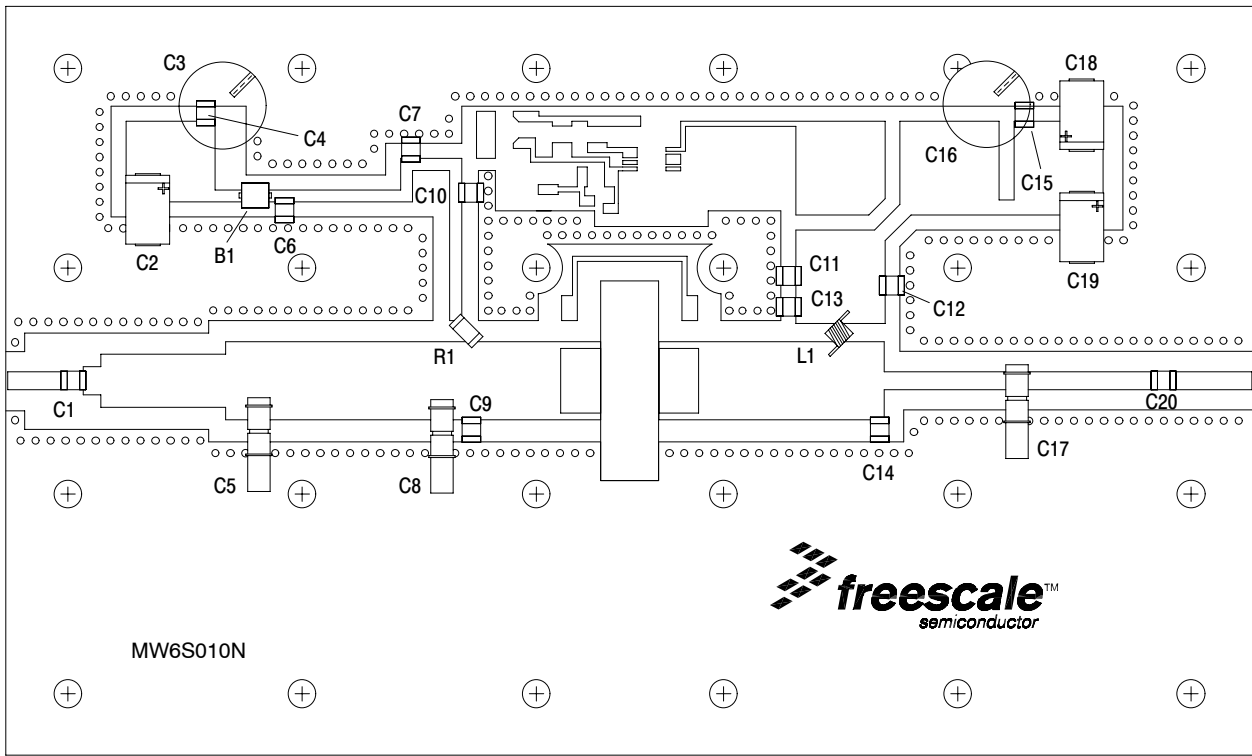

Figure 2. MW6S010NR1(GNR1) Test Circuit Component Layout — 900 MHz

TYPICAL CHARACTERISTICS — 900 MHz

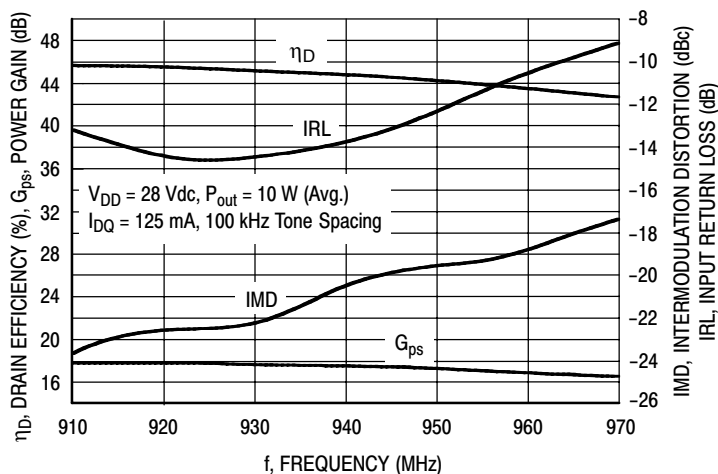

Figure 3. Two-Tone Wideband Performance @ P_{out} = 10 Watts

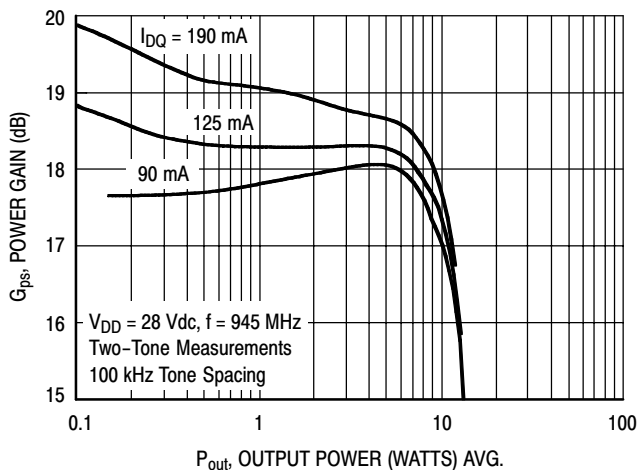

Figure 4. Two-Tone Power Gain versus Output Power

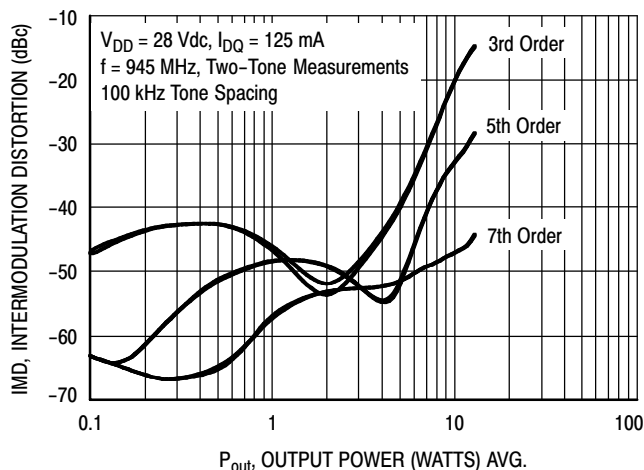

Figure 5. Intermodulation Distortion Products versus Output Power

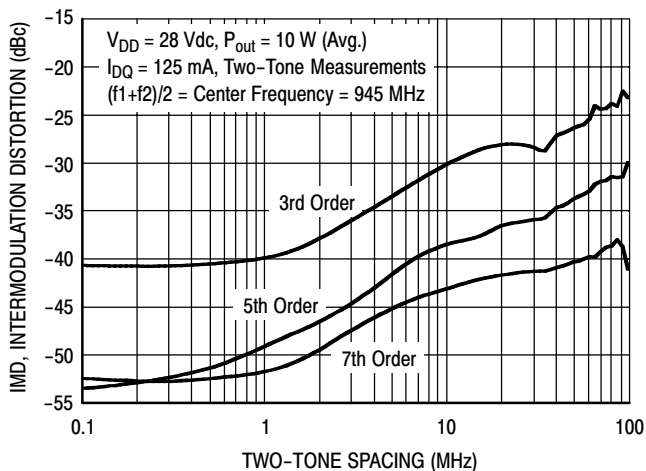

Figure 6. Intermodulation Distortion Products versus Tone Spacing

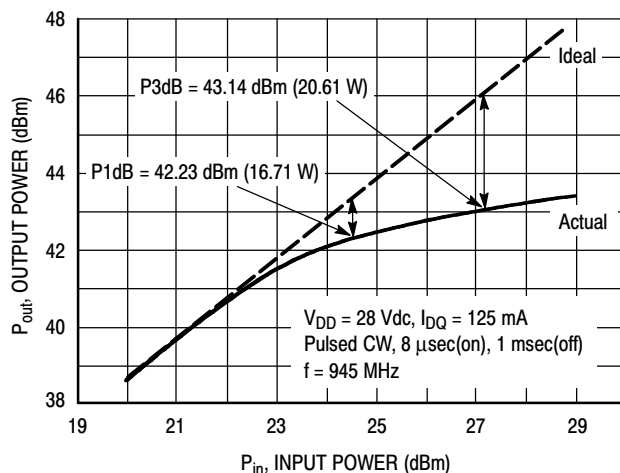

Figure 7. Pulse CW Output Power versus Input Power

TYPICAL CHARACTERISTICS — 900 MHz

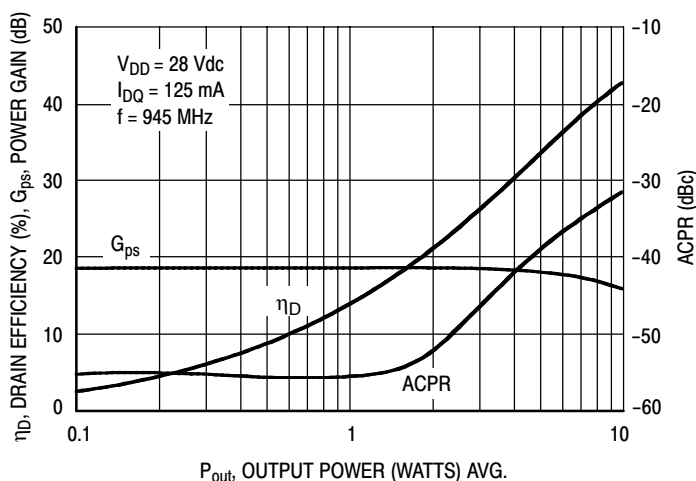

Figure 8. Single-Carrier CDMA ACPR, Power Gain and Power Added Efficiency versus Output Power

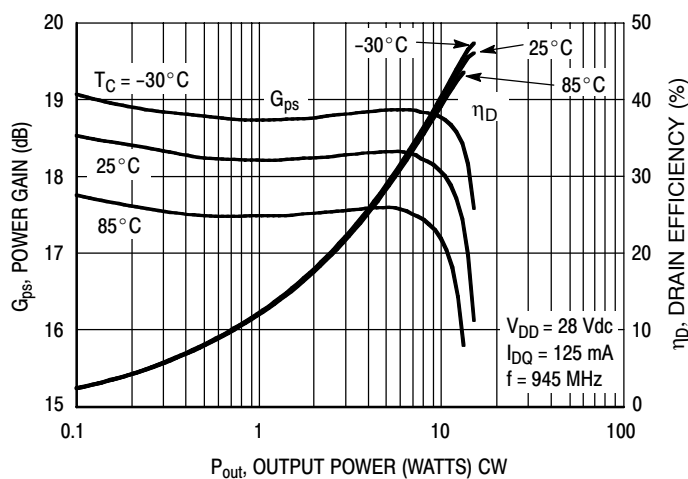

Figure 9. Power Gain and Power Added Efficiency versus Output Power

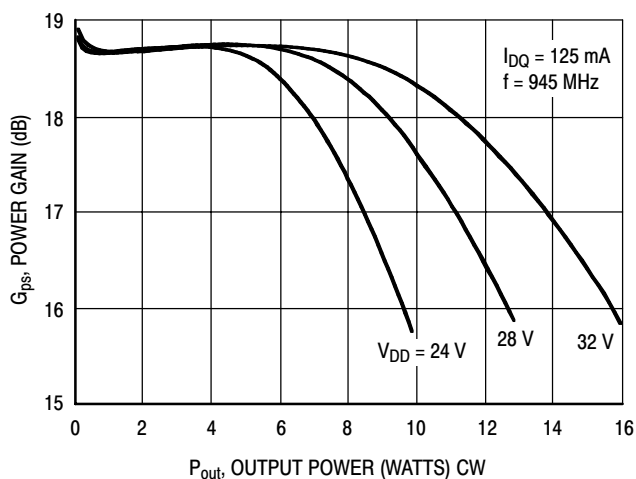

Figure 10. Power Gain versus Output Power

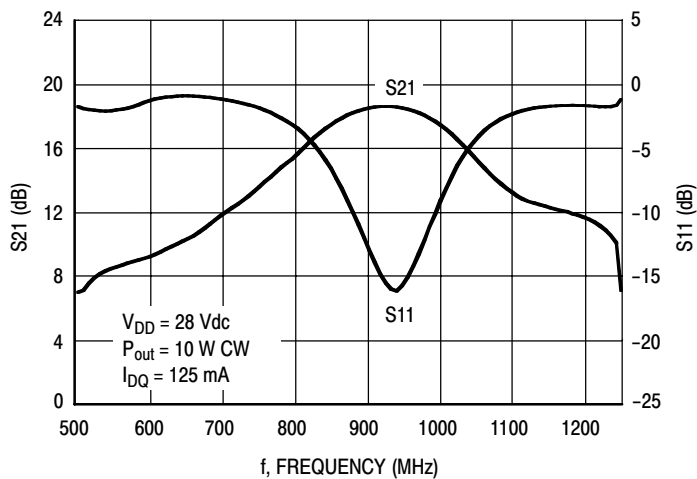
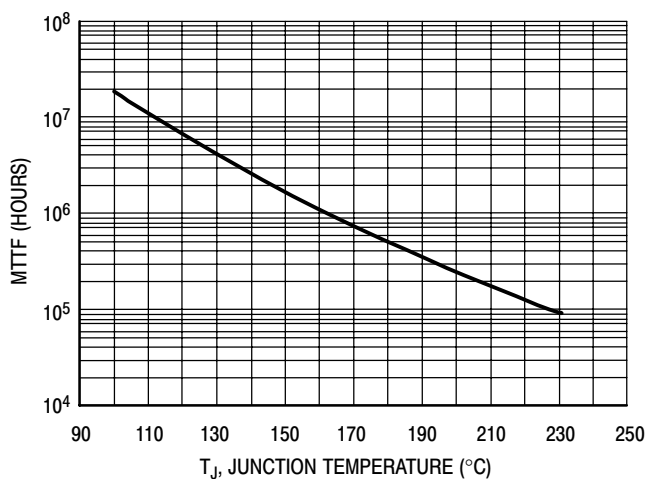

Figure 11. Broadband Frequency Response

TYPICAL CHARACTERISTICS



This above graph displays calculated MTTF in hours when the device is operated at $V_{DD} = 28$ Vdc, $P_{out} = 10$ W PEP, and $\eta_D = 32\%$.

MTTF calculator available at <http://www.freescale.com/rf>. Select Software & Tools/Development Tools/Calculators to access MTTF calculators by product.

Figure 12. MTTF Factor versus Junction Temperature

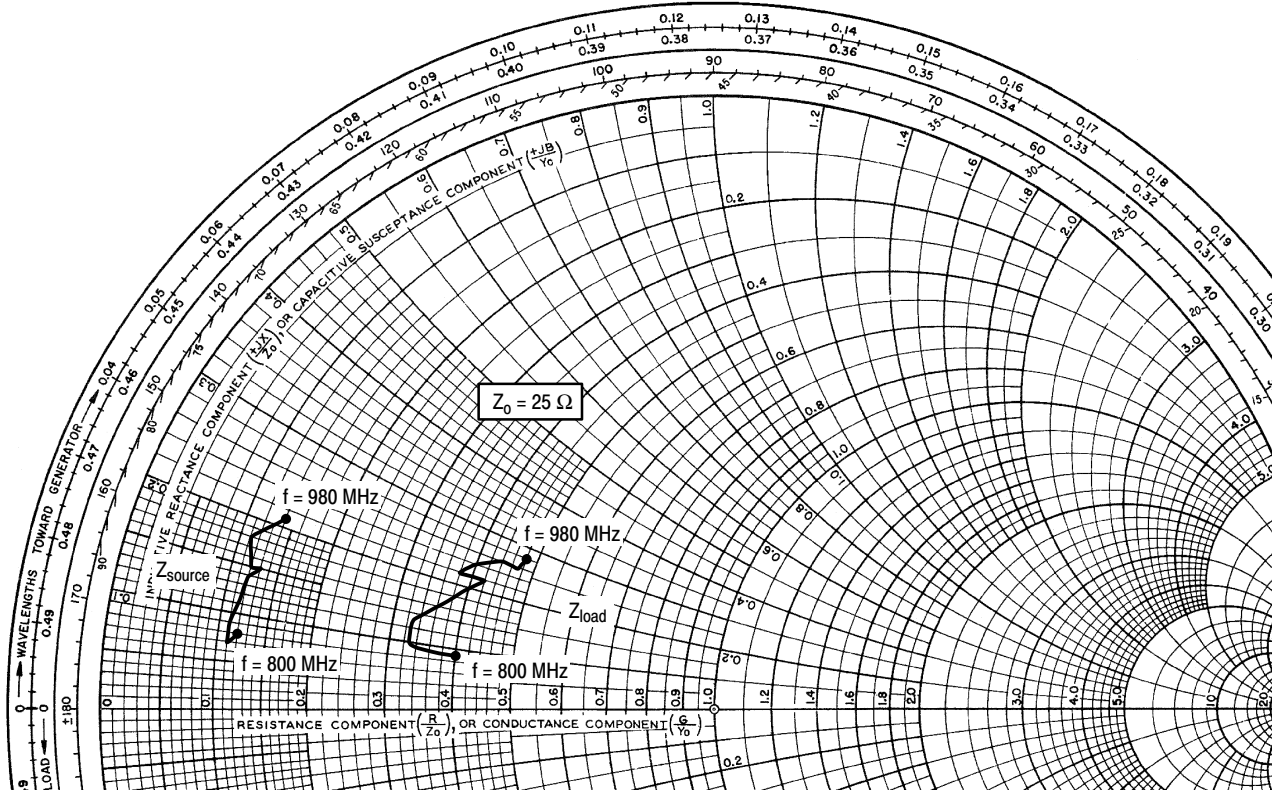

$V_{DD} = 28 \text{ Vdc}$, $I_{DQ} = 125 \text{ mA}$, $P_{out} = 10 \text{ W PEP}$

f MHz	Z_{source} Ω	Z_{load} Ω
800	$3.1 + j1.9$	$10.1 + j2.3$
820	$2.8 + j1.7$	$8.3 + j2.5$
840	$2.7 + j2.2$	$8.2 + j3.3$
860	$3.1 + j3.4$	$9.8 + j4.8$
880	$3.3 + j3.8$	$10.6 + j5.6$
900	$2.9 + j3.7$	$9.5 + j5.5$
920	$2.8 + j4.4$	$10.1 + j5.9$
940	$3.0 + j4.7$	$11.0 + j6.4$
960	$3.2 + j4.9$	$11.8 + j6.6$
980	$3.6 + j5.2$	$12.1 + j7.1$

Z_{source} = Test circuit impedance as measured from gate to ground.

Z_{load} = Test circuit impedance as measured from drain to ground.

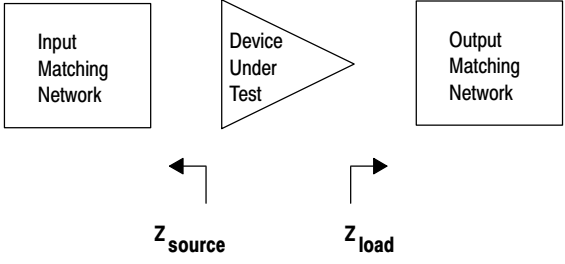
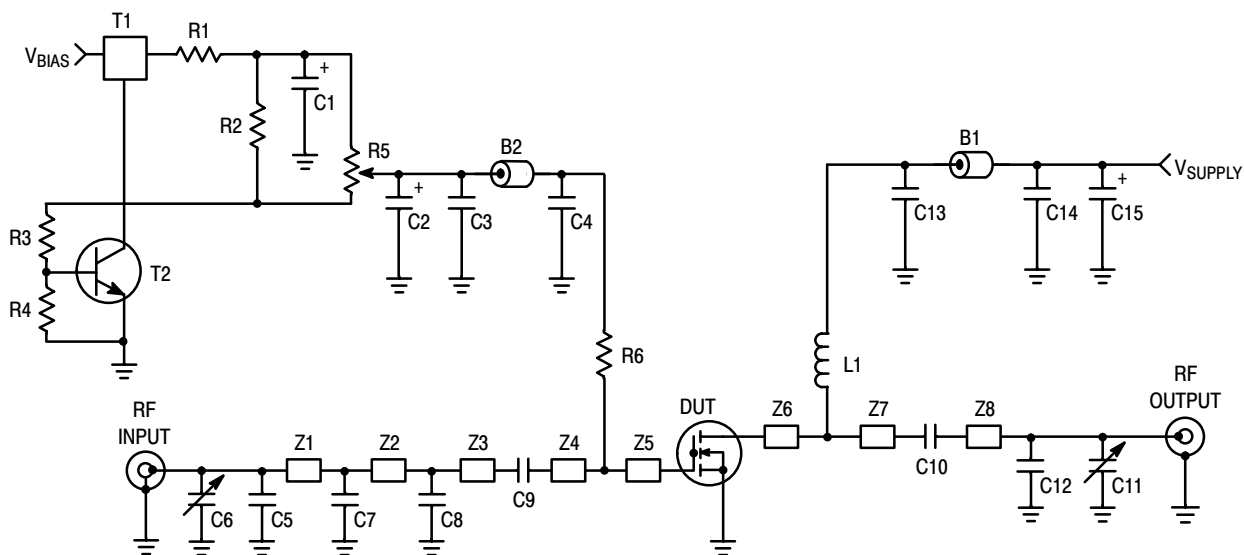

Figure 13. Series Equivalent Source and Load Impedance — 900 MHz



Z1	0.540" x 0.080" Microstrip	Z5	0.475" x 0.330" Microstrip
Z2	0.365" x 0.080" Microstrip	Z6	0.475" x 0.325" Microstrip
Z3	0.225" x 0.080" Microstrip	Z8	1.250" x 0.080" Microstrip
Z4, Z7	0.440" x 0.080" Microstrip	PCB	Rogers ULTRALAM 2000, 0.030", $\epsilon_r = 2.55$

Figure 14. MW6S010NR1(GNR1) Test Circuit Schematic — 450 MHz

Table 7. MW6S010NR1(GNR1) Test Circuit Component Designations and Values — 450 MHz

Part	Description	Part Number	Manufacturer
B1, B2	Ferrite Bead	2743019447	Fair-Rite
C1	1 μ F, 35 V Tantalum Capacitor	T491C105K050AT	Kemet
C2, C15	22 μ F, 35 V Tantalum Capacitors	T491X226K035AT	Kemet
C3, C14	0.1 μ F Chip Capacitors	C1210C104K5RAC	Kemet
C4, C9, C10, C13	330 pF Chip Capacitors	ATC700A331JT150XT	ATC
C5	4.3 pF Chip Capacitor	ATC100B4R3JT500XT	ATC
C6, C11	0.6-8.0 pF Variable Capacitors	27291SL	Johanson
C7, C8, C12	4.7 pF Chip Capacitors	ATC100B4R7JT500XT	ATC
L1	39 μ H Chip Inductor	ISC-1210	Vishay
R1	10 Ω Chip Resistor	CRCW080510R0FKEA	Vishay
R2	1 k Ω Chip Resistor	CRCW08051001FKEA	Vishay
R3	1.2 k Ω Chip Resistor	CRCW08051201FKEA	Vishay
R4	2.2 k Ω Chip Resistor	CRCW08052201FKEA	Vishay
R5	5 k Ω Potentiometer	1224W	Bourns
R6	1 k Ω Chip Resistor	CRCW12061001FKEA	Vishay
T1	5 Volt Regulator, Micro 8	LP2951CDMR2G	On Semiconductor
T2	NPN Transistor, SOT-23	BC847ALT1G	On Semiconductor

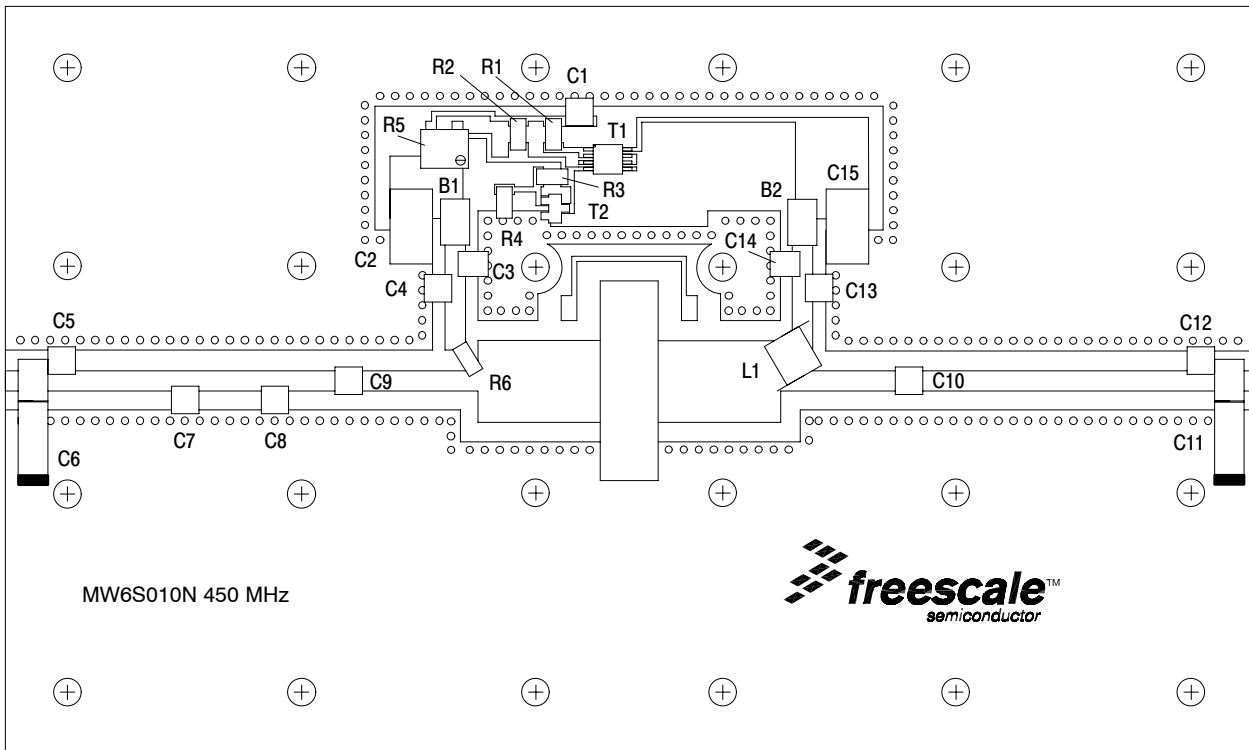

Figure 15. MW6S010NR1(GNR1) Test Circuit Component Layout — 450 MHz

TYPICAL CHARACTERISTICS — 450 MHz

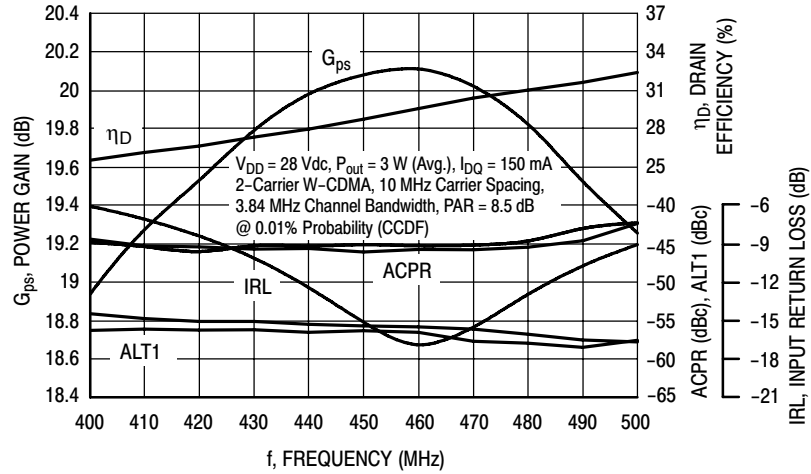

Figure 16. 2-Carrier W-CDMA Broadband Performance @ $P_{out} = 3$ Watts Avg.

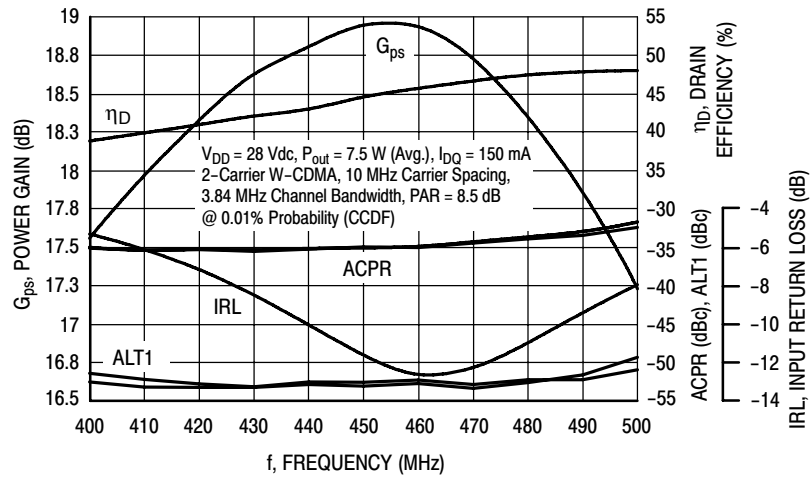

Figure 17. 2-Carrier W-CDMA Broadband Performance @ $P_{out} = 7.5$ Watts Avg.

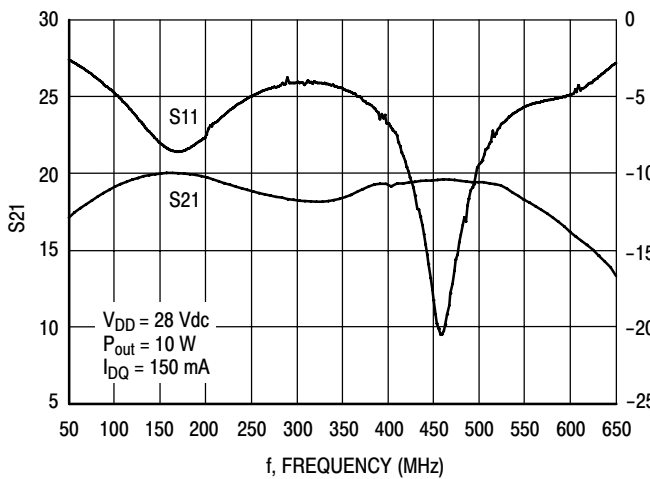

Figure 18. Broadband Frequency Response

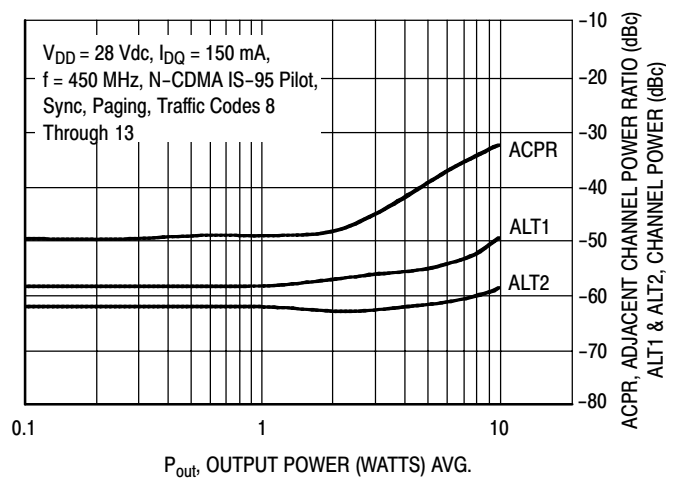
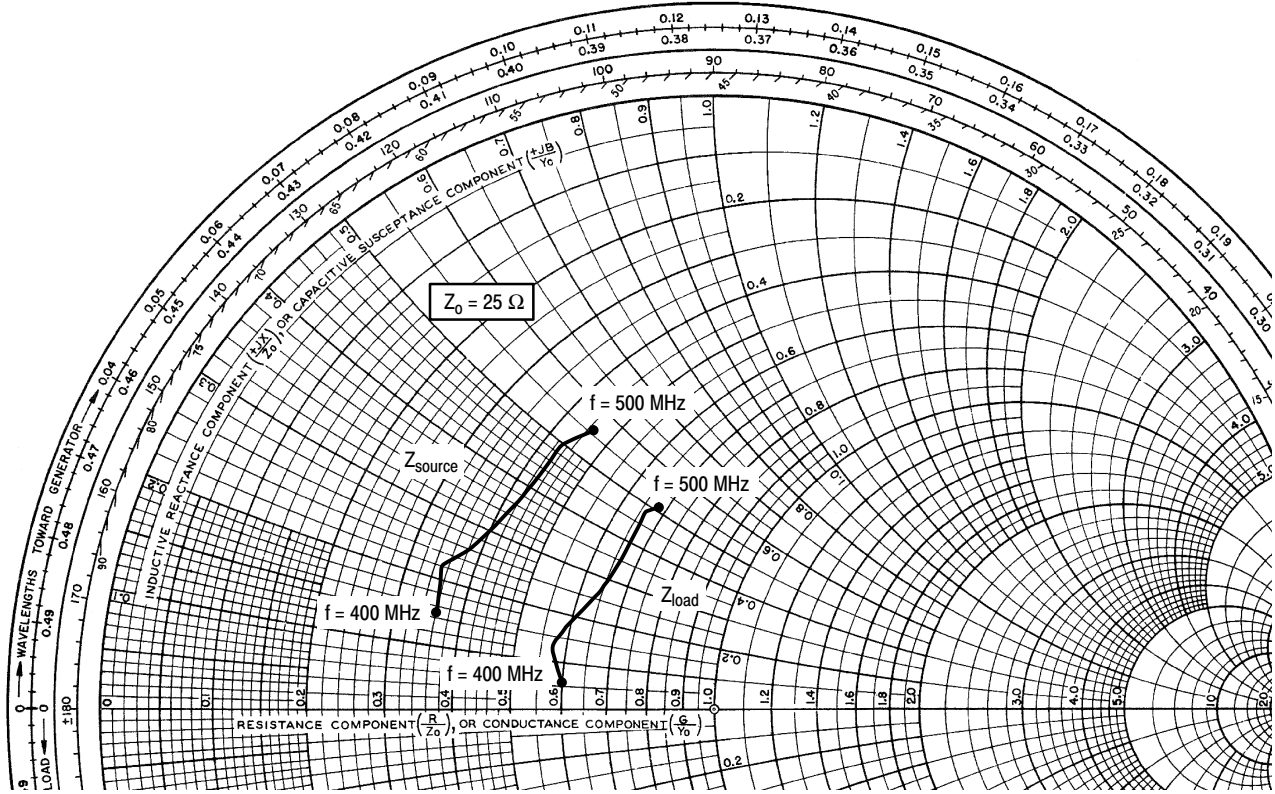

Figure 19. Single-Carrier N-CDMA ACPR, ALT1 and ALT2 versus Output Power



$V_{DD} = 28 \text{ Vdc}$, $I_{DQ} = 150 \text{ mA}$, $P_{out} = 10 \text{ W PEP}$

f MHz	Z_{source} Ω	Z_{load} Ω
400	$9.0 + j3.8$	$15.0 + j1.4$
420	$8.8 + j5.4$	$14.3 + j3.3$
440	$9.6 + j6.6$	$15.0 + j4.7$
460	$10.6 + j9.5$	$16.3 + j7.3$
480	$10.7 + j12.6$	$16.4 + j11.1$
500	$11.5 + j13.9$	$16.9 + j12.7$

Z_{source} = Test circuit impedance as measured from gate to ground.

Z_{load} = Test circuit impedance as measured from drain to ground.

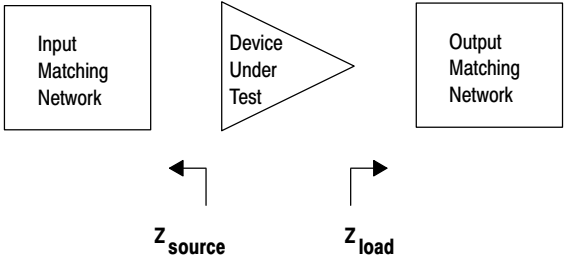
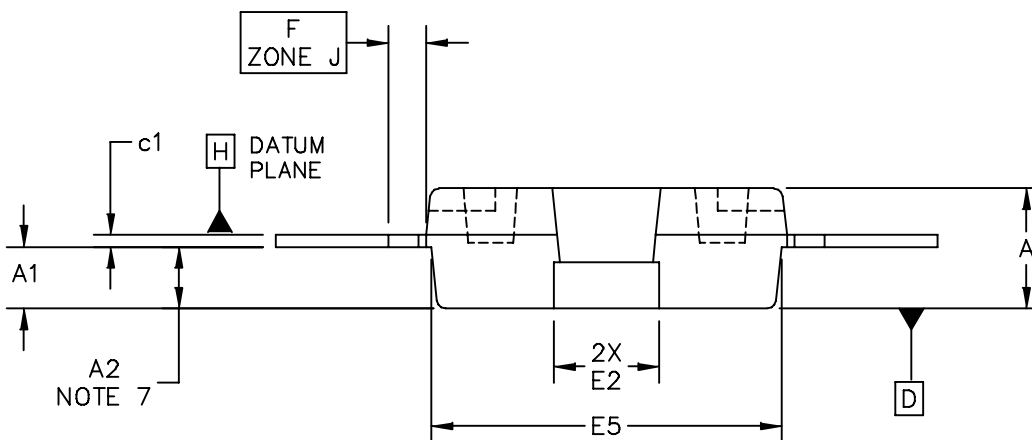
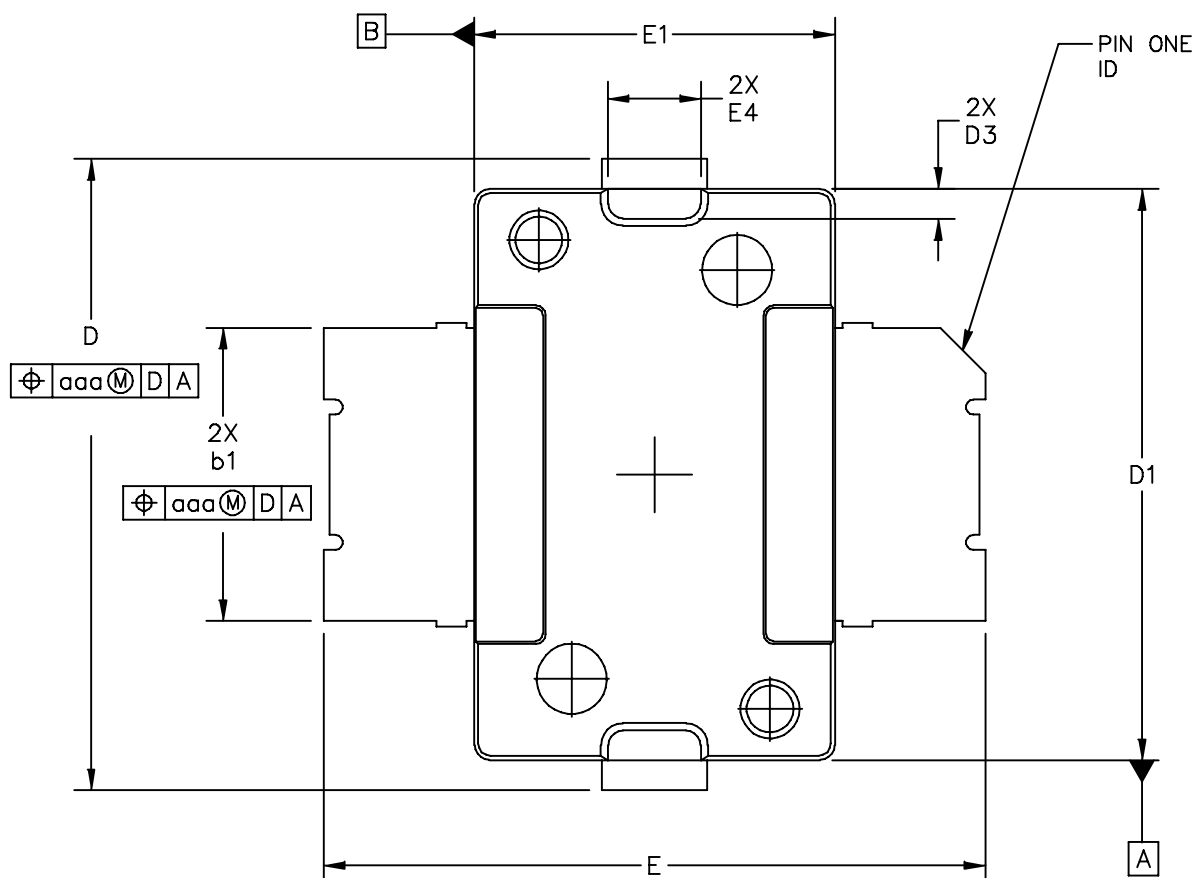
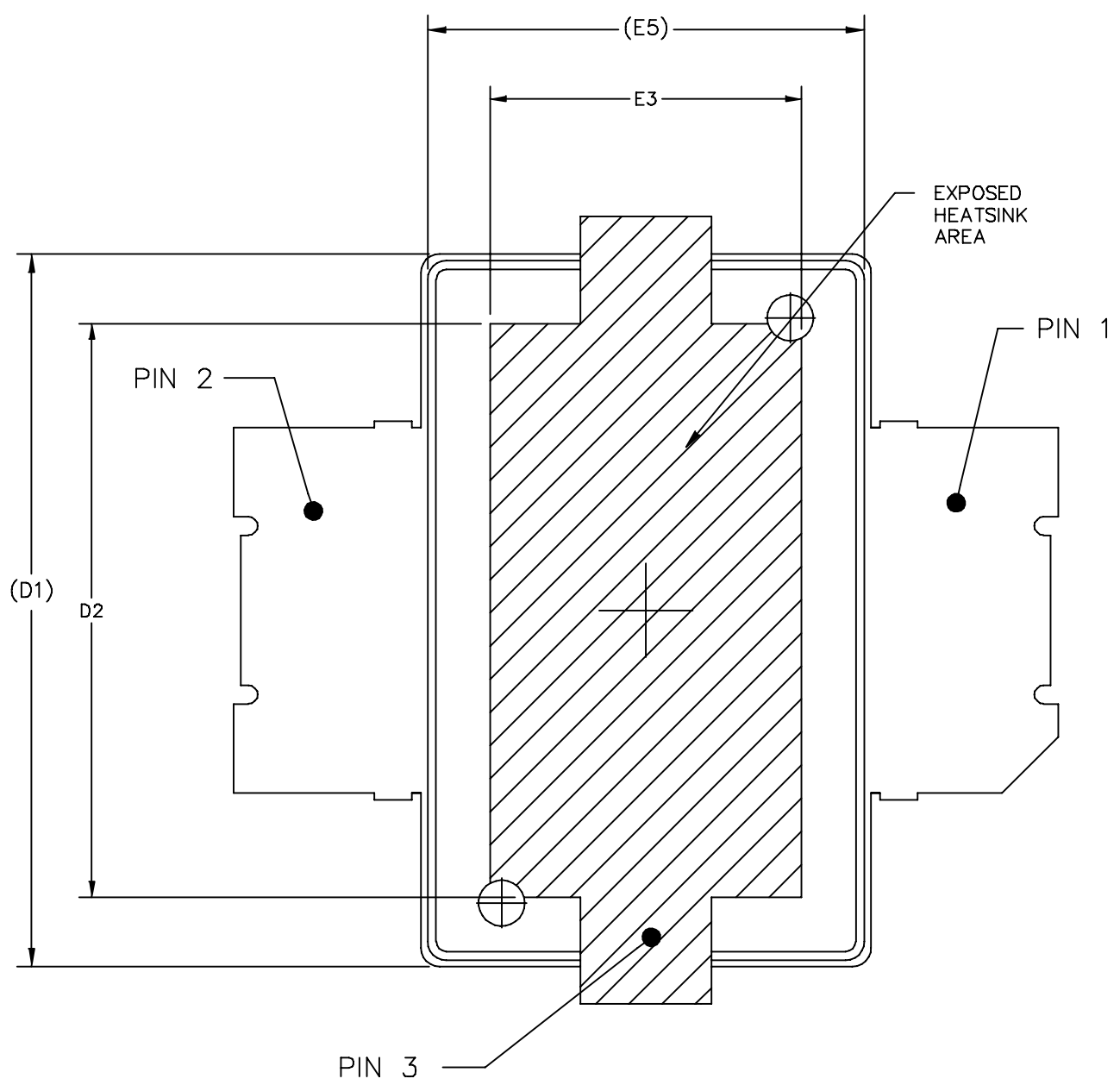

Figure 20. Series Equivalent Source and Load Impedance — 450 MHz

PACKAGE DIMENSIONS



© FREESCALE SEMICONDUCTOR, INC. ALL RIGHTS RESERVED.		MECHANICAL OUTLINE		PRINT VERSION NOT TO SCALE	
TITLE: TO-270 SURFACE MOUNT		DOCUMENT NO: 98ASH98117A		REV: K	
		CASE NUMBER: 1265-09		29 JUN 2007	
		STANDARD: JEDEC TO-270 AA			



BOTTOM VIEW

© FREESCALE SEMICONDUCTOR, INC. ALL RIGHTS RESERVED.	MECHANICAL OUTLINE	PRINT VERSION NOT TO SCALE	
TITLE: TO-270 SURFACE MOUNT	DOCUMENT NO: 98ASH98117A	REV: K	
	CASE NUMBER: 1265-09	29 JUN 2007	
	STANDARD: JEDEC TO-270 AA		

NOTES:

1. CONTROLLING DIMENSION: INCH
2. INTERPRET DIMENSIONS AND TOLERANCES PER ASME Y14.5M-1994.
3. DATUM PLANE -H- IS LOCATED AT TOP OF LEAD AND IS COINCIDENT WITH THE LEAD WHERE THE LEAD EXITS THE PLASTIC BODY AT THE TOP OF THE PARTING LINE.
4. DIMENSIONS "D1" AND "E1" DO NOT INCLUDE MOLD PROTRUSION. ALLOWABLE PROTRUSION IS .006 PER SIDE. DIMENSIONS "D1 AND "E1" DO INCLUDE MOLD MISMATCH AND ARE DETERMINED AT DATUM PLANE -H-.
5. DIMENSION "b1" DOES NOT INCLUDE DAMBAR PROTRUSION. ALLOWABLE DAMBAR PROTRUSION SHALL BE .005 TOTAL IN EXCESS OF THE "b1" DIMENSION AT MAXIMUM MATERIAL CONDITION.
6. DATUMS -A- AND -B- TO BE DETERMINED AT DATUM PLANE -H-.
7. DIMENSION "A2" APPLIES WITHIN ZONE "J" ONLY.
8. DIMENSIONS "D" AND "E2" DO NOT INCLUDE MOLD PROTRUSION. OVERALL LENGTH INCLUDING MOLD PROTRUSION SHOULD NOT EXCEED 0.430 INCH FOR DIMENSION "D" AND 0.080 INCH FOR DIMENSION "E2". DIMENSIONS "D" AND "E2" DO INCLUDE MOLD MISMATCH AND ARE DETERMINED AT DATUM PLANE -D-.

STYLE 1:

- PIN 1 - DRAIN
- PIN 2 - GATE
- PIN 3 - SOURCE

DIM	INCH		MILLIMETER		DIM	INCH		MILLIMETER	
	MIN	MAX	MIN	MAX		MIN	MAX	MIN	MAX
A	.078	.082	1.98	2.08	F	.025 BSC		0.64 BSC	
A1	.039	.043	0.99	1.09	b1	.193	.199	4.90	5.06
A2	.040	.042	1.02	1.07	c1	.007	.011	0.18	0.28
D	.416	.424	10.57	10.77	aaa	.004		0.10	
D1	.378	.382	9.60	9.70					
D2	.290	----	7.37	----					
D3	.016	.024	0.41	0.61					
E	.436	.444	11.07	11.28					
E1	.238	.242	6.04	6.15					
E2	.066	.074	1.68	1.88					
E3	.150	----	3.81	----					
E4	.058	.066	1.47	1.68					
E5	.231	.235	5.87	5.97					

© FREESCALE SEMICONDUCTOR, INC. ALL RIGHTS RESERVED.		MECHANICAL OUTLINE		PRINT VERSION NOT TO SCALE	
TITLE: TO-270 SURFACE MOUNT		DOCUMENT NO: 98ASH98117A		REV: K	
		CASE NUMBER: 1265-09		29 JUN 2007	
		STANDARD: JEDEC TO-270 AA			

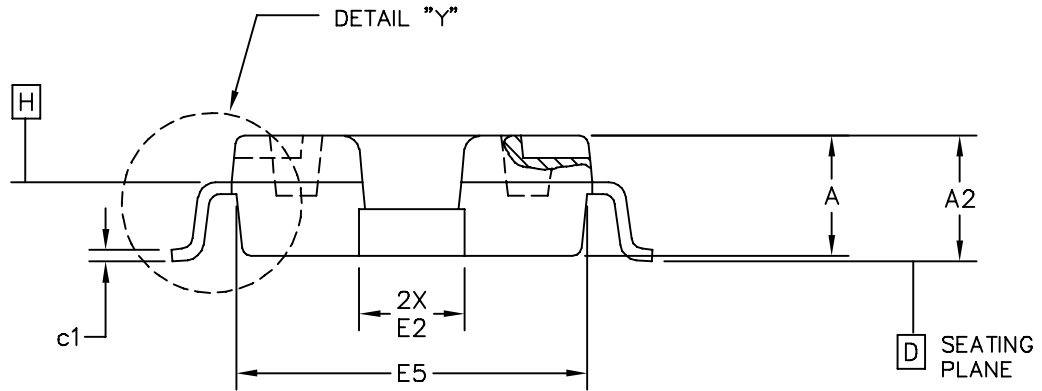
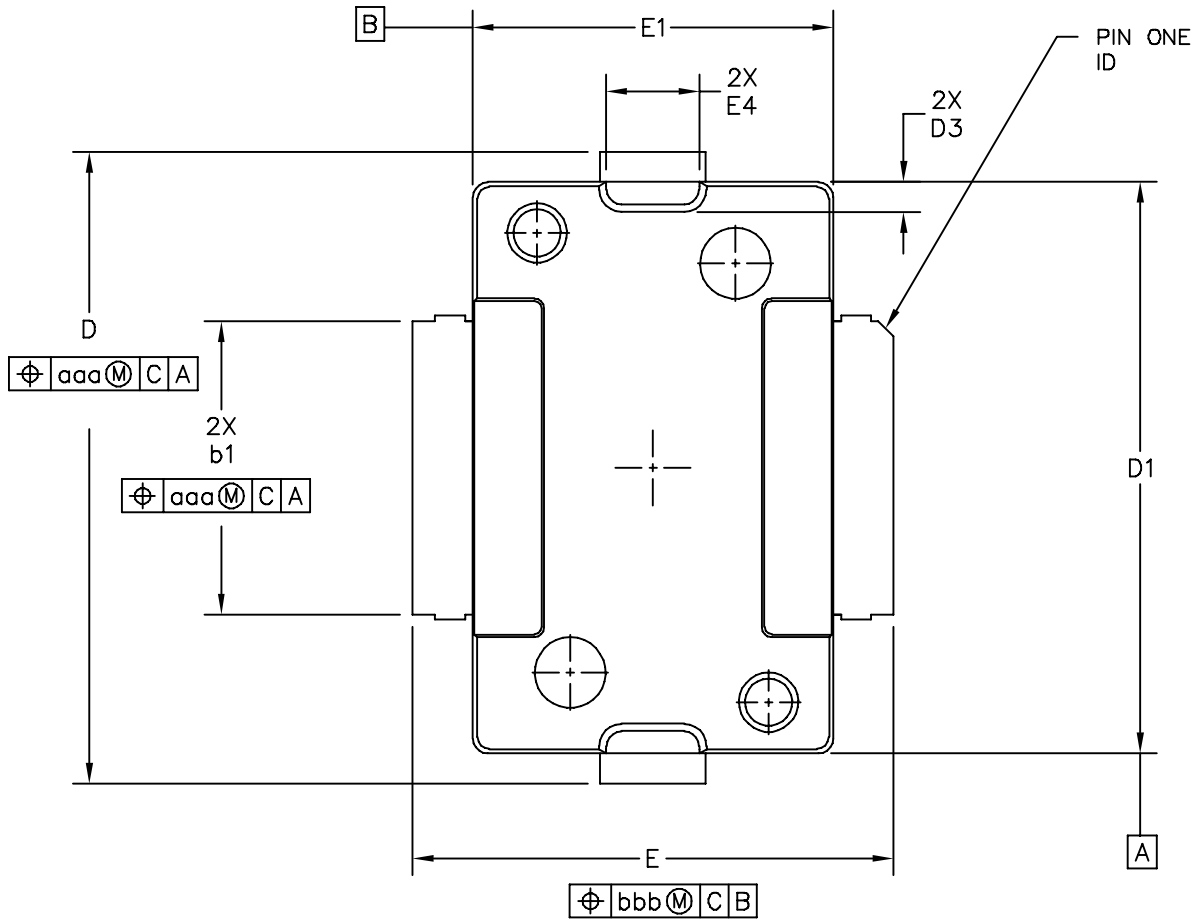

© FREESCALE SEMICONDUCTOR, INC. ALL RIGHTS RESERVED.	MECHANICAL OUTLINE	PRINT VERSION NOT TO SCALE	
TITLE: TO-270 GULL WING	DOCUMENT NO: 98ASA99301D	REV: C	
	CASE NUMBER: 1265A-03	02 JUL 2007	
	STANDARD: JEDEC TO-270 BA		

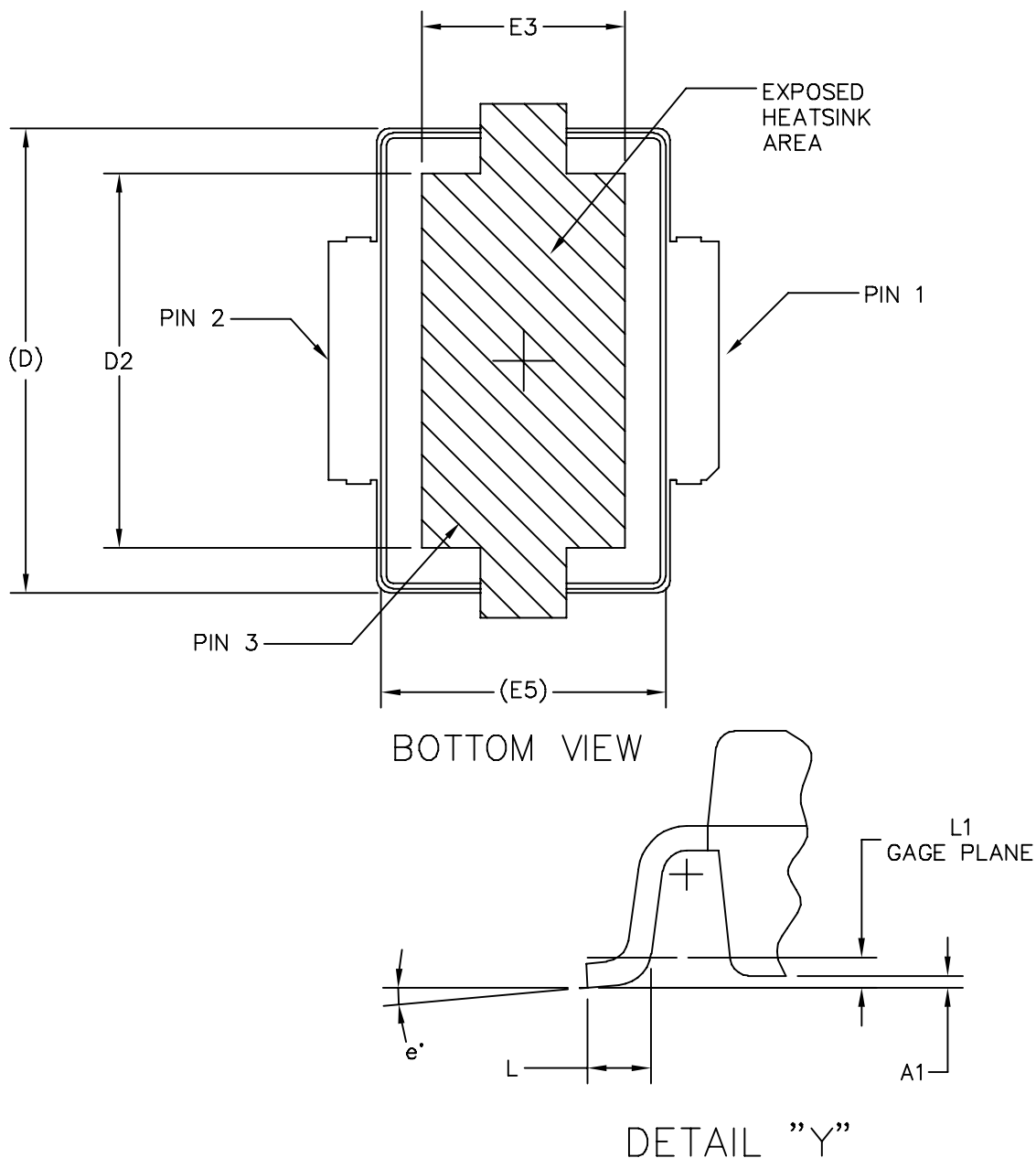

© FREESCALE SEMICONDUCTOR, INC. ALL RIGHTS RESERVED.	MECHANICAL OUTLINE	PRINT VERSION NOT TO SCALE	
TITLE: <div style="text-align: center; padding: 10px;"> TO-270 GULL WING </div>	DOCUMENT NO: 98ASA99301D	REV: C	
	CASE NUMBER: 1265A-03	02 JUL 2007	
	STANDARD: JEDEC TO-270 BA		

NOTES:

1. CONTROLLING DIMENSION: INCH
2. INTERPRET DIMENSIONS AND TOLERANCES PER ASME Y14.5M-1994.
3. DATUM PLANE -H- IS LOCATED AT TOP OF LEAD AND IS COINCIDENT WITH THE LEAD WHERE THE LEAD EXITS THE PLASTIC BODY AT THE TOP OF THE PARTING LINE.
4. DIMENSIONS "D1" AND "E1" DO NOT INCLUDE MOLD PROTRUSION. ALLOWABLE PROTRUSION IS .006 PER SIDE. DIMENSIONS "D1 AND "E1" DO INCLUDE MOLD MISMATCH AND ARE DETERMINED AT DATUM PLANE -H-.
5. DIMENSION b1 DOES NOT INCLUDE DAMBAR PROTRUSION. ALLOWABLE DAMBAR PROTRUSION SHALL BE .005 TOTAL IN EXCESS OF THE b1 DIMENSION AT MAXIMUM MATERIAL CONDITION.
6. DATUMS -A- AND -B- TO BE DETERMINED AT DATUM PLANE -H-.
7. DIMENSIONS "D" AND "E2" DO NOT INCLUDE MOLD PROTRUSION. ALLOWABLE PROTRUSION IS .003 PER SIDE. DIMENSIONS "D AND "E2" DO INCLUDE MOLD MISMATCH AND ARE DETERMINED AT DATUM PLANE -D-.

STYLE 1:

- PIN 1 - DRAIN
- PIN 2 - GATE
- PIN 3 - SOURCE

DIM	INCH		MILLIMETER		DIM	INCH		MILLIMETER	
	MIN	MAX	MIN	MAX		MIN	MAX	MIN	MAX
A	.078	.082	1.98	2.08	L	.018	.024	0.46	0.61
A1	.001	.004	0.02	0.10	L1	.01 BSC		0.25 BSC	
A2	.077	.088	1.96	2.24	b1	.193	.199	4.90	5.06
D	.416	.424	10.57	10.77	c1	.007	.011	0.18	0.28
D1	.378	.382	9.60	9.70	e	2*	8*	2*	8*
D2	.290	-	7.37	-	aaa	.004		0.10	
D3	.016	.024	0.41	0.61					
E	.316	.324	8.03	8.23					
E1	.238	.242	6.04	6.15					
E2	.066	.074	1.68	1.88					
E3	.150	-	3.81	-					
E4	.058	.066	1.47	1.68					
E5	.231	.235	5.87	5.97					
© FREESCALE SEMICONDUCTOR, INC. ALL RIGHTS RESERVED.			MECHANICAL OUTLINE			PRINT VERSION NOT TO SCALE			
TITLE: TO-270 GULL WING					DOCUMENT NO: 98ASA99301D			REV: C	
					CASE NUMBER: 1265A-03			02 JUL 2007	
					STANDARD: JEDEC TO-270 BA				

Refer to the following documents to aid your design process.

Application Notes

- AN1907: Solder Reflow Attach Method for High Power RF Devices in Plastic Packages
- AN1949: Mounting Method for the MHVIC910HR2 (PFP-16) and Similar Surface Mount Packages
- AN1955: Thermal Measurement Methodology of RF Power Amplifiers
- AN3789: Clamping of High Power RF Transistors and RFICs in Over-Molded Plastic Packages

Engineering Bulletins

- EB212: Using Data Sheet Impedances for RF LDMOS Devices

Software

- Electromigration MTTF Calculator
- RF High Power Model

For Software and Tools, do a Part Number search at <http://www.freescale.com>, and select the “Part Number” link. Go to the Software & Tools tab on the part’s Product Summary page to download the respective tool.

REVISION HISTORY

The following table summarizes revisions to this document.

Revision	Date	Description
4	Dec. 2008	<ul style="list-style-type: none"> • Changed Storage Temperature Range in Max Ratings table from -65 to +175 to -65 to +150 for standardization across products, p. 1 • Removed Total Device Dissipation from Max Ratings table as data was redundant (information already provided in Thermal Characteristics table), p. 1 • Added Case Operating Temperature limit to the Maximum Ratings table and set limit to 150°C, p. 1 • Operating Junction Temperature increased from 200°C to 225°C in Maximum Ratings table, related “Continuous use at maximum temperature will affect MTTF” footnote added and changed 200°C to 225°C in Capable Plastic Package bullet, p. 1 • Corrected V_{DS} to V_{DD} in the RF test condition voltage callout for $V_{GS(Q)}$ and added “Measured in Functional Test”, On Characteristics table, p. 2 • Corrected C_{iss} test condition to indicate AC stimulus on the V_{GS} connection versus the V_{DS} connection, Dynamic Characteristics table, p. 2 • Updated Part Numbers in Tables 6, 7, Component Designations and Values, to RoHS compliant part numbers, p. 3, 9 • Removed lower voltage tests from Fig. 10, Power Gain versus Output Power, due to fixed tuned fixture limitations, p. 6 • Replaced Fig. 12, MTTF versus Junction Temperature with updated graph. Removed Amps² and listed operating characteristics and location of MTTF calculator for device, p. 7 • Replaced Case Outline 1265-08 with 1265-09, Issue K, p. 1, 13-15. Corrected cross hatch pattern in bottom view and changed its dimensions (D2 and E3) to minimum value on source contact (D2 changed from Min-Max .290-.320 to .290 Min; E3 changed from Min-Max .150-.180 to .150 Min). Added JEDEC Standard Package Number. • Replaced Case Outline 1265A-02 with 1265A-03, Issue C, p. 1, 16-18. Corrected cross hatch pattern and its dimensions (D2 and E2) on source contact (D2 changed from Min-Max .290-.320 to .290 Min; E3 changed from Min-Max .150-.180 to .150 Min). Added pin numbers. Corrected mm dimension L for gull-wing foot from 4.90-5.06 Min-Max to 0.46-0.61 Min-Max. Added JEDEC Standard Package Number. • Added Product Documentation and Revision History, p. 19
5	June 2009	<ul style="list-style-type: none"> • Modified data sheet to reflect MSL rating change from 1 to 3 as a result of the standardization of packing process as described in Product and Process Change Notification number, PCN13516, p. 2 • Added AN3789, Clamping of High Power RF Transistors and RFICs in Over-Molded Plastic Packages to Product Documentation, Application Notes, p. 19 • Added Electromigration MTTF Calculator and RF High Power Model availability to Product Software, p. 19